

HEATH COMPANY
BENTON HARBOR, MICHIGAN

PRICE \$2.00

HEATHKIT® ASSEMBLY MANUAL

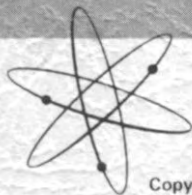

Copyright © 1971
Heath Company
All rights reserved

STEREO-4

DECODER MODEL AD-2002

1-595-1382

PARTS PICTORIAL

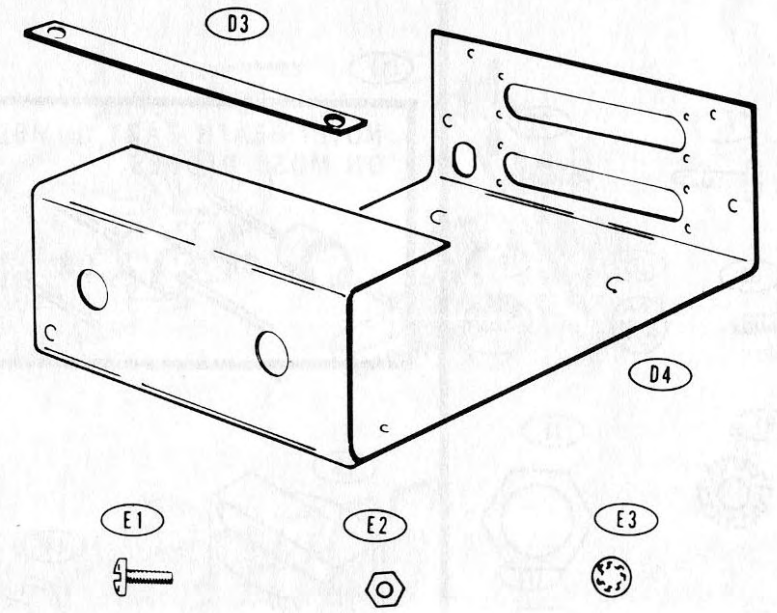
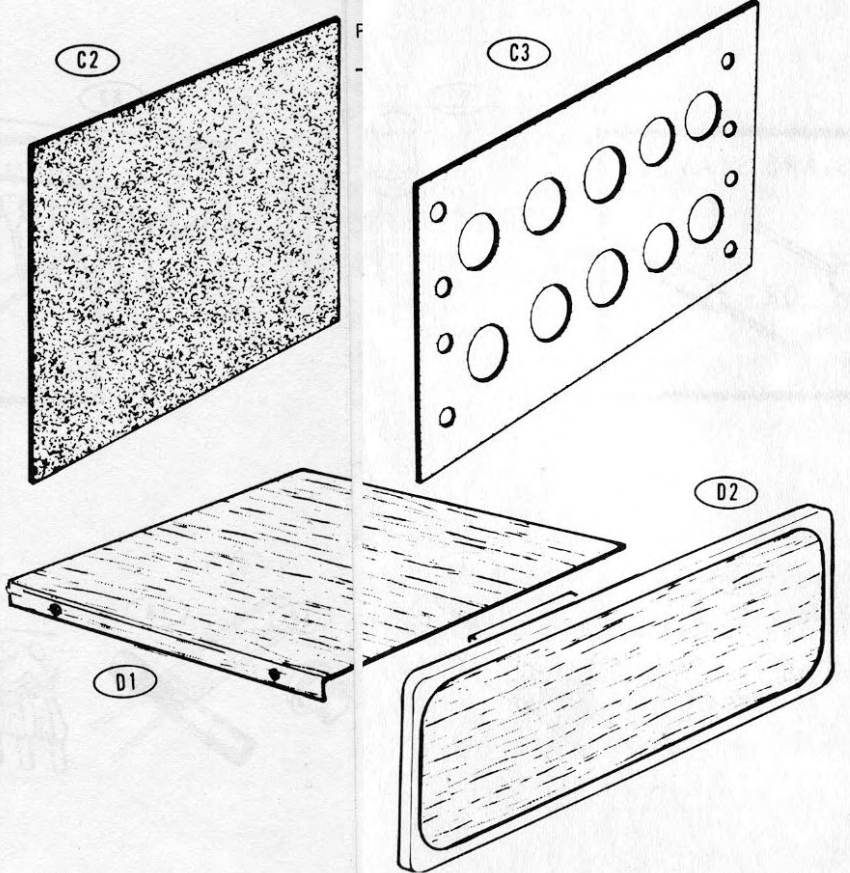
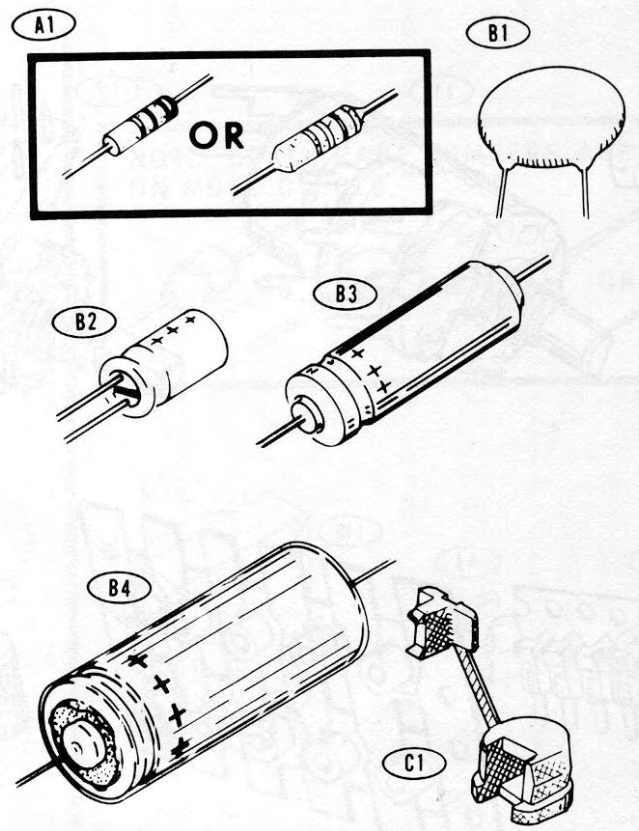

PARTS PICTORIAL (Cont'd.)

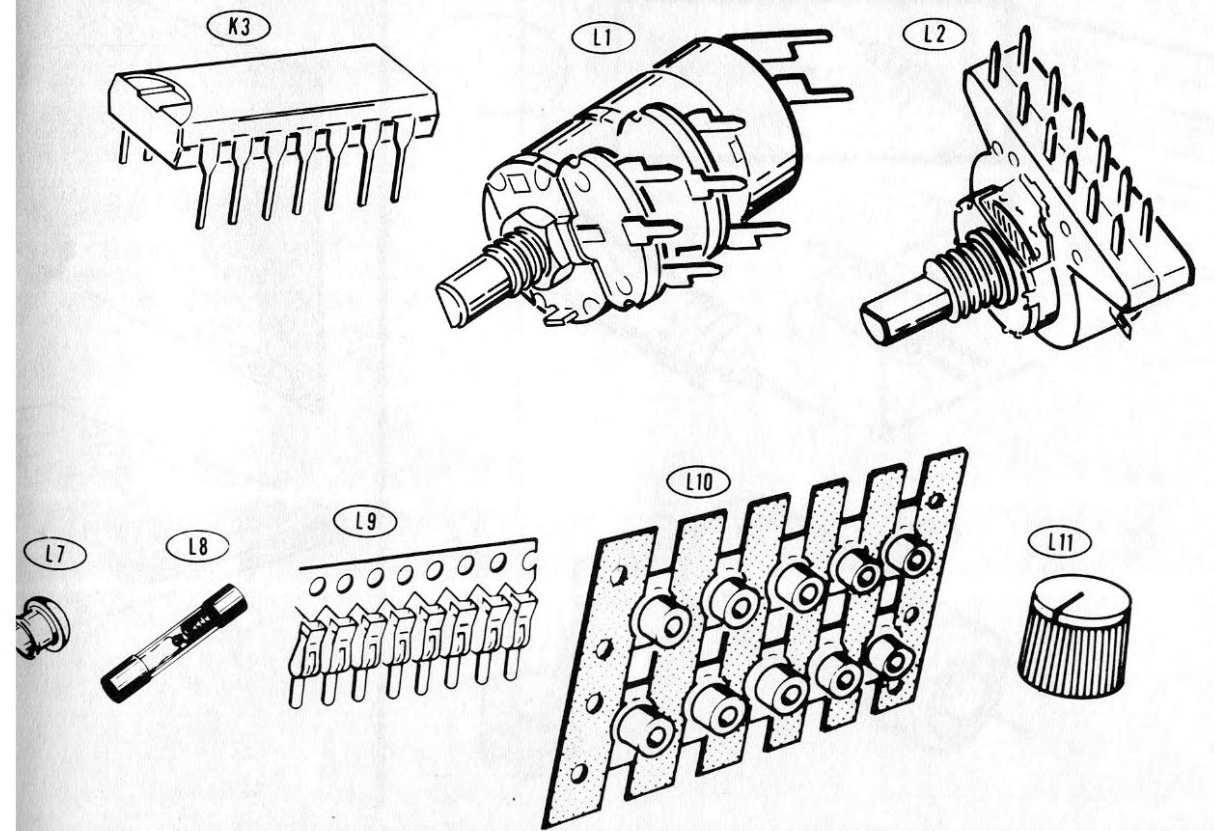
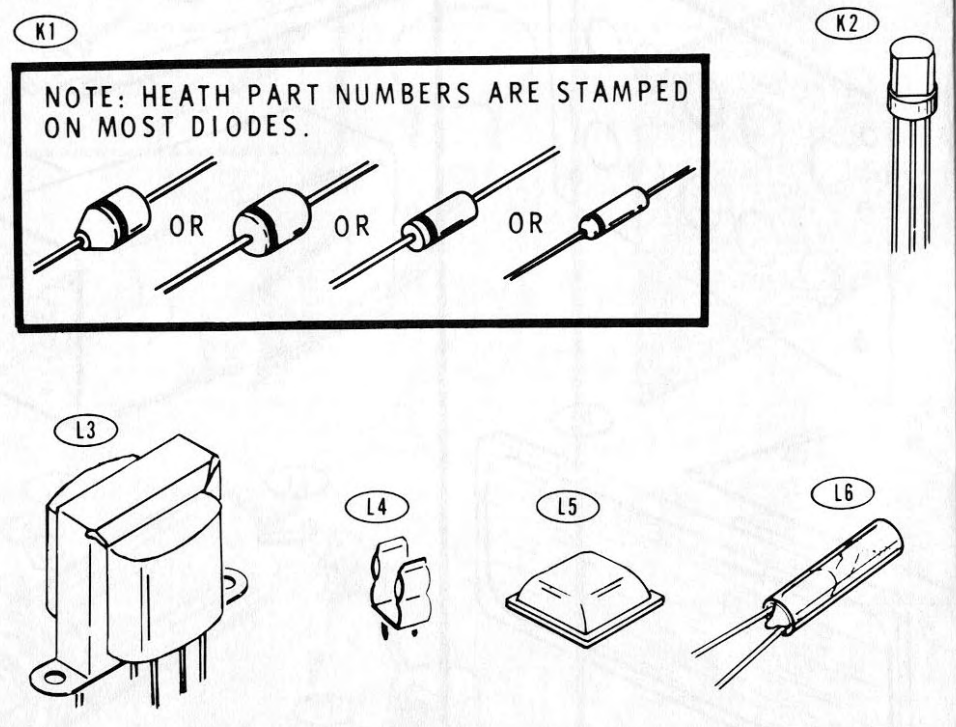
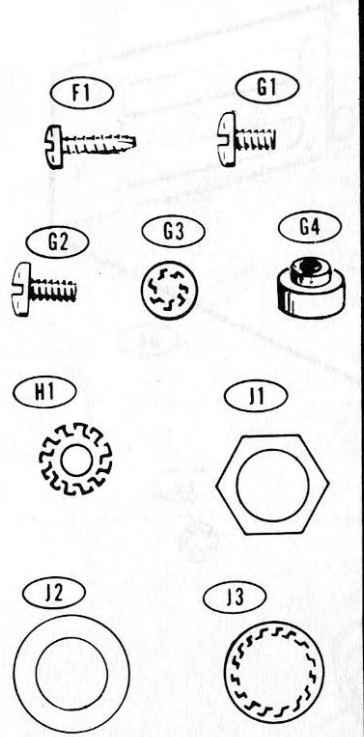

Assembly and Operation of the



STEREO-4 DECODER

MODEL AD-2002



TABLE OF CONTENTS

INTRODUCTION	2
PRICE LIST	3
STEP-BY-STEP ASSEMBLY	
Circuit Board Assembly	6
Bottom Panel Assembly and Wiring	15
INITIAL TEST	21
FINAL ASSEMBLY	23
INSTALLATION	23
OPERATION	27
IN CASE OF DIFFICULTY	28
Troubleshooting Chart	29
FACTORY REPAIR SERVICE	31
SPECIFICATIONS	32
CIRCUIT DESCRIPTION	33
X-RAY VIEW	34
SCHMATIC. . . (fold-out from page)	35
VOLTAGE CHART	36

HEATH COMPANY
Benton Harbor, Michigan 49022

INTRODUCTION

The Heathkit Model AD-2002 Stereo-4 Decoder is a unique part of a four-channel matrix music system. With the Decoder and two stereo systems (amplifiers and speakers), four-channel sound can be produced for your listening pleasure. The program material can come from either regular stereo sources or from special four-channel stereo records, tapes, and FM broadcasts.

Rather than obsolete your current stereo record or tape collection or stereo FM tuner, the decoder can enhance your listening pleasure of these two-channel stereo sources by reproducing in the rear channels phase information which is not usually audible when reproduced in two-channel stereo only. This phase information occurs unpredictably and varies from record to record, but most records contain some degree of these additional signals.

To achieve Stereo-4 music reproduction with the Decoder, a stereo amplifier and a pair of speakers must be added to your present stereo system.

The Decoder is easily connected between the preamplifier and four amplifiers; a receiver's tape monitor facilities can be used. An extra set of tape input and output jacks is provided on the Decoder.

All components are mounted on a single circuit board to provide easy assembly. The simulated wood-grain cabinet makes an attractive addition to any stereo system and the Decoder will provide much added enjoyment to your stereo listening.

Refer to the "Kit Builders Guide" for complete information on unpacking, parts identification, tools, wiring, soldering, and step-by-step assembly procedures.

PARTS LIST

Check each part against the following list. The key numbers correspond to the numbers on the Parts Pictorial (fold-out from Pages 3 and 4).

To order replacement parts, use the Parts Order Form furnished with this kit. If the Parts Order Form is not available, refer to the "Replacement Parts" section in the "Kit Builders Guide."

KEY PART No.	PARTS No.	DESCRIPTION	PRICE Each
-----------------	--------------	-------------	---------------

RESISTORS, 1/2-Watt

A1	4-74	1	680 Ω (blue-gray-brown)	.10
A1	4-47	1	1200 Ω (brown-red-red)	.10
A1	4-63	1	2700 Ω (red-violet-red)	.10
A1	4-34	4	100 k Ω (brown-black-yellow)	.10
A1	4-33	2	470 k Ω (yellow-violet-yellow)	.10

CAPACITORS

Disc

B1	21-42	1	.01 μ F	.15
----	-------	---	-------------	-----

Electrolytic

B2	25-257	6	10 μ F	.25
B3	25-146	1	100 μ F	.45
B4	25-121	1	500 μ F	1.30

KEY PART No.	PARTS No.	DESCRIPTION	PRICE Each
-----------------	--------------	-------------	---------------

INSULATORS

C1	75-30	1	Line cord strain relief	.10
C2	75-90	1	Insulator sheet	.10
C3	75-169	1	Phono socket insulator	.10

CABINET PARTS

D1	203-861	1	Cabinet top	1.50
D2	203-860	2	Cabinet side	.80
D3	212-39	1	Cabinet side brace	.10
D4	200-624-1	1	Cabinet bottom	2.90

HARDWARE

#3 Hardware

E1	250-49	8	3-48 x 1/4" screw	.05
E2	252-1	8	3-48 nut	.05
E3	254-7	8	#3 lockwasher	.05



KEY PART		PARTS	DESCRIPTION	PRICE	KEY PART		PARTS	DESCRIPTION	PRICE
No.	No.	Per Kit		Each	No.	No.	Per Kit		Each
#4 Hardware					LINE CORD-WIRE				
F1	250-593	8	#4 x 3/8" sheet metal screw	.05	89-37		1	Line cord	.65
					344-90		1	Black stranded hookup wire	.05/ft
#6 Hardware									
G1	250-138	4	6-32 x 3/16" screw	.05	344-92		1	Red stranded hookup wire	.05/ft
G2	250-56	2	6-32 x 1/4" screw	.05	134-36		6	Audio cable	.75
G3	254-1	3	#6 lockwasher	.05					
G4	255-163	3	6-32 tapped spacer	.10					
#8 Hardware					DIODES-TRANSISTOR-INTEGRATED CIRCUIT				
H1	254-21	3	#8 lockwasher	.05	K1	56-45	1	VR-20 zener diode	1.00
Control Hardware					K1	57-65	2	1N4002 silicon diode	.20
J1	252-7	2	Control nut	.05	K2	417-94	1	2N3416 transistor	1.00
J2	253-10	2	Control flat washer	.05	K3	442-34	1	Decoder IC	5.00
J3	254-5	2	Control lockwasher	.05					

KEY PART		PARTS Per Kit	DESCRIPTION	PRICE Each	KEY PART		PARTS Per Kit	DESCRIPTION	PRICE Each
No.	No.				No.	No.			
MISCELLANEOUS					Miscellaneous (cont'd.)				
L1	14-10	1	Dual 250 kΩ control with switch	2.90	L10	434-218	1	Phono socket assembly	.65
L2	63-636	1	3-position rotary switch	1.95	L11	462-351	2	Knob	.55
L3	54-292	1	Power transformer	1.60		449-113	1	Demonstration record	.70
	85-1104-1	1	Circuit board	1.55		490-5	1	Nut starter	.10
L4	260-65	2	Fuse clip	.10		391-34	1	Blue and white identi- fication label	
L5	261-29	4	Plastic feet	.05		597-260	1	Parts Order Form	
L6	412-51	1	Pilot lamp	.70		597-308	1	Kit Builders Guide Manual (See front cover for part number.) Solder	2.00
L7	413-31	1	Pilot lamp lens	.10				(Additional 3' rolls of solder, #331-6, can be ordered for 15 cents each.)	
L8	421-27	1	1/16-ampere slow-blow fuse	.45					
L9	432-144	14	IC connector	.01					

The above prices apply only on purchases from the Heath Company where shipment is to a U.S.A. destination. Add 10% (minimum 25 cents) to the price when ordering from a Heathkit Electronic Center to cover local sales tax, postage and handling. Outside the U.S.A. parts and service are available from your local Heathkit source and will reflect additional transportation, taxes, duties and rates of exchange.

STEP-BY-STEP ASSEMBLY

Before starting the assembly of this kit, read the "Kit Builders Guide" for complete information on wiring, soldering, and step-by-step assembly procedures.

CIRCUIT BOARD ASSEMBLY

Components will be installed on the circuit board by following steps on

Pictorials 1-1 through 1-7.

- () Position the circuit board (#85-1104-1) with the lettered (component) side up as shown and complete the circuit board assembly steps, beginning with Pictorial 1-1.

START



() 100 k Ω (brown-black-yellow).

() 100 k Ω (brown-black-yellow).

() 2700 Ω (red-violet-red).

() 1200 Ω (brown-red-red).

() 100 k Ω (brown-black-yellow).

() 470 k Ω (yellow-violet-yellow).

() 470 k Ω (yellow-violet-yellow).

() 100 k Ω (brown-black-yellow).

() 680 Ω (blue-gray-brown).

FOR GOOD SOLDERED
CONNECTIONS, YOU MUST
KEEP THE SOLDERING
IRON TIP CLEAN...

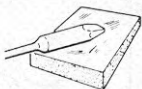

WIPE IT OFTEN WITH A
DAMP SPONGE OR CLOTH.

() Solder the leads to the foil and cut off the excess lead lengths.

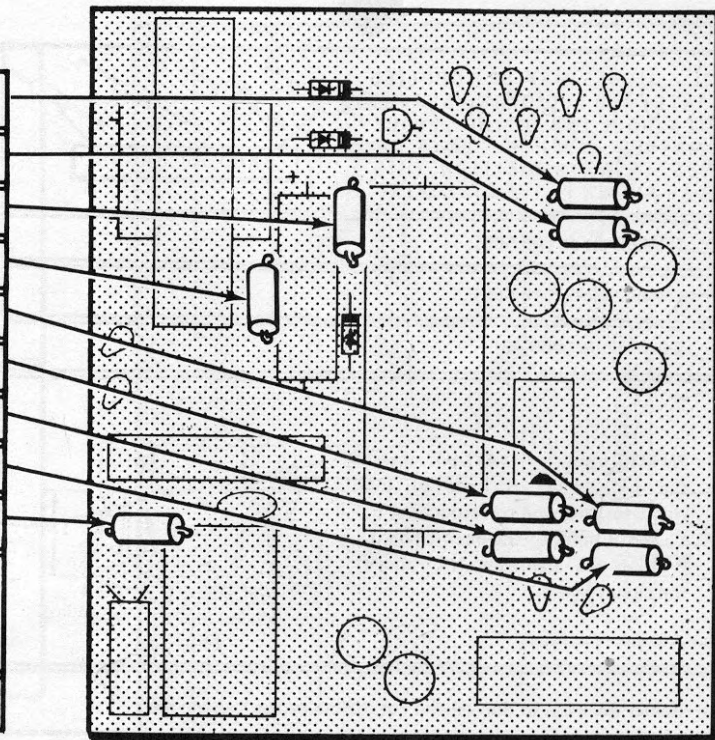

PICTORIAL 1-1

START



NOTE: DIODES MAY BE SUPPLIED IN ANY OF THE FOLLOWING SHAPES. THE CATHODE END OF THE DIODE IS MARKED WITH A BAND OR BANDS. ALWAYS POSITION THIS END AS SHOWN IN THE PICTORIAL.

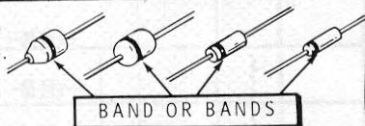

() 1N4002 diode (#57-65).

() 1N4002 diode (#57-65).

() Zener diode (#56-45).

() 2N3416 transistor (#417-94). Insert the E, C, and B leads of the transistor into the corresponding E, C, and B holes of the circuit board. Position the transistor 1/4" above the circuit board.

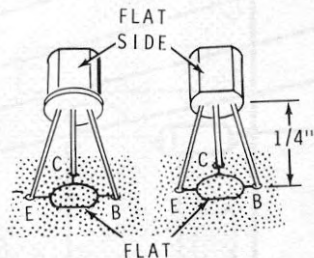

() Solder the leads to the foil and cut off the excess lead lengths.

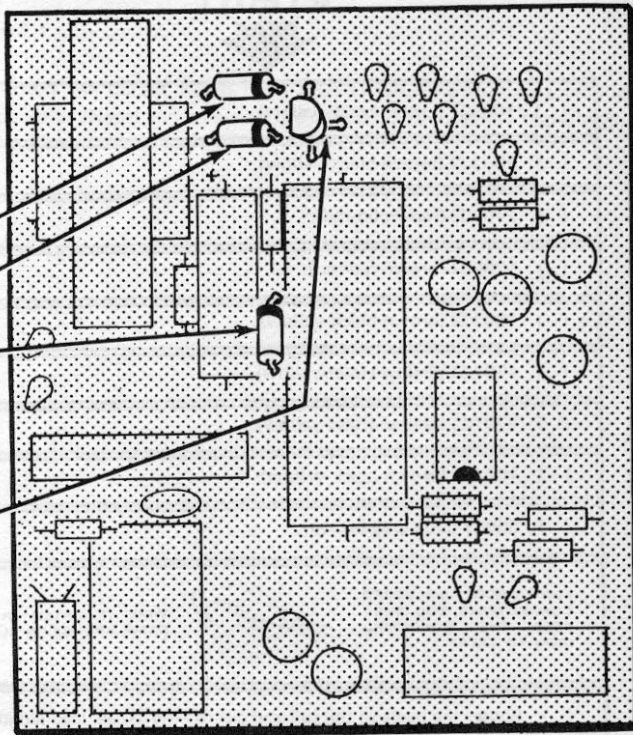

PICTORIAL 1-2

START



NOTE: In the following step you will install strips of IC connectors. Once the connectors are inserted into the holes of the circuit board, turn the circuit board over and solder the pins to the foil. Be sure the strips are perpendicular to the circuit board before soldering. If a solder bridge occurs, clean the soldering iron tip and hold it between the two pins that are bridged until the excess solder flows down the tip of the soldering iron.

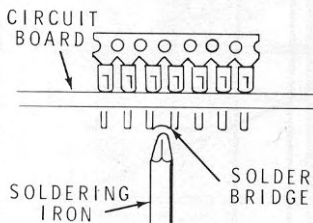

() Two strips of seven IC connectors.

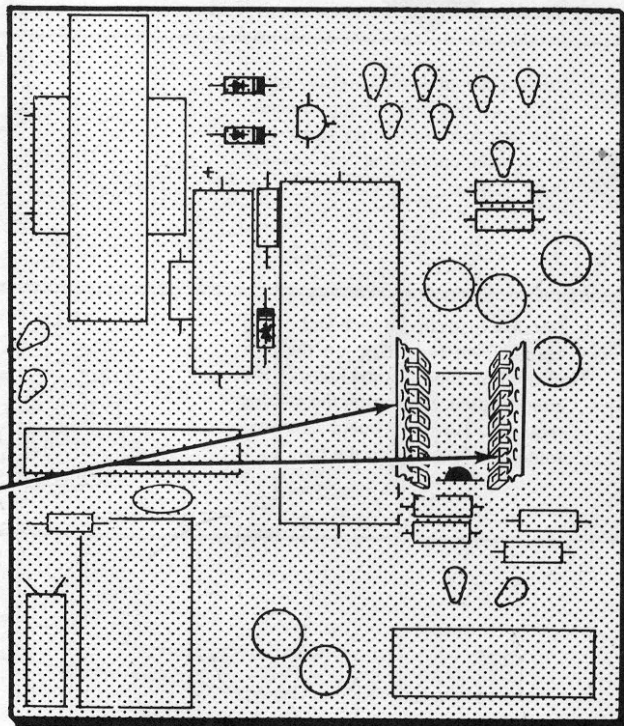
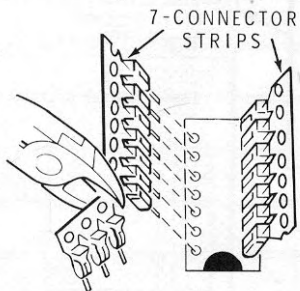

PICTORIAL 1-3

START



- () Using a pair of pliers, carefully bend the connecting links of the IC strips back and forth until they break off. Bend each connecting link inward first.

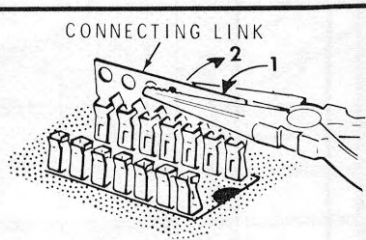

- () Install a fuse clip on each end of the 1/16-ampere fuse. Position the pins of the fuse clips into the holes of the circuit board. Reposition the clips as required. Turn the board over and solder the fuse clips to the foil.

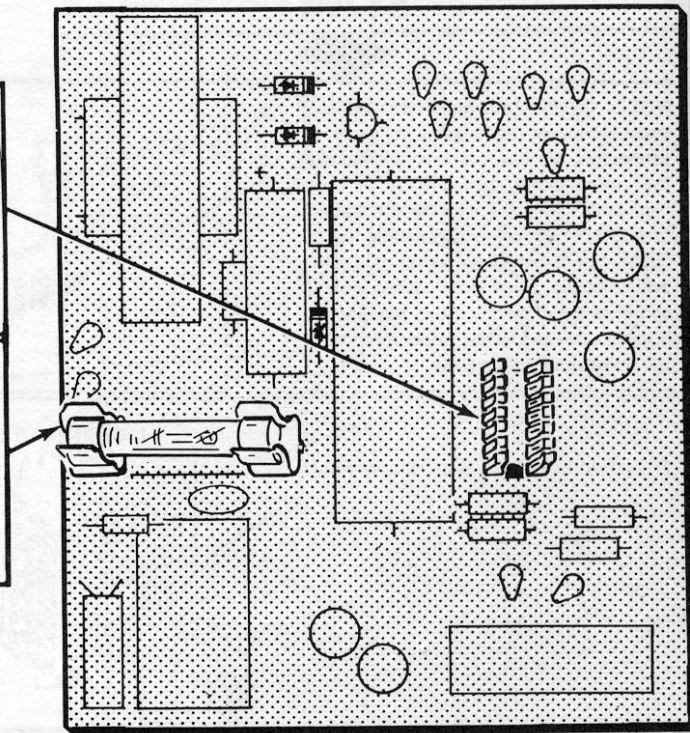
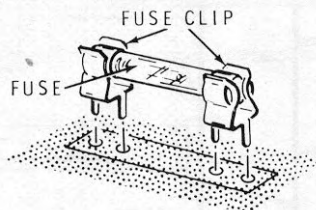

PICTORIAL 1-4

START



- () Power transformer (#54-292). Position the leads into the proper circuit board holes and push the transformer tight against the circuit board. Align the transformer mounting holes with the circuit board mounting holes. Solder the leads to the foil and cut off the excess lead lengths.

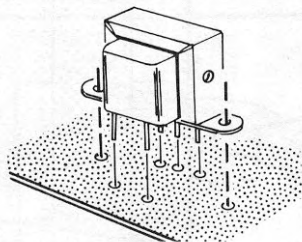

- () 3-position rotary switch (#63-636). Position the pins of the switch into the circuit board holes and push the switch tight against the circuit board. Solder the pins to the foil making sure the switch is perpendicular to the circuit board. Then cut off the excess pin lengths.

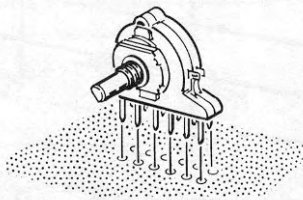

- () Dual 250 k Ω control with switch (#14-10). Position the pins of the control into the circuit board holes and push the control tight against the circuit board. Solder the pins to foil.

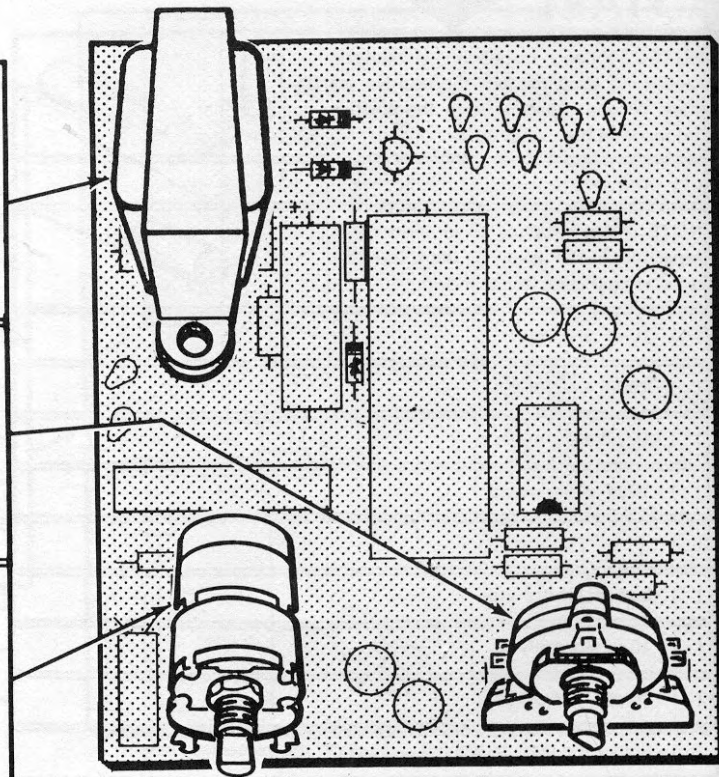

PICTORIAL 1-6

START



- () Decoder IC (#442-34). Position the notch or dot end of the IC over the dot screened on the circuit board. Be sure all of the IC pins are straight; then insert the IC leads into the IC connectors. DO NOT solder the IC to the connectors. Be sure each pin of the IC is in its connector.

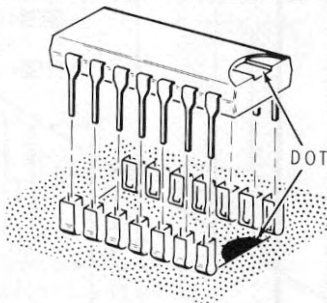

NOTE: Should it ever become necessary to remove the IC from its connectors, slide a screwdriver blade under the IC; then gently lift the IC out of the connectors.

- () Pilot lamp. Insert the leads of the pilot lamp into their holes in the circuit board. Be sure the lamp housing is positioned over its outline on the circuit board. Solder both leads to the foil and cut off the excess lead lengths.

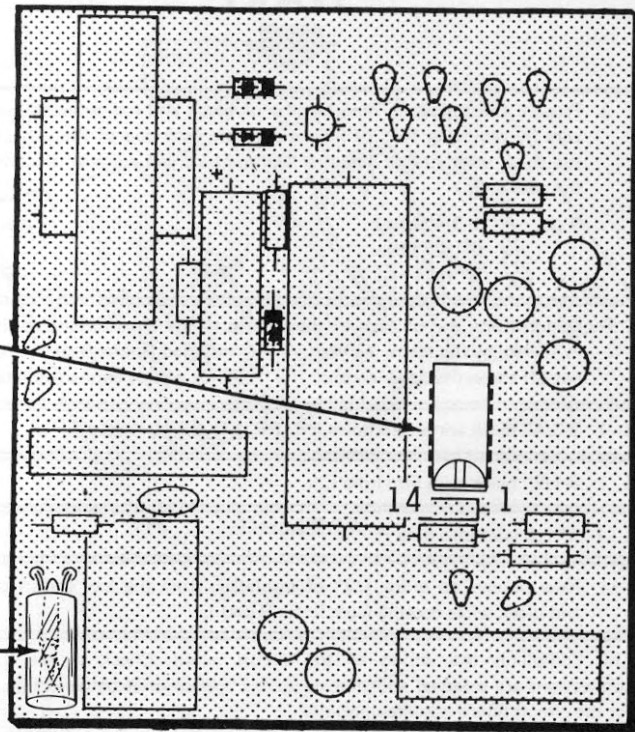

PICTORIAL 1-7

START

- () Prepare the following nine lengths of black and red stranded hookup wire by removing 1/4" of insulation from each end of the wire. Twist the small wire strands together and melt a small amount of solder on the wire ends.

7	2-3/4" black
1	6-1/2" black
1	6" red

Connect one end of each of these wires to the circuit board as directed in the following steps. As each wire is installed, solder it to the foil and cut off the excess lead lengths. The free ends will be connected later.

- () 2-3/4" black wires into holes RR, RF, LR, LF, J, K, and G.
- () 6-1/2" black wire into hole L.
- () 6" red wire into hole R.
- () Now remove an extra 1/2" of insulation from the free end of the red and black wires coming from holes R and L.

This completes the wiring of the circuit board. Check to see that all connections are soldered and that no solder bridges exist between foils. Then set the circuit board aside temporarily.

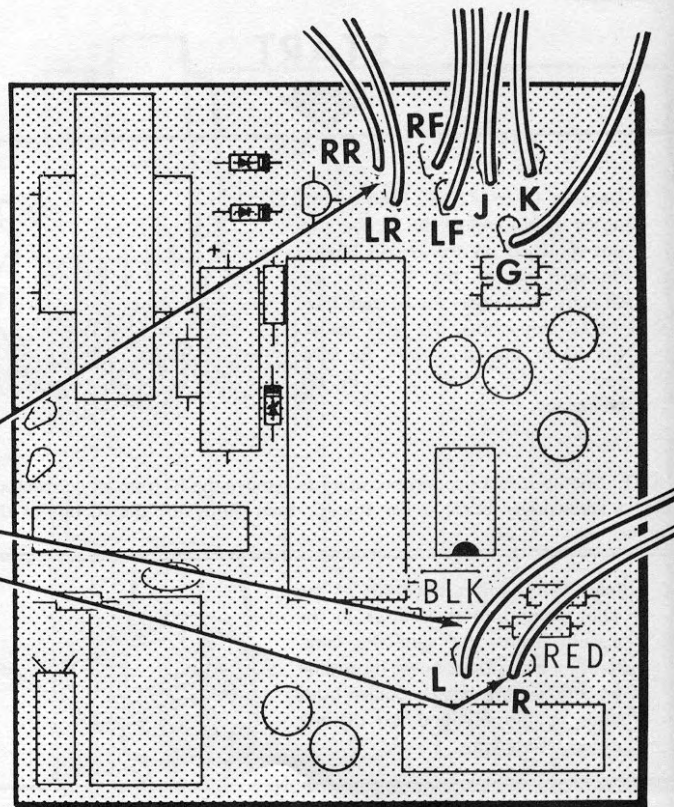
**FINISH**

PICTORIAL 1-8

3/4 1/2 1/4 0

1"

2"

3"

4"

5"

6"



BOTTOM PANEL ASSEMBLY AND WIRING

Refer to Detail 2-1A for the following steps.

- () Prepare the following lengths of black hookup wire by removing 1/4" of insulation from both ends of each wire. The wires are listed in the order that they will be used.

1-1/2"

1-3/4"

1-1/2"

1-1/4"

1-1/2"

- () Locate the phono socket assembly and position it as shown. Note that there are no small lugs between lugs 3 and 4 and lugs 11 and 12.

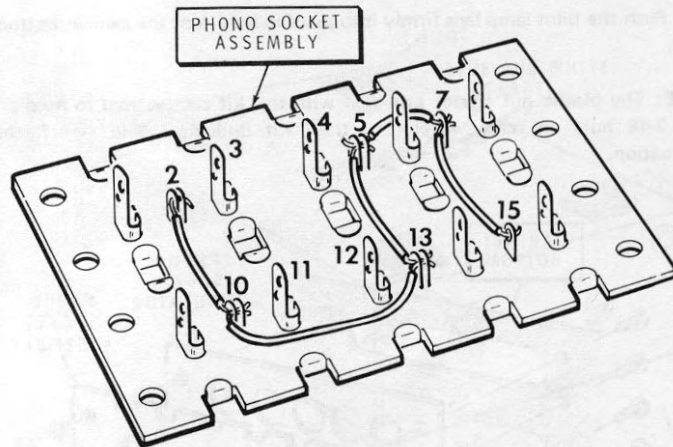

Detail 2-1A

Connect the prepared wires to the phono socket assembly as directed in the following steps. Note that there are double lugs at locations 2, 5, 10, and 13. The wire ends must be connected through both lugs, and both lugs must be soldered at these locations when soldering instructions are given in a step. Position each wire as shown.

- () 1-1/2" wire between lugs 2 (S-1) and 10 (NS).
- () 1-3/4" wire between lugs 10 (S-2) and 13 (NS).
- () 1-1/2" wire between lugs 13 (S-2) and 5 (NS).
- () 1-1/4" wire between lugs 5 (S-2) and 7 (NS).
- () 1-1/2" wire between lugs 7 (S-2) and 15 (NS).

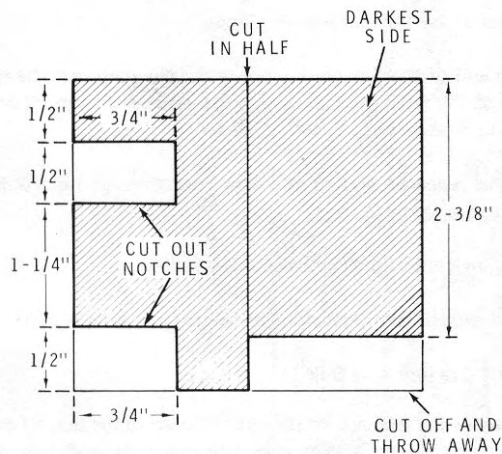

Detail 2-1D

- () Locate the insulator sheet, position it with its darkest side up, and cut it in half. Then cut the notches from one of the two pieces according to the dimensions in Detail 2-1D. Also cut the second piece according to the dimensions in the Detail.
- () Remove the paper backing from the insulator sheets and press the sheets into place in the cabinet bottom as shown in Pictorial 2-1.
- () Remove the paper backing from the four feet. Then refer to Detail 2-1E and press the four feet into place on the bottom side of the bottom panel.

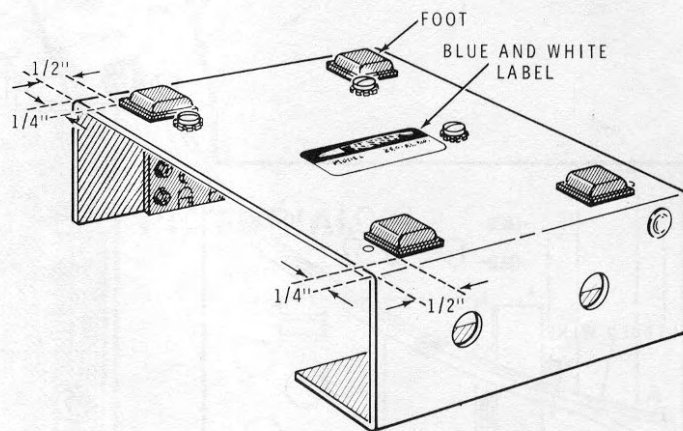

Detail 2-1E

- () Carefully peel away the backing paper from the blue and white identification label. Then press the label on the cabinet bottom. Be sure to refer to the numbers on this label in any communications you have with the Heath Company about this kit.

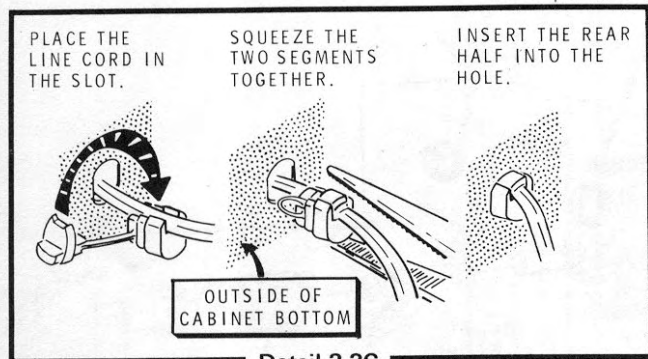

- () Refer to Detail 2-2C and install the line cord strain relief around the line cord and into hole G. Position the line cord as shown in Pictorial 2-2.

Connect the free end of the wires coming from the indicated holes in the circuit board to the indicated lugs of phono socket assembly H as follows:

- () Black wire from hole RR to lug 9 (S-1).
- () Black wire from hole RF to lug 11 (S-1).

- () Black wire from hole K to lug 12 (S-1).
- () Black wire from hole G to lug 15 (S-2).
- () Black wire from hole LR to lug 1 (S-1).
- () Black wire from hole LF to lug 3 (S-1).
- () Black wire from hole J to lug 4 (S-1).

NOTE: Where a wire passes through a connection and then goes to another point, as in the next step, it will count as two wires in the solder instructions (S-2), one entering and one leaving the connection.

- () Red wire from hole R through lug 16 (S-2) to lug 14 (S-1). Be sure the wire does not touch lug 15.
- () Black wire from hole L through lug 8 (S-2) to lug 6 (S-1). Be sure the wire does not touch lug 7.

This completes the wiring. Check to see that all connections are soldered, that no wires touch connections other than those to which they are connected, and then shake out any wire clippings or solder splashes. Then proceed to "Initial Test."

WARNING
HIGH VOLTAGE IS IN THIS AREA
WHEN LINE CORD IS PLUGGED INTO
A.C. OUTLET.

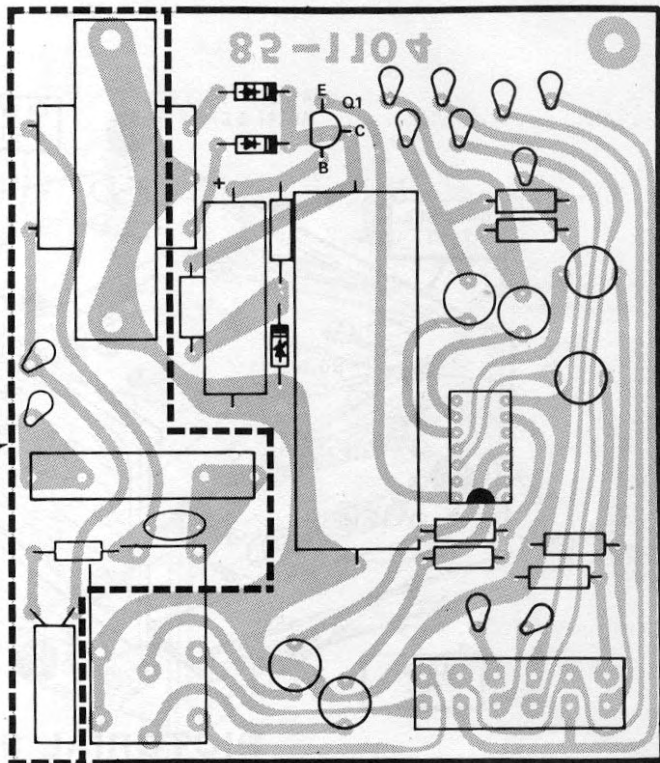
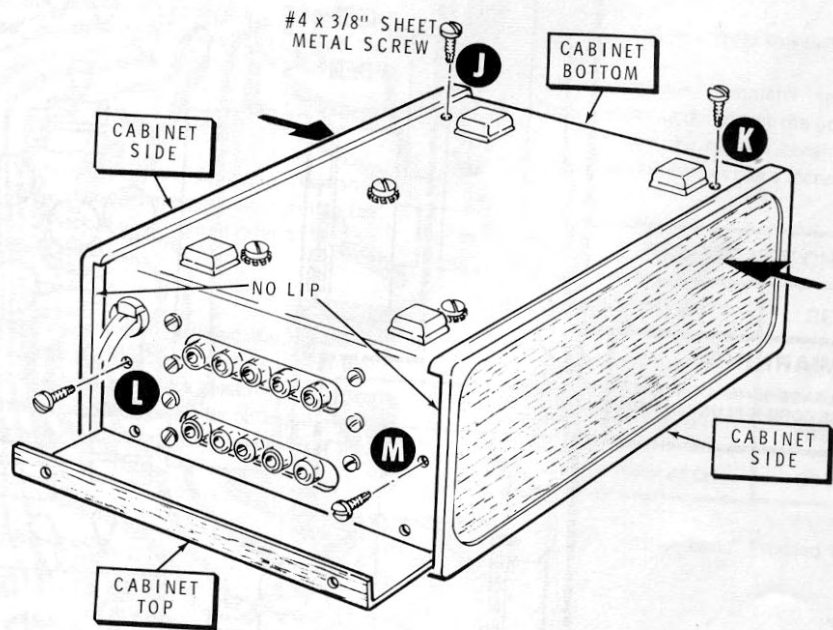
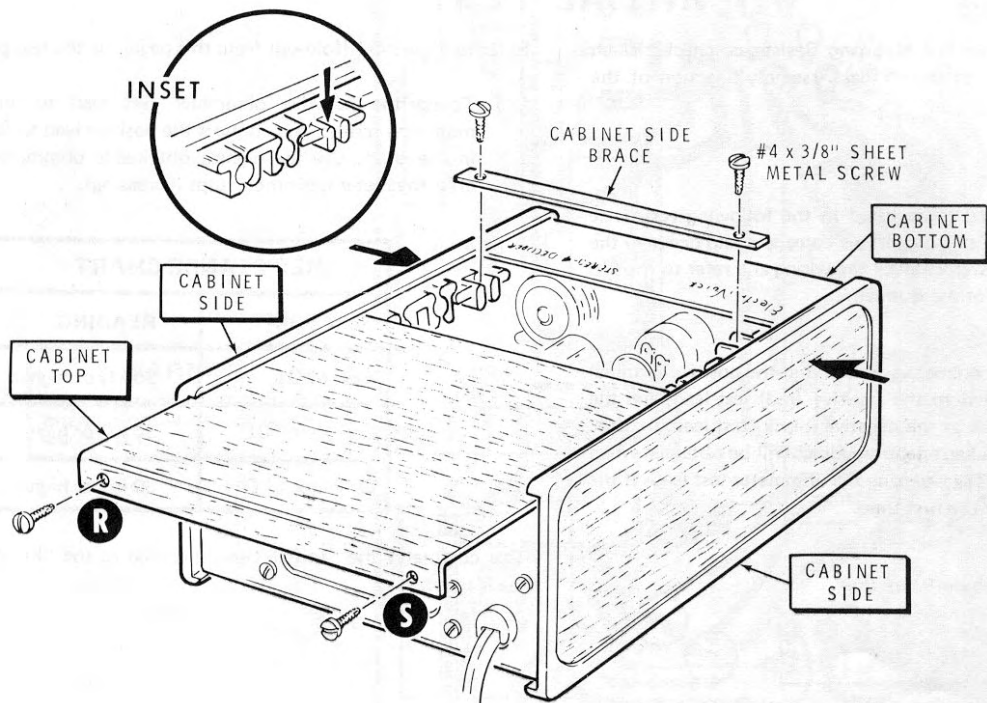

FIGURE 1-1



PICTORIAL 3-1



PICTORIAL 3-2

INITIAL TEST

If an ohmmeter is available, perform the following Resistance checks. If an ohmmeter is not available, proceed to the "Final Assembly" section of the Manual.

RESISTANCE CHECK

Your ohmmeter readings must exceed those listed in the following resistance chart before you apply power to the unit or serious damage could occur to the power supply. If your readings are lower, recheck the wiring and refer to the "In Case of Difficulty" section (Page 28) of the Manual.

NOTE: The internal wiring of most ohmmeters is such that the positive terminal of the ohmmeter battery is connected to the positive (red) test lead, and the negative battery terminal is connected to the negative (black) test lead. In some ohmmeters, this wiring is reversed and erroneous readings will be obtained when making the following measurements. Try reversing the ohmmeter test leads if the measurements do not check correctly the first time.

() Place the ohmmeter range switch on RX10,000.

Refer to Figure 1-1 (fold-out from this page) for the test point locations.

() Touch the negative ohmmeter test lead to one of the transformer mounting screws, and connect the positive lead to the test points indicated in the chart. Use the highest obtainable ohmmeter reading (the reading after the meter indication stops increasing).

RESISTANCE CHART	
TEST POINT	READING
Base of Q1.	30 k Ω or higher
Emitter of Q1.	30 k Ω or higher
Collector of Q1.	30 k Ω or higher

This completes the "Initial Test." Proceed to the "Final Assembly" section of the Manual.

FINAL ASSEMBLY

Refer to Pictorial 3-1 for the following steps.

- () Position the bottom panel upside down on a soft cloth. Fit a cabinet side onto both side edges of the cabinet bottom. Note that the cabinet sides have no lip at their rear edges.

CAUTION: Do not overtighten the screws when mounting the cabinet sides. The threads made in the plastic by these screws can be stripped out.

- () While pushing inward on the cabinet sides (see arrows on Pictorial 3-1), install #4 x 3/8" sheet metal screws into holes J and K of the bottom panel.
- () Slide the cabinet top part way into the indicated grooves of the side panel.

- () Push inward on the cabinet sides near the back of the cabinet sides and install #4 x 3/8" sheet metal screws in holes L and M of the bottom panel.

Refer to Pictorial 3-2 for the following steps.

- () Turn the unit right side up, making sure the cabinet top remains in place. While pressing the cabinet sides inward (see the arrows in Pictorial 3-2), install the cabinet side brace with #4 x 3/8" sheet metal screws. See the inset drawing for the proper screw location in the cabinet sides.
- () Slide the cabinet top all the way forward and install #4 x 3/8" sheet metal screws in holes R and S of the cabinet top.

This completes the assembly of the unit. Proceed to the "Installation" section of the Manual.

INSTALLATION

GENERAL CONSIDERATIONS

A typical two-channel (stereo) system requires a source, preamplifier, amplifier, and speaker for each channel. These functions may be in one unit, separate units, or some combination of units. In addition to the above two-channel system, this four-channel system requires the Decoder, two amplifiers (or one stereo amplifier) and two speakers. The standard units will not need modification since the Decoder is simply plugged into the system.

A two-channel system provides left and right effects when the speakers are

separated and placed in front of the listener. Connect the additional two channels of a four-channel system to two more speakers. Separate the speakers similar to the front speakers and place these speakers either behind or to the side of the listener. Position them to face the front of the room. This will produce back effects and the front and rear systems can then be balanced in the same manner as left and right channels.

Four-channel equipment requirements are less critical than those for two-channel. However, four matched amplifiers (or a four-channel amplifier) and four matched speakers will give the best results.

Speakers or amplifiers matched in pairs will give good results, but in this case favor the front system with the better equipment.

However, the input sensitivity must be adequate for the source; the Decoder does not amplify.

The more complete unit (receiver preferred to amplifier) should be used in the front system and the program source should be connected to this unit. If units are to be stacked, one on top of another, place the front system unit on top for the least confusion.

Decide which units you will use for the front system, which you will use for the rear system, and identify them in your mind or use labels on the units for later reference.

Most modern stereo receivers can be represented by the block diagram shown in Figure 2-1. Any of several inputs (tuner, phono, auxiliary) can be selected and coupled to the preamplifier by the selector switch. Notice that the tape monitor switch disconnects the preamplifier from the power amplifier. This feature allows the stereo receiver to function as two units, a program source and a power amplifier. Thus the receiver can supply the program material and an amplifier for the front system.

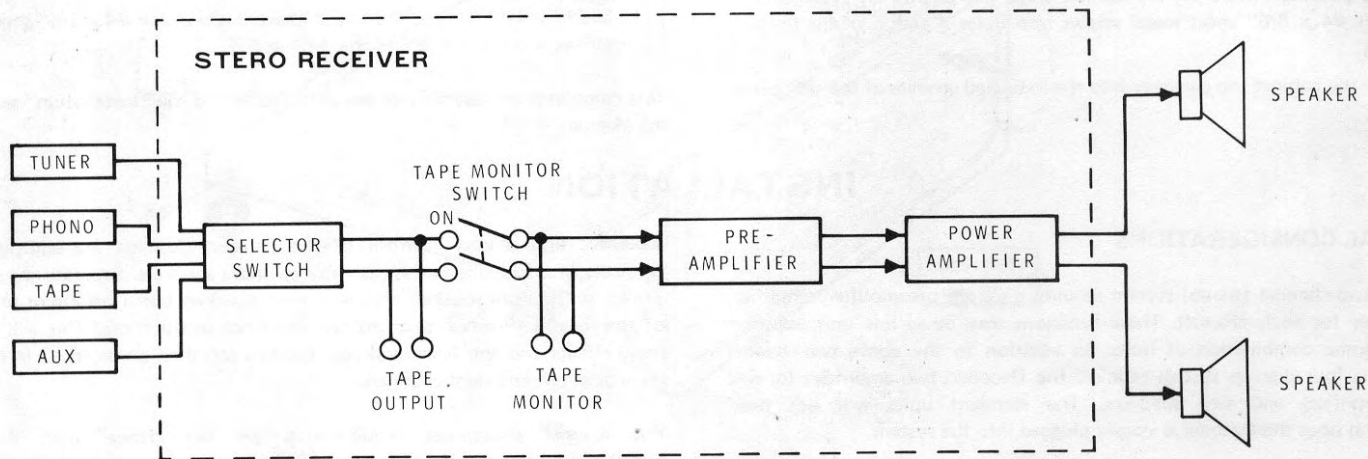

Figure 2-1

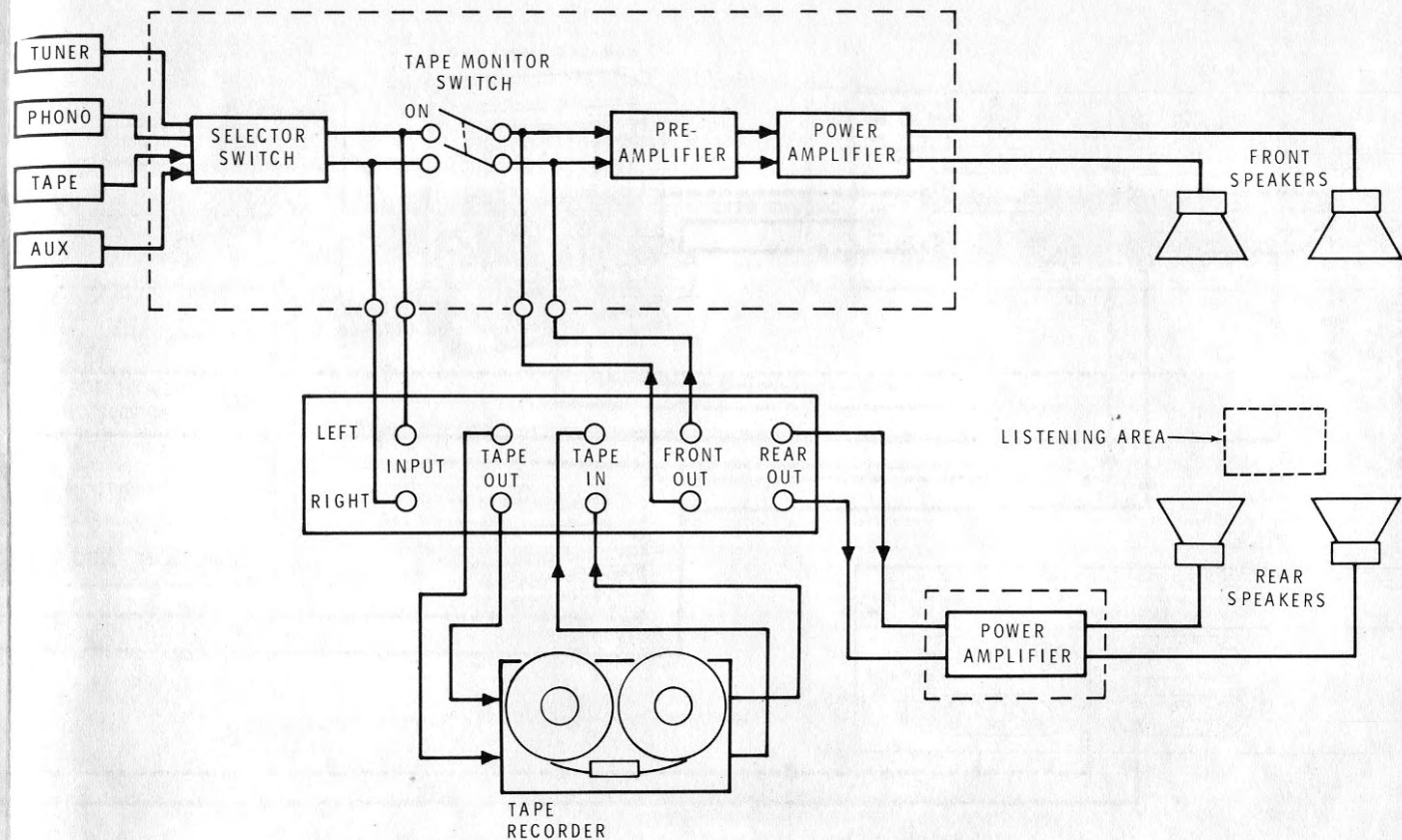

FIGURE 2-2

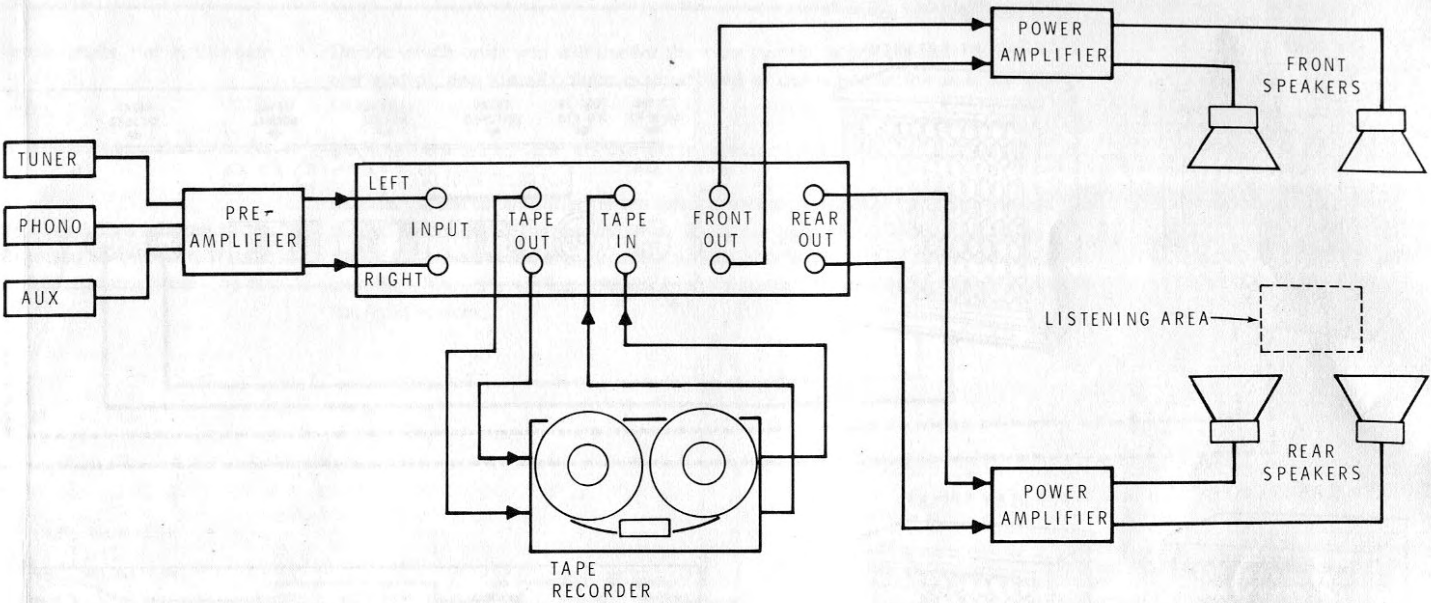

FIGURE 2-3

OPERATION

Once the Decoder and the systems are properly connected, switch the front system and rear system tape monitor switches to the tape position (or the input position that you connected to the Decoder outputs). This connects the Decoder output to all four channels. Turn each of the amplifier volume controls all the way down.

A Stereo-4 demonstration record has been included in your kit. Use this record for the initial try-out to demonstrate the capabilities of the Stereo-4 system.

The Decoder has two controls, a MASTER GAIN control that also serves as an on-off switch, and a FUNCTION switch. Turn the Decoder MASTER GAIN control 1/2 rotation clockwise and the FUNCTION switch to the SOURCE DECODE position.

Turn the units on and turn up the volume controls of the amplifiers for the desired sound level in the room. The MASTER GAIN control on the Decoder will adjust the sound equally from all four speakers.

The rear system volume control can be considered the front-to-rear balance control. Adjust the rear sound level up or down slightly to move the balance point forward or backward in the room for the best effect. Experiment with your specific equipment and room acoustics to get the most favorable sound.

For normal straight through two-channel operation, turn the front system tape monitor switch off. The ac power to the rear system and the Decoder may also be turned off.

If a tape recorder is connected to the Decoder as part of the system, you can record conventional two-channel tapes, and play tapes through either the two-channel or four-channel system. The signals going to the tape recorder are identical to those coming from the tape out jacks on the front system, where the recorder normally would be connected.

If the Decoder FUNCTION switch is in the TAPE MONITOR position, the output of the tape recorder will play back through the front system in normal two-channel fashion. If the FUNCTION switch is in the TAPE DECODE position, the output of the two-channel tape recorder will be decoded into four channels just as a record or FM broadcast is decoded in the SOURCE DECODE position.

If a discrete four-channel tape machine is part of the system, the Decoder is not required for four-channel tape playback. Normally, the four outputs of such a tape recorder are connected to the auxiliary inputs of the amplifiers.

IN CASE OF DIFFICULTY

This section of the Manual is divided into two parts. This first part, titled "General," describes what to do about any difficulties that might occur right after the unit is assembled. The second part, titled "Troubleshooting Chart," lists a number of possible difficulties that could arise. It also lists the possible causes for these difficulties.

NOTES:

1. If it becomes necessary to remove the circuit board for any reason, the line cord strain relief and phono socket assembly must be removed first.
2. Should it ever become necessary to remove the IC from its connectors, slide a screwdriver blade under the IC; then gently lift the IC out of the connectors.

GENERAL

The following paragraphs deal with the types of difficulties that may show up right after the kit is assembled, before you can put it into operation. These difficulties are most likely to be caused by assembly errors or faulty soldering.

The following checks will help you locate any error of this type that might have been made.

NOTE: Refer to the "Kit Builders Guide" for Service and Warranty information. Refer to the "X-Ray View" on Page 34 for the physical location of parts.

1. Recheck the wiring. Trace each lead in colored pencil on the Pictorial as it is checked. It is frequently helpful to have a friend check your work. Some one who is not familiar with the unit may notice something consistently overlooked by the builder.

2. About 90% of the kits that are returned for repair, do not function properly due to poor connections and soldering. Therefore, many troubles can be eliminated by reheating all connections to make sure that they are soldered as described in the "Soldering" section of the "Kit Builders Guide."
3. Check the values of the parts. Be sure that the proper part has been wired into the circuit, as shown in the pictorial diagrams and as called out in the wiring instructions.
4. Check for bits of solder, wire ends, or other foreign matter which may be lodged in the wiring or between the foils on the circuit board.
5. If, after careful checks, the trouble is still not located and a voltmeter is available, check voltage readings against those shown on the Schematic Diagram (fold-out from Page 35), "Voltage Chart" on Page 36, or the "X-Ray View" on Page 34. NOTE: All voltage readings were taken with a high impedance voltmeter. Voltages may vary as much as $\pm 20\%$.
6. Check the transistor with a transistor tester, or by substitution of transistors of the same types known to be good.
7. A review of the "Circuit Description" will prove helpful in indicating where to look for trouble.

NOTE: In an extreme case where you are unable to resolve a difficulty, refer to the "Service" section and Warranty of the "Kit Builders Guide" and to the "Factory Repair Service" information on Page 31 of this Manual.

Troubleshooting Chart

DIFFICULTY	POSSIBLE CAUSE
A. Low resistance at emitter of Q1.	<ol style="list-style-type: none"><li data-bbox="882 280 1262 302">1. Transistor Q1 installed incorrectly.<li data-bbox="882 334 1169 355">2. IC1 installed incorrectly.<li data-bbox="882 387 1245 440">3. Solder bridge between foils from E of Q1 to pin 14 of IC1.
B. Low resistance at base of Q1.	<ol style="list-style-type: none"><li data-bbox="882 472 1262 493">1. Transistor Q1 installed incorrectly.<li data-bbox="882 525 1063 546">2. Capacitor C9.<li data-bbox="882 578 1047 600">3. Diode ZD1.<li data-bbox="882 632 1063 653">4. Capacitor C8.<li data-bbox="882 685 1096 706">5. Diode D1 or D2.
C. Low resistance at collector of Q1.	<ol style="list-style-type: none"><li data-bbox="882 744 1262 766">1. Transistor Q1 installed incorrectly.<li data-bbox="882 798 1063 819">2. Capacitor C8.<li data-bbox="882 851 1096 872">3. Diode D1 or D2.<li data-bbox="882 904 1047 925">4. Diode ZD1.<li data-bbox="882 957 1063 978">5. Capacitor C9.

DIFFICULTY	POSSIBLE CAUSE
D. Unit completely dead. Pilot lamp does not light.	<ol style="list-style-type: none"><li data-bbox="915 194 1202 213">1. Line cord not plugged in.<li data-bbox="915 218 1290 237">2. Master Gain control turned to Off:<li data-bbox="915 275 1083 294">3. Fuse blown.
E. Pilot lamp not lighted. Output OK.	<ol style="list-style-type: none"><li data-bbox="915 329 1083 348">1. Resistor R9.<li data-bbox="915 384 1070 403">2. Pilot lamp.
F. No output. Pilot lamp lights.	<ol style="list-style-type: none"><li data-bbox="915 438 1199 456">1. IC1 installed incorrectly.<li data-bbox="915 493 1265 539">2. No voltage or low voltage at pin 14 of IC1.
G. No output. No voltage at pin 14 of IC1.	<ol style="list-style-type: none"><li data-bbox="915 574 1290 593">1. Transistor Q1 installed incorrectly.<li data-bbox="915 598 1163 617">2. Capacitor C8 or C9.<li data-bbox="915 653 1179 672">3. Resistors R10 or R11.<li data-bbox="915 708 1125 727">4. Diode D1 or D2.
H. Too low or too high a voltage at base and collector of Q1.	<ol style="list-style-type: none"><li data-bbox="915 764 1219 783">1. See G2, G3, and G4 above.<li data-bbox="915 819 1136 838">2. Zener diode ZD1.

FACTORY REPAIR SERVICE

You can return your completed kit to the Heath Company Service Department to have it repaired for a minimum service fee. (Kits that have been modified will not be accepted for repair.) Or, if you wish, you can deliver your kit to a nearby Heathkit Electronic Center. These centers are listed in your Heathkit catalog.

To be eligible for replacement parts under the terms of the warranty, equipment returned for factory repair service, or delivered to a Heathkit Electronic Center, must be accompanied by the invoice or the sales slip, or a copy of either. If you send the original invoice or sales slip, it will be returned to you.

If it is not convenient to deliver your kit to a Heathkit Electronic Center, please ship it to the factory at Benton Harbor, Michigan and observe the following shipping instructions:

Prepare a letter in duplicate, containing the following information:

- Your name and return address.
- Date of purchase.
- A brief description of the difficulty.
- The invoice or sales slip, or a copy of either.
- Your authorization to ship the repaired unit back to you C.O.D. for the service and shipping charges, plus the cost of parts not covered by the warranty.

Attach the envelope containing one copy of this letter directly to the unit before packaging, so that we do not overlook this important information. Send the second copy of the letter by separate mail to Heath Company, Attention: Service Department, Benton Harbor, Michigan 49022.

Check the equipment to see that all parts and screws are in place. Then, wrap the equipment in heavy paper. Place the equipment in a strong carton, and put at least THREE INCHES of resilient packing material (shredded paper, excelsior, etc.) on all sides, between the equipment and the carton. Seal the carton with gummed paper tape, and tie it with a strong cord. Ship it by prepaid express, United Parcel Service, or insured parcel post to:

Heath Company
Service Department
Benton Harbor, Michigan 49022

SPECIFICATIONS

Gain (control Maximum)	Unity.
Maximum Input Signal	2.5 V rms.
Frequency Response	10 - 100,000 Hz; +0 - .5 dB.
Signal to Noise Ratio, (at .25 V input)	Greater than 70 dB, wideband.
Total Harmonic Distortion, (at .25 V input)	Less than .15%.
Intermodulation Distortion, (at .25 V input)	Less than .25%.
Input Impedance	50,000 ohms minimum.
Output Impedance	3,000 ohms*.
Controls	Master Gain/Power ON-Off switch, Function switch.
Dimensions (overall)	2-1/2" high, 5-3/16" wide, 7" deep.
Power Requirements	105 - 125 V, 50-60 Hz, 4 watts.
Weight	1 lb. 9 oz.

*Impedance of input connected to Decoder output should exceed 25,000 ohms.

The Heath Company reserves the right to discontinue instruments and to change specifications at any time

without incurring any obligation to incorporate new features in instruments previously sold.

CIRCUIT DESCRIPTION

Four-channel program material is fed into an encoder which, through algebraic summation in a matrix network, derives the two desired composite signals. These composite signals may then be recorded on standard stereo records or tape, or be broadcast over conventional stereo FM stations. It is the Decoder that separates these composite signals into four-channel program material again. The encoding/decoding process adds negligible distortion, noise, phase shift or other signal degradation and requires no change in bandwidth.

Refer to the Schematic Diagram (fold-out from Page 35) while you read the following description.

SIGNAL PATHS

Signals connected to the Left Input or Left Tape Out jack are selected by the Function switch and connected to the Master Gain control, R1. R1 controls the signal level that coupling capacitor C1 passes to pin 2 of IC1. Part of the signal passes through resistor R3 to pin 6 of IC1.

Similarly, Right Input or Right Tape Out signals are connected to the Master Gain control R2 and the selected level is coupled through C2 to pin 4 of IC1. A part of this signal is coupled through resistor R4 to pin 6 of IC1.

IC1 contains a matrix network that acts upon the signals in a manner complementary to the encoder and produces four distinct channels from either regular or encoded two-channel sources.

Left front information comes from pin 12 of IC1 and couples through C3 to the Function switch. With the Function switch in either decode position, the signal passes to the Left Front Out jack.

Right front information comes from pin 11 of IC1 and couples through C4 and the Function switch to the Right Front Out jack.

Left rear information comes from pin 10 at IC1 and couples through C5 to the Left Rear Out jack.

Right rear information comes from pin 9 of IC1 and couples through C6 to the Right Rear Out jack.

Resistors R5, R7, R8 and R6 discharge any dc voltage present on output capacitors C3, C4, C5, and C6.

In the Tape Monitor position of the Function switch, the Tape In source is routed directly to the Front Out jack of each channel. There is no output on the Rear Out jacks.

Power is supplied to pin 14 of IC1 directly from the power supply.

POWER SUPPLY





The full-wave rectified output from the power supply is closely regulated to provide IC1 with stable, hum free, dc power.

The line current passes through a 1/16-ampere slow-blow fuse, the power switch, the primary winding of transformer T1, and the pilot lamp circuit which parallels the primary winding. Resistor R9 is dropping resistor for pilot lamp PL1.

The transformer secondary winding supplies 53 volts ac that is rectified by diodes D1 and D2 and then filtered by capacitor C8. The resulting 29 volts dc is connected to the collector of series regulator transistor Q1. Resistors R10 and R11, and diode ZD1 hold the base of Q1 at 20 volts dc to provide an output voltage of 19.4 volts dc at the emitter of Q1. Capacitor C9 provides additional filtering.

SCHEMATIC OF THE HEATHKIT® STEREO-4 DECODER MODEL AD-2002

NOTES:

1. ALL RESISTORS ARE 1/2 WATT. RESISTOR VALUES ARE IN OHMS (K=1000).
2. ALL CAPACITORS VALUES ARE IN μF .
3.  THIS SYMBOL INDICATES A POSITIVE DC VOLTAGE MEASUREMENT TAKEN WITH A HIGH IMPEDANCE VOLT METER, FROM THE POINT INDICATED TO CIRCUIT GROUND (G ON THE CIRCUIT BOARD). VOLTAGES MAY VARY $\pm 20\%$.
4. REFER TO THE X-RAY VIEW FOR THE PHYSICAL LOCATION OF PARTS.
5.  THIS SYMBOL DENOTES CIRCUIT BOARD GROUND.
6.  THIS SYMBOL DENOTES CHASSIS GROUND.
7.  THIS SYMBOL DENOTES CONNECTION TO CIRCUIT BOARD.
8.  THIS SYMBOL DENOTES CLOCKWISE ROTATION OF CONTROL AND SWITCH WHEN VIEWED FROM THE FRONT.

