

MODEL **GC-1005 Electronic Clock**

HEATHKIT[®]

ASSEMBLY MANUAL



PRICE \$2.00

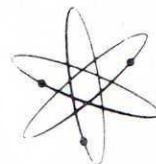

Copyright © 1972
Heath Company
All rights reserved

I-595-1500-03

Dear Customer:

The Heathkit electronic product you have purchased is one of the best performing electronic products in the world.

Here's how we aim to keep it that way:

Your Heathkit Warranty

During your first 90 days of ownership, any parts which we find are defective, either in materials or workmanship, will be replaced or repaired free of charge. And we'll pay shipping charges to get those parts to you — anywhere in the world.

If we determine a defective part has caused your Heathkit electronic product to need other repair, through no fault of yours, we will service it free — at the factory, at any retail Heathkit Electronic Center, or through any of our authorized overseas distributors.

This protection is exclusively yours as the original purchaser. Naturally, it doesn't cover damage by use of acid-core solder, incorrect assembly, misuse, fire, flood or acts of God. But, it does insure the performance of your Heathkit electronic product anywhere in the world — for most any other reason.

After-Warranty Service

What happens after warranty? We won't let you down. If your Heathkit electronic product needs repairs or you need a part, just write or call the factory, your nearest retail Heathkit Electronic Center, or any Heath authorized overseas distributor. We maintain an inventory of replacement parts for each Heathkit model at most locations — even for many models that no longer appear in our current product line-up. Repair service and technical consultation are available through all locations.

We hope you'll never need our repair or replacement services, but it's nice to know you're protected anyway — and that cheerful help is nearby.

Sincerely,

HEATH COMPANY
Benton Harbor, Michigan 49022

Assembly
and
Operation
of the



ELECTRONIC CLOCK
MODEL GC-1005

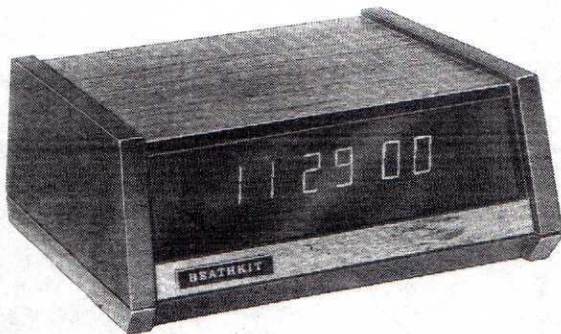

TABLE OF CONTENTS

Introduction	2
Parts List	2
Assembly Notes	4
Step-by-Step Assembly	5
Cabinet Top	15
Cabinet Bottom	16
Alternate Line Voltage Wiring	17
Other Wiring	17
Decorating	20
Initial Tests	21
Operation	22
In Case of Difficulty	23
Troubleshooting Chart	24
Specifications	25
Circuit Fundamentals	26
Chassis Photograph	27
Circuit Board X-Ray Views	28
Circuit Board Voltage Charts	30
Identification Chart	31
Schematic . . . (fold-out from page)	31
Warranty	Inside front cover
Customer Service	Inside rear cover

HEATH COMPANY
BENTON HARBOR, MICHIGAN 49022

INTRODUCTION

The Heathkit Model GC-1005 digital Electronic Clock has many attractive features, including: a wiring option that lets it display either 12-hour or 24-hour time; an AM-PM alarm with snooze alarm; a 6-digit, easy-to-read display; a power interruption indication; a 50 or 60 Hz wiring option; and a 120-volt or 240-volt wiring option. The heart of the Clock is an MOS/LSI* integrated circuit that performs all the logic functions of keeping time.

A simple wiring option lets your Clock display either 12-hour or 24-hour time. The clock "knows" the difference between AM and PM and will only sound the alarm for the one time (either AM or PM, but not both) in 24 hours that you desire. The snooze alarm waits approximately seven minutes each time it is reset, until it sounds again.

*MOS/LSI (Metal Oxide Semiconductor/Large Scale Integration)

The readout tubes clearly display the time on a sloped surface, and the 6-digit display shows all 8's if there is a significant power line interruption. The Clock can be wired to operate from either a 50 Hz or a 60 Hz power line, or 120 volts or 240 volts AC.

Attractive, modern styling; small size; and solid-state dependability make this Clock ideally suited for your office, your home, or almost anywhere.

Refer to the "Kit Builders Guide" for complete information on unpacking, parts identification, tools, wiring, soldering, and step-by-step assembly procedures.

PARTS LIST

Check each part against the following list. The key numbers correspond to the numbers in the Parts Pictorial (fold-out from Page 5). Any part that is packaged in an individual envelope with the part number on it should be placed back in the envelope after it is identified until it is called for in a step.

CAUTION: The integrated circuit (#443-601) can be damaged by static voltage. Do not handle it until you are told to do so.

To order a replacement part, use the Parts Order Form furnished with this kit. If a Parts Order Form is not available, refer to "Replacement Parts" inside the rear cover of the Manual.

KEY PART No.	PARTS No.	PER KIT	DESCRIPTION	PRICE Each	KEY PART No.	PARTS No.	PER KIT	DESCRIPTION	PRICE Each
RESISTORS									
NOTE: Each of the following resistors has a 10% tolerance unless otherwise noted. 10% is indicated by a silver fourth color band, while 5% is indicated by a gold band.									
1/4-Watt									
A1	1-46-12	14	27 k Ω (red-violet-orange)	.10	A2	1-45	1	220 Ω (red-red-brown)	.10
A1	1-12-12	1	82 k Ω (gray-red-orange)	.10	A2	1-13	1	2700 Ω (red-violet-red)	.10
A1	1-90-12	2	91 k Ω , 5% (white-brown-orange)	.10	A2	1-114	2	8200 Ω , 5% (gray-red-red)	.20
A1	1-32-12	4	100 k Ω (brown-black-yellow)	.10	A2	1-109	3	12 k Ω , 5% (brown-red-orange)	.20
A1	1-16-12	7	180 k Ω (brown-gray-yellow)	.10	A2	1-162	1	15 k Ω , 5% (brown-green-orange)	.10
					A2	1-22	4	22 k Ω (red-red-orange)	.10
					A2	1-23	1	27 k Ω (red-violet-orange)	.10
					A2	1-47	2	56 k Ω (green-blue-orange)	.10
					A2	1-121	13	120 k Ω (brown-red-yellow)	.10
1/2-Watt									



KEY PART No.	PARTS No.	Per Kit	DESCRIPTION	PRICE Each
Resistors (cont'd.)				
A2	1-30	7 6✓	270 kΩ (red-violet-yellow)	.10
A2	1-33	8 6✓	470 kΩ (yellow-violet-yellow)	.10
A2	1-35	9 6✓	1 MΩ (brown-black-green)	.10

CAPACITORS				
A3	20-100	1✓	30 pF mica	.20
A4	21-163	6✓	.001 μF disc	.10
A5	27-63	1✓	.022 μF Mylar*	.10
A6	25-30	1✓	Dual 20 μF electrolytic	1.00
A7	25-241	1✓	1200 μF electrolytic	.90

DIODES				
B1	56-25	1✓	1N4166A zener	1.00
B1	56-56	8✓	1N4149	.20
B1	57-27	1✓	1N2071	.50
B1	57-65	2✓	1N4002	.20

TRANSISTORS-INTEGRATED CIRCUIT				
NOTE: Transistors and integrated circuits are marked for identification in one of the following four ways:				
1. Part number.				
2. Type number. (In integrated circuits this refers only to the numbers; the letters may vary.)				
3. Part number and type number.				
4. Part number with a type number other than the one listed.				
B2	417-811	7✓	MPS-L01 transistor	.40
B2	417-295	6✓	MPS-L51 transistor	.50
B2	417-801	8✓	MPS-A20 transistor	.20
B3	443-601	1✓	MK5017AA integrated circuit	15.00

SWITCHES-INSULATORS				
B4	60-1	2 1✓	SPST switch	.20
	60-6	3 3✓	SPST switch with spring return	.30
B5	60-2	1 2✓	DPDT switch	.30
B6	75-52	4 6✓	Switch insulator	.10
B7	75-103	- 1✓	Fish paper, 5-1/2" x 1-7/8"	.10
B8	75-93	- 1✓	Fish paper, 1" x 1"	.10
B9	75-138	- 4✓	Rubber foot	.10

CORD-WIRE-CABLE				
	89-44	1✓	Line cord	.55

KEY PART No.	PARTS No.	Per Kit	DESCRIPTION	PRICE Each
Cord-Wire-Cable (cont'd.)				
	340-11	1✓	Bare wire (used only for soldering iron tip)	.05/ft
	344-50	1	Black wire	.05/ft
	347-55	1✓	8-wire cable	.25/ft

HARDWARE				
C1	250-420	7✓	2-32 x 1/4" self-tapping screw	.05
C2	250-52	3✓	4-40 x 1/4" screw	.05
C3	252-2	3✓	4-40 nut	.05
C4	254-9	3✓	#4 lockwasher	.05
C5	250-276	12✓	6-32 x 3/8" flat head screw	.05
C6	250-381	2✓	6-32 x 3/8" black screw	.05
	250-89	1✓	6-32 x 3/8" screw	.05
C7	250-1156	4	6-20 x 2-1/4" self-tapping screw	.10
C8	252-3	3✓	6-32 nut	.05
C9	253-60	2✓	#6 flat washer	.05
C10	254-1	5✓	#6 lockwasher	.05
C11	259-1	6✓	#6 solder lug	.05

CIRCUIT BOARDS-CABINET-LABELS				
	85-1239-3	1✓	Main circuit board	1.65
	85-1240-2	1✓	Display circuit board	.85
D1	92-77	1✓	Cabinet top	1.20
D2	92-78	1✓	Cabinet bottom	1.10
D3	390-341	1✓	Heathkit label	.10
	390-362	1✓	Fuse label	.10
	390-926	1✓	Cord disconnect label	.15
	390-995	1✓	Wood-grain trim	.40
	391-34	1✓	Blue and white label	

MISCELLANEOUS				
	54-820	1✓	Power transformer	4.60
E1	204-1876	2✓	Angle bracket	.15
E2	205-141	2✓	Tool plate	.10
E3	258-167	2✓	Speaker clamp	.05
E4	346-6	1✓	Sleeving	.05
E5	401-163	1✓	Speaker	1.40
E6	411-286	3✓	Display tube	5.00
E7	412-11	1✓	Neon lamp	.20
E8	421-40	1✓	3/16-ampere slow-blow fuse	.40
E9	431-43	1✓	Terminal strip	.10
E10	432-134	56 9✓	Connector pin	.10
E11	432-144	24 7✓	Integrated circuit (IC) connector	.01
E12	432-199	1 8✓	Wire nut	.10

*DuPont Registered Trademark

KEY PART No.	PARTS No.	PARTS Per Kit	DESCRIPTION	PRICE Each
Miscellaneous (cont'd.)				
E13	446-609	1	Window	1.20
	490-5	1	Nut starter	.10
	597-260	1	Parts Order Form	
	597-308	1	Kit Builders Guide	
			Manual (See front cover for part number.)	2.00
			Solder (Additional 6' rolls of solder, #331-13, can be ordered for 25 cents each.)	

The prices apply only on purchases from the Heath Company where shipment is to a U.S.A. destination. Add 10% (minimum 25 cents) to the price when ordering from a Heathkit Electronic Center to cover local sales tax, postage, and handling. Outside the U.S.A., parts and service are available from your local Heathkit source and will reflect additional transportation, taxes, duties, and rates of exchange.

ASSEMBLY NOTES

- Before you start to assemble this kit, read the wiring, soldering, and step-by-step assembly information in the "Kit Builders Guide."
- Due to the small foil area around the circuit board holes and the small areas between foils, it will be necessary to use the utmost care to prevent solder bridges between adjacent foil areas. Use only a minimum amount of solder and use no larger than a 25-watt soldering iron with a small tip. Allow it to reach operating temperature, and then apply it only long enough to make a good solder connection.
- If a small wattage, small-tip soldering iron is not available, proceed as follows: Be sure your soldering iron is cool. Wrap the large bare wire (supplied) tightly around the soldering iron tip as shown in Figure 1. Allow approximately 1/4" of wire to extend beyond the end of the soldering iron. Cut the wire end to a

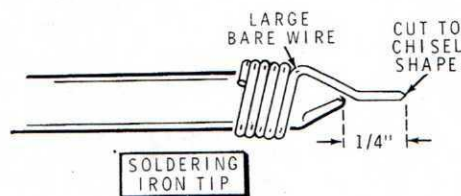

Figure 1

chisel shape as shown. Occasionally apply solder to the turns of large bare wire to achieve a good heat transfer.

- Resistors will be called out by their resistance value in Ω , $k\Omega$, or $M\Omega$, and color code.
- Capacitors will be called out by their capacitance value (in pF or μF) and type (disc, mica, Mylar, or electrolytic).



STEP-BY-STEP ASSEMBLY

START



Position the display circuit board as shown in Pictorial 1-1. Then complete each step on the Pictorial.

NOTE: In the following steps, use 1/4-watt resistors (the smaller resistors) unless directed otherwise.

1) 180 kΩ (brown-gray-yellow).

2) 27 kΩ (red-violet-orange).

3) 91 kΩ, 5% (white-brown-orange).

4) 180 kΩ (brown-gray-yellow).

SAFETY WARNING: Avoid eye injury when you clip off excess leads. We suggest that you wear glasses, or at least clip the leads so the ends will not fly toward your eyes.

5) Solder the leads to the foil and cut off the excess lead lengths. Save these excess lead lengths for the next four steps.

NOTE: In the following four steps, use cut off resistor leads as shown. Solder each lead as it is installed.

6) 3/4" resistor lead at K. See the inset drawing.

7) 3/4" resistor lead at L.

8) 3/4" resistor lead at N.

9) 3/4" resistor lead at P.

10) Make sure the four previously installed wires are still down against the circuit board and did not move during soldering.

11) 180 kΩ (brown-gray-yellow).

12) 82 kΩ (gray-red-orange).

13) 27 kΩ (red-violet-orange).

14) 100 kΩ (brown-black-yellow).

15) 27 kΩ (red-violet-orange).

16) Solder the leads to the foil and cut off the excess lead lengths.

FOR GOOD SOLDERED CONNECTIONS, YOU MUST KEEP THE SOLDERING IRON TIP CLEAN... WIPE IT OFTEN WITH A DAMP SPONGE OR CLOTH.

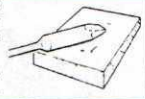

CONTINUE



17) 180 kΩ (brown-gray-yellow).

18) 27 kΩ (red-violet-orange).

19) 91 kΩ, 5% (white-brown-orange).

20) 27 kΩ (red-violet-orange).

21) 100 kΩ (brown-black-yellow).

22) 470 kΩ, 1/2-watt (yellow-violet-yellow).

23) Solder the leads to the foil and cut off the excess lead lengths.

24) 470 kΩ, 1/2-watt (yellow-violet-yellow).

25) 470 kΩ, 1/2-watt (yellow-violet-yellow).

26) 470 kΩ, 1/2-watt (yellow-violet-yellow).

27) 470 kΩ, 1/2-watt (yellow-violet-yellow).

28) 470 kΩ, 1/2-watt (yellow-violet-yellow). Be sure the leads of this resistor do not touch any other resistor leads.

29) Solder the leads to the foil and cut off the excess lead lengths.

30) 180 kΩ (brown-gray-yellow).

31) 180 kΩ (brown-gray-yellow).

32) 180 kΩ (brown-gray-yellow).

33) Solder the leads to the foil and cut off the excess lead lengths.

INSET



K

L

N

P

PART NUMBER

PICTORIAL 1-1

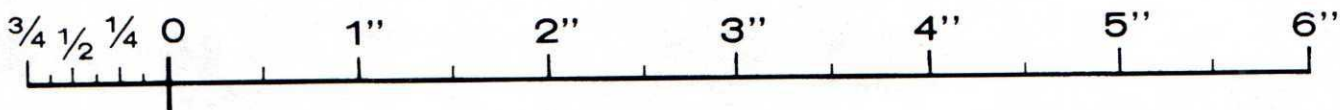

PARTS PICTORI

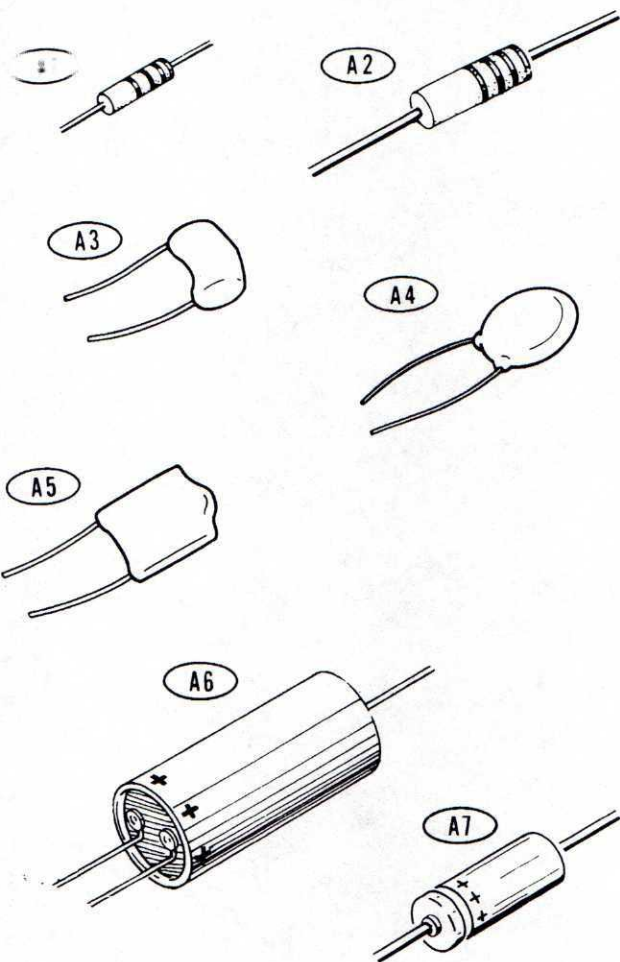

B1

NOTE: HEATH PART NUMBERS ARE STAMPED ON MOST DIODES.

B2

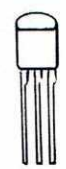

B3

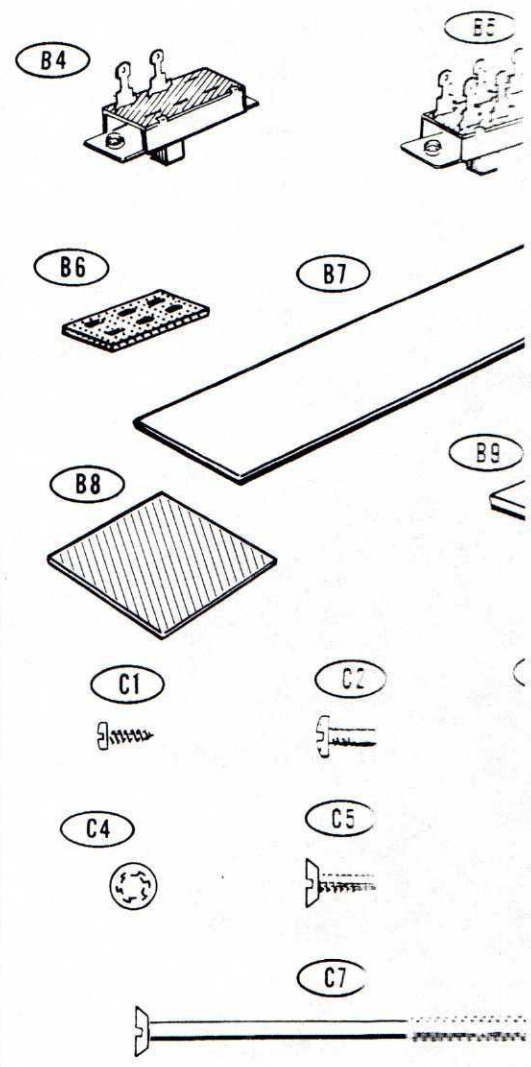
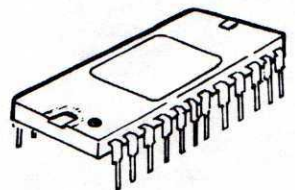

C8



C9



C10



D1

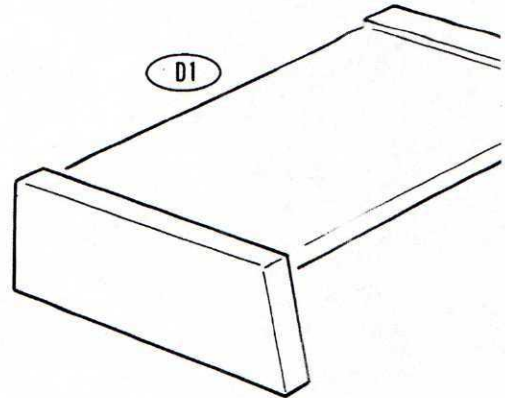

ARTS PICTORIAL

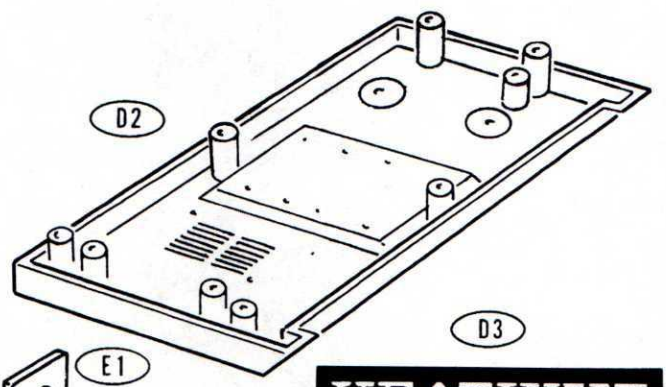
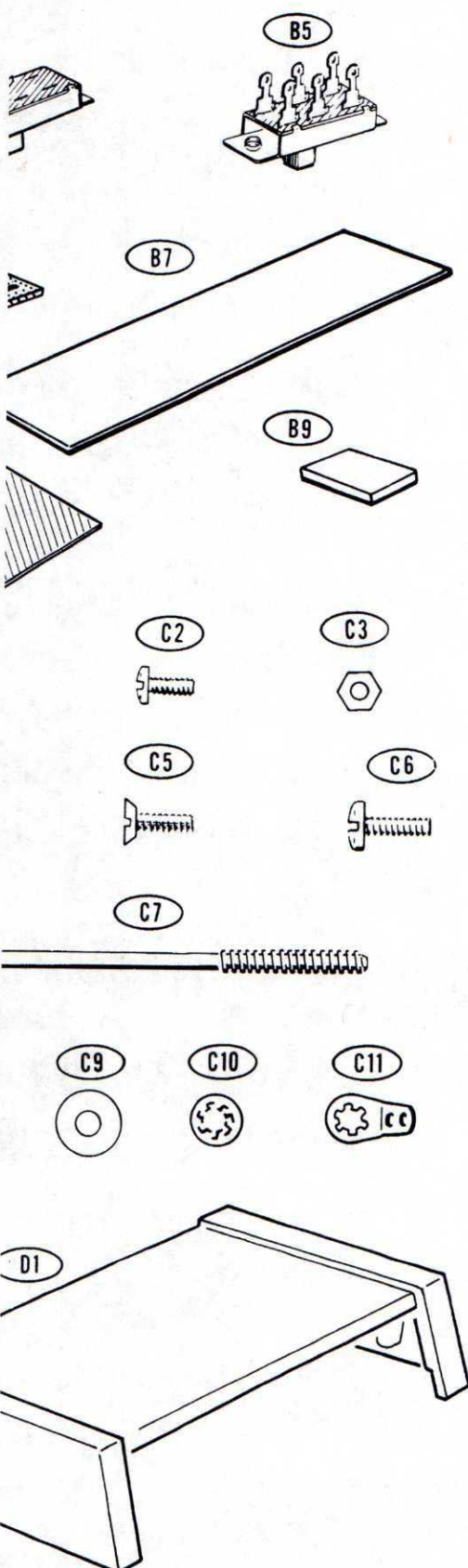

HEATHKIT

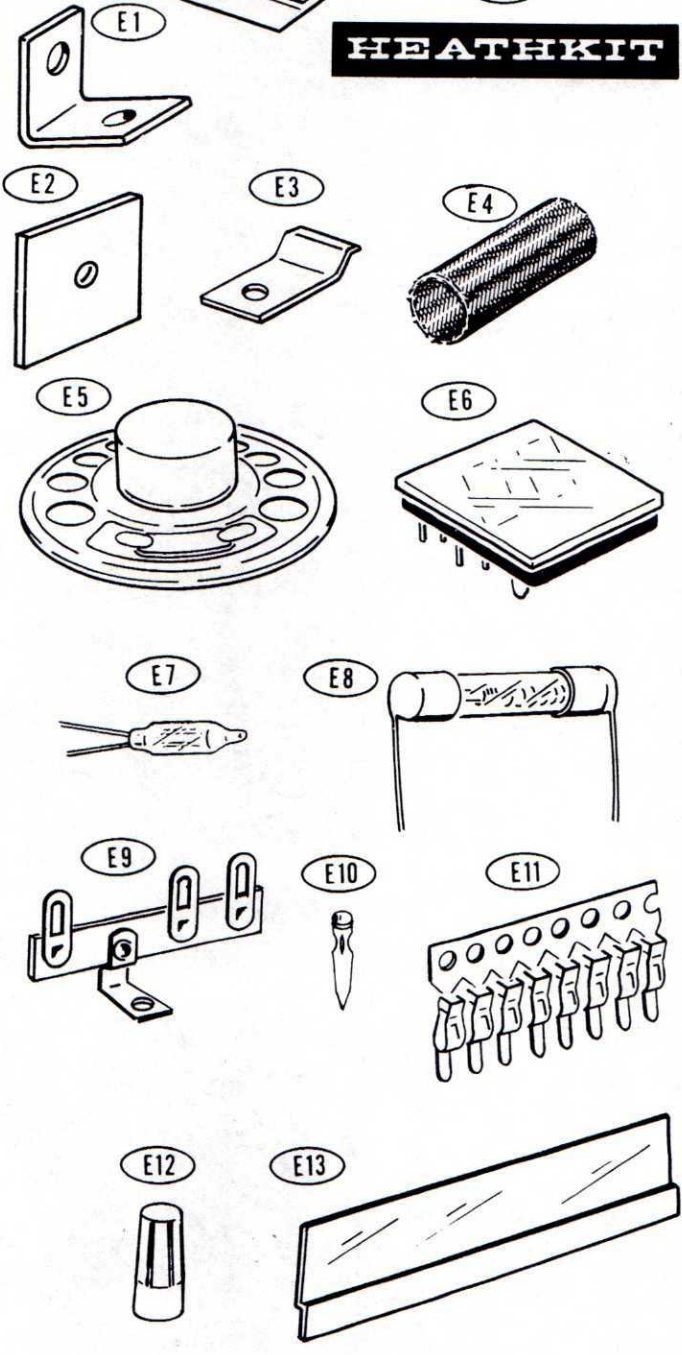

START



- NOTES:**
1. Use the plastic nut starter supplied with this kit to hold and start 6-32 and 4-40 nuts on screws.
 2. You will install two angle brackets on this circuit board. Do not be concerned if the brackets touch nearby foils.

✓) Angle bracket. Use a 4-40 x 1/4" screw, a #4 lockwasher, and a 4-40 nut.

4-40 x 1/4" SCREW
#4 LOCKWASHER
4-40 NUT

✓) Cut one lead of a 27 kΩ, 1/4-watt (red-violet-orange) resistor to 3/8". You will use this short lead in the next three steps.

3/8" CUT

1. Sixteen connector pins at V101. Solder the pins to the foil. Be sure the pins are straight and even. Do not fill the pins with solder.

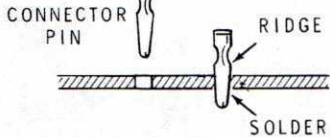

2. Push the 3/8" lead of the previously prepared resistor into each connector pin. This will open the connector pins slightly and make it easier to install the display tubes later.

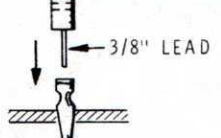

- ✓) Sixteen connector pins at V102. Solder each pin to the foil and push the short lead into each pin.

- ✓) Sixteen connector pins at V103. Solder each pin to the foil and push the short lead into each pin. Then discard the prepared 27 kΩ resistor.

- ✓) Angle bracket. Use a 4-40 x 1/4" screw, a #4 lockwasher, and a 4-40 nut.

CONTINUE



NOTE: In each of the following steps where a transistor is installed, line up the flat on the transistor with the flat on the circuit board and insert the transistor leads into the corresponding E, B, and C holes in the circuit board. Solder each transistor as it is installed and cut off the excess lead lengths.

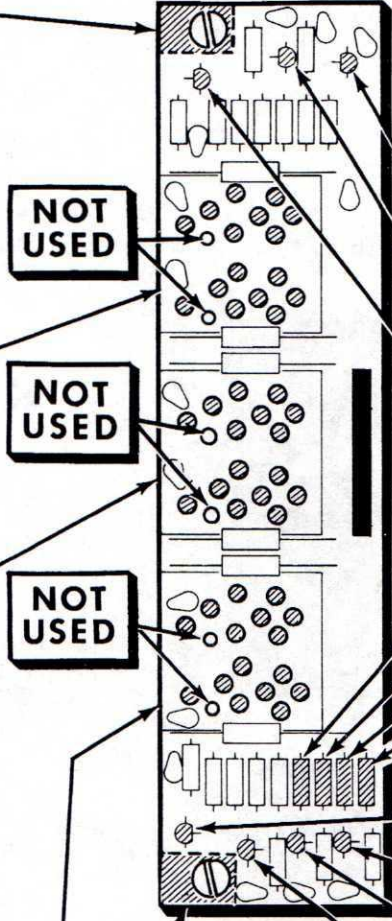
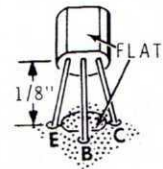

- ✓) MPS-L01 transistor (#417-811) at Q101.
 - ✓) MPS-L01 transistor (#417-811) at Q102.
 - ✓) MPS-L01 transistor (#417-811) at Q103.
 - ✓) 100 kΩ (brown-black-yellow).
 - ✓) 27 kΩ (red-violet-orange).
 - ✓) 100 kΩ (brown-black-yellow).
 - ✓) 27 kΩ (red-violet-orange).
 - ✓) Solder the leads to the foil and cut off the excess lead lengths.
 - ✓) MPS-L01 transistor (#417-811) at Q107.
 - ✓) MPS-L01 transistor (#417-811) at Q104.
 - ✓) MPS-L01 transistor (#417-811) at Q105.
 - ✓) MPS-L01 transistor (#417-811) at Q106.
 - ✓) Make sure all leads are soldered, and cut off any excess lead lengths. NOTE: Do not cut off the four leads that extend from the side of the circuit board.
 - ✓) Compare the foil area with the X-Ray View (on Page 28) to be sure there are no solder bridges.
- Temporarily set the circuit board aside.

PICTORIAL 1-2

FINISH

The steps performed in this Pictorial are in this area of the circuit board.

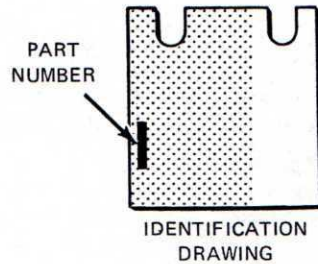

START

CONTINUE

- Position the main circuit board as shown in the identification drawing.
- NOTE: In the following steps, use 1/2-watt resistors unless directed otherwise.
- 2) 12 kΩ, 5% (brown-red-orange).
 - 2) Twelve 120 kΩ (brown-red-yellow) resistors.
 - 2) Solder the leads to the foil and cut off the excess lead lengths.

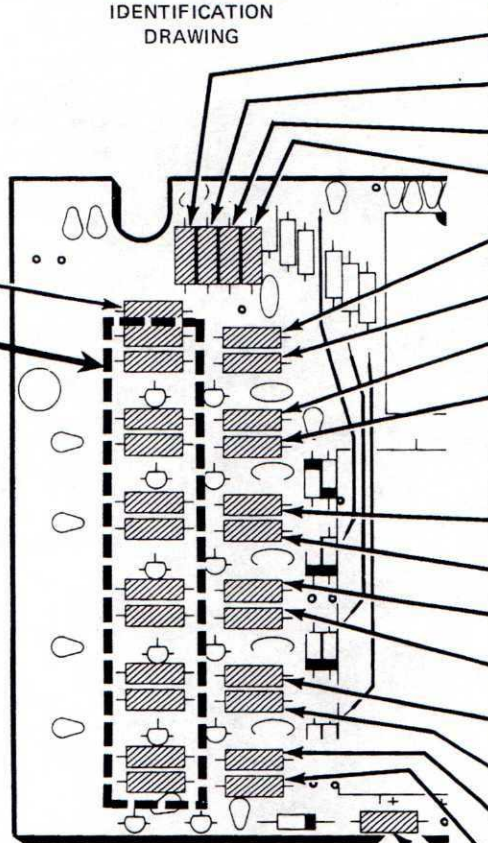

- 2) 22 kΩ (red-red-orange).
- 2) 22 kΩ (red-red-orange).
- 2) 22 kΩ (red-red-orange).
- 2) 12 kΩ, 5% (brown-red-orange).
- 2) 1 MΩ (brown-black-green).
- 2) 270 kΩ (red-violet-yellow).
- 2) 1 MΩ (brown-black-green).
- 2) 270 kΩ (red-violet-yellow).
- 2) Solder the leads to the foil and cut off the excess lead lengths.
- 2) 1 MΩ (brown-black-green).
- 2) 270 kΩ (red-violet-yellow).
- 2) 1 MΩ (brown-black-green).
- 2) 270 kΩ (red-violet-yellow).
- 2) 1 MΩ (brown-black-green).
- 2) 270 kΩ (red-violet-yellow).
- 2) 1 MΩ (brown-black-green).
- 2) 270 kΩ (red-violet-yellow).
- 2) 2700 Ω (red-violet-red).
- 2) Solder the leads to the foil and cut off the excess lead lengths.

PICTORIAL 2-1

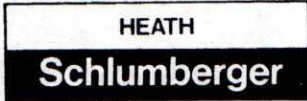

HEATH COMPANY
BENTON HARBOR, MICHIGAN 49022
PHONE 616-983-3961 TLX 72-9421

December 5, 1973

IMPORTANT NOTICE

Please make the following change in your Manual before you start to assemble the kit.

Page 8 — In the right-hand column, change the sixth step to read:

() 120 k Ω (brown-red-yellow).

Thank you,

HEATH COMPANY

GC-1005/595-1500-3
591-1329



The steps performed in this Pictorial are in this area of the circuit board.

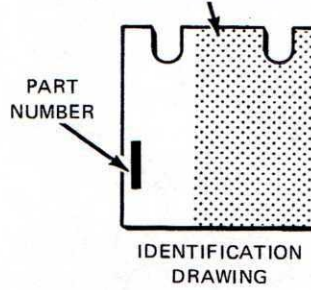

START

✓) Six 27 kΩ, 1/4-watt (red-violet-orange) resistors.

✓) Solder the leads to the foil and cut off the excess lead lengths.

NOTE: DIODES MAY BE SUPPLIED IN ANY OF THE FOLLOWING SHAPES. ALWAYS POSITION THE BANDED END AS SHOWN ON THE CIRCUIT BOARD.

BAND OR BANDS

✓) Eight 1N4149 diodes (#56-56).

✓) 1N2071 diode (#57-27) at D201.

✓) Solder the leads to the foil and cut off the excess lead lengths.

CONTINUE

✓) 15 kΩ, 5% (brown-green-orange).

✓) 22 kΩ (red-red-orange).

✓) 27 kΩ (red-violet-orange).

✓) 8200 Ω, 5% (gray-red-red).

✓) 56 kΩ (green-blue-orange).

✓) 120 kΩ, 5% (brown-red-yellow).

✓) 56 kΩ (green-blue-orange).

✓) 12 kΩ, 5% (brown-red-orange).

✓) Solder the leads to the foil and cut off the excess lead lengths.

✓) 8200 Ω, 5% (gray-red-red).

✓) 1N4002 diode (#57-65) at D203.

✓) 1N4002 diode (#57-65) at D202.

✓) 1N4166A zener diode (#56-25) at ZD201.

✓) 220 Ω (red-red-brown).

✓) Solder the leads to the foil and cut off the excess lead lengths.

PICTORIAL 2-2

CONTINUE

START

✓) Six MPS-L51 transistors (#417-295). As you install each transistor, solder the leads to the foil and cut off the excess lead lengths.

FLAT
1/4"
C B E

✓) Six MPS-A20 transistors (#417-801).

NOTE: When you install disc, mica, or Mylar capacitors, remove any excess coating from the leads. Use long-nose pliers to remove the coating.

REMOVE COATING EVEN WITH BOTTOM OF CAPACITOR BODY

✓) Six .001 μ F disc capacitors.

✓) Solder the leads to the foil and cut off the excess lead lengths.

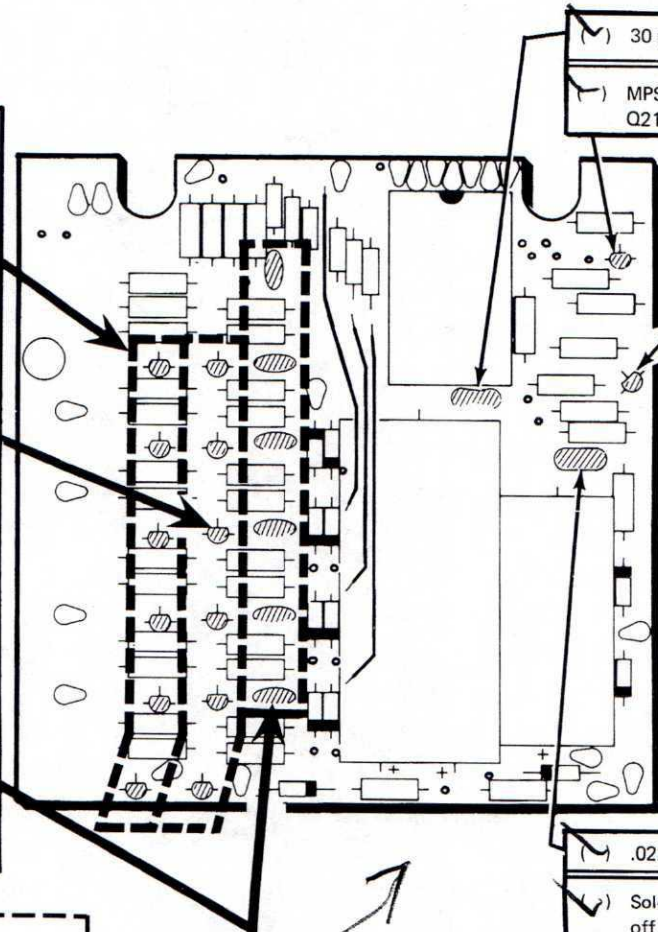

✓) 30 pF mica.

✓) MPS-A20 transistor (#417-801) at Q214.

✓) MPS-A20 transistor (#417-801) at Q213.

✓) .022 μ F Mylar.

✓) Solder the leads to the foil and cut off the excess lead lengths.

START

PICTORIAL 2-3

✓) Assemble the two tool plates together as shown. Use a 6-32 x 3/8" screw, two #6 lockwashers, and a 6-32 nut.

TOOL PLATE
6-32 NUT
6-32 x 3/8" SCREW
#6 LOCKWASHER

✓) NOTE: In the following steps you will prepare and install the IC connectors. Read and follow the instructions very closely.

✓) Cut two (2) strips of twelve (12) IC connectors.

CONNECTOR STRIP
12-CONNECTORS

PICTORIAL 2-4

CONTINUE

IMPORTANT: On the next page, use the following method to install the two IC connector strips.

A. Position the connector strips as shown.

CONNECTOR STRIP
CONNECTING BAND
CONNECTOR STRIP
MOUNTING LOCATION

B. Be sure the strips are perpendicular to the circuit board. Then turn the board over and solder the connectors to the foil.

START

The steps performed in this Pictorial are in this area of the circuit board.

Two strips of twelve connectors.

Use the assembled tool plates to remove the connecting bands. First bend each band inward, and then outward, as shown (several times if necessary). Do not bend the connectors.

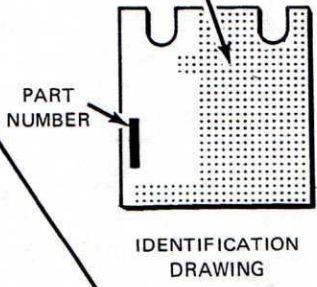

Cut a 5-1/2" length of 8-wire cable and separate the cable into eight individual wires. You will use these wires in the following steps.

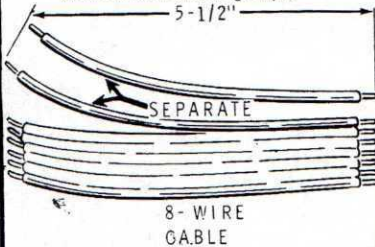

NOTE: In the following steps, when a wire is called for, cut the wire to the indicated length, remove 1/4" of insulation from the wire ends, twist the strands together, and apply a small amount of solder to the bare ends. Solder each wire as it is installed and cut off the excess bare wire ends.

- 2-5/8" brown wire.
- 2-3/8" red wire.
- 2-7/8" orange wire.
- 5-1/4" yellow wire from hole AX to hole BX. Route it as shown.
- 2-1/2" red wire from hole M to hole AN.

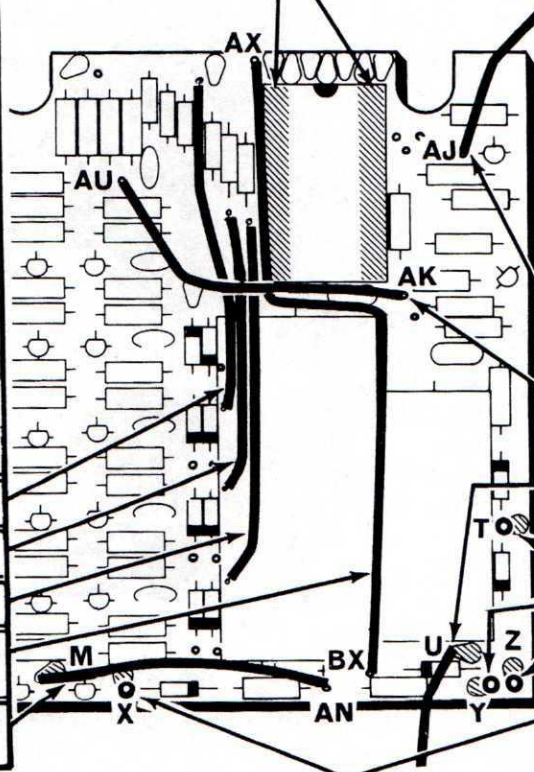

CONTINUE

- 3" gray wire at hole AJ. The free end will be connected later.
- 3" green wire from hole AU to hole AK.
- 5" violet wire at hole U. The free end will be connected later.
- Connector pin at hole T.
- Connector pin at hole Y.
- Connector pin at hole Z.
- Connector pin at hole X.
- Solder the pins to the foil. Also, be sure the wires are soldered and the excess ends cut off.
- Compare the foil area with the X-Ray View (on Page 29) to be sure there are no solder bridges.

PICTORIAL 2-5

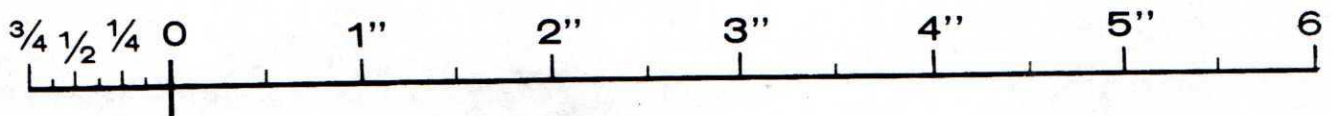



CONTINUE

START

(✓) 2-1/4" green wire from hole AT to hole AR. Do not shorten this wire.

(✓) 3" blue wire at hole J. The free end will be connected later.

(✓) Cut a 10" length of 8-wire cable and:

1. Separate the brown and red wires from the cable, leaving the brown wire connected to the red wire.
2. Separate the orange wire from the cable.
3. Separate the yellow wire from the cable.
4. Separate the green and blue wires from the cable.

Leave the green wire connected to the blue wire and the violet wire connected to the gray wire.

(✓) 8" orange wire at hole AS. The free end will be connected later.

NOTE: The power line frequency in the U.S.A. is 60 Hz. Do not perform the following step unless you live in an area (or a foreign country) that has a 50 Hz power line frequency.

() 3" yellow wire from hole BY to hole BZ.

NOTE: Most clocks indicate up to 12 hours (0-12) and then repeat. Do not perform the following step unless you want your Clock to indicate 24-hour time (0-24).

() 3-1/4" yellow wire from hole AY to hole AZ.

() Prepare the gray and violet wire pair as shown.

(✓) Install end A of the wire combination as shown.

Violet wire to hole AB.
Gray wire to hole AA.

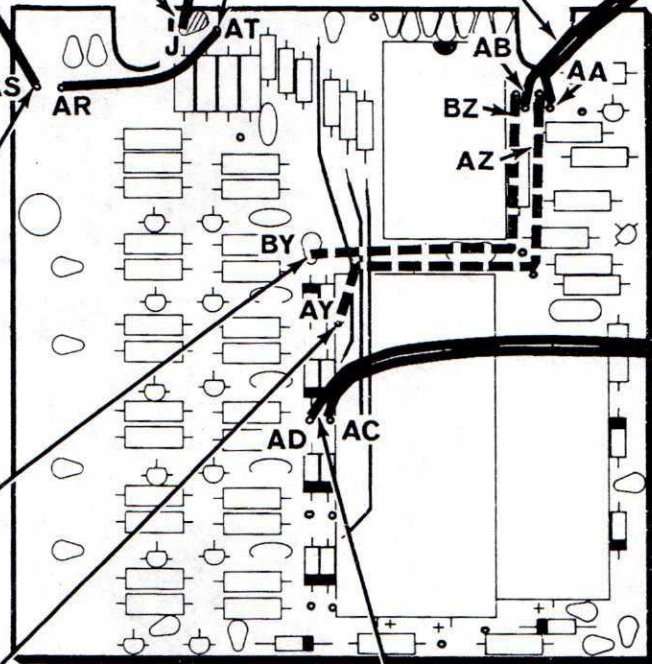

(✓) Cut the green and blue wire pair to a length of 9-1/2" and prepare the ends the same as the previous pair.

(✓) Install the wire combination as shown.

Blue wire to hole AD.
Green wire to hole AC.

(✓) Check to be sure all wires are soldered.

PICTORIAL 2-6

START



- (✓) Cut a 9-1/2" length of 8-wire cable and:

 1. Remove the gray wire from the cable.
 2. Remove the brown and red wires from the cable. (Leave these two wires connected together.)

- (✓) Prepare the remaining wires of the cable as shown in Detail 2-7A.

In the following steps, connect the wires of end A of the cable to the circuit board. End B will be connected later.

- (✓) Violet to hole AL.
- (✓) Orange to hole AE.
- (✓) Yellow to hole AF.
- (✓) Green to hole AH.
- (✓) Blue to hole AG.

NOTE: When you install electrolytic capacitors, match the positive (+) marked end with the positive (+) marking on the circuit board.

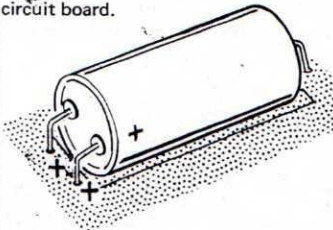

- (✓) Dual 20 μ F electrolytic. Install the capacitor under the previously installed cable.
- () 1200 μ F electrolytic.
- (✓) Solder the leads to the foil and cut off the excess lead lengths.

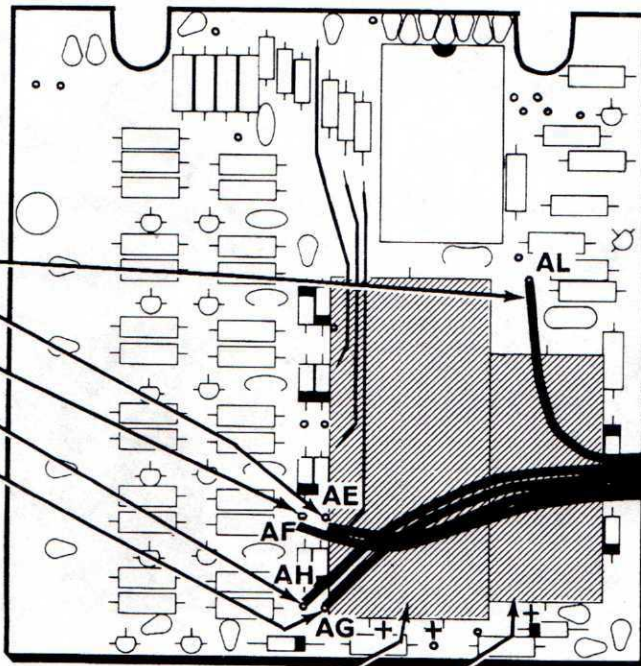

SEPARATE THE WIRES AS SHOWN.

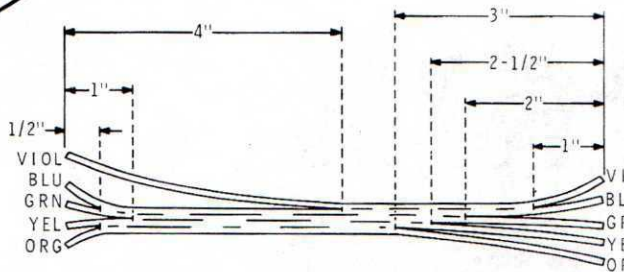

CUT THE WIRES AS SHOWN AND REMOVE 1/4" OF INSULATION FROM EACH WIRE END.

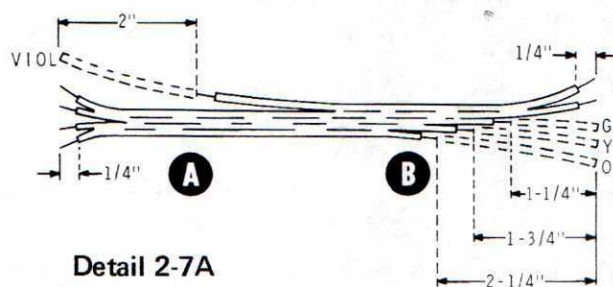

Detail 2-7A



PICTORIAL 2-7

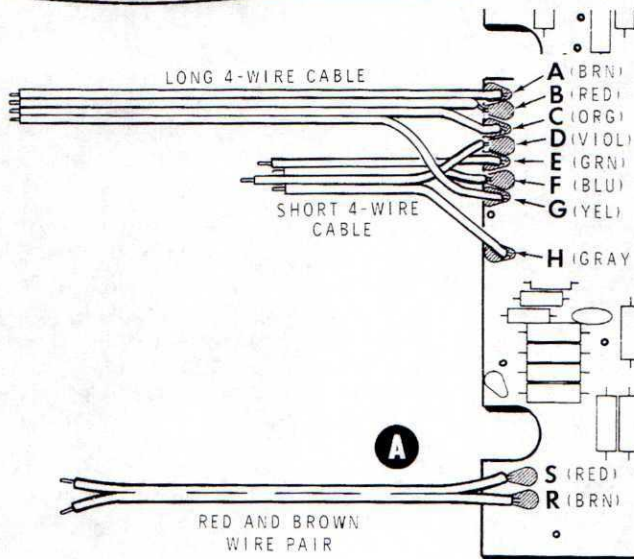
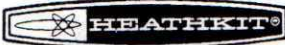

PICTORIAL 2-8

Refer to Pictorial 2-8 for the following steps.

- 1) Locate a red and brown wire pair and cut the pair to 6".

RED AND BROWN WIRE PAIR



Detail 2-8A

Refer to Detail 2-8A and prepare the wire ends as shown.

Refer to Pictorial 2-8 and connect end A of the red and brown wire pair to the main circuit board as follows:

- 1) Brown wire to hole R (S-1).
- 1) Red wire to hole S (S-1).
- 2) Cut a 9-1/2" length of 8-wire cable.
- 2) Refer to Detail 2-8B, separate the 8-wire cable into two 4-wire cables, and prepare the cables as shown.

Refer to Pictorial 2-8 and connect end A of the short 4-wire cable to the main circuit board as follows:

- 2) Gray wire to hole H (S-1).
- 2) Blue wire to hole F (S-1).
- 2) Green wire to hole E (S-1).
- 2) Violet wire to hole D (S-1).

Connect end A of the long 4-wire cable as follows:

- 2) Yellow wire to hole G (S-1).
- 2) Orange wire to hole C (S-1).
- 2) Red wire to hole B (S-1).
- 2) Brown wire to hole A (S-1).

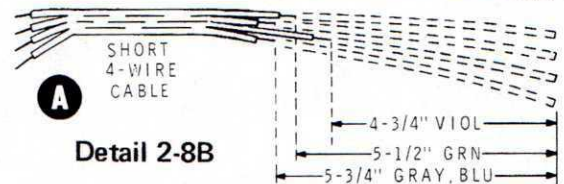
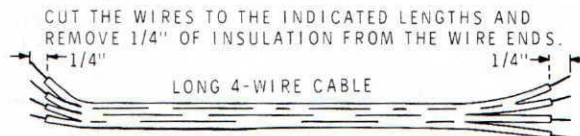
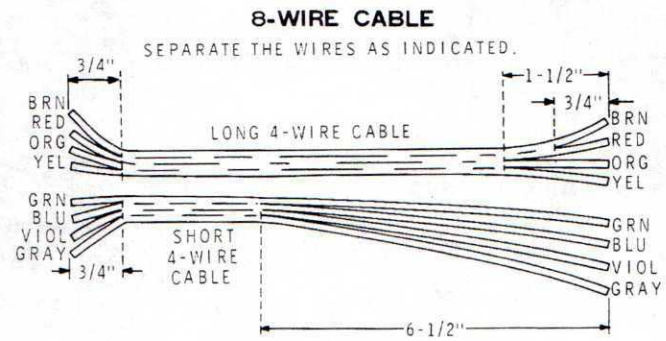

Detail 2-8B

Refer to Pictorial 2-9 (fold-out from Page 15) and position the display circuit board near the main circuit board. Then connect the free wire ends of the short 4-wire cable to the display circuit board as follows:

- 1) Gray wire to hole H (S-1).
- 1) Blue wire to hole F (S-1).
- 1) Green wire to hole E (S-1).
- 1) Violet wire to hole D (S-1).
- 2) Connect the free wire ends of the long 4-wire cable to the display circuit board as follows:
 - 2) Yellow wire to hole G (S-1).
 - 2) Orange wire to hole C (S-1).
 - 2) Red wire to hole B (S-1).
 - 2) Brown wire to hole A (S-1).

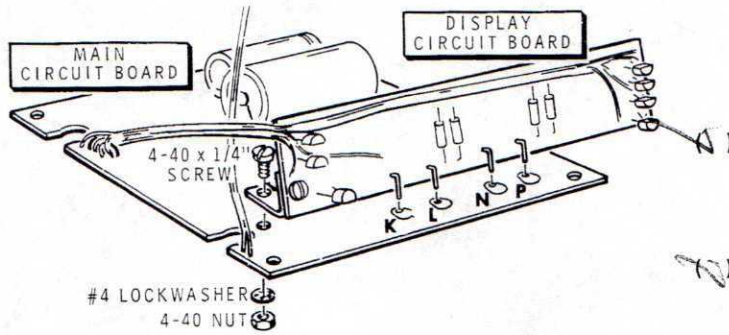

Detail 2-9A

7) Refer to Detail 2-9A and mount the display circuit board to the main circuit board. (Be sure the cables are positioned as shown.) First, insert the four bare wires at K, L, N, and P into their corresponding holes; then install a 4-40 x 1/4" screw, a #4 lockwasher, and a 4-40 nut as shown. Next, solder the bare wires at K, L, N, and P to the foil and cut off the excess lead lengths. (Make sure the display circuit board is parallel to the main circuit board. That is, the display circuit board should be sitting on the main circuit board or be at a uniform height above the main circuit board.)

7) Refer to Pictorial 2-9 and route the brown and red wire pair coming from holes R and S in the main circuit board behind the display circuit board. Then connect the brown wire to hole R (S-1) and the red wire to hole S (S-1) in the display circuit board.

Connect the wires from the foil side of the circuit board. Tug lightly on the wires to be sure they are soldered.

Connect the blue wire coming from hole J in the main circuit board to hole J in the display circuit board (S-1).

Refer to Detail 2-9B and install the neon lamp at V201 on the main circuit board. Mount it 3/8" above the circuit board, solder the leads to the foil, and cut off the excess lead lengths.

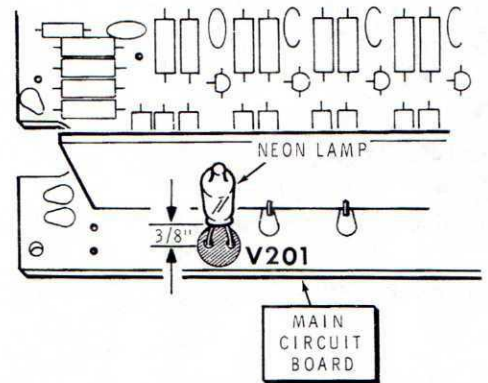

Detail 2-9B

Temporarily set aside the circuit board assembly.

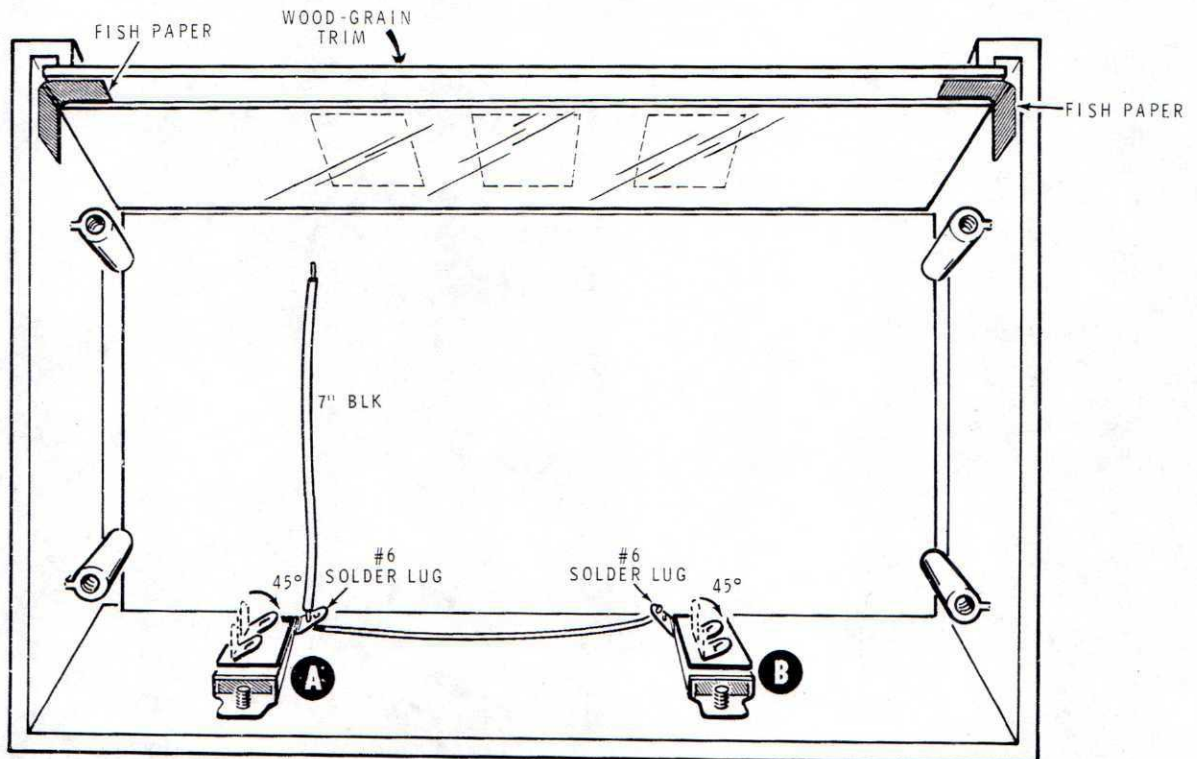

PICTORIAL 3-1

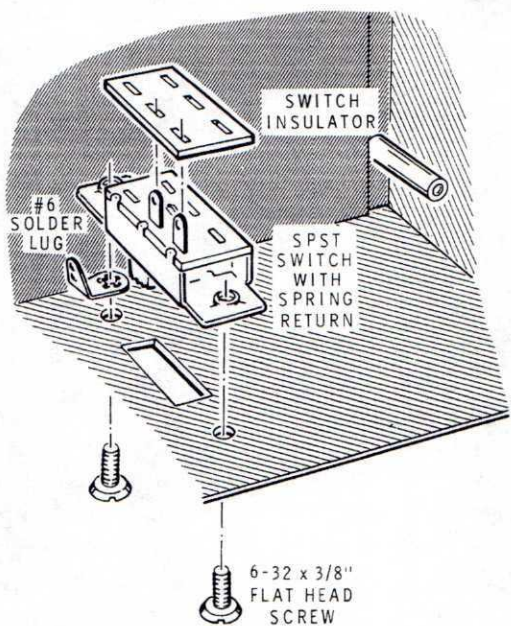

Detail 3-1A

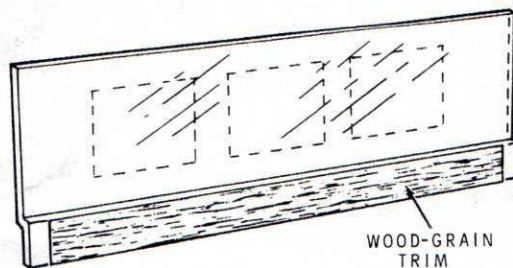

Detail 3-1B

- 1) Refer to Detail 3-1B, remove the narrow wood-grain trim piece from the protective paper backing, center the trim between the sides of the window, and apply it as shown.
- 2) Locate the 5-1/2" x 1-7/8" fish paper, refer to Detail 3-1C, and cut a 1/4" wide strip from one end as shown. Then cut the strip in half.
- 3) Cut a 1" wide strip from the fish paper as shown. Set this 1" wide strip and the remaining large piece of fish paper aside. They will be used later.

CABINET TOP

Refer to Pictorial 3-1 for the following steps.

In the following steps, you will install parts in the cabinet top.

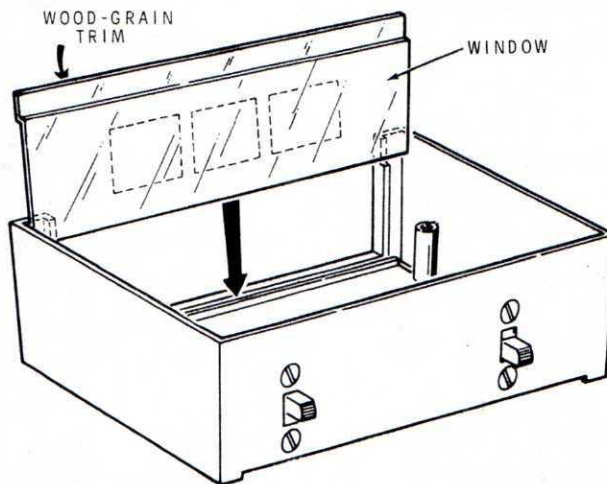

Detail 3-1D

- 1) Refer to Detail 3-1A and install an SPST switch with spring return at B. (Operate the switch to make sure it is a spring-return switch.) Use two 6-32 x 3/8" flat head screws and a #6 solder lug, and be sure the switch lugs and solder lug are positioned as shown.
- 2) Slide a switch insulator over the switch lugs and bend the lugs as shown in the Pictorial.
- 3) As before, mount an SPST switch (without spring return) at A. Use two 6-32 x 3/8" flat head screws and a #6 solder lug. Be sure the switch lugs are positioned as shown. Then slide a switch insulator over the switch lugs and bend the lugs.
- 4) Prepare a 7" length of black wire by removing 3-1/4" of insulation from one end and 1/4" of insulation from the other end.
- 5) Pass the 3-1/4" bared end through the solder lug at A to the solder lug at B. Solder this wire to both lugs. The other end will be connected later.

- 1) Refer to Detail 3-1D and mount the window. Remove the protective paper backing from the two 1/4" wide strips of fish paper and apply them to the window and cabinet top as shown in Pictorial 3-1 to hold the window in place.
- 2) Set the cabinet top aside temporarily.

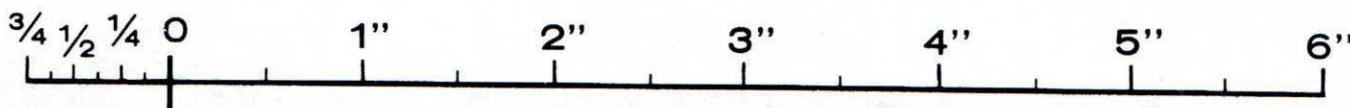

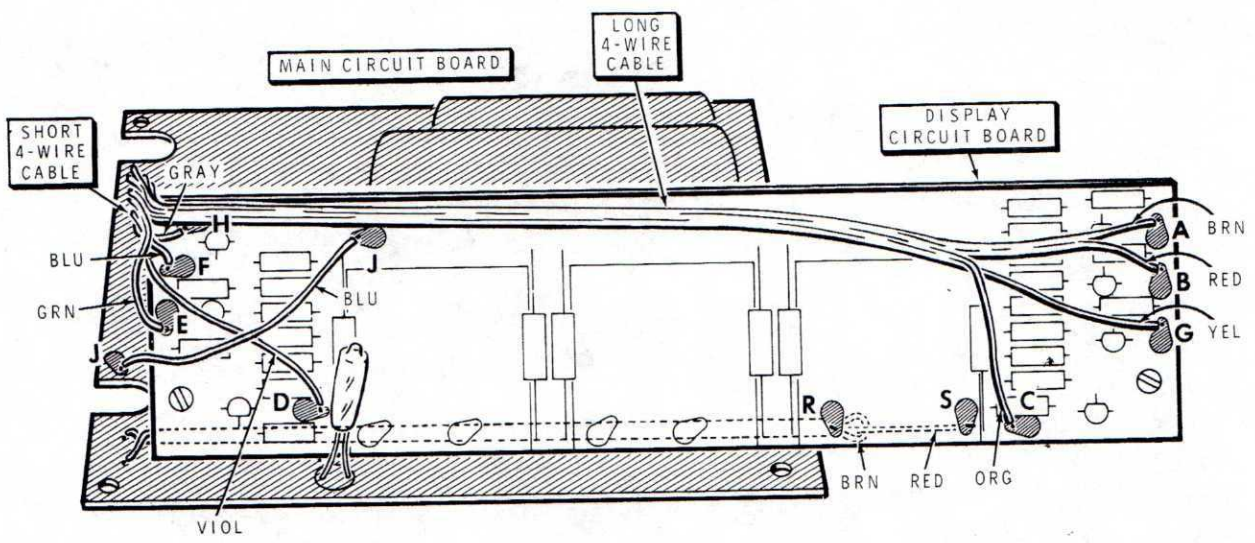

PICTORIAL 2-9

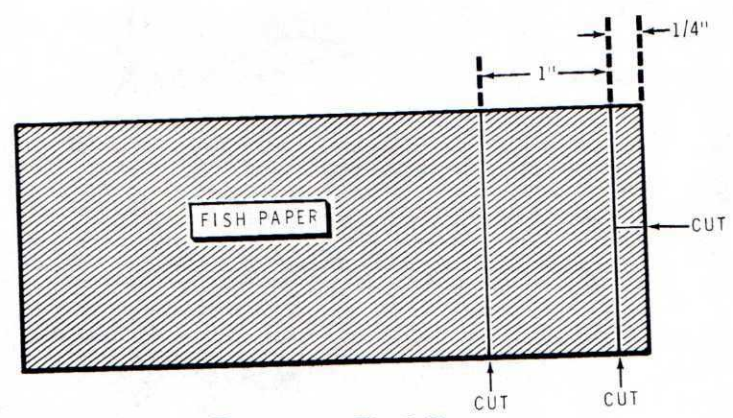

Detail 3-1C

ain
ter
y it

tail
as

Set
fish



move
wide
v and
d the

6"

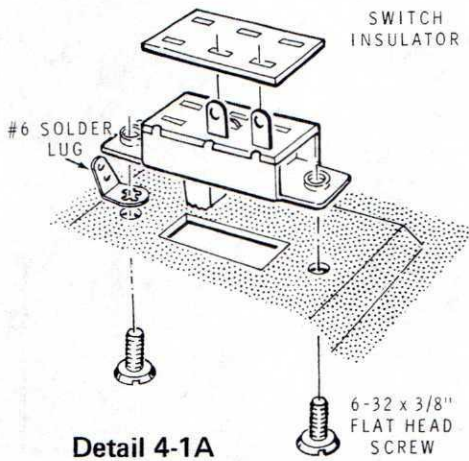

Detail 4-1A

CABINET BOTTOM

Refer to Pictorial 4-1 for the following steps.

In the following steps you will install parts in the cabinet bottom.

- 1) Refer to Detail 4-1A and mount an SPST switch with spring return at C. Use two 6-32 x 3/8" flat head screws and a #6 solder lug. Be sure the switch lugs and solder lug are positioned as shown.
- 2) In a similar manner, mount another #6 solder lug and SPST switch with spring return at D.
- 3) Mount a DPDT switch and a #6 solder lug at E. Use two 6-32 x 3/8" flat head screws.
- 4) Mount a DPDT switch and a #6 solder lug at F. Use two 6-32 x 3/8" flat head screws.
- 5) Install switch insulators on switches C, D, E, and F; and bend the lugs to 45° as shown.
- 6) Prepare a 5" length of black wire by removing 3" of insulation from one end and 1/4" of insulation from the other end.
- 7) Insert the 3" bared end through the top hole of each of the four solder lugs, starting with the solder lug at C.
- 8) Solder this wire to solder lug F, and then to the three other lugs. The other end of the wire will be connected later; route it as shown.
- 9) Refer to Detail 4-1B and install the speaker as shown. Use two speaker clamps and two 2-32 x 1/4" self-tapping screws. Do not overtighten the screws.
- 10) Remove the protective backing from the 1" x 1" piece

of fish paper. Center this paper over the back of the speaker and press the adhesive side against the speaker as shown in Detail 4-1B.

1) Refer to Detail 4-1C and mount the transformer. Be sure the wires are as shown. Use a 6-32 x 3/8" black screw, a #6 flat washer, a #6 lockwasher, and a 6-32 nut at G. Use a 6-32 x 3/8" black screw, a #6 flat washer, two #6 lockwashers, a terminal strip, and a 6-32 nut at H.

2) Refer to inset drawing #1 on Pictorial 4-1 and prepare the end of the line cord.

3) Twist the bare wire strands together and melt a small amount of solder on the strands to hold them together.

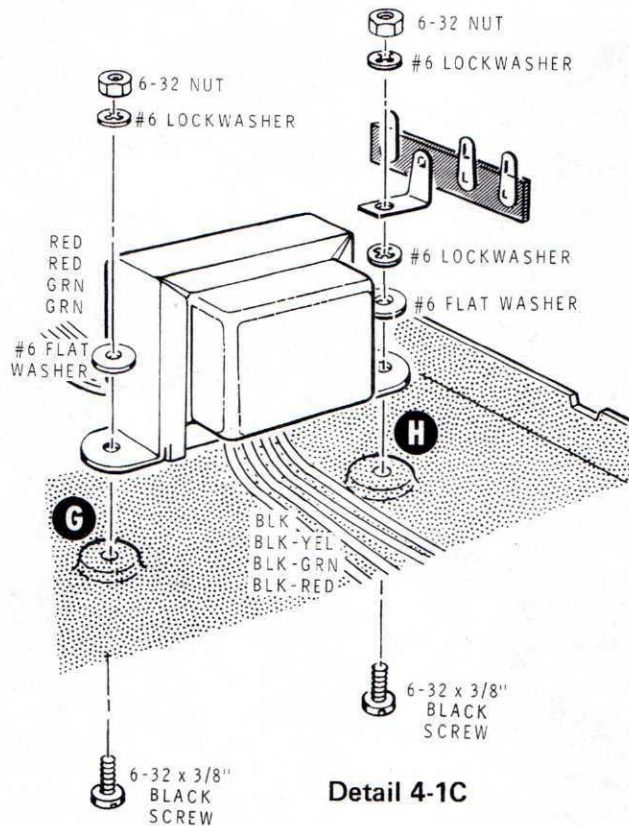

Detail 4-1C

NOTES:

1. In some of the following steps you will be directed to "make a mechanically secure connection." Do this by inserting the wire through a lug or terminal, or wrapping it around the lug or terminal, or both, before soldering. See inset drawing #2 on the Pictorial.
2. The line cord has one of its outer wires marked with a rib in the insulation along its edge. The other wire is smooth. It is important that you connect the smooth wire as indicated.

- ✓) Connect the smooth line cord wire to lug 1 of terminal strip H (NS). Make a mechanically secure connection.
- ✓) Connect the ribbed line cord wire to lug 2 of terminal strip H (NS). Make a mechanically secure connection.
- ✓) Refer to inset drawing #3 on the Pictorial and slide the sleeving over the 3/16-ampere slow-blow fuse as shown.
- ✓) Connect the fuse from lug 1 (S-2) to lug 3 (NS) of terminal strip H. Make mechanically secure connections and position the fuse as close to the terminal strip as possible.

ALTERNATE LINE VOLTAGE WIRING

Two sets of line voltage wiring instructions are given below, one for 120 VAC line voltage and the other for 240 VAC line voltage. In the U.S.A., 120 VAC is most often used, while in foreign countries 240 VAC is more common. USE ONLY THE INSTRUCTIONS THAT AGREE WITH THE LINE VOLTAGE IN YOUR AREA.

120 VAC WIRING

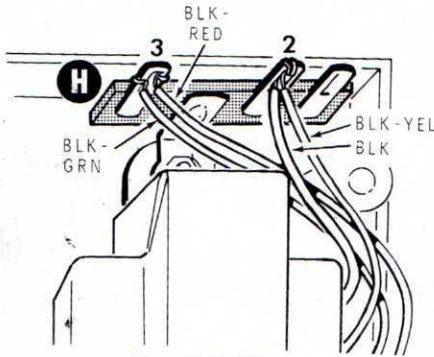

Detail 4-1D

120 VAC Wiring

Refer to Detail 4-1D for the following steps. Be sure to make mechanically secure connections.

- ✓) Connect the black-red transformer lead to lug 3 of terminal strip H (NS).
- ✓) Connect the black-green transformer lead to lug 3 of terminal strip H (S-3).
- ✓) Connect the black-yellow transformer lead to lug 2 of terminal strip H (NS).
- ✓) Connect the black transformer lead to lug 2 of terminal strip H (S-3).

240 VAC WIRING

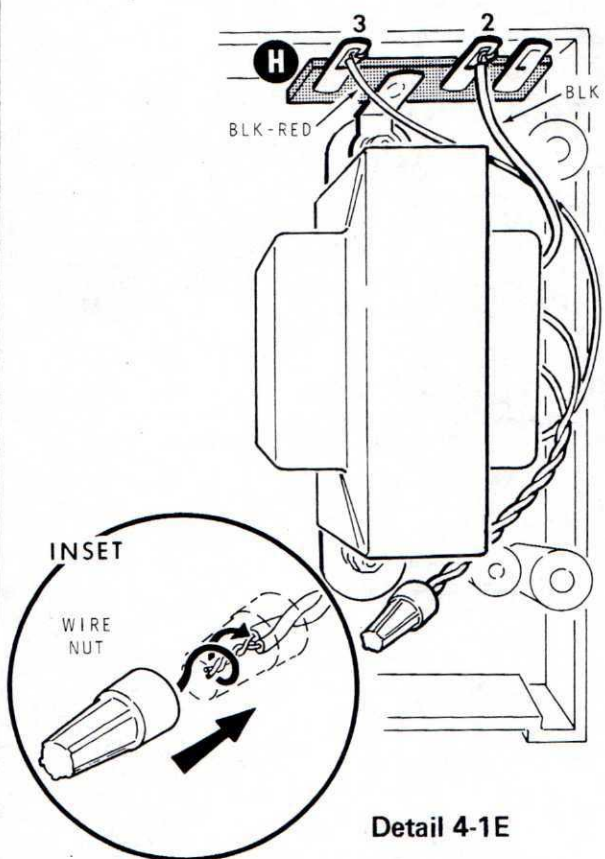

Detail 4-1E

240 VAC Wiring

Refer to Detail 4-1E for the following steps.

- () Connect the black-red transformer lead to lug 3 of terminal strip H (S-2).
- () Connect the black transformer lead to lug 2 of terminal strip H (S-2).
- () Twist the ends of the black-green and black-yellow transformer leads together in a clockwise direction. Then twist the wire nut onto the wires in a clockwise direction. Refer to the inset drawing.

OTHER WIRING

- () Locate the remaining red and brown wire pair, cut it to a length of 9", and prepare the ends as shown in Detail 4-1F.

Connect end B of the red and brown wires as follows:

- ✓) Red wire to lug 1 of switch D (NS).

- 7) Brown wire to lug 1 of switch C (NS).
- 6) From the remaining miscellaneous lengths of wire, prepare the following wires:
1" red
3" brown
- 7) Connect the 1" red wire from lug 1 of switch D (S-2) to lug 6 of switch E (S-1).
- 7) Connect the 3" brown wire from lug 1 of switch C (S-2) to lug 1 of switch F (S-1).
- 7) Locate the 1" wide length of fish paper. Then remove its paper backing and apply the fish paper to the indicated corner of the power transformer as shown in Pictorial 4-1. See inset drawing #4.

- 6) Green wire to lug 5 of switch E (S-1).
- 6) Yellow wire to lug 2 of switch D (S-1).
- 6) Orange wire to lug 2 of switch C (S-1).
- 7) Connect the orange wire coming from hole AS to lug 5 of switch F (NS).
- 7) Prepare the following wires:
1" orange
1" violet
- 7) Connect the 1" orange wire from lug 2 of switch E (S-1) to lug 5 of switch F (S-2).
- 7) Connect the 1" violet wire from lug 1 of switch E (S-1) to lug 6 of switch F (S-2).
- 7) Connect the violet wire coming from hole U to lug 1 of the speaker (S-1).
- 7) Connect the gray wire coming from hole AJ to lug 2 of the speaker (S-1).

Refer to Pictorial 5-1 for the following steps.

NOTE: In the following steps, you will connect wires coming from the main circuit board to parts mounted on the cabinet bottom.

Connect the free ends of the 5-wire cable as follows:

- 7) Blue wire to lug 2 of switch F (S-1).
- 7) Violet wire to lug 6 of switch F (NS).

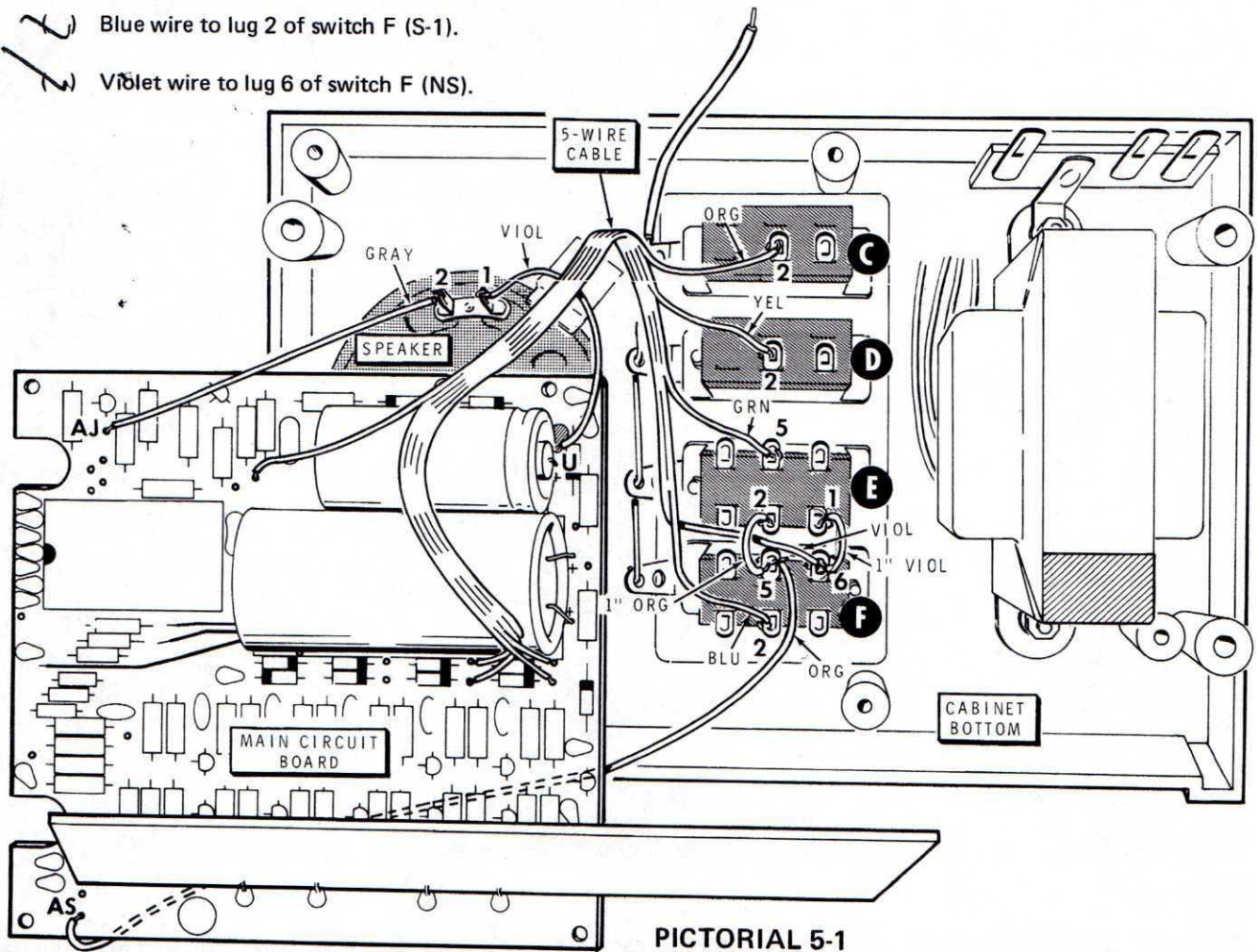

PICTORIAL 5-1

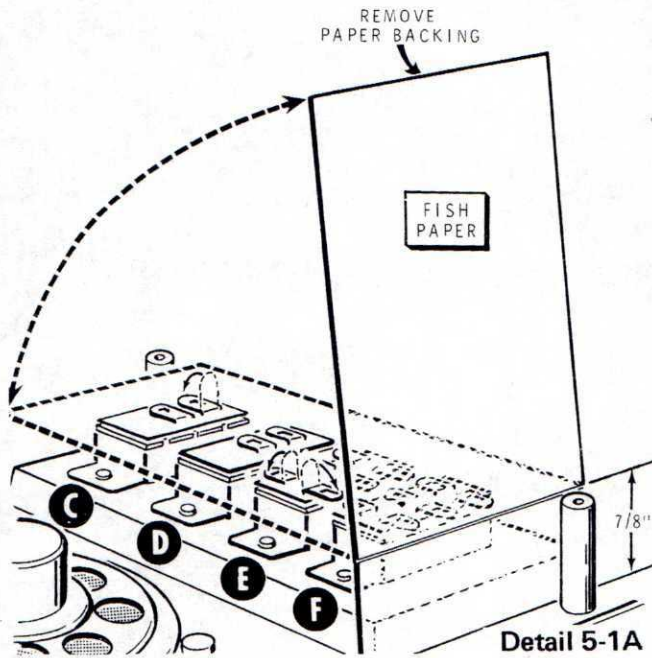

- ✓) In a similar manner, connect the free end of the 7" black wire coming from the solder lug at switch A to the 1200 μ F capacitor lead. Solder the connection.
- ✓) Remove the paper backing from the fuse label. Then position the label onto the inside of the cabinet top as shown, cover the label with the paper backing, and press the label in place. This will prevent any ink from smearing.
- ✓) Carefully peel away the backing paper from the blue and white identification label. Then press the label onto the inside of the cabinet top. Be sure to refer to the numbers on this label in any communications you have with the Heath Company about this kit.

Connect the remaining free wire ends to the switches in the cabinet top as follows:

Blue and green wire pair.

- ✓) Blue wire coming from hole AD to lug 1 of switch A (S-1).

- ✓) Green wire coming from hole AC to lug 2 of switch B (S-1).

Red and brown wire pair.

- ✓) Red wire to lug 2 of switch A (NS).

- ✓) Brown wire to lug 1 of switch B (NS).

Violet and gray wire pair.

- ✓) Violet wire coming from hole AB to lug 2 of switch A (S-2).

- ✓) Gray wire coming from hole AA to lug 1 of switch B (S-2).

This completes the wiring of your Heathkit Electronic Clock. Carefully inspect all connections for loose wires or unsoldered connections. Remove any wire clippings or solder splashes. Then continue with the assembly steps.

NOTE: The integrated circuit (IC) can be damaged by static voltage. To prevent this, be sure you have no static voltage built up on your person or clothing before you handle the IC.

- ✓) Locate the MK5017AA integrated circuit (#443-601). Position the dot end of the IC over the half dot screened on the main circuit board. Then insert the IC leads into the IC connectors. (See inset drawing #3.) Be sure each IC lead is properly inserted. **DO NOT** solder the IC to the connectors.

- ✓) Refer to Detail 5-1A and bend the lugs of switches C, D, E, and F down against the switch insulators as shown.
- ✓) Bend the remaining length of fish paper 7/8" from one end, remove the protective paper backing, and cover switches C, D, E, and F as shown.

Refer to Pictorial 5-2 (fold-out from Page 23) for the following steps.

- ✓) Mount the circuit boards to the cabinet bottom. Use five 2-32 x 1/4" self-tapping screws. Do not overtighten the screws.

Connect the remaining transformer leads to the main circuit board as follows:

- ✓) Either red wire to the connector pin at hole X (S-1). See inset drawing #1.
- ✓) Other red wire to the connector pin at hole Y (S-1).
- ✓) Either green wire to the connector pin at hole Z (S-1).
- ✓) Other green wire to the connector pin at hole T (S-1) NOTE: Be sure the connector pin is not touching the 1200 μ F capacitor.

- ✓) Locate the fuse label and record the fuse rating on the label (3/16 ampere).

- ✓) Refer to inset drawing #2 and connect the free end of the black wire coming from the solder lug at switch C to the lead of the 1200 μ F capacitor as shown. Solder the connection.

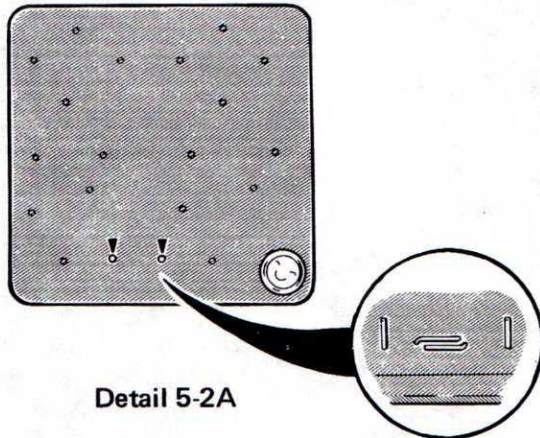

Detail 5-2A

- 7) Refer to Detail 5-2A and position your display tubes as shown. If your display tubes have the two pins marked with a **!**, bend these two pins toward each other as shown in the inset drawing. They will not be used. If your display tubes do not have these pins, proceed to the next step.

NOTE: When you install the display tubes in the following steps, support the rear of the readout circuit board as shown to prevent breaking the circuit board.

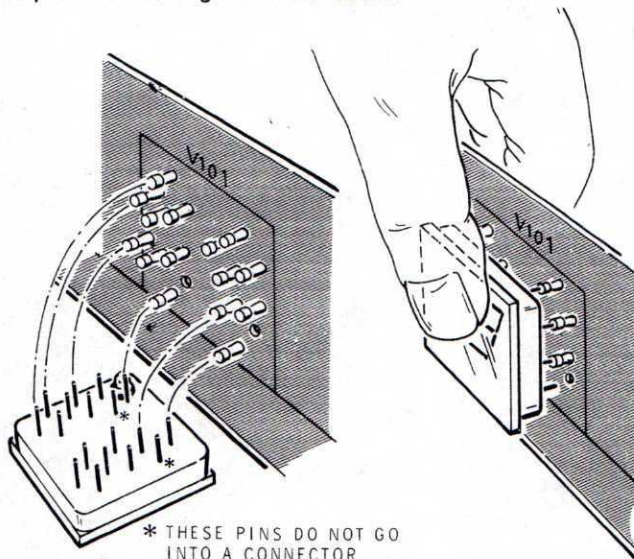

Detail 5-2B

- 7) Refer to Detail 5-2B and install a display tube at V101. Examine the pins to make sure they are straight (except as explained in the previous step) before you install the tube. As you install each tube, watch the leads to make sure each one goes into its connector, if it has one. **NOTE:** Not all the leads go into connectors.
- 7) Likewise, install display tubes at V102 and V103.

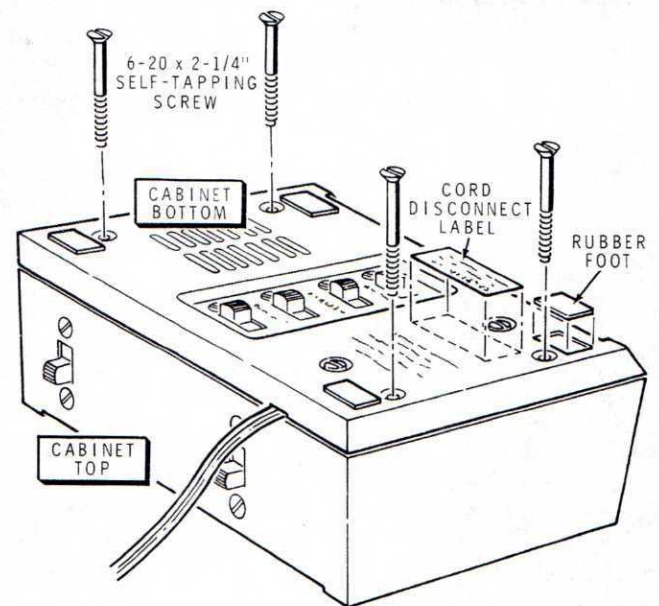

PICTORIAL 5-3

Refer to Pictorial 5-3 for the following steps.

NOTE: In the following step, be sure you do not pinch any wires between the cabinet top and cabinet bottom.

- 7) Position the cabinet top over the cabinet bottom. Then lower the top straight down onto the bottom. (This will keep the window from being scratched by the corners of the display tubes.) **NOTE:** Be sure the line cord knot is positioned inside the cabinet and the line cord is in the channel provided for it in the cabinet.
- 7) Fasten the cabinet top and bottom together with four 6-20 x 2-1/4" self-tapping screws.
- 7) Remove the paper backing from the rubber feet and install the feet at the four corners as shown.
- 7) Remove the paper backing from the cord disconnect label and press the label into position as shown.

DECORATING

- () Remove the backing paper from the Heathkit label and apply it to the front of the cabinet as shown in Pictorial 6-1.
- () The use of the remaining piece of wood-grain trim is optional. Apply it to the cabinet top if you so desire.

This completes the "Step-by-Step Assembly."

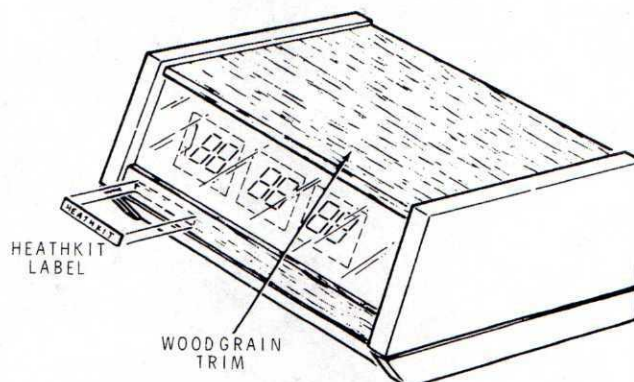

PICTORIAL 6-1

INITIAL TESTS

Refer to Figure 2 (fold-out from Page 23) to identify the function of each switch.

NOTE: If you do not obtain the proper results in any of the following steps, unplug the line cord plug and proceed to the "In Case of Difficulty" section on Page 22.

- () Set the six switches to the positions shown.
- () Plug the line cord plug into an AC outlet. Each of the six display digits should indicate an eight.
- () Push the TIME HOLD switch to the right and back again. The display should now indicate 12:00:00 or 00:00:00 and start keeping time.
- () Push the Alarm Set switch to the right. The display should now indicate 12:00:00 or 00:00:00 and the AM-PM lamp should be on.
- () Push and hold the HOURS SET-AHEAD switch to the right. The HOURS DISPLAY will now advance one digit each half second. The AM-PM lamp will turn on and off each six seconds.
- () Release the HOURS SET-AHEAD switch.
- () Push and hold the MINUTES SET-AHEAD switch to the right. The MINUTES DISPLAY will now advance one digit each half second.
- () Push both the MINUTES SET-AHEAD switch and the HOURS SET-AHEAD switch to the right. The tens of minutes will now advance one digit each half second.
- () Push the MINUTES and HOURS SET-AHEAD switches as necessary until the MINUTES DISPLAY indicates 45 minutes; then quickly release the MINUTES SET-AHEAD switch.
- () Continue holding the HOURS SET-AHEAD switch until the HOURS DISPLAY indicates 6 and the AM-PM lamp is on (indicating AM). Then quickly release the switch.
- () Push the ALARM SET switch to the left.
- () Push the ALARM ON-OFF switch to the ON (down) position.
- () Push the TIME HOLD switch to the right.
- () Push both the HOURS SET-AHEAD switch and the MINUTES SET-AHEAD switch to the right as necessary until the MINUTES DISPLAY indicates 44 minutes. Then quickly release the MINUTES SET-AHEAD switch.
- () Continue holding the HOURS SET-AHEAD switch until the HOURS DISPLAY indicates 6 and the AM-PM lamp is on (indicating AM). Then quickly release the switch.
- () Push the TIME HOLD switch to the left. The clock should now start keeping time and in approximately one minute the alarm should sound.
- () When the alarm sounds, push the SNOOZE ALARM switch down (to reset the snooze alarm) and release the switch. In approximately seven minutes, the alarm should sound again.
- () Push the ALARM ON-OFF switch up to the OFF position.

This completes the "Initial Tests."

OPERATION

Figure 2 (fold-out from Page 23) points out the switches and displays of your Clock. These switches and displays are further described below.

1. **ALARM ON-OFF SWITCH** — Turns the alarm on and off. Down is on. NOTE: After the alarm sounds, if you wish, you may turn the alarm off and immediately return the switch to the ON position. The alarm will then sound 24 hours later.
 2. **SNOOZE ALARM SWITCH** — Resets the alarm to go off seven minutes later.
 3. **HOURS SET-AHEAD SWITCH** — Advances the HOURS DISPLAY one hour each half second.
 4. **MINUTES SET-AHEAD SWITCH** — Advances the MINUTES DISPLAY one minute each half second.
- 3 and 4. When used together, they advance the MINUTES DISPLAY ten minutes each half second.
5. **ALARM SET SWITCH** — Allows you to set the alarm using the HOURS and MINUTES SET-AHEAD switches. Also allows the display to indicate the time for which the alarm is set. (Time continues to be kept even though it is not displayed when this switch is being used.)
 6. **TIME HOLD SWITCH** — Allows you to set the Clock ahead to the desired time, using the HOURS and MINUTES SET-AHEAD switches, and then start the clock when the desired time arrives.
 7. **AM-PM LAMP** — Indicates AM when on and PM when off; only when setting the alarm or the time. The Lamp is not on during normal operation.

- 8, 9, and 10. **HOURS, MINUTES, and SECONDS DISPLAY** — Indicate the time or the time that the alarm is set for. Indicates all 8's when first plugged in or when power has been interrupted for several seconds.

TO SET THE TIME:

1. Push the TIME HOLD switch to the right.
2. Push the MINUTES SET-AHEAD and HOURS SET-AHEAD switches (separately or together) as necessary to advance the display to a desired time. Be sure the AM-PM lamp is on or off as desired — on is AM; off is PM.
3. Watch another clock. When the time gets to the time on the display, push the TIME HOLD switch to the left.

TO SET THE ALARM:

1. Push the ALARM-SET switch to the right. (The clock will continue to keep time, even though the display is stationary.)
2. Push the MINUTES SET-AHEAD and HOURS SET-AHEAD switches (separately or together) as necessary to advance the display to a desired time. Be sure the AM-PM lamp is on or off as desired — on is AM; off is PM.
3. Push the ALARM-SET switch to the left.
4. Push the ALARM ON-OFF switch down to the ON position.

FOR DAYLIGHT SAVINGS TIME:

1. Push the HOURS SET-AHEAD switch to the right and advance the HOURS DISPLAY to the desired hour. NOTE: To go back an hour, advance the display 23 hours.

IN CASE OF DIFFICULTY

This section of the Manual is divided into two parts. The first part, titled "General Troubleshooting Information," describes what to do about the difficulties that may occur right after your Clock is assembled.

The second part, titled "Troubleshooting Chart," is provided to assist you in servicing the Clock if the "General Troubleshooting Information" fails to clear up the problem, or if difficulties occur after your Clock has been in use for some time. The "Troubleshooting Chart" lists a number of possible difficulties that could arise along with several possible solutions to those difficulties.

Try to analyze the symptoms of any problem you might have before starting any troubleshooting procedure. This can usually be accomplished by trying the various functions of your Clock to determine abnormal operations. A review of the "Operation" section above may help your analysis.

NOTE: Refer to the "Circuit Board X-Ray Views" on Pages 28 and 29 for the physical location of parts on the circuit boards.

GENERAL TROUBLESHOOTING INFORMATION

1. Check all the wires that are connected between the two circuit boards and between the circuit boards and other parts. Trace each wire in colored pencil on the Pictorial as it is checked. Make sure these wires are connected to the proper points and are properly soldered. Someone who is not familiar with the unit may notice something you have consistently overlooked.
2. Be sure the IC is seated properly in its socket.
3. About 90% of the kits that are returned for repair do not function properly because of poor connections and soldering. Therefore, many troubles can be located by a careful inspection of connections to make sure they are soldered as described in the "Soldering" section of the "Kit Builders Guide." Reheat any doubtful connections.
4. Closely examine each circuit board foil in a good light to see that no solder bridges exist between adjacent connections. If available, a magnifying glass would be helpful for this purpose. Remove any solder bridges by holding a clean, hot soldering iron tip between the two points that are bridged until the excess solder flows down onto the tip. Compare your foil pattern against the "X-Ray Views" on Pages 28 and 29.
5. Be sure each transistor is in its proper location (correct part number and/or type number). Be sure that each transistor lead is in the right hole and has a good solder connection to the foil.
6. Check the integrated circuit for proper positioning. (Be sure the dot or notched end of the IC is over the half dot printed on the circuit board.)
7. Check each capacitor value. Be sure that a capacitor of correct value is installed at each capacitor location. Check each electrolytic capacitor to be sure the lead near the positive (+) marking is at the correct position.
8. Check each resistor value carefully. It would be easy, for example, to install a 2200 Ω (red-red-red) resistor where a 22 k Ω (red-red-orange) resistor is called for. A resistor that is discolored, or cracked, or shows any sign of bulging would indicate that it is damaged and should be replaced. Since damaged resistors are often the result of some other difficulty (such as faulty wiring), you should try to find out what caused the damage before you replace the part.
9. Be sure the correct diode is installed at each diode location, and that the banded end is positioned correctly.
10. Check all component leads connected to the circuit boards. Make sure the leads do not extend through the circuit board and come in contact with other connections or parts.

If you still cannot locate and correct the trouble after the above tests are completed, and if a voltmeter is available, check your Clock's voltages against the voltages shown on the Schematic Diagram (fold-out from Page 31) and in the "Circuit Board Voltage Charts" (Page 30).

NOTE: In an extreme case where you are unable to resolve a difficulty, refer to the "Customer Service" information inside the rear cover of the Manual. Your Warranty is located inside the front cover of the Manual.

WARNING: Hazardous voltages are exposed in the Clock when the cabinet top is removed and the line cord is plugged into the AC outlet. See "Chassis Photograph" on Page 27.

rect
each
ood

ing.
the

of
tion.
lead
tion.

easy,
istor
or. A
any
and
often
ulty
d the

mode
oned

ircuit
h the
other

or the
lable,
on on
n the

olve a
iation
ity is

Clock
ugged
27.

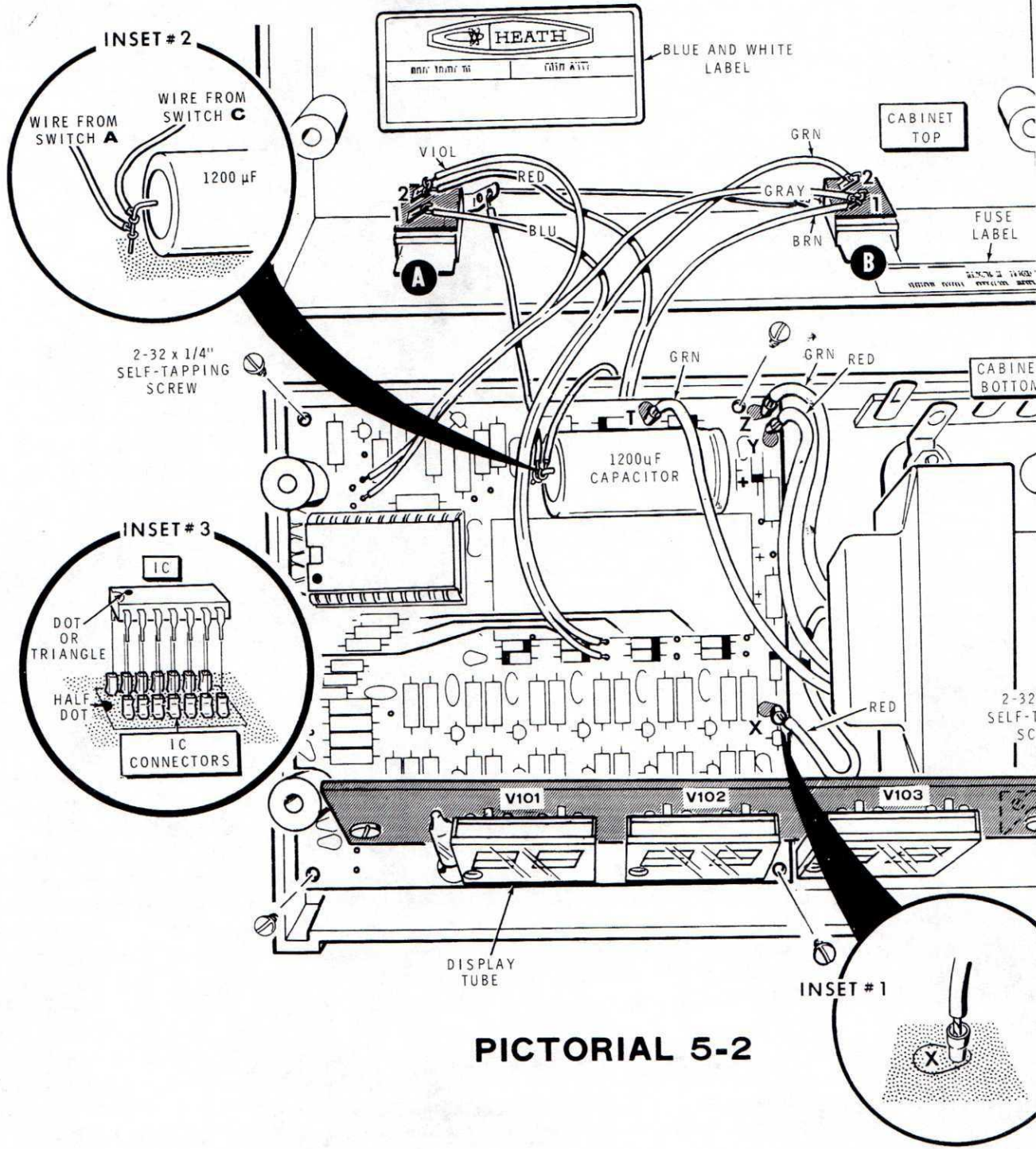

PICTORIAL 5-2

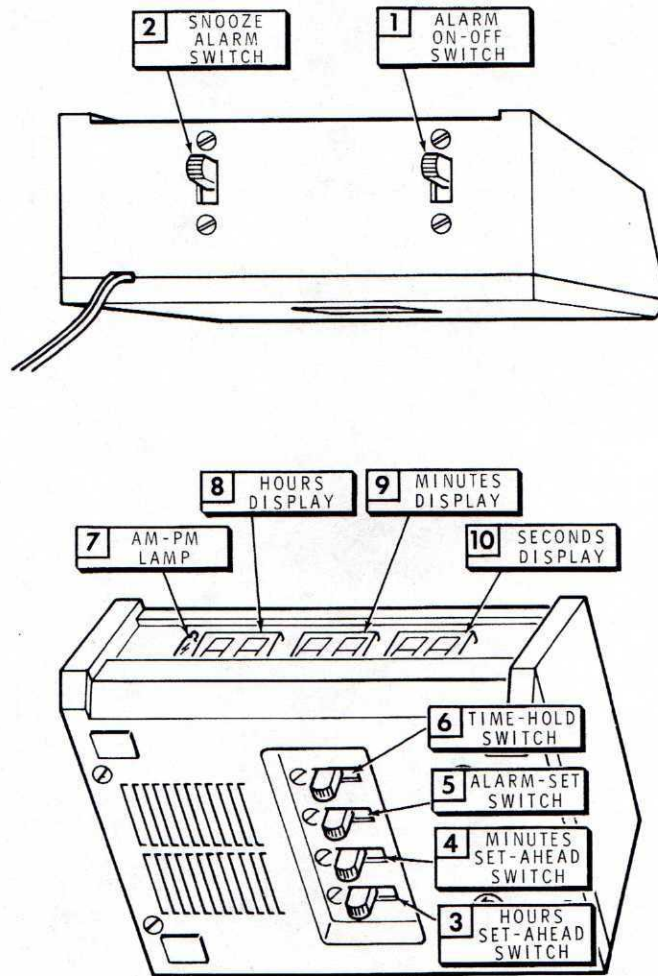
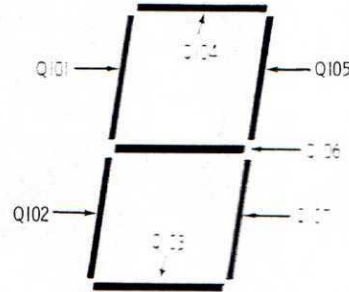

Figure 2

Troubleshooting Chart

This chart lists the condition and possible cause of several malfunctions. If a particular part or parts are mentioned (Q107 for example) as a possible cause, check that part to see that it was installed and/or wired correctly. It is also possible, on rare occasions, for a part to be faulty and require replacement.



CONDITION	POSSIBLE CAUSE
A digit or a segment of digit does not light.	1. Check pins of that display tube.
The same segment of all six digits remains lit or does not turn on.	1. Associated transistor (Q101 through Q107). See above.
One digit does not light or has undesired segment glow.	1. Associated transistors (Q201 through Q212) as follows: V101B - Q211, Q212. V101A - Q209, Q210. V102B - Q207, Q208. V102A - Q205, Q206. V103B - Q203, Q204. V103A - Q201, Q202. 2. Display tube. Interchange tubes to see if tube is bad.
None of the digits light.	1. Diode D201. 2. Fuse F301. 3. Check for +15 volts at BX on circuit board. 4. ZD201. 5. D202. 6. IC201.
One digit lights up much brighter than others.	1. Associated transistor (Q201 through Q212).
Only one digit is turned on.	1. IC201.
Time or alarm cannot be set.	1. Diodes D204 through D211. 2. Switch S301 through S306. 3. IC201.

CONDITION	POSSIBLE CAUSE
Time does not advance.	<ol style="list-style-type: none"> 1. Diode D203. 2. IC201.
Alarm does not work properly.	<ol style="list-style-type: none"> 1. Switch S305 or S306. 2. Diode D208 or D209. 3. Transistor Q214. 4. Speaker SP301. 5. IC201.
AM-PM lamp does not turn on.	<ol style="list-style-type: none"> 1. Lamp is not normally on. See Page 22. 2. Switch S301 or S302. 3. Transistor Q213. 4. V201. 5. Resistors R218, R219, or R220 interchanged.
Clock gains time.	<ol style="list-style-type: none"> 1. 50 Hz jumper wire was installed. See Page 11, left-hand column, step 5.

SPECIFICATIONS

Display	Six full digits.
Format	12 or 24 hour.
Accuracy	Determined by accuracy of power line frequency.
Snooze Alarm	Seven minute intervals.
Power	6.5 watts, 120 VAC or 240 VAC, 50 Hz or 60 Hz.
Dimensions	7" wide x 5" deep x 2-1/2" high.
Weight	3 lbs.

The Heath Company reserves the right to discontinue instruments and to change specifications at any time without incurring any obligation to incorporate new features in instruments previously sold.

CIRCUIT FUNDAMENTALS

The following fundamentals will give you a better understanding of the circuit relationships in your Clock and describe how the circuits work together. Refer to the Schematic Diagram (fold-out from Page 31) while you read the following information.

All the digital logic is performed inside of IC201. The remaining circuitry supplies the DC power and responds to the commands from IC201 to drive the speaker and the display tubes.

Resistor R204 and capacitor C201 are the timing components for the oscillator inside IC201. The oscillator scans (applies a positive driving pulse to first D1, then D2, then D3, etc.) outputs D1 through D6 in rapid succession. At the correct times, positive pulses are applied to the proper pins (9 through 15) of IC201 to turn on the correct digits in the proper display tubes.

Example: Consider the time 08:56:21.

As a positive pulse is applied to D1 (which turns on transistors Q201 and Q202, and applies 230 volts to the anode of tube V103, part A), positive pulses are also applied to pins 13 and 14 of the IC. These pulses at pins 13 and 14 turn on transistors Q105 and Q107, which turn on segments b and c of the display tube, and a one is displayed. The other digits (of V103, V102, and V101) do not light up because they do not have a high enough voltage at their anodes.

The positive pulse is then applied to D2, and part B of tube V103 receives the high anode voltage. At this same time, positive pulses are also applied to pins 9, 11, 12, 14, and 15 of the IC. This turns on segments a, b, g, e, and d, and a two is displayed.

Next, positive pulses are applied to D3 and pins 9, 10, 11, 12, 13, and 15 of the IC, and a six is displayed in part A of V102. The scanning continues through D6 and then starts over. This happens so fast that all six digits appear to be on at once.

Transistor Q213 turns on lamp V201 at the proper time when the alarm or time is being set, and transistor Q214 drives the speaker, SP301.

Diodes D204 through D211 are a diode matrix to keep the DC voltages on their own control lines. (D1 through D6 are the control lines.)

Dual-primary transformer T301 can be wired to operate from either 120 VAC or 240 VAC. Two secondary windings furnish the voltage required by the Clock. Diode D201 forms a half-wave rectifier, and capacitor C203 and resistor R211 filter this voltage that drives the display tubes. Diode D202, resistor R210, and capacitor C204 also are a rectifier and filter circuit, and zener diode ZD201 maintains the proper operating voltage for IC201. Diode D203 is another rectifier and, along with resistors R209 and R208, provides the proper 50 or 60 Hz signal to act as the Clock's reference frequency. Capacitor C202 is a filter capacitor.

CHASSIS PHOTOGRAPH

WARNING: *Boxed in area indicates hazardous voltage location.*

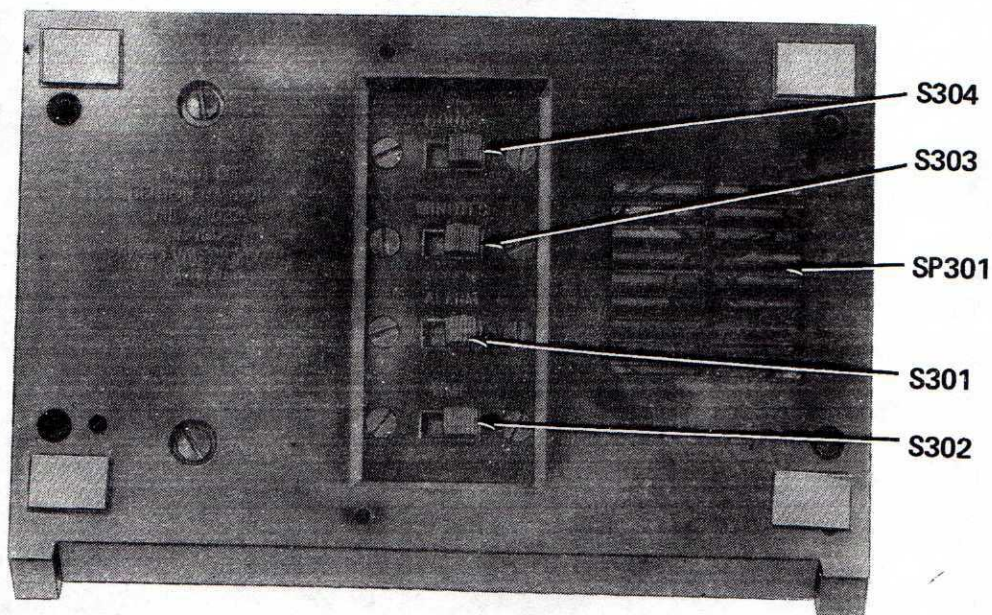
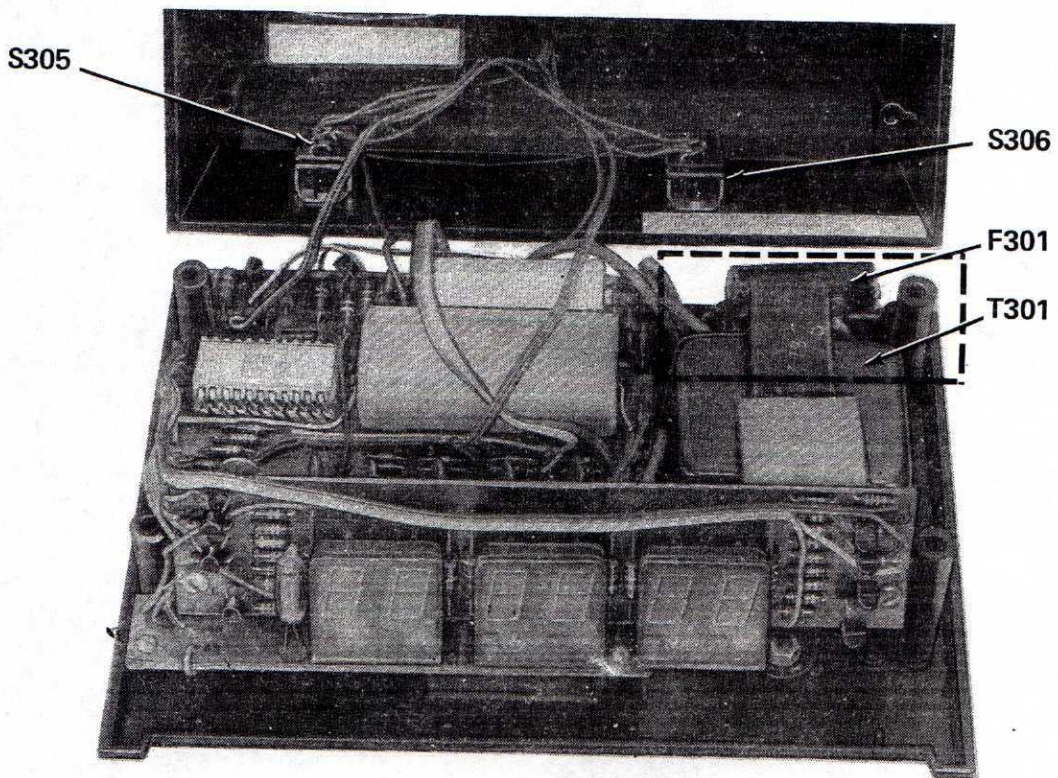

CIRCUIT BOARD X-RAY VIEWS

NOTE: To identify a part shown in one of these Views, so you can order a replacement, proceed in either of the following ways:

1. A. Refer to the place where the part is installed in the Step-by-Step instructions and note the "Description" of the part (for example: 22 k Ω , .05 μ F, or 2N2712).
 - B. Look up this Description in the "Parts List."
2. A. Note the identification number of the part (R-number, C-number, etc.).
 - B. Locate the same identification number (next to the part) on the Schematic. The "Description" of the part will also appear near the part.
 - C. Look up this Description in the "Parts List."

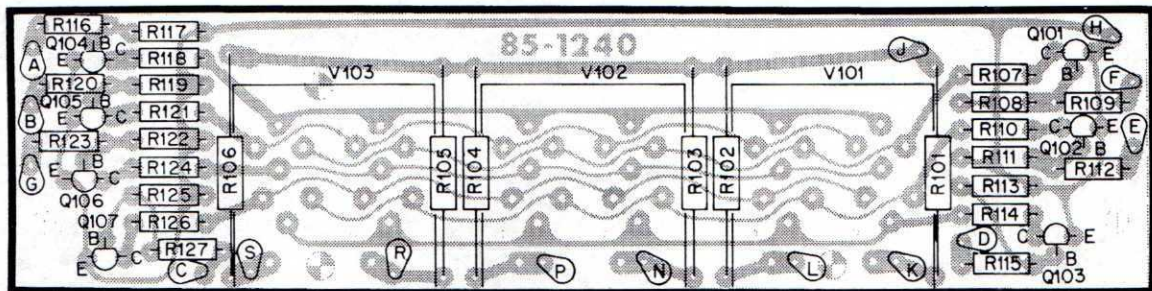

DISPLAY CIRCUIT BOARD
(Viewed from foil side)

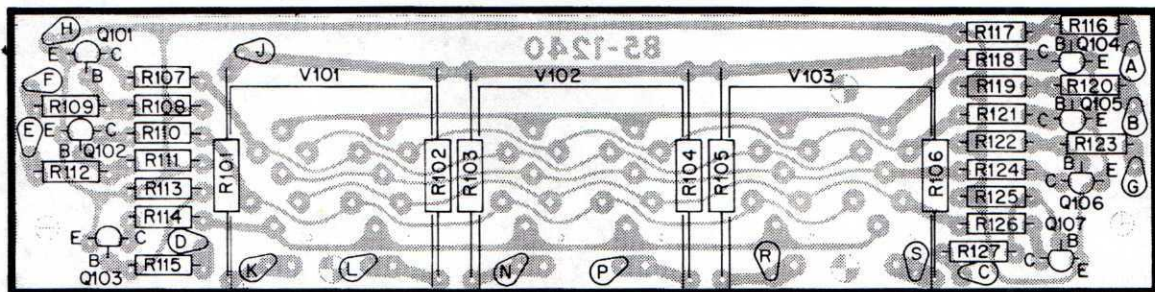

DISPLAY CIRCUIT BOARD
(Viewed from component side)

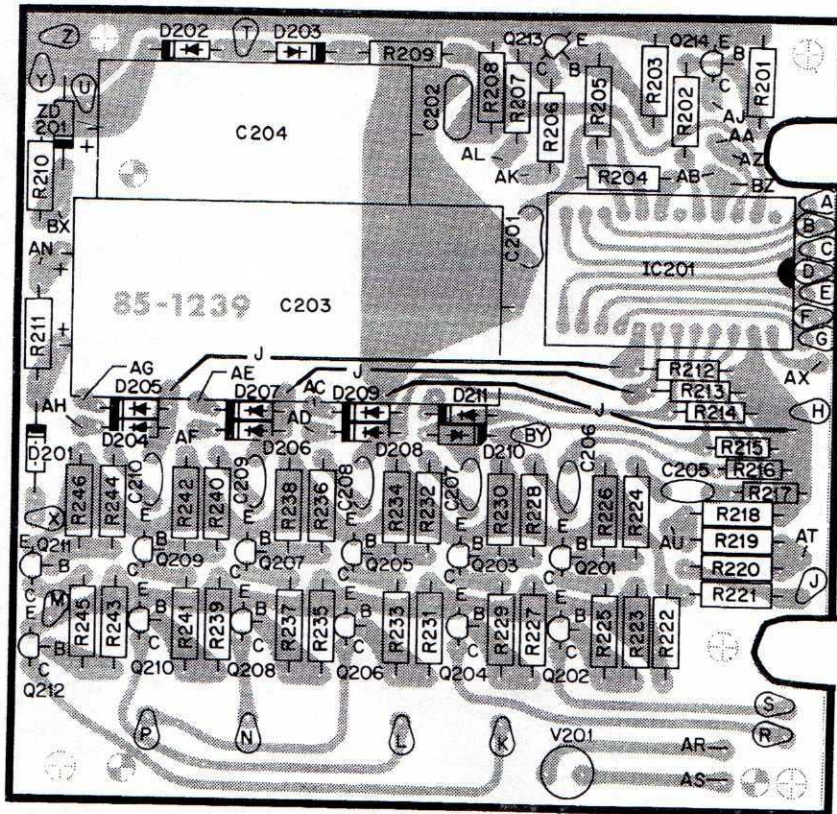

MAIN CIRCUIT BOARD
(Viewed from foil side)

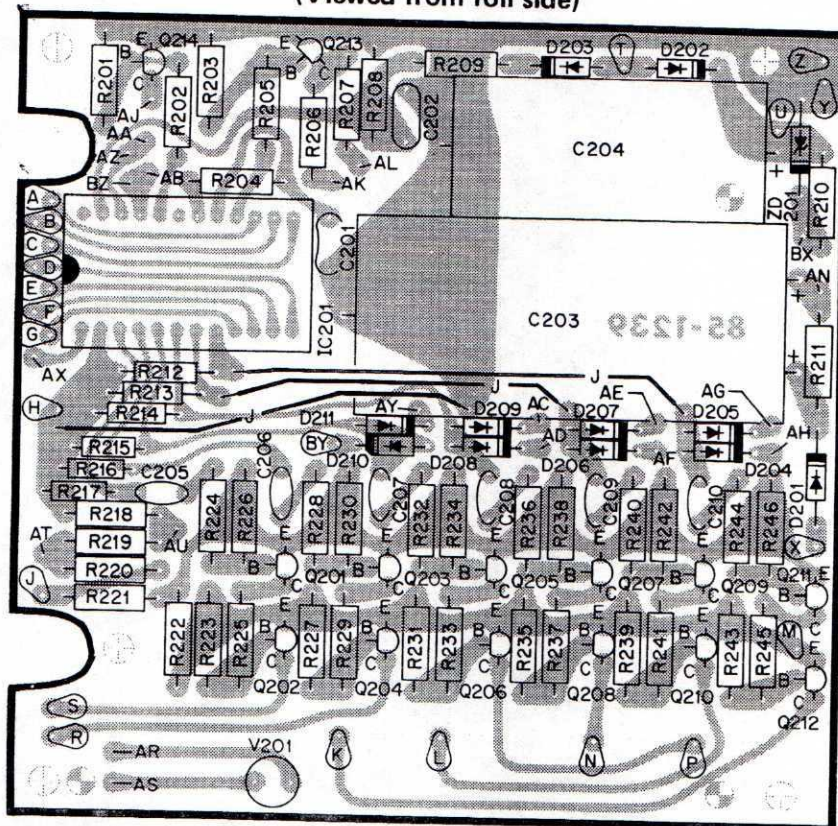

MAIN CIRCUIT BOARD
(Viewed from component side)

CIRCUIT BOARD VOLTAGE CHARTS

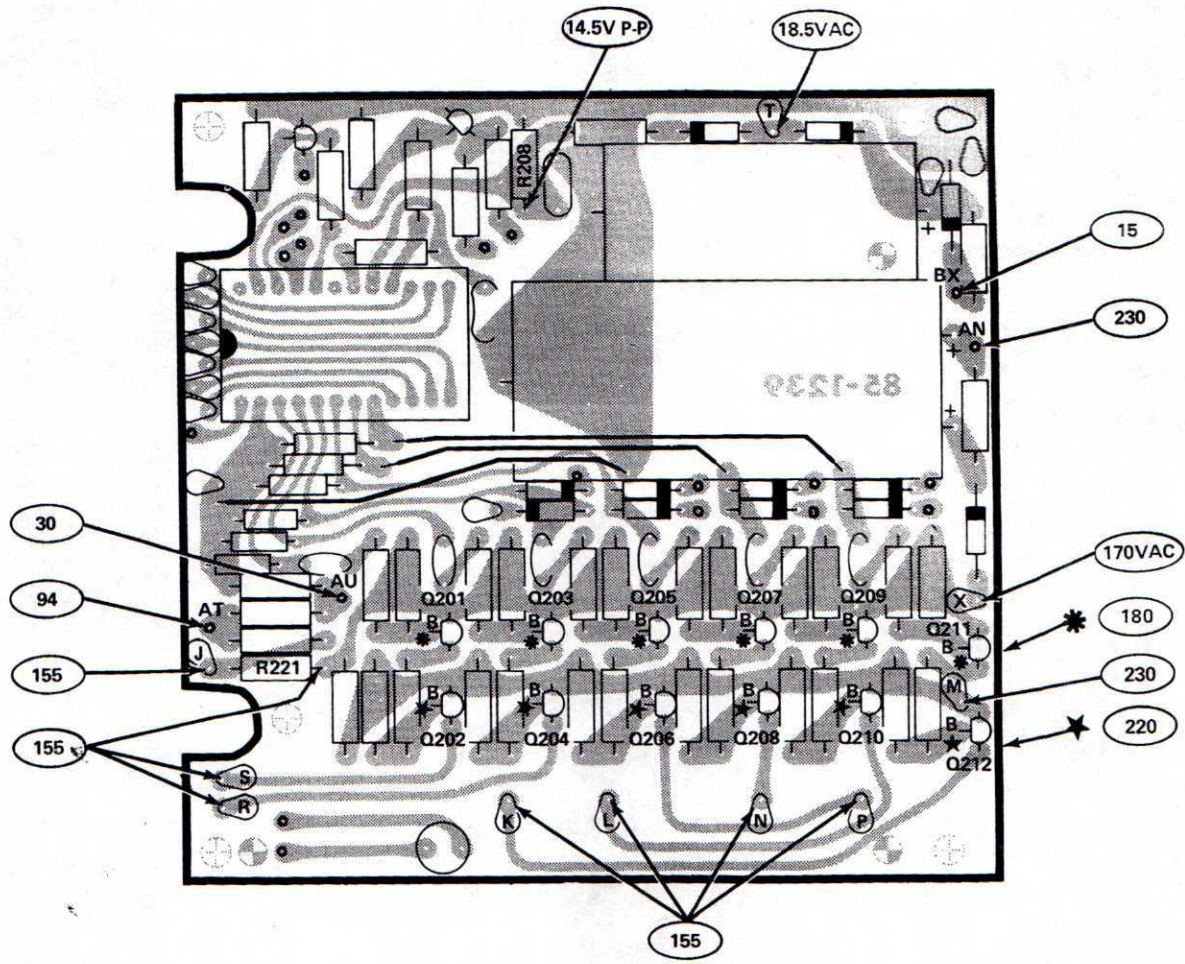

MAIN CIRCUIT BOARD
(Viewed from component side)

All voltages taken with IC201 removed.

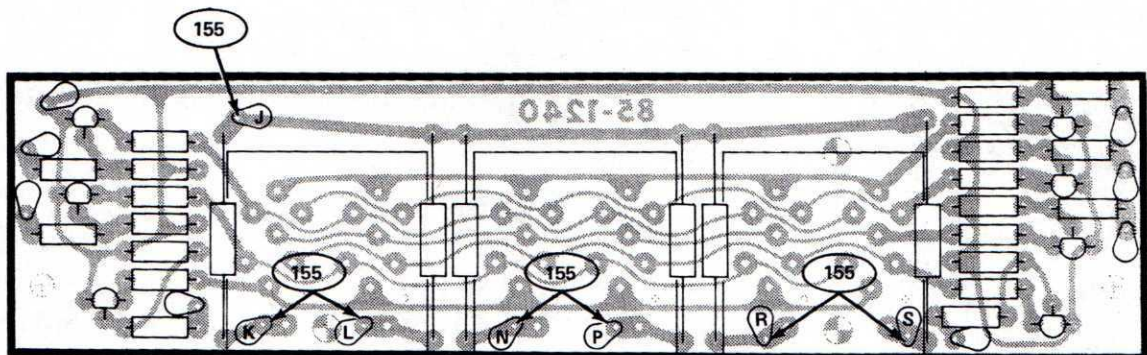

DISPLAY CIRCUIT BOARD
(Viewed from component side)

IDENTIFICATION CHART

COMPONENT	HEATH PART NUMBER	MAY BE REPLACED WITH	IDENTIFICATION																						
V101, V102, V103	411-286	SPERRY RAND SP-352	<div style="display: flex; justify-content: space-around;"> <div style="text-align: center;"> <p>VIEWED FROM FRONT</p> </div> <div style="text-align: center;"> <p>VIEWED FROM BACK</p> </div> </div> <table border="1" style="margin-top: 10px; width: 100%; border-collapse: collapse;"> <thead> <tr> <th style="width: 50%;">SEGMENT</th> <th style="width: 50%;">PIN NUMBER</th> </tr> </thead> <tbody> <tr><td>a</td><td>1</td></tr> <tr><td>b</td><td>2</td></tr> <tr><td>c</td><td>3</td></tr> <tr><td>d</td><td>4</td></tr> <tr><td>e</td><td>5</td></tr> <tr><td>f</td><td>6</td></tr> <tr><td>g</td><td>7</td></tr> <tr><td>DECIMAL</td><td>8 (NOT USED)</td></tr> <tr><td>ANODE</td><td>9</td></tr> <tr><td></td><td>10 (NOT USED)</td></tr> </tbody> </table>	SEGMENT	PIN NUMBER	a	1	b	2	c	3	d	4	e	5	f	6	g	7	DECIMAL	8 (NOT USED)	ANODE	9		10 (NOT USED)
SEGMENT	PIN NUMBER																								
a	1																								
b	2																								
c	3																								
d	4																								
e	5																								
f	6																								
g	7																								
DECIMAL	8 (NOT USED)																								
ANODE	9																								
	10 (NOT USED)																								
Q201, Q203, Q205, Q207, Q209, Q211, Q213, Q214	417-801	MPS-A20																							
Q202, Q204, Q206, Q208, Q210, Q212	417-295	MPS-L51																							
Q101-Q107	417-811	MPS-L01																							
ZD201	56-25	1N4166A ZENER DIODE, 15V, 17 mA	<p>NOTE: HEATH PART NUMBERS ARE STAMPED ON MOST DIODES.</p>																						
D204-D211	56-56	1N4149 SILICON DIODE, 75V, 10mA.																							
D201	57-27	1N2071 SILICON DIODE, 600V, 1A.																							
D202, D203	57-65	1N4002 SILICON DIODE, 100V, 1A.																							
IC201	443-601	MK5017AA	<p>TOP VIEW</p>																						



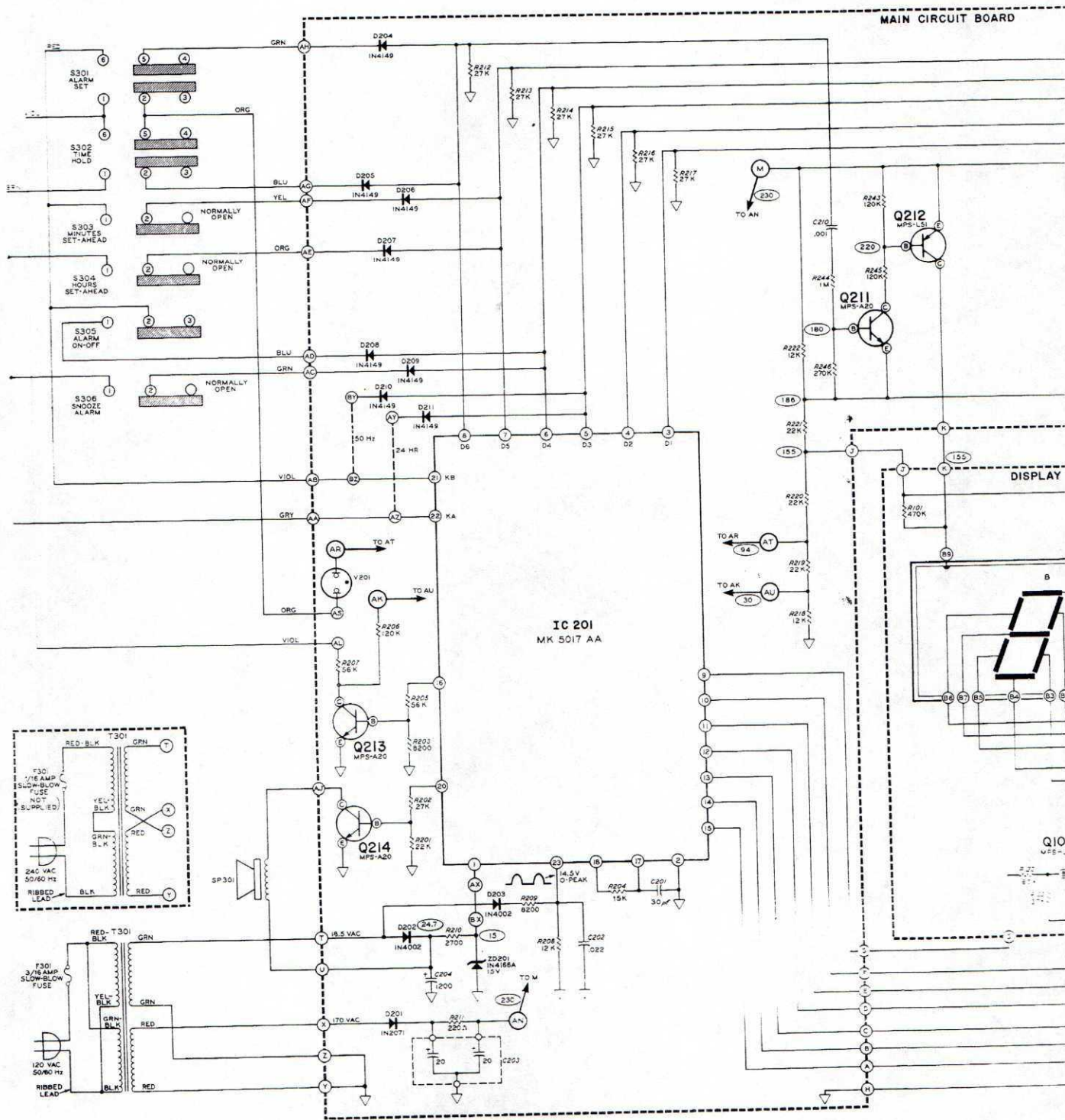

**SCHEMATIC OF THE
HEATHKIT[®]
ELECTRONIC CLOCK
MODEL GC-1005**

- NOTES:
1. ALL RESISTOR VALUES ARE IN OHMS K=1,000, M=1,000,000.
 2. ALL CAPACITOR VALUES ARE IN μ F UNLESS MARKED OTHERWISE.
 3. ∇ THIS SYMBOL INDICATES A CIRCUIT BOARD GROUND.
 4. \bigcirc THIS SYMBOL CONNECTION
 5. \bigcirc THIS SYMBOL A HIGH INP INDICATED ARE TAKEN

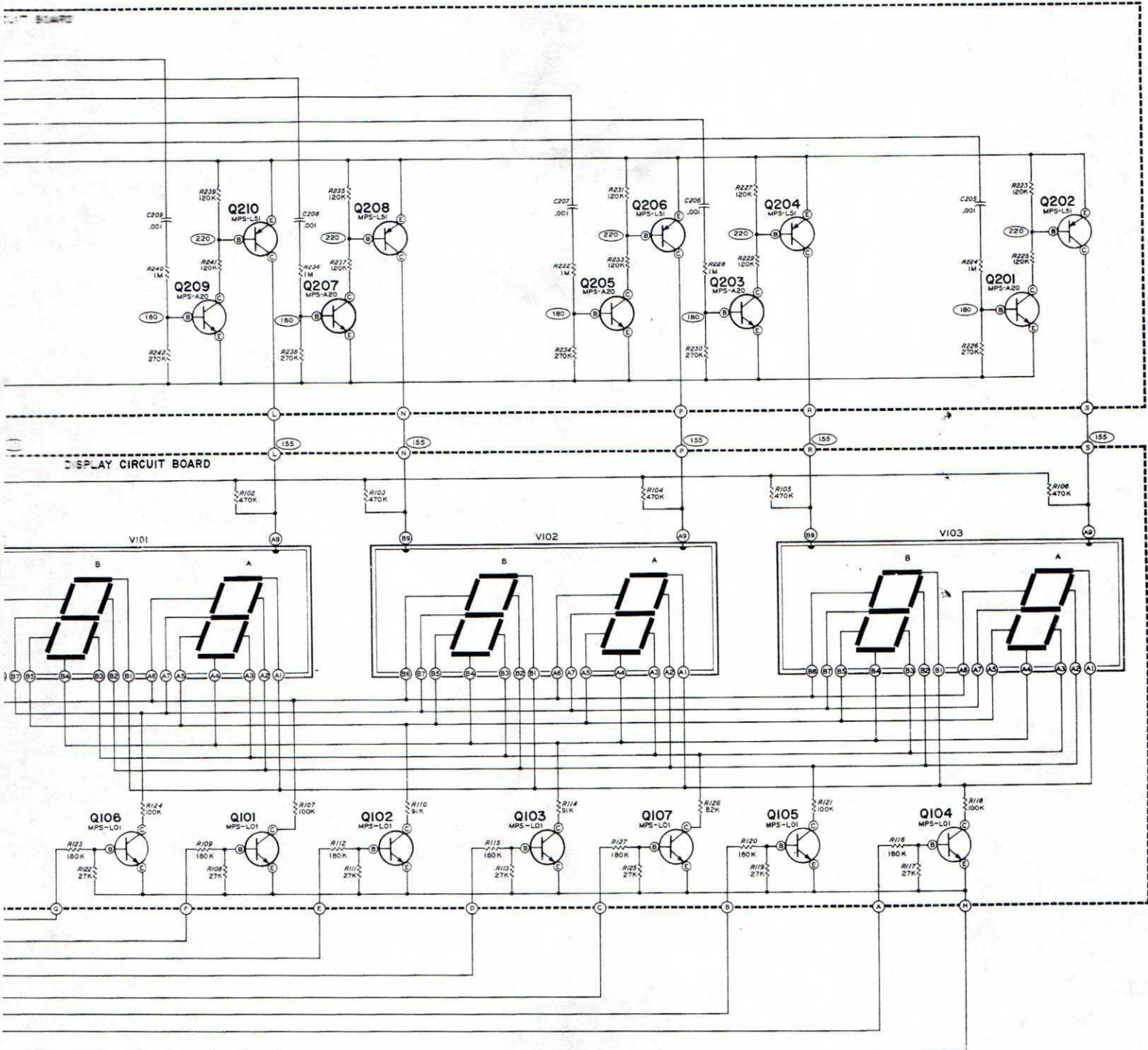

- 4. ○ THIS SYMBOL INDICATES A LETTERED CIRCUIT BOARD CONNECTION.
- 5. ○ THIS SYMBOL INDICATES A DC VOLTAGE MEASURED WITH A HIGH INPUT IMPEDANCE VOLTMMETER FROM THE POINT INDICATED TO GROUND. VOLTAGES MAY VARY ±10% AND ARE TAKEN WITH IC201 REMOVED.

CUSTOMER SERVICE

REPLACEMENT PARTS

If you need a replacement part, please fill in the Parts Order Form that is furnished and mail it to the Heath Company. Or, if you write a letter, include the:

- Part number and description as shown in the Parts List.
- Model number and Series number from the blue and white label.
- Date of purchase.
- Nature of the defect.

Please do not return parts to the factory unless they are requested. Parts that are damaged through carelessness or misuse by the kit builder will not be replaced without cost, and will not be considered in warranty.

Parts are also available at the Heathkit Electronic Centers listed in your catalog. Be sure to provide the Heath part number. Bring in the original part when you request a warranty replacement from a Heathkit Electronic Center.

NOTE: Replacement parts are maintained specifically to repair Heathkit products. Parts sales for other reasons will be declined.

TECHNICAL CONSULTATION

Need help with your Heathkit? Self-Service? Construction? Operation? Call or write for assistance. You'll find our Technical Consultants eager to help with just about any technical problem except "customizing" for unique applications.

The effectiveness of our consultation service depends on the information you furnish. Be sure to tell us:

- The Model number and Series number from the blue and white label.
- The date of purchase.
- An exact description of the difficulty.
- Everything you have done in attempting to correct the problem.

Also include switch positions, connections to other units, operating procedures, voltage readings, and any other information you think might be helpful.

Please do not send parts for testing, unless this is specifically requested by our Consultants.

Hints: Telephone traffic is lightest at midweek. . . please be sure your Manual and notes are on hand when you call.

Heathkit Electronic Center facilities are also available for telephone or "walk-in" personal assistance.

REPAIR SERVICE

Service facilities are available, if they are needed, to repair your completed kit. (Kits that have been modified, soldered with paste flux or acid core solder, cannot be accepted for repair.)

If it is convenient, personally deliver your kit to a Heathkit Electronic Center. For warranty parts replacement, supply a copy of the invoice or sales slip.

If you prefer to ship your kit to the factory, attach a letter containing the following information directly to the unit:

- Your name and address.
- Date of purchase.
- Copies of all correspondence relevant to the service of the kit.
- A brief description of the difficulty.
- Authorization to return your kit C.O.D. for the service and shipping charges. (This will reduce the possibility of delay.)

Check the equipment to see that all screws and parts are secured. (Do not include any wooden cabinets or color television picture tubes, as these are easily damaged in shipment.) Place the equipment in a strong carton with at least THREE INCHES of *resilient* packing material (shredded paper, excelsior, etc.) on all sides. Use additional packing material where there are protrusions (control sticks, large knobs, etc.). If the unit weighs over 15 lbs., place this carton in another one with 3/4" of packing material between the two.

Seal the carton with reinforced gummed tape, tie it with a strong cord, and mark it "Fragile" on at least two sides. Remember, the carrier will not accept liability for shipping damage if the unit is insufficiently packed. Ship by prepaid express, United Parcel Service, or insured Parcel Post to:

Heath Company
Service Department
Benton Harbor, Michigan 49022

HEATH

Schlumberger

HEATH COMPANY • BENTON HARBOR, MICHIGAN
THE WORLD'S FINEST ELECTRONIC EQUIPMENT IN KIT FORM

LITHO IN U.S.A.