

CONTENTS

PART I

Part I - Construction and Testing

	<u>Page</u>
Specifications:.....	3
Introduction:.....	4
Circuit Description:.....	4
Sweep Oscillator:.....	4
High Frequency Oscillator:.....	5
Marker Oscillator:.....	5
AF Modulation Oscillator:.....	6
Submarker Modulation Oscillator:.....	6
Output Circuit:.....	6
Power Supply:.....	7
Controls, Switches:.....	7
Preliminary Instructions:.....	9
Parts List:.....	9
Tools:.....	11
Solder Techniques:.....	11
Chassis Wiring and Soldering:.....	11
Step-by-step Procedure:.....	13
Step-By-Step Construction:.....	14
Main Chassis Plate Assembly:.....	14
Initial tube socket wiring:.....	17
Initial Panel Assembly and Mounting:.....	18
Underchassis Wiring:.....	19
Marker Oscillator Switch:.....	20
Prewiring:.....	20
Installation and Wiring:.....	20
Modulation Switch:.....	22
Prewiring:.....	22
Installation and Wiring:.....	23
Frequency Selector Switch:.....	24
Preassembly:.....	24
Mounting the coils:.....	24
Oscillator Subchassis Assembly:.....	25
Chassis Back Plate - Line Filter:.....	26
Oscillator Subchassis Installation:.....	28
Reactor Subchassis:.....	30
Preparing the Cabinet:.....	32
Test Cable:.....	33
Preliminary Checks:.....	33
With an Ohmmeter:.....	33
Without an Ohmmeter:.....	34
Calibration:.....	35
Preliminary Calibration:.....	35
Final Calibration:.....	36
In Case of Difficulty:.....	37

SPECIFICATIONS
INTRODUCTION
CIRCUIT DESCRIPTION
PRELIMINARY INSTRUCTIONS
STEP-BY-STEP CONSTRUCTION
PRELIMINARY CHECKS
CALIBRATION
IN CASE OF DIFFICULTY

PART II

INTRODUCTION
SERVICING BY SIGNAL INJECTION
ALIGNMENT PROCEDURES
SERVICING
REPLACEMENTS
SHIPPING INSTRUCTIONS
SPECIFICATION CHANGES
WARRANTY
SUGGESTED READING

	<u>Page</u>
Introduction:.....	38
Servicing by Signal Injection:.....	38
Alignment Procedures:.....	39
Method 1 - (IF Sweep Alignment):.....	39
Material required:.....	39
IF alignment:.....	40
Detector alignment:.....	41
Front End alignment:.....	41
Method II - (IF Peak Alignment):.....	42
Material required:.....	42
IF alignment:.....	42
Detector Alignment:.....	43
Discriminator:.....	43
Ratio detector:.....	43
Front End Alignment:.....	44
Summary:.....	44
Output Signals:.....	45
Servicing:.....	46
Service notes:.....	46
Technical Consultation Dept. :.....	47
Factory Service:.....	47
Local Service:.....	47
Replacements:.....	48
Shipping Instructions:.....	48
Specification Changes:.....	48
Warranty:.....	49
Suggested Reading:.....	49
Schematic Diagram:.....	Foldout

# ASSEMBLY AND OPERATION OF THE HEATHKIT FM TEST OSCILLATOR MODEL FMO-1



## SPECIFICATIONS

### Output Frequencies:

For RF Alignment:..... 90 mc (FM band low end).  
 100 mc (FM band middle range).  
 107 mc (FM band high end).

Modulation:..... 400-cycle incidental FM.

For IF and Detector Alignment:..... 10.7 mc sweep.  
 Sweep Width:..... 200 kc to over 1 mc, variable.

Markers:..... 10.7 mc (crystal).  
 100 kc submarkers.

Modulation:..... 400-cycle AM.

Other:..... 10.0 mc (crystal).  
 100 kc.  
 400-cycle audio.

Controls:..... Main frequency selector.  
 Modulation switch/  
 concentric level control.  
 Marker oscillator switch/  
 concentric level control.  
 Sweep width - power switch.  
 Output control.  
 RF-AF (source impedance) switch.

Tube Complement:..... 2 - 6U8.  
 Power Supply:..... Transformer, selenium rectifier.  
 Power Requirements:..... 105-125 V, 50/60 cycle, 12 watts.  
 Cabinet Size:..... 7 3/8" high x 4 3/4" wide x 4 3/8" deep.  
 Net Weight:..... 2 3/4 lbs.  
 Shipping Weight:..... 5 lbs.

### INTRODUCTION

The Heathkit FMO-1 Test Oscillator was designed to provide a signal source for the alignment and troubleshooting of practically all modern FM receivers and tuners.

Three switch-selected frequencies (90, 100 and 107 mc) are available for the adjustment of "front ends" (i. e., setting the oscillator to frequency and adjusting tracking). IF alignment may be carried out using the sweep method, the only additional equipment needed being an oscilloscope. A 10.7 mc crystal marker is provided to locate the center of the IF channel. Submarkers, appearing 100 kc each side of the 10.7 mc center frequency marker, may be used to indicate bandwidth. A 400-cycle audio signal is available for use in troubleshooting the audio sections of complete receivers and last stages of tuners. This audio, in addition, is used to provide a small amount of FM on the 90, 100 and 107 mc signals for an audible indication. It can be used to modulate the 10.7 mc marker oscillator, to provide an easy method of adjusting discriminator and ratio detector balance.

Each supplementary oscillator (crystal marker and 100 kc marker/audio) has its own level control, and all signals feed through a master output control. The source impedance of the FMO-1 is either low (approximately 51  $\Omega$ ) or high, switch selected. A pod is provided on the end of the test cable to allow termination with an appropriate load.

Extremely careful construction techniques must be used if the instrument is to work properly. As with any piece of high-frequency equipment, lead length and parts placement are quite critical. Very close adherence to this construction manual is of utmost necessity, if proper results are to be realized.

### CIRCUIT DESCRIPTION

#### Sweep Oscillator:

The basic circuit is a Hartley Oscillator. The actual sweeping is accomplished by varying the resonant frequency of the tank circuit, consisting of L1 and various shunt capacities (both lumped and stray). In the FMO-1 the frequency is varied by changing the effective capacity across the coil. This is achieved in a unique manner: The capacity of a semi-conductor diode junction varies inversely as the square root of the applied voltage. A 60-cycle voltage is applied to the diode, which causes the capacitance to change at a 60-cycle rate. This change in capacity is sufficient to shift the resonant frequency several hundred kilocycles, depending on the amplitude of the applied voltage.

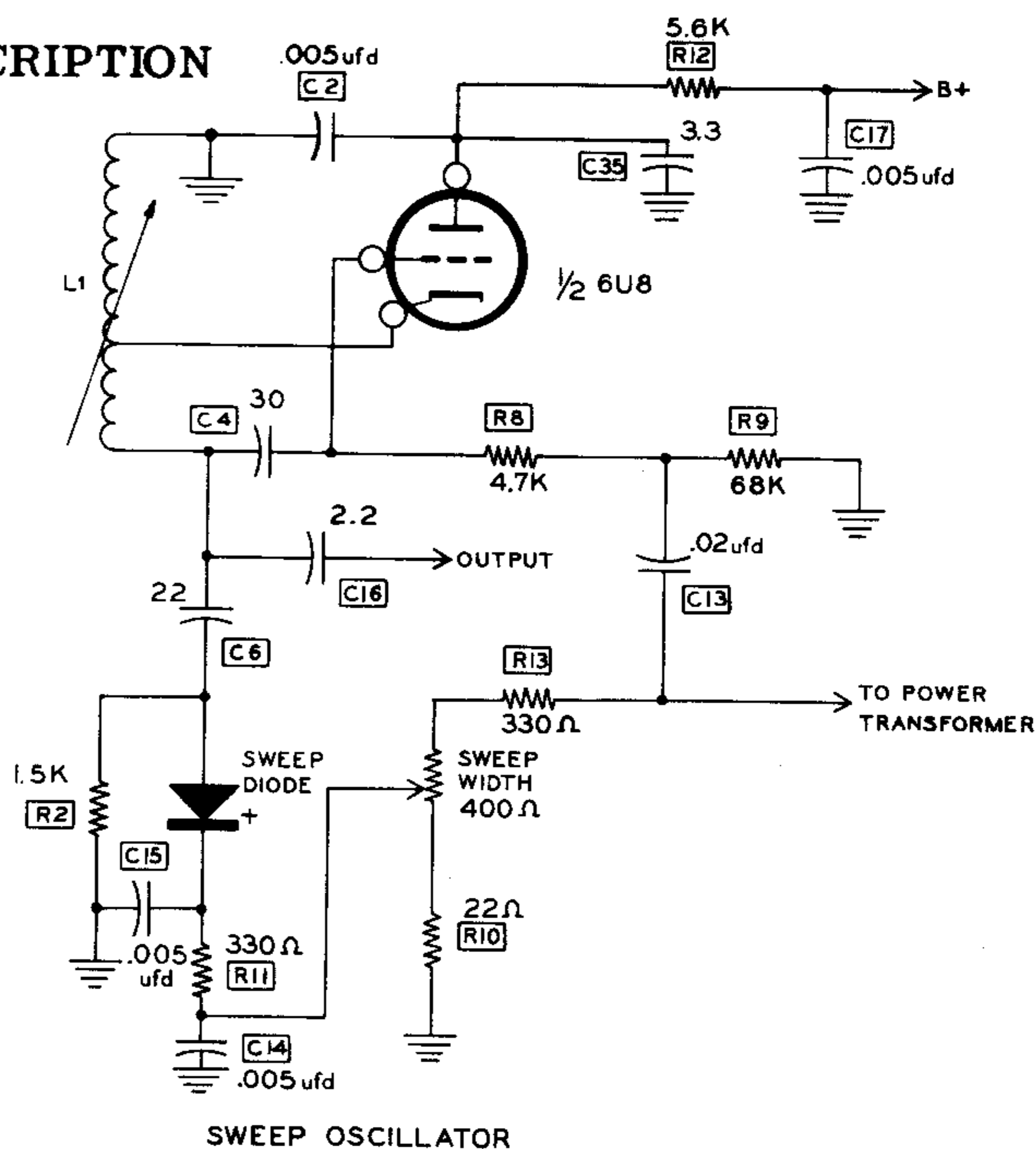

Capacitor C6, in series with the diode, serves to isolate the tank circuit from the applied AC voltage, and limits the maximum capacity applied to the tank circuit by the diode.

Resistor R2 is the ground return for the 60-cycle sweep voltage applied across the diode. R11 limits the current through the diode to prevent over heating and consequent damage. R10 and R13 determine the range of the sweep width control. C13 couples 60-cycle voltage to an isolation network composed of R8 and R9. A portion of the voltage is then applied to the grid of the oscillator tube for "blanking". This blanking voltage turns the oscillator off for approximately half the sweep cycle, which prevents a double oscilloscope image during operation.

C2, C14, C15 and C17 are merely bypass capacitors. R12 serves no useful purpose in this mode of operation, but is used when the circuit is switched over to the 90, 100 or 107 mc oscillator.

C16 couples the signal to the grid of the cathode follower. C4 works in conjunction with R8 and R9 to provide grid-leak bias. C35 increases the stability of the circuit.

### High Frequency Oscillator:

This circuit utilizes a Colpitts form of oscillator. The tank circuit is formed by L2 (or L3 or L4) and C1-C3. C5 and R3 are used to obtain grid-leak bias for the tube. C2, in this case, serves to couple energy from the tube plate back into the tank circuit. Audio voltage is injected into the plate supply voltage by means of C18 and R1. Changes in plate voltage in this type of oscillator cause a slight shift in frequency, which is utilized for the audible tone used in front end alignment. C17 is a bypass capacitor to prevent RF from getting back into the audio oscillator. R12 serves as the plate load for the oscillator tube. C16 couples the signal to the grid of the cathode follower output stage. C35, once again, helps stabilize the circuit.

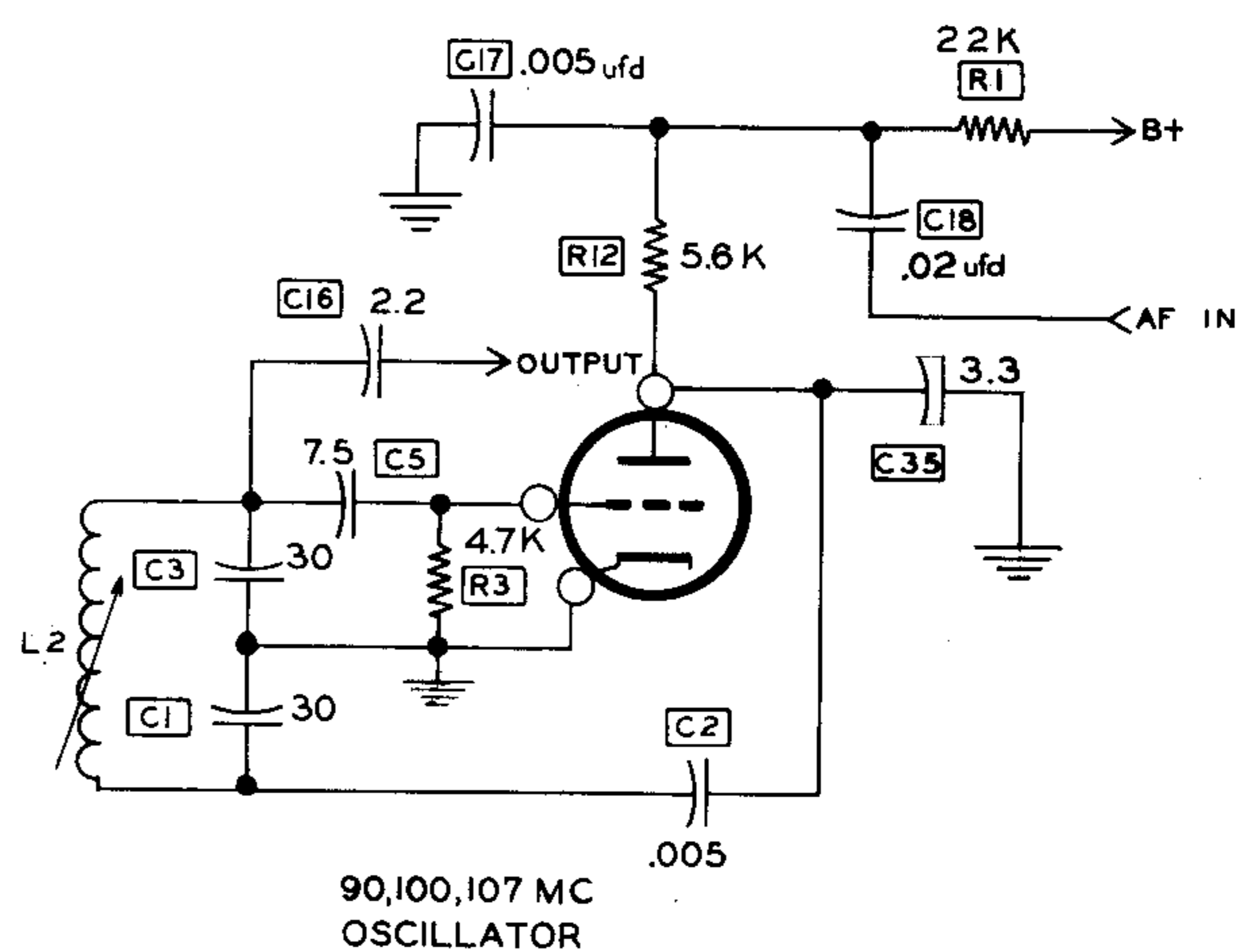

### Marker Oscillator:

The marker oscillator is a straight-forward electron-coupled Pierce Crystal Oscillator. The tube operates with only contact bias, to create some distortion in the output wave to obtain harmonics.

The level control actually varies the B+ delivered to the tube, and consequently varies the output. R20 and R21 are the screen dropping resistor and plate load resistor, respectively. C31 is a blocking capacitor, to keep the screen voltage from appearing across the crystal. R22 is the grid return resistor. C8 couples the signal to the cathode of the cathode follower. R19 is an isolation resistor, used when the 100 kc submarker or audio is applied to the oscillator.

Varying the B+ or applying modulation causes a slight shift in the operating frequency of the oscillator, but in practice the effects are so slight as to be negligible. C33 and C34 bring the input capacity up to about 24  $\mu\mu\text{f}$ .

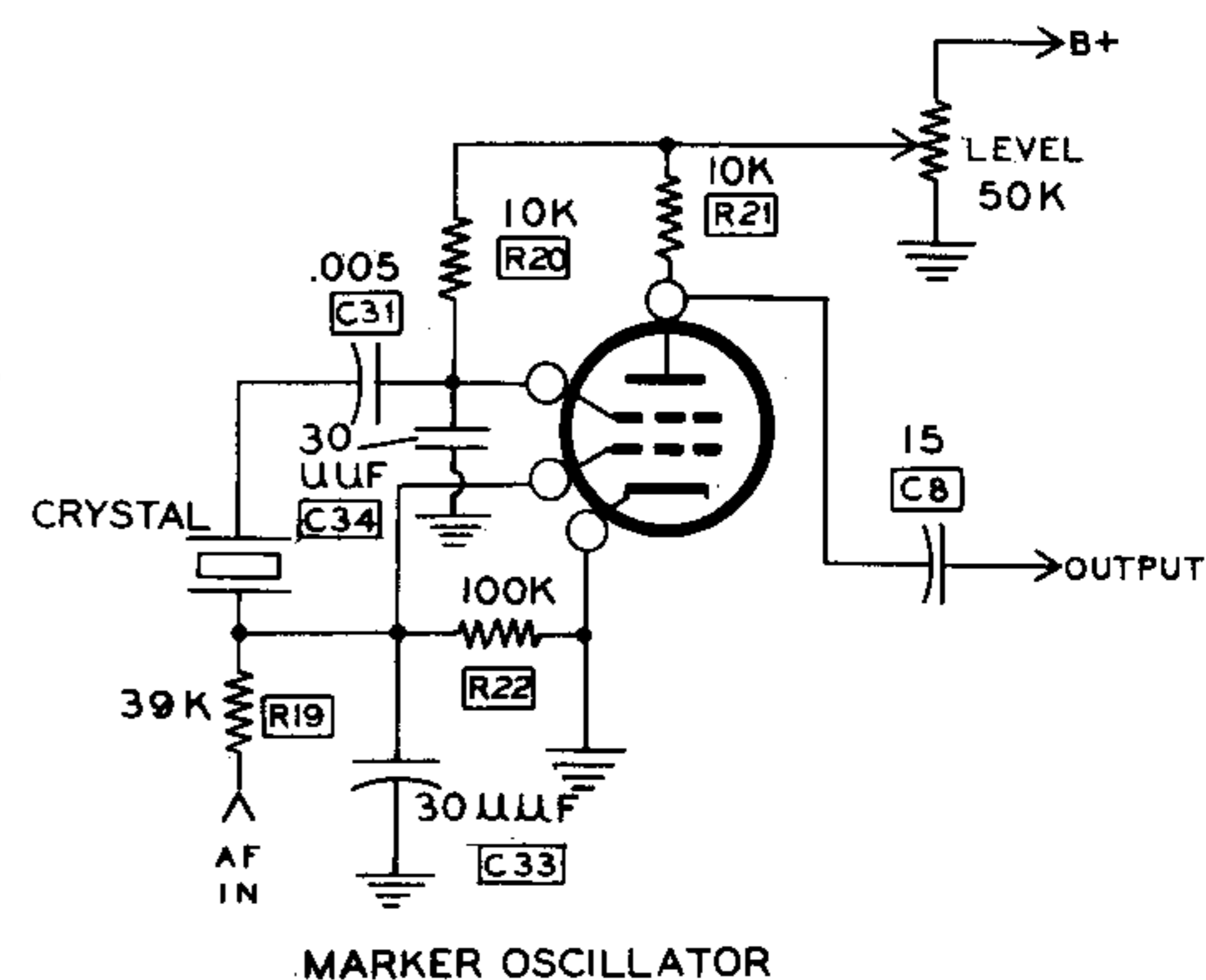

Submarkers will appear on each side of the 10.7 mc center-frequency marker, by virtue of the fact that two signals of different frequencies, when mixed in a non-linear device (the tube in this case), result in signals of the sum and the difference of the two, together with each original

frequency. Since the IF's will not pass 100 kc, that which remains apparent is a marker pip at 10.6 mc (the difference) and 10.8 mc (the sum). Because of the harmonic content of the two original signals, it may be possible to see additional side bands at 10.5 mc and 10.9 mc.

### AF Modulation Oscillator:

Another Hartley Oscillator, this electron-coupled circuit provides the audio frequency used in the instrument. The frequency is approximately 400 cycles, but no effort has been made to insure any accuracy, since the prime requirement is an audible signal for use in modulating one of the oscillators or as a signal source for audio system troubleshooting.

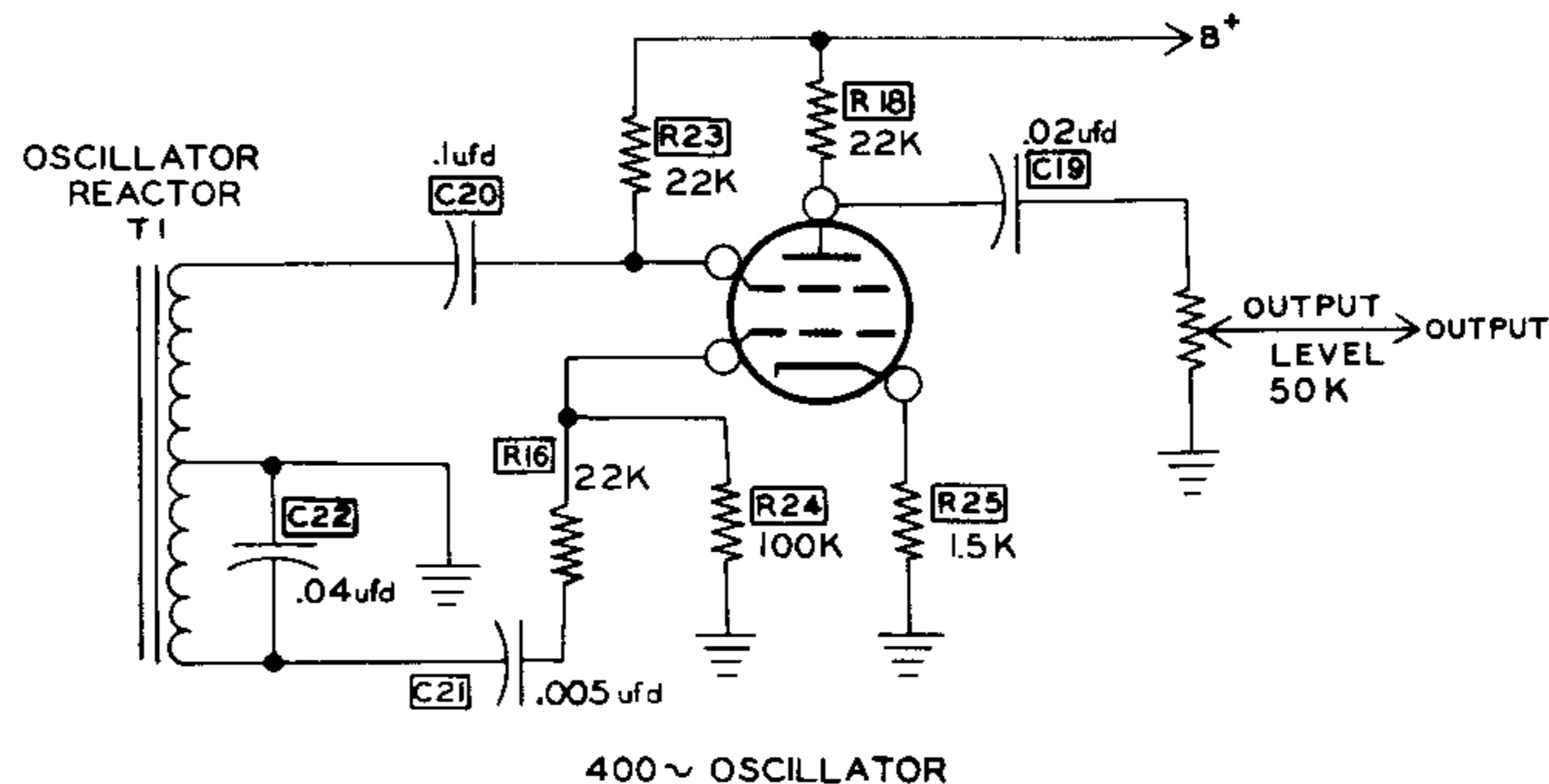

T1 and C22 are the main frequency determining elements in the circuit. C20 keeps the DC screen voltage out of the tuned circuit. R23 and R18 are the screen dropping and plate load resistors, respectively. C21 is the grid coupling capacitor, and R24 the grid return to ground. R25 provides operating bias for the tube, which in this case is biased Class A. R16 provides some degeneration to improve the waveform characteristics. The waveform is not sufficiently pure, however, to be used as a signal source for distortion measurements. The output is coupled through C19 to the level control.

### Submarker Modulation Oscillator:

L7 and C29 are tuned to 100 kc in this electron-coupled Hartley circuit. The components function in this circuit the same as in the 400-cycle oscillator circuit, with appropriate changes in value. R16 is omitted, however, since waveform distortion is desirable from the standpoint of harmonic content.

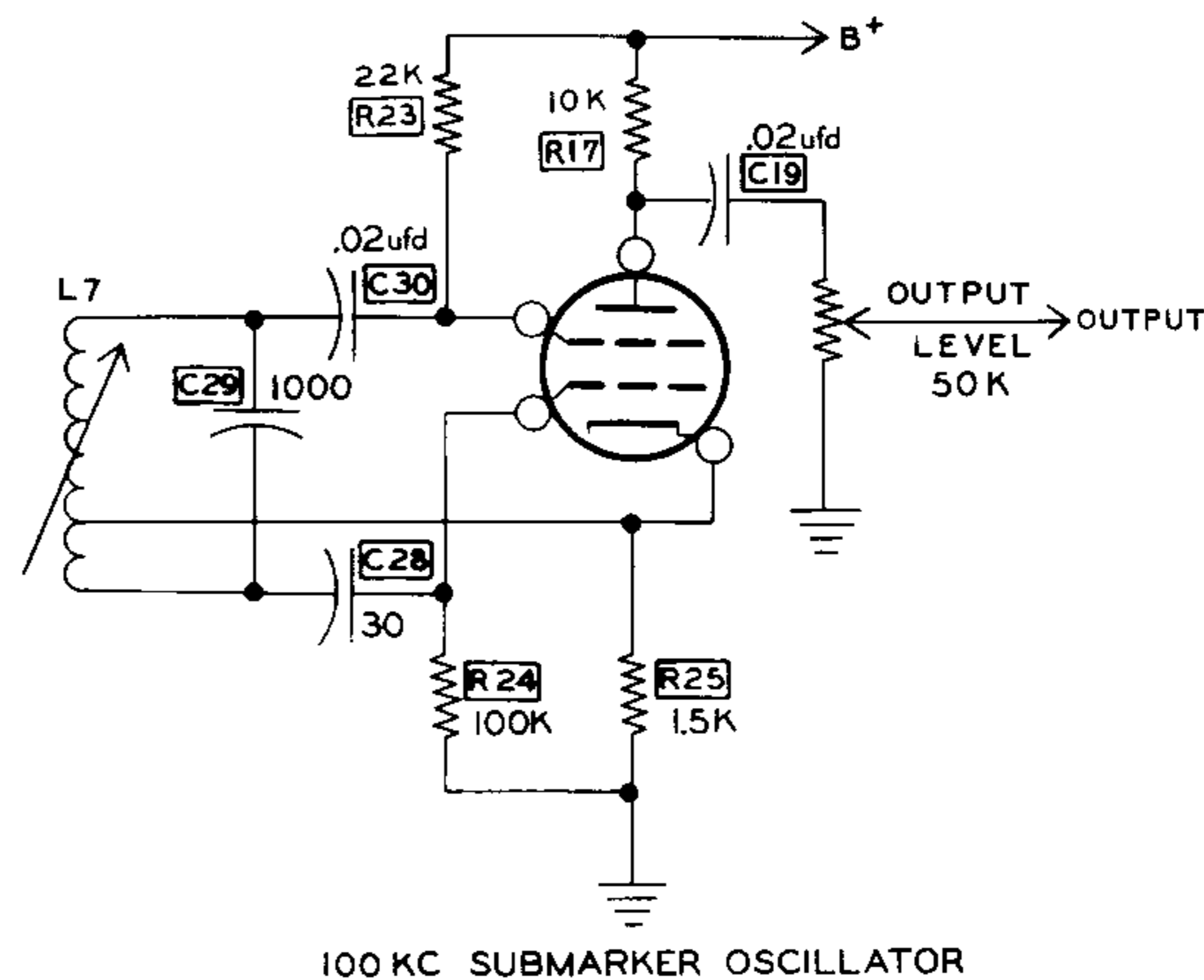

### The Output Circuit:

The output circuit consists of a straight cathode follower coupled to a special output control through C7. SW2 selects the source impedance seen by the test cable. For RF work, R4 and R5 are switched in for low impedance. AF work requires a high impedance, so the switch opens the resistor to ground (R5) and shorts out the series resistor (R4).

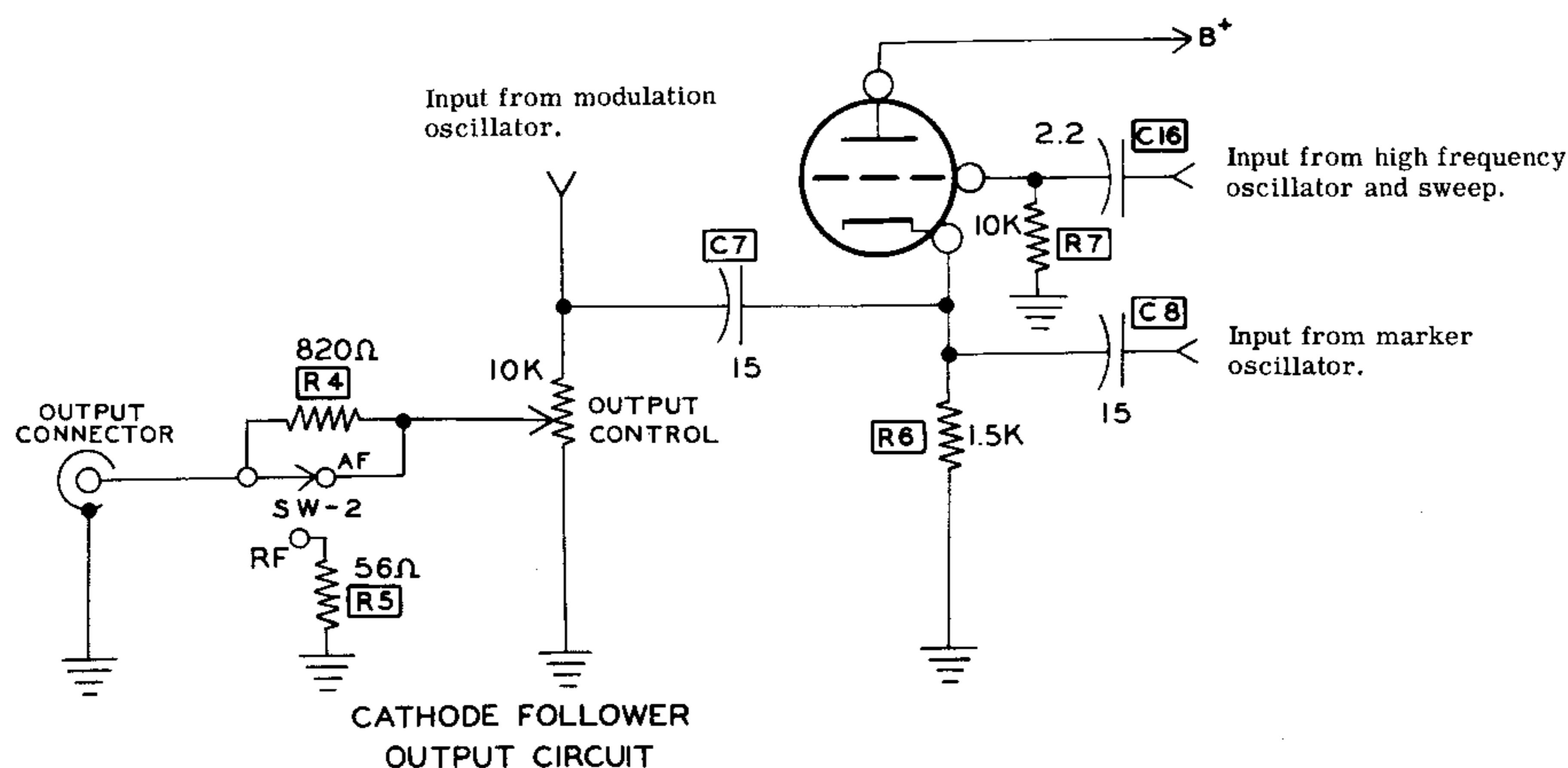

C16 couples the signal from the high frequency or sweep oscillator circuit to the grid of the tube. R7 serves as the grid return. R6 is the cathode load resistor. The crystal or "marker" oscillator output is fed through C8 to the cathode, since a non-linear element in the circuit would cause "beating" between the two signals instead of just an adding of signals.

The output from the 400-cycle/100 kc oscillator (with the MODULATION switch in the "OUT" position) is fed directly to the high side of the OUTPUT control, since the low frequencies involved will not pass readily through C7 due to its low value.

### The Power Supply:

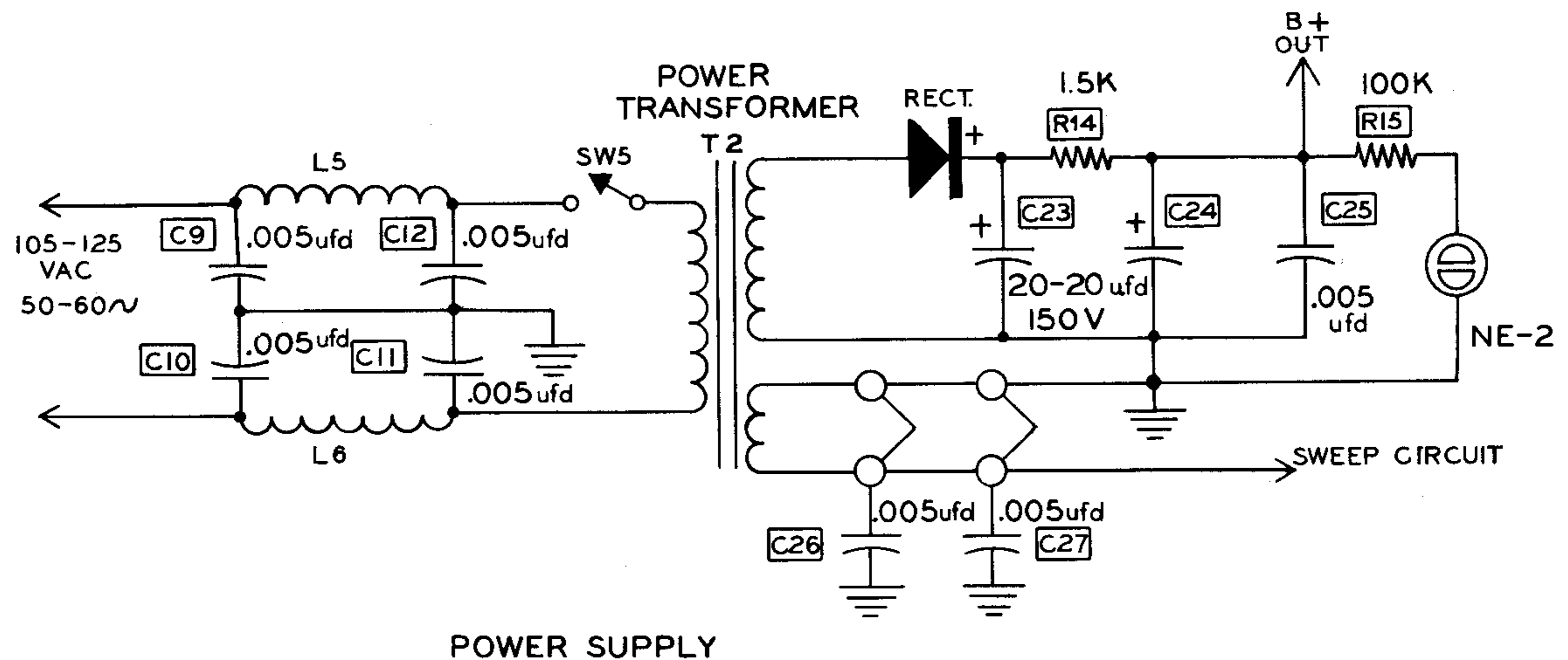

The power supply is conventional, being transformer operated. A half-wave selenium rectifier converts the AC into pulsating DC, which is smoothed out into DC by the filter composed of C23, R14 and C24. C25 is an RF bypass capacitor, as are C26 and C27 (which appear directly at the tube sockets). R15 is a current-limiter for the neon pilot light. SW5 is on the SWEEP WIDTH control and is actuated at the extreme counterclockwise end of rotation of the control. The filter made up of L5, L6, C9, C10, C11 and C12 keeps the RF out of the power lines, to help minimize direct radiation into the tuner or receiver under test.

### Controls and Switches:

The top panel switch selects the appropriate coil for a given signal and connects it, together with its appropriate circuitry, to the tube:

<u>Position</u>	<u>The switch</u>
OFF	Disconnects B+ to V1-A
10.7 MC SWEEP	Selects appropriate coil, grounds C2, connects the sweep circuitry and blanking, making connections to tube and connects B+. Also connects C16 to the tank circuit.
90 MC	Selects appropriate coil and bridges it with C1 and C3. Connects C2 to one end of the coil, grounds cathode, connects the other grid return, R3. Connects R1 into the B+ line for a modulation load. Connects B+ and connects the tube to the circuit.
100 MC	
107 MC	

### The MODULATION switch

<u>Position</u>	<u>The switch</u>
OFF	Disconnects B+ to V1-B.
400 ~ MOD	Selects the tuned circuit for the 400-cycle signal and connects it to the tube. Connects B+ and feeds the signal to the MARKER switch.
400 ~ OUT	Same as 400~ MOD except that it feeds the signal to the OUTPUT control.
100 KC MOD	Selects the 100 kc tuned circuit and connects it to the tube. Connects B+ and feeds the signal to the MARKER switch.
100 KC OUT	Same as above except it feeds the signal to the OUTPUT control.

The LEVEL control adjusts the oscillator circuit output signal level.

### The MARKER switch

<u>Position</u>	<u>The switch</u>
OFF	Disconnects B+ to V2-B, completes the modulation circuit to the high frequency oscillator.
10.7 MC	Connects B+ to V2-B, selects the 10.7 mc crystal and connects the modulation circuit to the marker oscillator.
10.0 MC	Same as above except that it selects the 10.0 mc crystal.

The LEVEL control adjusts the marker injection.

### The SWEEP WIDTH control

The SWEEP WIDTH control adjusts the amplitude of the AC voltage applied to the sweep diode, hence adjusts the width of the sweep. The power switch is actuated at the extreme counterclockwise end of rotation of this control.

### RF-AF switch

This switch selects the source impedance of the instrument (i. e. , the impedance which the test cable sees, looking back toward the instrument). The RF position inserts a resistor between the OUTPUT control and output connector and connects another resistor from the output to ground. In the AF position, the series resistor is shorted out and the shunt resistor is disconnected.

### OUTPUT control

The OUTPUT control selects that portion of the output signal which is to be applied to the test cable. It is a special, limited rotation control, designed to minimize the capacity between the input and output terminals of the control so as to keep RF leakage across the control to a small value.



## PRELIMINARY INSTRUCTIONS

This manual is supplied to assist you in every way to complete your kit with the least possible chance for error. While the arrangement shown is probably not the only satisfactory arrangement, nevertheless it is the result of extensive experimentation and trial. If followed carefully, it will result in a stable instrument, operating at a high degree of accuracy and dependability. We suggest that you retain the manual in your files for future reference, both in the use of the instrument and for its maintenance.

UNPACK THE KIT CAREFULLY AND CHECK EACH PART AGAINST THE PARTS LIST. In so doing, you will become acquainted with the parts. Refer to the charts and other information on the inside covers of your manual to help you identify the components. If some shortage or parts damage is found in checking the Parts List, please read the REPLACEMENT section and supply the information called for therein, and include all inspection slips in your letter to us. Hardware items are counted by weight and there may be a few more or less than the quantity specified. If a few are missing, please obtain them locally if at all possible.

In order to expedite delivery to you, we are occasionally forced to make minor substitution of parts. Such substitutions are carefully checked before they are approved. The parts supplied will work satisfactorily. In checking the Parts List for resistors, for example, you may find that a resistor with a 5% tolerance has been substituted for a resistor with a 10% tolerance, as shown on the Parts List. These changes are self-evident and are mentioned here only to prevent confusion in checking the contents of your kit.

Resistors generally have a tolerance rating of 10% unless otherwise stated in the Parts List. Tolerances on capacitors are generally even greater. Limits of +100% and -50% are common for electrolytic capacitors.

### PARTS LIST

PART No.	PARTS Per Kit	DESCRIPTION	PART No.	PARTS Per Kit	DESCRIPTION
<b>Resistors</b>			<b>Capacitors</b>		
1-49	1 ✓	22 Ω 1/2 watt (red-red-black)	21-50	1 ✓	2.2 μμf molded phenolic (red-red-white)
1-83	2 ✓	56 Ω 1/2 watt (green-blue-black)	21-33	1 ✓	3.3 μμf disc ceramic
1-4	2 ✓	330 Ω 1/2 watt (orange-orange-brown)	20-52	1 ✓	7.5 μμf mica
1-8	1 ✓	820 Ω 1/2 watt (gray-red-brown)	20-29	2 ✓	15 μμf mica (brown-green-black)
1-11	4 ✓	1.5 KΩ 1/2 watt (brown-green-red)	20-99	1 ✓	22 μμf mica
1-16	2 ✓	4.7 KΩ 1/2 watt (yellow-violet-red)	20-100	6 ✓	30 μμf mica
1-18	1 ✓	5.6 KΩ 1/2 watt (green-blue-red)	20-70	1 ✓	1000 μμf mica (brown-black-red)
1-20	4 ✓	10 KΩ 1/2 watt (brown-black-orange)	21-27	15 ✓	.005 μfd ceramic
1-22	4 ✓	22 KΩ 1/2 watt (red-red-orange)	21-31	4 ✓	.02 μfd ceramic
1-67	1 ✓	39 KΩ 1/2 watt (orange-white-orange)	23-74	1 ✓	.04 μfd plastic molded
1-60	1 ✓	68 KΩ 1/2 watt (blue-gray-orange)	23-28	1 ✓	.1 μfd plastic molded
1-26	3 ✓	100 KΩ 1/2 watt (brown-black-yellow)	25-7	1 ✓	20-20 μfd at 150 V electrolytic
			<b>Controls-Switches</b>		
			10-105	1 ✓	Output control, restricted rotation
			19-34	1 ✓	400 Ω control w/SPST switch
			60-4	1 ✓	2-position slide switch

<u>PART No.</u>	<u>PARTS Per Kit</u>	<u>DESCRIPTION</u>	<u>PART No.</u>	<u>PARTS Per Kit</u>	<u>DESCRIPTION</u>
<b>Controls-Switches (cont'd.)</b>			<b>Hardware</b>		
63-227	1 ✓	3-position switch w/control	250-2	6 ✓	3-48 x 5/16" round head screw
63-226	1 ✓	5-position switch w/control	250-10	2 ✓	6-32 x 1/2" stove head screw
63-225	1 ✓	5-position switch	250-48	1 ✓	6-32 x 1/2" round head screw
<b>Coils-Transformers</b>			250-70	2 ✓	6-32 x 3/16" flat head screw
45-35	2 ✓	Line choke coil	250-83	2 ✓	#10 handle screw
51-44	1 ✓	Oscillator reactor	250-89	13 ✓	6-32 x 3/8" binder head screw
54-92	1 ✓	Power transformer	252-1	6 ✓	3-48 nut
141-2	1 ✓	Coil set	252-3	17 ✓	6-32 nut
Consisting of:			252-7	5 ✓	Control nut
40-243	1 ✓	100 kc oscillator coil (green dot)	252-22	2 ✓	6-32 speednut
40-269	1 ✓	90 mc oscillator coil (white dot)	252-32	1 ✓	Push on speednut (for pilot light)
40-270	1 ✓	100 mc oscillator coil (red dot)	253-10	5 ✓	Control flat washer
40-271	1 ✓	107 mc oscillator coil (yellow dot)	254-1	21 ✓	#6 internal tooth lockwasher
40-268	1 ✓	10.7 mc sweep oscillator coil (blue dot)	254-5	4 ✓	Control lockwasher
<b>Rectifier-Crystals</b>			254-6	6 ✓	#6 external tooth lockwasher
57-13	1 ✓	Selenium rectifier	254-7	7 ✓	#3 lockwasher
56-4	1 ✓	Crystal diode	259-1	2 ✓	#6 solder lug
404-38	1 ✓	10.0 mc crystal	259-10	3 ✓	Control solder lug
404-39	1 ✓	10.7 mc crystal	<b>Knobs</b>		
<b>Terminal Strips-Connectors-Sockets</b>			462-19	2 ✓	Gray plastic, small
431-14	3 ✓	2-lug terminal strip	462-32	2 ✓	Gray plastic for concentric shafts
431-38	2 ✓	3-lug terminal strip (miniature)	462-36	2 ✓	Red plastic for concentric shafts
431-12	2 ✓	4-lug terminal strip	100-M54	1 ✓	Gray plastic, large
431-11	1 ✓	5-lug terminal strip	<b>Metal Parts</b>		
432-1	1 ✓	Cable connector	90-26	1 ✓	Cabinet
432-3	1 ✓	Panel connector	200-M239	1 ✓	Main chassis plate
434-74	2 ✓	Crystal socket	200-M240	1 ✓	Oscillator tube subchassis
434-77	2 ✓	9-pin tube socket	200-M241	1 ✓	Reactor subchassis
<b>Insulators-Bushings-Rubber Parts</b>			204-M286	1 ✓	Subchassis support bracket
70-5	1 ✓	Black banana plug sleeve	205-M195	1 ✓	Chassis back plate
70-6	1 ✓	Red banana plug sleeve	203-186F289	1 ✓	Front panel
73-1	2 ✓	3/8" rubber grommet	<b>Miscellaneous</b>		
75-15	1 ✓	Terminal half-shell, drilled	89-1	1 ✓	Line cord
75-16	1 ✓	Terminal half-shell, plain	211-4	1 ✓	Cabinet handle
75-24	1 ✓	Line cord strain relief bushing	260-16	2 ✓	Alligator clip
100-M16B	1 ✓	Black binding post cap	343-2	1 ✓	Length shield test lead wire
100-M16R	1 ✓	Red binding post cap	344-1	1 ✓	Length hookup wire
261-4	4 ✓	Rubber foot	346-1	1 ✓	Length sleeving
			411-80	2 ✓	6U8 tube
			412-13	1 ✓	Neon pilot light
			427-2	2 ✓	Binding post base
			438-13	2 ✓	Banana plug
			490-1	1 ✓	Alignment tool
			595-294	1 ✓	Instruction manual

## Tools:

Proper tools are a definite asset to any job, and kit construction is no exception.

Necessary tools comprise screwdrivers to fit #3, #6 and #10 slotted head screws: long nose pliers (sometimes called "needle-nose"); diagonal cutting pliers; solder iron or gun (30-100 watt). An alignment tool is supplied with the kit, and more will be said about it in the CALIBRATION section of the manual.

Desirable tools: nut drivers, open end wrenches and wire strippers.

### PROPER SOLDERING TECHNIQUES

Only a small percentage of Heathkit purchasers find it necessary to return an instrument for factory service. Of these instruments, by far the largest proportion of malfunctions are due to poor or improper soldering.

If terminals are bright and clean and free of wax, frayed insulation and other foreign substances, no difficulty will be experienced in soldering. Correctly soldered connections are essential if the performance engineered into a kit is to be fully realized. If you are a beginner with no experience in soldering, a half hour's practice with some odd lengths of wire may be a worthwhile investment.

For most wiring, a 30 to 100 watt iron or its equivalent in a soldering gun is very satisfactory. A lower wattage iron than this may not heat the connection enough to flow the solder smoothly over the joint. Keep the iron tip clean and bright by wiping it from time to time with a cloth.

### CHASSIS WIRING AND SOLDERING

1. Unless otherwise indicated, all wire used is the type with the colored insulation (hookup wire).
2. Leads on resistors, capacitors and transformers are generally much longer than they need to be to make the indicated connections. In these cases, the excess leads should be cut off before the part is added to the chassis. In general, the leads should be just long enough to reach their terminating points. Wherever there is a possibility of bare leads shorting to other parts or to the chassis, the leads should be covered with insulating sleeving. Where insulating sleeving is required the phrase "use sleeving" will be included in the associated construction steps.
3. Crimp or bend the lead (or leads) around the terminal to form a good joint without relying on solder for physical strength. If the wire is too large to allow bending, position the wire so that a good solder connection can still be made.
4. Position the work, if possible, so that gravity will help to keep the solder where you want it.
5. Place a flat side of the soldering iron tip against the joint to be soldered until it is heated sufficiently to melt the solder.
6. Then place the solder against the heated terminal and it will immediately flow over the joint; use only enough solder to thoroughly wet the junction. It is usually not necessary to fill the entire hole in the terminal with solder.
7. Remove the solder and then the iron from the completed junction. Use care not to move the leads until the solder is solidified.

- (✓) Grasp the bushing firmly with a pair of pliers and seat it in the hole. This should produce a slight loop in the line cord wires adjacent to the terminal strip.
- (✓) Place the partially completed chassis and back plate in the relative positions shown in Figure 10. Cut the black transformer lead coming up through grommet C to the same length as the hookup wire coming through the same grommet.
- (✓) Connect the black transformer lead to lug 5 of terminal strip J (S-3).
- (✓) Connect the hookup wire to lug 1 of terminal strip J (S-3).
- (✓) Dress the length of hookup wire connected to lug 2 of terminal strip D around the electrolytic capacitor as shown. Connect the other end of this wire to lug 3 of terminal strip J (S-5).  
NOTE: Four of the leads were soldered when the line filter was wired.

### OSCILLATOR SUBCHASSIS INSTALLATION

- (✓) Secure the subchassis support bracket to the panel by mounting the Frequency Selector switch, as shown in Figure 11. Use a control solder lug, formed as shown, between the switch and subchassis bracket, and a flat washer between the panel and nut. Orient the switch as indicated, and tighten the nut securely. The end of the solder lug should be adjacent to lug 2 of wafer FD.
- (✓) Wrap the free end of the .005  $\mu$ fd disc capacitor previously connected to lug 6 of wafer FD around the solder lug once (NS), and then on to lug 2 of wafer FD (NS). Now solder the lead to the solder lug (S-1).

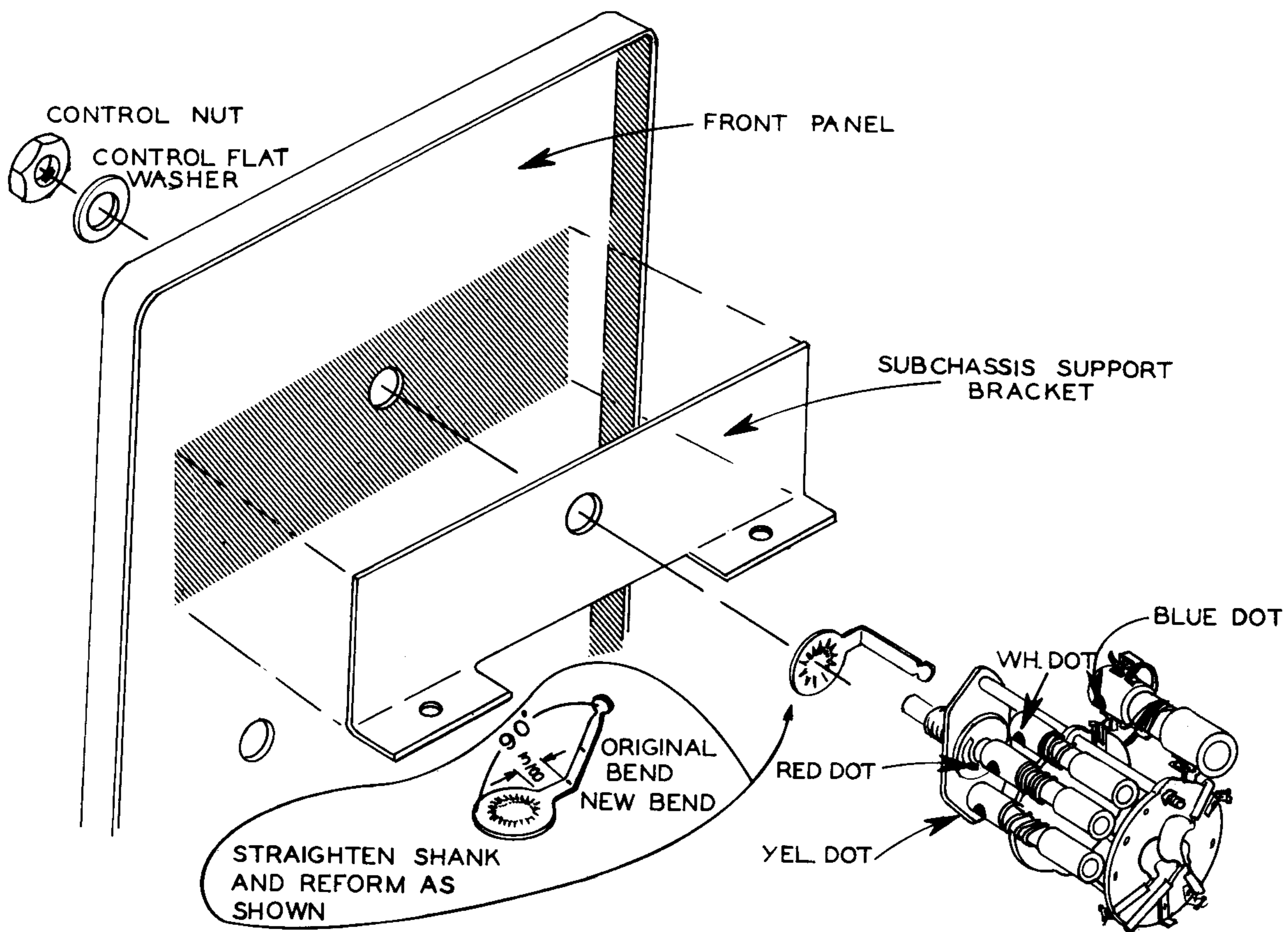

Figure 11

(✓) Connect the free lead of the .02  $\mu$ fd capacitor connected to lug 3 of the MARKER switch to lug 6 of wafer FD on the Frequency Selector switch (NS).

(✓) Connect the free end of the wire from lug 7 on FD to lug 7 on the MARKER switch (S-2).

NOTE: In the following steps be certain the subchassis is not pulled downward toward the Main Frequency Selector switch because of leads pulled too tight. Check from time to time by placing the back plate into position.

(✓) Mount the oscillator subchassis in position as shown in Figure 12, using 6-32 hardware as indicated in Figure 10 on Page 27. It will be helpful to dress the leads in the direction of their connections before mounting.

(✓) Connect the loose end of the wire from lug 1 of terminal strip G to lug 6 of wafer FD on the Frequency Selector switch (S-4).

(✓) Connect the wire from lug 2 of terminal strip G to lug 2 of wafer FD on the Frequency Selector switch (NS).

(✓) Connect one of the wires coming from the MODULATION switchground lug to lug 2 of wafer FD on the Frequency Selector switch (S-3).

(✓) Connect the wire from lug 8 of socket V1 to lug 4 of wafer FD on the Frequency Selector switch (S-1).

(✓) Route the wire from lug 1 of socket V1 over the socket and terminal strip G. Connect it to lug 4 of wafer RD on the Frequency Selector switch (S-2). This wire should be dressed in a large loop, which crosses terminal strip G directly above lug 3.

(✓) Connect the free lead of the 4.7 K $\Omega$  resistor connected to lug 2 of terminal strip G to lug 5 of wafer RD on the Frequency Selector switch (S-2).

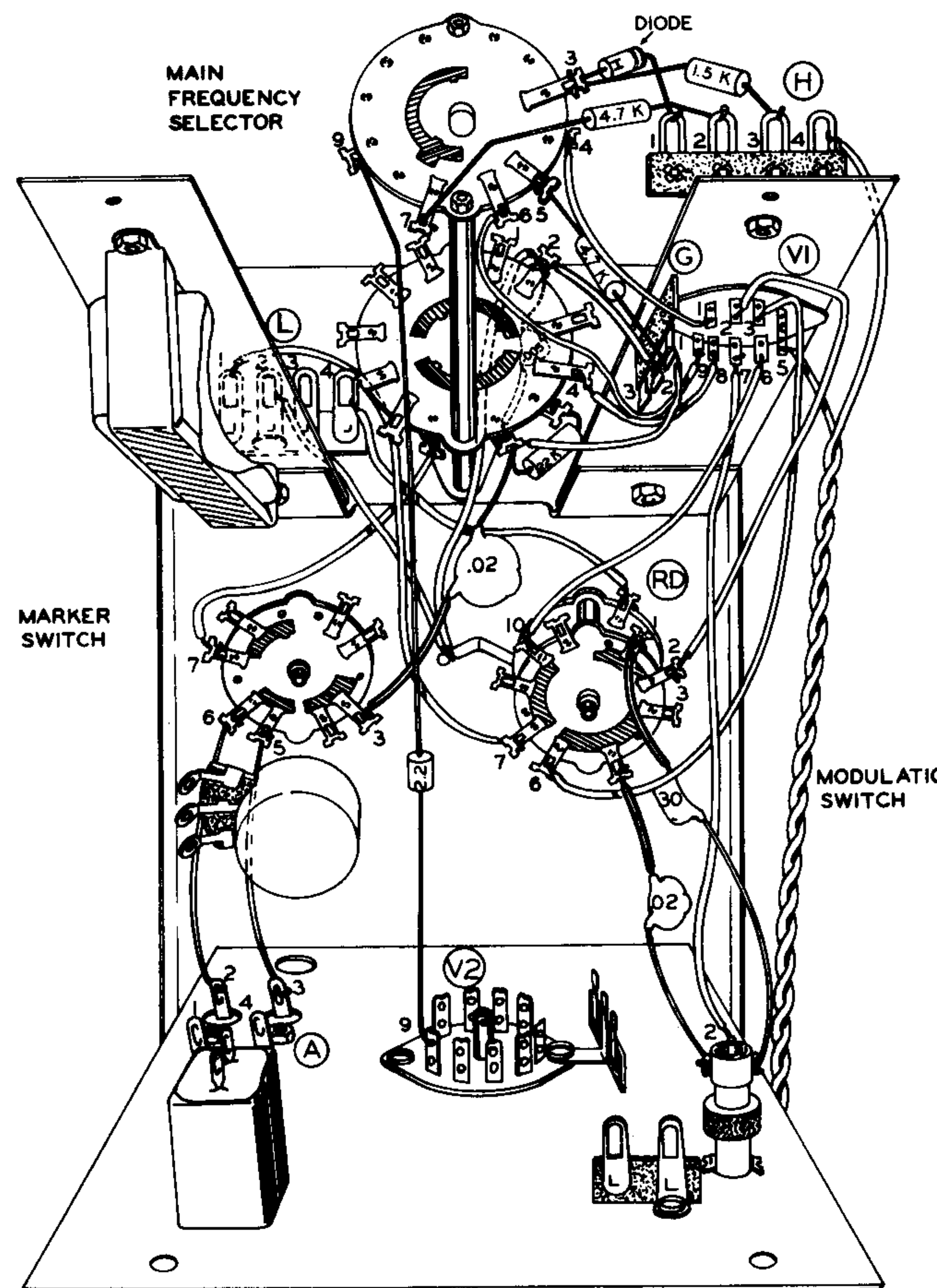

Figure 12

(✓) Route the wire from lug 9 of socket V1 between the chassis and the 5.6 K $\Omega$  resistor and around terminal strip G; connect this wire to lug 6 of wafer RD on the Frequency Selector switch (S-1).

(✓) Connect the loose end of the wire coming from lug 10 of wafer RD on the MODULATION switch to lug 6 of socket V1 (S-1).

(✓) Connect the wire coming from lug 7 of socket V1 to lug 2 of the 100 kc oscillator coil (S-1).

(✓) Connect the free end of the wire coming from lug 2 of wafer RD on the MODULATION switch to lug 2 of socket V1 (S-2).

(✓) In a similar manner, connect the wire from lug 6 of wafer RD on the MODULATION switch to lug 3 of socket V1 (S-1).

(✓) Connect the shorter wire of the twisted pair to lug 5 of socket V1 (S-3).

(✓) Connect the longer wire of the twisted pair to lug 4 of terminal strip H (S-3). Dress this twisted pair up along the panel, then back along the edge of the oscillator subchassis.

(✓) Select a 1.5 K $\Omega$  resistor (brown-green-red) and connect it between lug 3 of terminal strip H (S-4) and lug 3 of wafer RD on the Frequency Selector switch (NS).

- (✓) Similarly, connect a 4.7 K $\Omega$  resistor (yellow-violet-red) between lug 2 of terminal strip H (S-3) and lug 7 of wafer RD on the Frequency Selector switch (S-2).
- (✓) Connect the sweep diode between lug 1 of terminal strip H (NS) and lug 3 of wafer RD on the Frequency Selector switch (NS). Make certain the polarity is correct, with the cathode end toward lug 1 of terminal strip H. Now, carefully solder this lug (S-3). Use care to avoid overheating the diode. It helps to hold the diode lead lightly with long-nose pliers. This acts as a "heat sink", and dissipates the heat before it reaches the diode. Place a small "blob" of solder on the top of the terminal strip lug, then grip the diode lead with the pliers and apply more heat to flow the solder. Continue holding the lead until the joint is cool to the touch.
- (✓) In the same manner, solder lug 3 of wafer RD (S-3).
- (✓) Locate the 2.2  $\mu\mu\text{f}$  tubular phenolic capacitor. This component looks like an extremely short resistor, and bears color markings as follows: red-red-white.
- (✓) Connect this capacitor between lug 9 of wafer RD on the Frequency Selector switch (S-1) and lug 9 of the main chassis plate tube socket V2 (S-2).

This completes the wiring of the oscillator subchassis and Frequency Selector switch. It would be advisable to recheck the steps up to this point; check the solder connections, check for short circuits between component leads and reposition any leads or components where shorts may exist. The final assembly pretty well closes up the chassis to a good inspection, so this is the time to catch and correct any wiring errors.

#### REACTOR SUBCHASSIS

- (✓) Mount the reactor on the subchassis with the leads adjacent to the notch in the subchassis as shown in Figure 13. Include a 2-lug terminal strip K on top of the subchassis, with a lockwasher under the mounting foot, and orient as shown. Use 6-32 hardware.
- (✓) Mount a 4-lug terminal strip L in the position indicated. Once again, use a lockwasher under the mounting foot.
- (✓) Connect a .005  $\mu\text{fd}$  disc capacitor between lugs 3 (NS) and 4 (NS) of terminal strip L as shown in Detail 13A.
- (✓) Cut the red reactor lead to length, and connect it to lug 3 of terminal strip L (NS). Dress this lead along the subchassis edge to the terminal strip, then over to the proper lug.
- (✓) Cut the yellow lead to proper length and connect it to lug 2 of terminal strip K (NS).
- (✓) In a similar manner, connect the black lead to lug 1 of terminal strip K (NS).
- (✓) Connect a .04  $\mu\text{fd}$  tubular capacitor between lug 3 of terminal strip L (S-3) and lug 2 of terminal strip K (S-2). Lay the body of the capacitor against the subchassis.

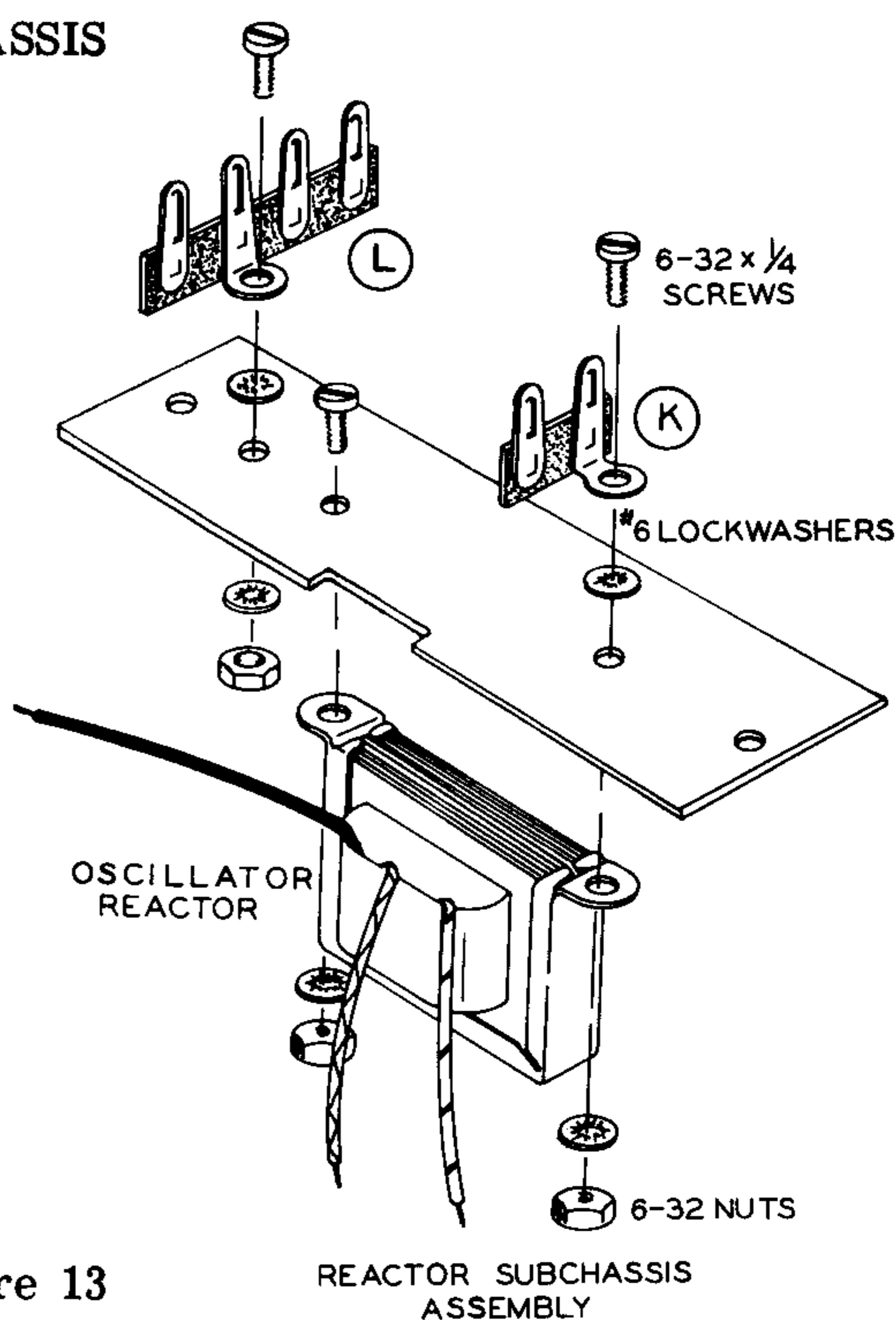
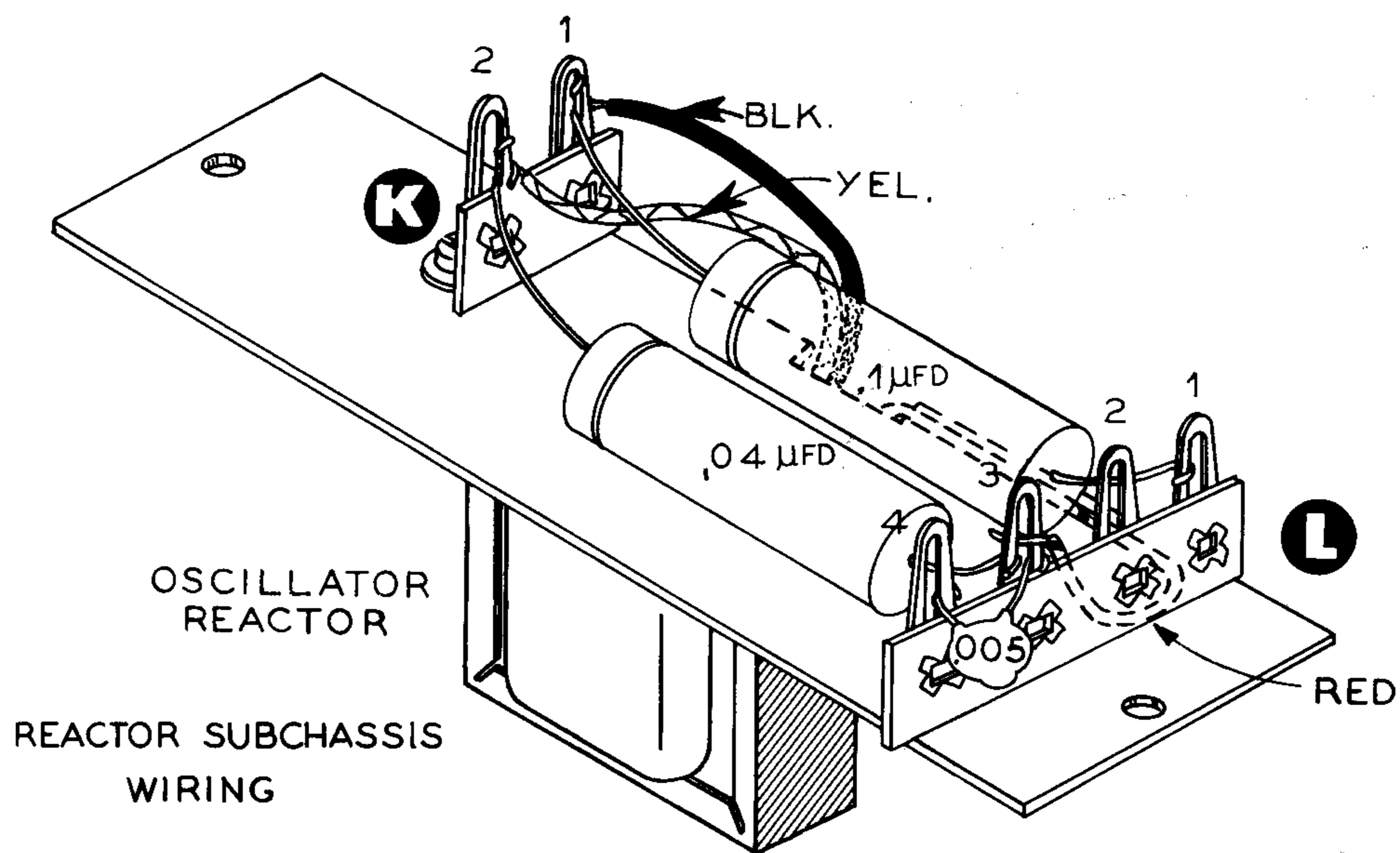

Figure 13

REACTOR SUBCHASSIS ASSEMBLY



Detail 13A

(✓) In the same way, connect a .1  $\mu$ fd tubular capacitor between lug 1 of terminal strip L (NS) and lug 1 of terminal strip K (S-2).

(✓) Dress the two leads from the MODULATION switch and the lead from the MODULATION switch ground lug up between the left flange of the subchassis support bracket (as viewed from the rear of the instrument) and the Frequency Selector switch.

(✓) Mount the reactor subchassis in position with 6-32 hardware. If necessary, again refer to Figure 10 on Page 27.

(✓) Connect the wire coming from lug 7 of wafer RD on the MODULATION switch to lug 1 of terminal strip L (S-2). See Figure 12 on Page 29.

(✓) Connect the wire coming from the MODULATION switch ground lug to lug 2 of terminal strip L (S-1).

(✓) Connect the wire from lug 1 of wafer FD on the MODULATION switch to lug 4 of terminal strip L (S-2).

Once again, check over your work to insure accuracy of wiring and quality of solder joints.

This completes the wiring of the instrument.

(✓) Place the back plate into position, and secure with 6-32 hardware. See Figure 10 on Page 27.

(✓) Install the knobs on the control and switch shafts. Note: Do not overtighten the larger of the concentric knobs. To do so will result in a collapse of the shaft wall with resultant drag on the level control shafts.

(✓) Insert the crystals as follows: 10 mc crystal in the outer socket; 10.7 mc crystal in the inner socket (next to tube socket).

(✓) Install the two 6U8 tubes in their sockets.

## PREPARING THE CABINET

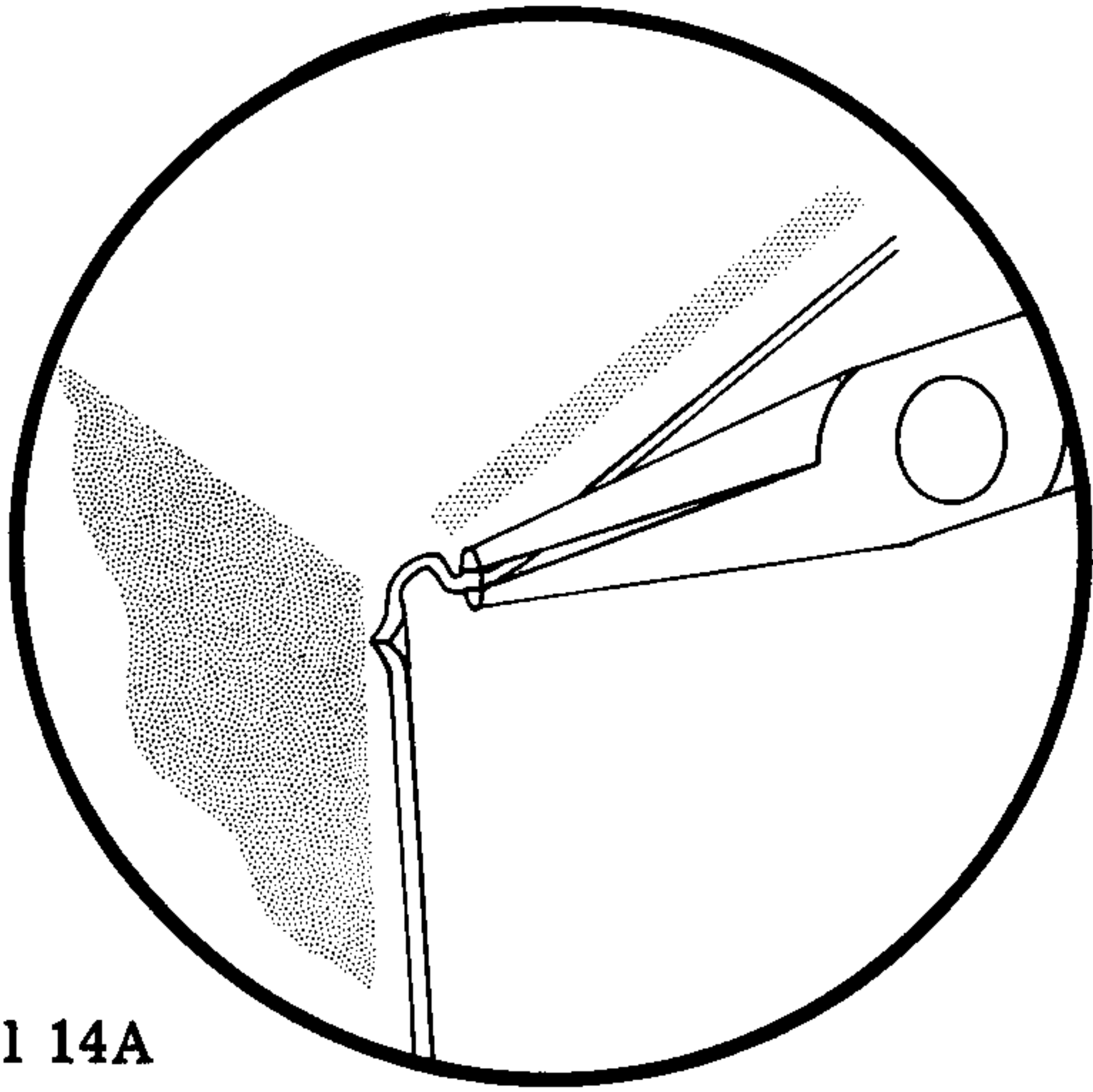

Detail 14A

- ( ) Run a #10 screw into and out of the handle holes to cut threads.
- ( ) Using the #10 screws, secure the handle to the cabinet. Refer to Figure 14.
- ( ) Insert the four rubber feet into the appropriate holes in the cabinet bottom.
- ( ) Very carefully, bend out just the tip of the flange ends at the cabinet corners, to "bite" into the panel. This insures a good electrical connection between the cabinet and panel, for a maximum shielding effect. Refer to Detail 14A.

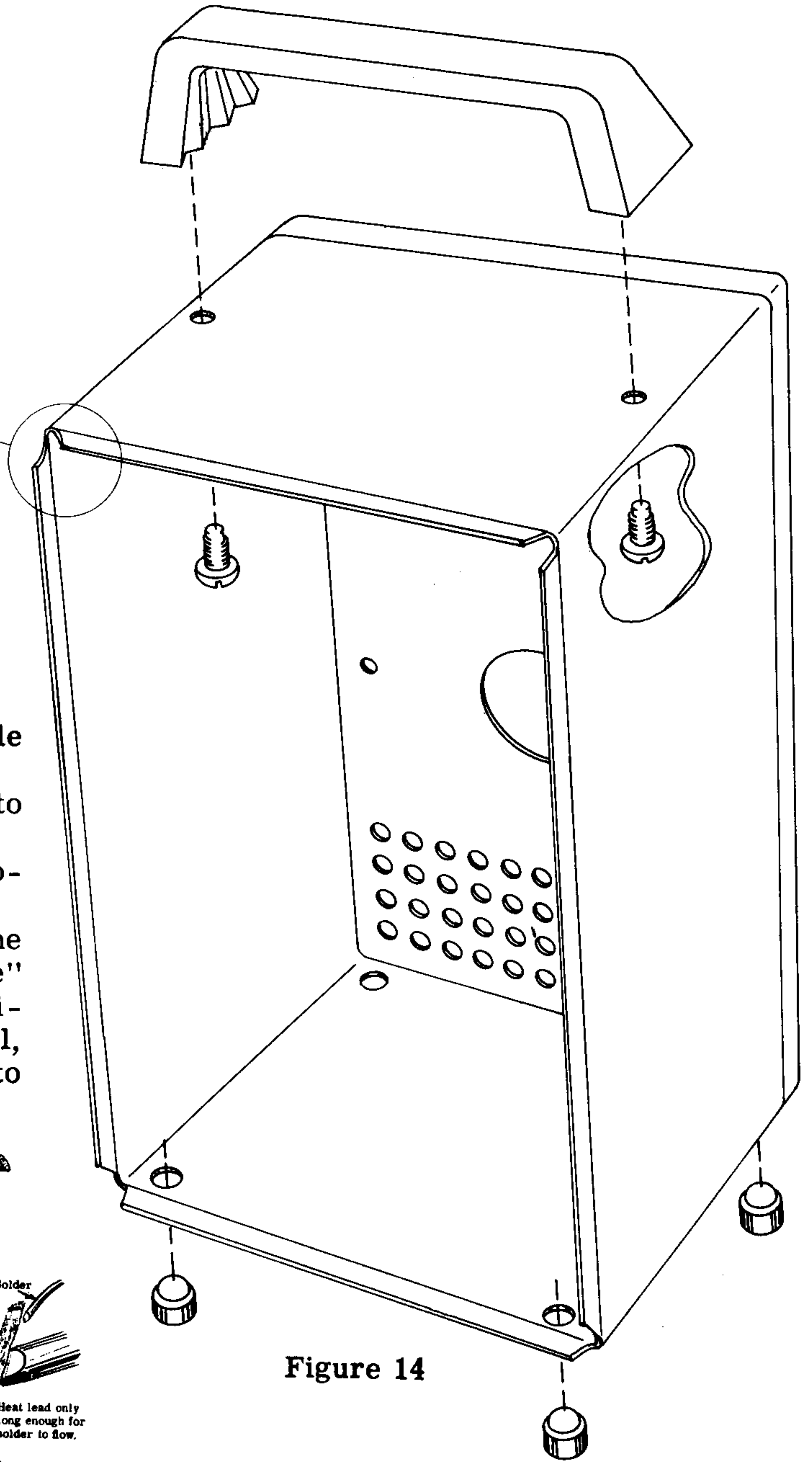
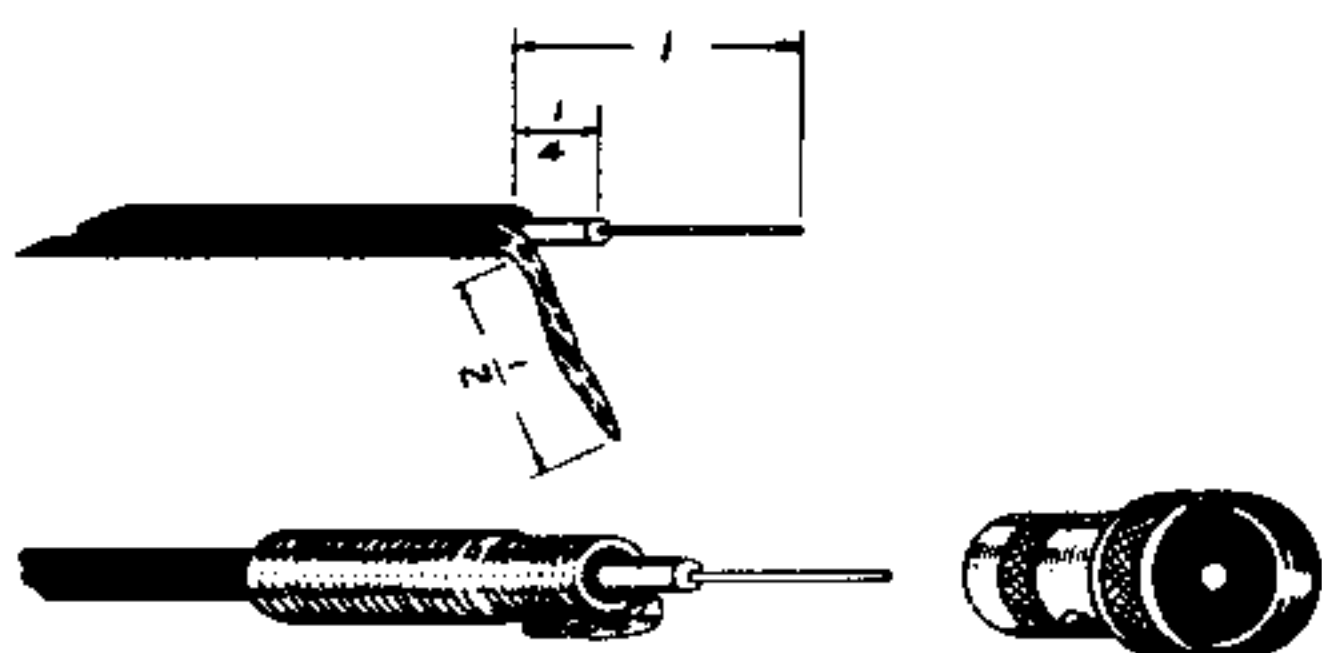
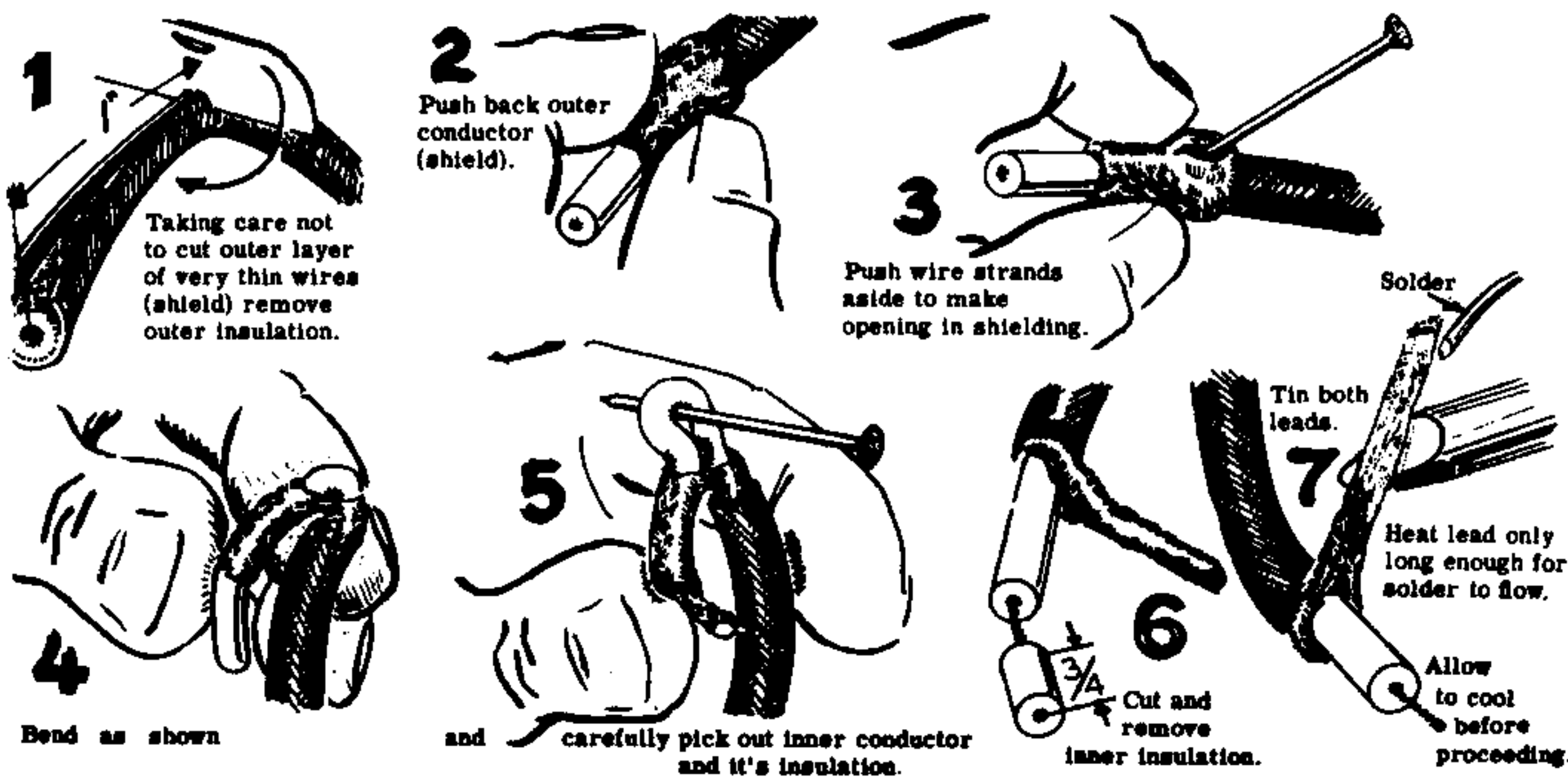

Figure 14



TIGHTEN SETSCREW

TRIM OFF EXCESS WIRE AND SOLDER CONNECTION.

Figure 15

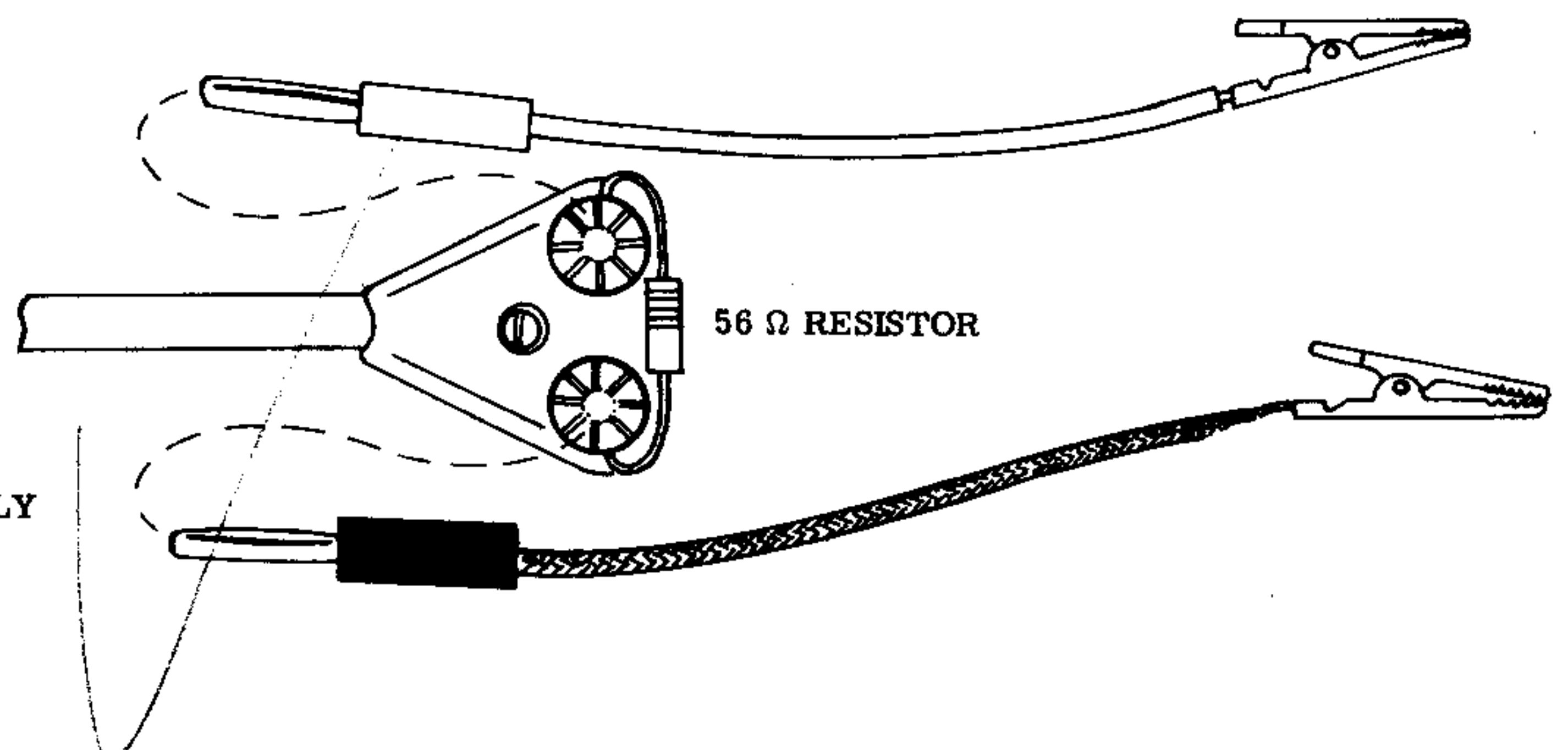
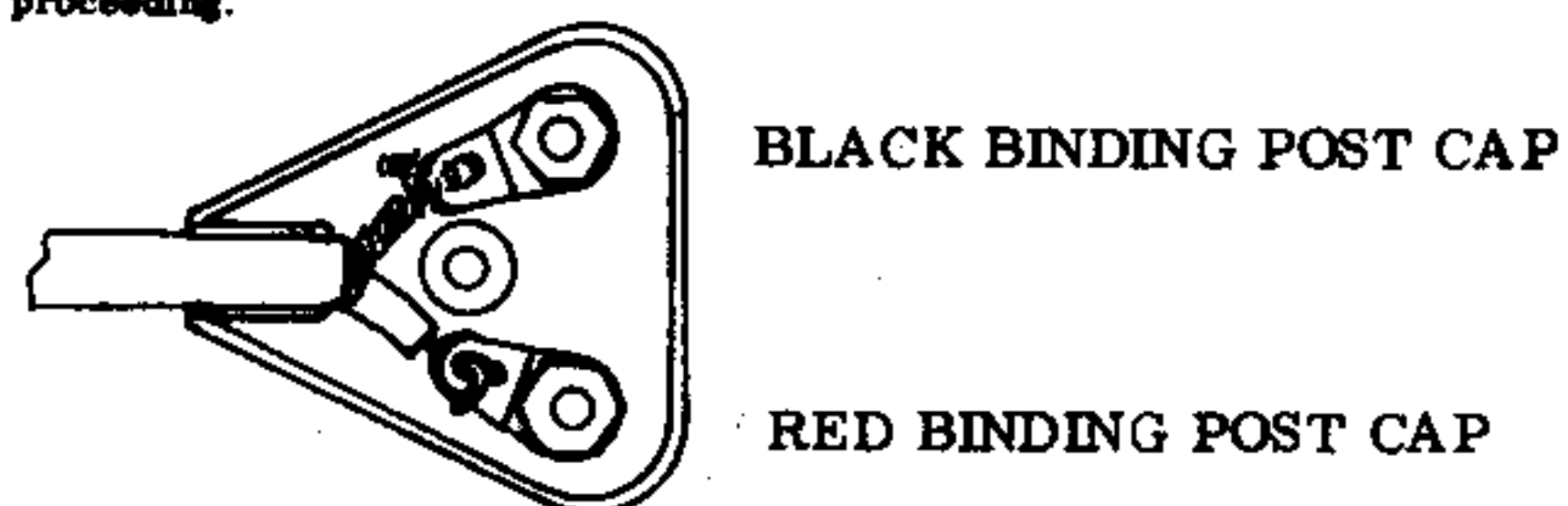

TEST CABLE ASSEMBLY



## TEST CABLE

- (✓) Following the procedure outlined in Figure 15, attach the cable connector to one end of the shielded cable.
- (✓) At the other end, prepare as follows:

Carefully strip the outer insulation about 5". In the manner previously outlined, extract the center conductor from the shield braid. Pull the braid tight by running a thumb nail along it and applying tension simultaneously.
- (✓) Cut off the braid and center conductor 3/4" from the end of the outer insulation. (Do not discard the remaining pieces.) Strip the insulation from the center conductor 1/4".
- (✓) Prepare the test cable pod by mounting two binding posts on the terminal half-shell with the holes in it. Use #6 solder lugs and 6-32 nuts on the inside.
- (✓) Install the red and black binding post caps.
- ( ) Connect the center conductor of the shielded cable to the red binding post solder lug (S-1).
- (✓) Similarly, connect the braid to the solder lug on the black binding post (S-1).
- (✓) Assemble the terminal half-shells with a 6-32 x 1/2" round head screw and nut. Make certain the cable is properly clamped, with a little slack between the clamping point and solder lugs.
- (✓) Strip both ends of the piece of center conductor previously cut off, back about 3/8". Tin the ends.
- (✓) Connect an alligator clip to one end, by bending over the "ears" of the clip to clamp the wire. Solder the lead to the clip.
- (✓) Slide a red banana plug cap over the lead and attach a banana plug to the opposite end. Do this by inserting the exposed wire end into the plug so it comes out of the small hole at the base of the threads. Wrap the wire around the shoulder of the plug and screw the cap down securely.
- (✓) Install the banana plug and alligator clip on the braid in the same manner the center conductor lead was prepared. It is necessary to twist the braid quite tightly to get it through the hole in the side of the plug.
- (✓) Install a 56  $\Omega$  resistor (green-blue-black) between the binding posts, and insert the banana plugs into the tops of the posts (center conductor lead into the red and the braid into the black).

The instrument is now ready for preliminary testing, prior to calibration.

## PRELIMINARY CHECKS

With an ohmmeter:

- (✓) Turn the SWEEP WIDTH control maximum counterclockwise to turn off the AC power switch. Measure the resistance between prongs on the power plug; it should be infinite (an open circuit).
- ( ) Now check the resistance between each prong on the power plug and the chassis; this, too, should be an open circuit.

- ( ✓ ) Turn the AC power switch on, and again measure the resistance between prongs; it should be in the neighborhood of 50 ohms. An open circuit should still exist between the prongs and chassis.
- ( ✓ ) Measure the resistance between lug 2 (label side) of the rectifier and the chassis; with all knobs turned maximum counterclockwise, the meter should indicate a low resistance value which begins to increase as the capacitors charge. The reading should level off at not less than 100 K ohms. (In most cases, it will be closer to 1 megohm.)
- ( ✓ ) Now turn the MARKER oscillator switch one position clockwise; the reading should drop to somewhere around 50 K ohms.

Without an ohmmeter:

- ( ) With no ohmmeter available, a thorough, point-by-point visual inspection is necessary. First, check the line cord filter on terminal strip J for short circuits between component leads or component leads and the lugs. Make sure that the filter chokes do not touch the chassis.
- ( ) Check the power supply wiring; be especially critical around terminal strip D.
- ( ) Inspect all B+ terminals in the instrument:
  - MODULATION switch, lug 4 of wafer RD.
  - Tube socket V2, lug 1.
  - Terminal strip E, lug 1.
  - MARKER oscillator switch, lug 7.
  - Marker oscillator LEVEL control, lug 2.
  - Main Frequency Selector switch, lugs 5, 6, and 7 of wafer FD.
  - Terminal strip G, lug 1.
- ( ) Check for possible short circuits caused by bits of wire or solder, or by socket or terminal strip lugs with too much solder.

If either form of inspection has disclosed no abnormality, proceed with the testing as follows:

- ( ✓ ) Turn all switches and controls to their full counterclockwise position.
- ( ✓ ) Plug the line cord into a source of 105-125 V AC, 50 or 60 cycle only. **WARNING:** Do not attempt to operate this instrument on DC; the instrument will not function and severe damage to the power supply is likely to result.
- ( ✓ ) Turn the SWEEP WIDTH control clockwise to activate the AC power switch. The neon pilot lamp should light immediately, and should remain lit as the tubes warm up. This, together with the tubes heating up normally, is indicative of proper power supply operation.
- ( ✓ ) Connect the test cable to the instrument. Unhook one end of the terminating resistor at the end of the cable (across the binding posts), and turn the RF-AF switch to the AF position. (As was previously stated, this switch simply selects the source impedance of the instrument; in the AF position, this impedance is relatively high. In instances where more RF output is desired, turning the switch to the AF position is all that is necessary.)
- ( ✓ ) Clip the test lead to the antenna terminals of an FM tuner or receiver in working condition. Turn the OUTPUT control maximum clockwise.

- (✓) Turn the MARKER oscillator switch to the 10.7 mc position and advance the LEVEL control (the red knob) full clockwise. Some quieting should be evident, due to direct radiation of the signal into the receiver's IF system. Now, tune the receiver to around 107 mc (the 10th harmonic). Definite quieting should be noticed as the receiver is tuned across the signal. A similar signal should be found at 96.3 mc (the 9th harmonic of 10.7 mc).
- (✓) Turn the MARKER oscillator switch to the 10.0 mc position. Signals should be received at 90 mc and 100 mc.
- (✓) Turn off the MARKER oscillator and turn the Main Frequency Selector to the 10.7 mc sweep position. Advance the SWEEP WIDTH control fully. A very distinct buzz should be heard, due to the radiation of an IF signal containing 60-cycle blanking and sweep.
- (✓) Advance the Frequency Selector switch to the 100 mc position and tune the receiver around that spot on the dial. A point should be found at which almost complete quieting occurs. It may not be at 100 mc on the dial, but this situation will be corrected during the calibration procedure. Now turn the MODULATION switch to 400 ~ MOD and advance the LEVEL control fully clockwise. A tone should be heard. Occasionally above normal output is obtained from the MODULATION oscillator, which can cause over-modulation. If this is the case, simply reduce the LEVEL control setting slightly.

If the tests up to this point have checked out right, it is safe to assume the instrument is functioning properly. Continue on to the calibration procedure.

#### CALIBRATION

Preliminary calibration will consist of only a rough approximation of the final adjustments, which will be made with the instrument in its case and "aged" somewhat.

- (✓) Begin the preliminary calibration by switching on the 10.0 mc marker crystal and locating the signal around 100 mc on the receiver dial (assuming the receiver dial is fairly accurate; if in doubt, verify its accuracy by hooking up an antenna and tuning in a station of known frequency near the center of the band). Switch the MARKER oscillator off and on again, to verify the signal. Note the position of the receiver dial pointer.
- (✓) Now, switch on the 100 mc oscillator and tune in the signal on the receiver. Note the dial pointer position. Using the alignment tool supplied, adjust the 100 mc coil to approximately the same point on the dial occupied by the MARKER oscillator. Note the direction the coil slug is moved to effect this tuning. Do not be concerned with zero-beating the signals at this time.
- (✓) Tune in the MARKER oscillator signal at about 90 mc on the receiver dial. Note the exact dial reading. Switch the high frequency oscillator to the 90 mc position and locate this signal. If no signal is found, and the 100 mc signal was low in frequency, it is possible that the 90 mc oscillation is below the low end of the FM band. Turn the slug of the 90 mc coil in the same direction the 100 mc slug was turned, and continue searching with the receiver. When the signal is located, tune it to about the same point on the dial as the 10.0 mc MARKER oscillator harmonic.
- (✓) In the same manner, rough calibrate the 107 mc signal, using the 10.7 mc position of the MARKER oscillator switch.
- (✓) Switch the high frequency oscillator to the 10.7 mc sweep position and tune this coil for the loudest buzz from the speaker. This does not adjust this coil very closely, but it brings it close enough to view the band-pass of the IF system with an oscilloscope prior to final calibration.

The 100 kc submarker oscillator coil should not require adjustment to be sufficiently accurate. Adjustment of this coil is rather difficult, in that it requires equipment other than that already used and it is sometimes difficult to obtain a satisfactory indication. For the benefit of possible instrument servicing requirements in the future, a couple of workable procedures will be outlined.

Procedure 1 requires the use of a signal source of known accuracy, such as a signal generator which covers 100 kc or 200 kc or an audio oscillator capable of 50 kc or 100 kc, and an oscilloscope.

Connect the signal source to the oscilloscope X-axis (horizontal) input, and the FMO-1 to the Y-axis (vertical) input. Turn the MODULATION switch to 100 kc OUT (the RF-AF switch should be on AF). Set the signal source to the frequency which will be used, and adjust the 100 kc coil for the appropriate Lissajous pattern. Using this method, waveform distortion may make identification of the patterns difficult.

Procedure 2 requires an AM broadcast receiver and some type of crystal diode. Tune the receiver to a broadcasting station on a multiple of 100 kc (such as 700 kc, 1000 kc, 1400 kc, etc.). Connect the FMO-1 test cable ground to the chassis (through a .01  $\mu$ fd capacitor, if the receiver is an AC-DC type), and the "hot" lead through the diode to the antenna terminal. Adjust the 100 kc coil for zero-beat.

#### Final Calibration:

Install the instrument in its cabinet and secure it in place with the two 6-32 stove head screws. Plug the FMO-1 into the power outlet again and let it warm up in the cabinet for several hours, to give the components a chance to stabilize.

Run through the calibration procedure again, this time using more care. Tune the oscillator (90 mc, 100 mc, 107 mc) coils to zero-beat with the MARKER oscillator. The zero-beat sound is not unlike the TV receiver horizontal oscillator radiation into an AM radio. It will be practically impossible to set the coils to exact zero-beat, but when the sound described is heard, they will be close enough. The coil slugs may be reached through the holes in the back of the cabinet. Use the long, flexible end of the alignment tool; it may be "bent" into the coil slug if a cabinet hole is not in the right position.

The 10.7 mc sweep calibration procedure requires the use of an oscilloscope with provisions for line sweep, or a filament transformer (to feed a 60-cycle sine wave into the X-axis or horizontal channel input) for use with a scope without line sweep provisions. See Page 40.

Connect the oscilloscope to the grid of the last IF amplifier or limiter through a 100 K $\Omega$  resistor. Connect the FMO-1 to the grid of an IF amplifier, about two stages ahead of the oscilloscope connection (use the 56  $\Omega$  terminating resistor and the RF position of the RF-AF switch).

For oscilloscopes without line sweep provisions, see the OPERATIONAL section of this manual, Page 40.

Turn off the MODULATION and MARKER oscillator switches and switch the FMO-1 to 10.7 mc sweep. Set the SWEEP WIDTH control about halfway. Adjust the OUTPUT control and oscilloscope gain controls to obtain a trace of adequate height. It will probably look like this:

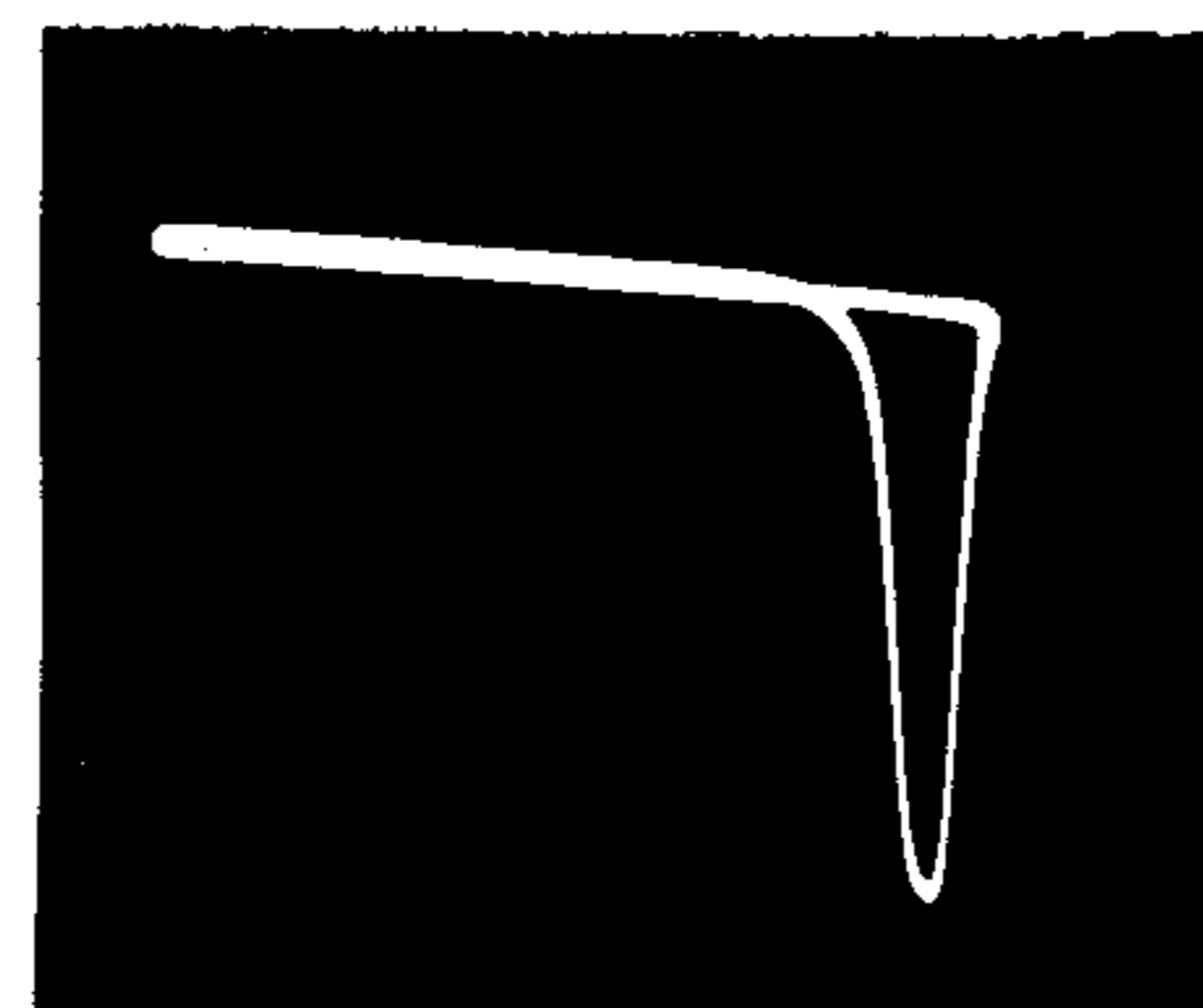

Adjust the 10.7 mc sweep coil to produce a pattern like this:

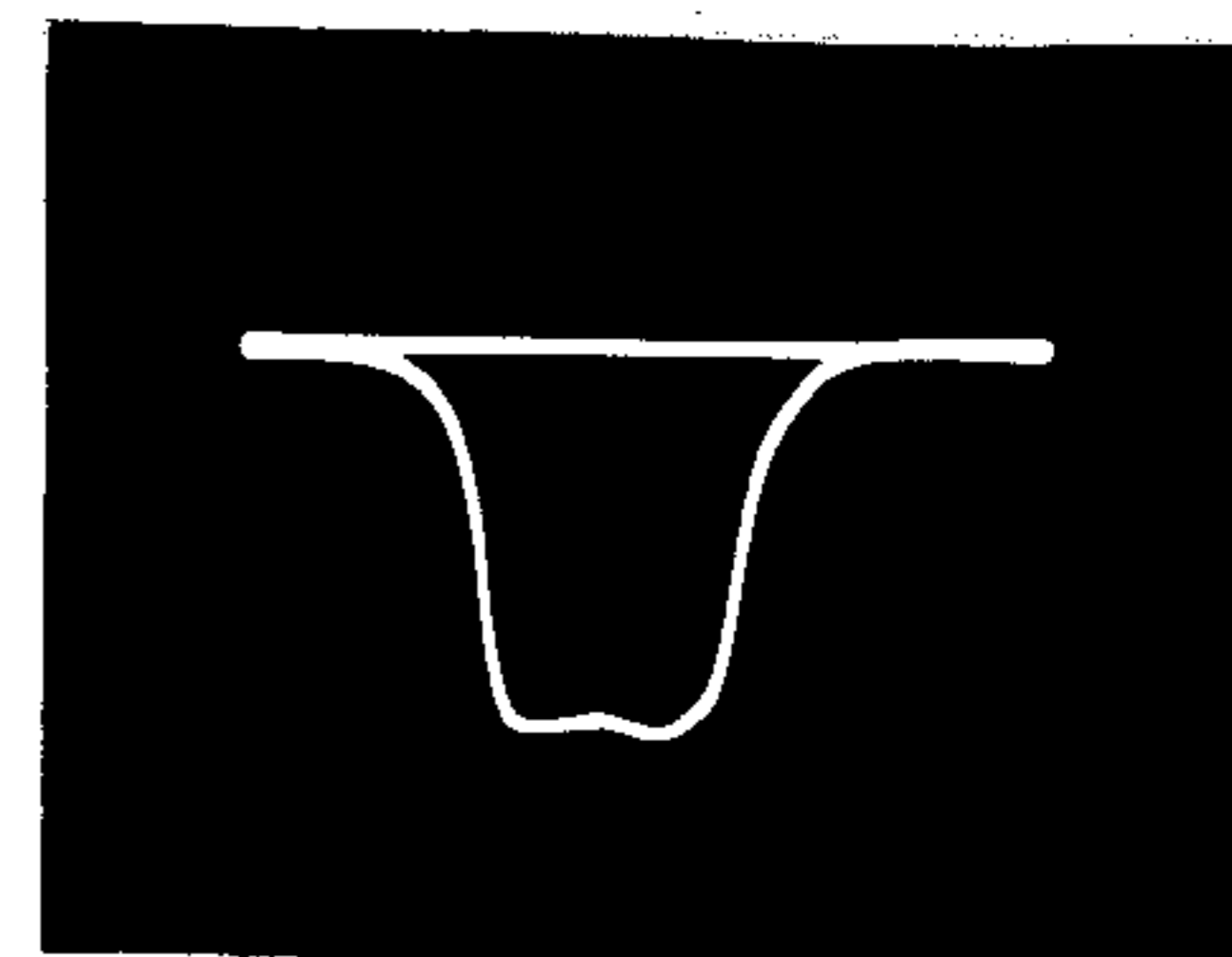

If the band-pass shows a tendency to flatten on one side, turn the oscilloscope phasing control to put the flat edge at the end of the base line, like this:

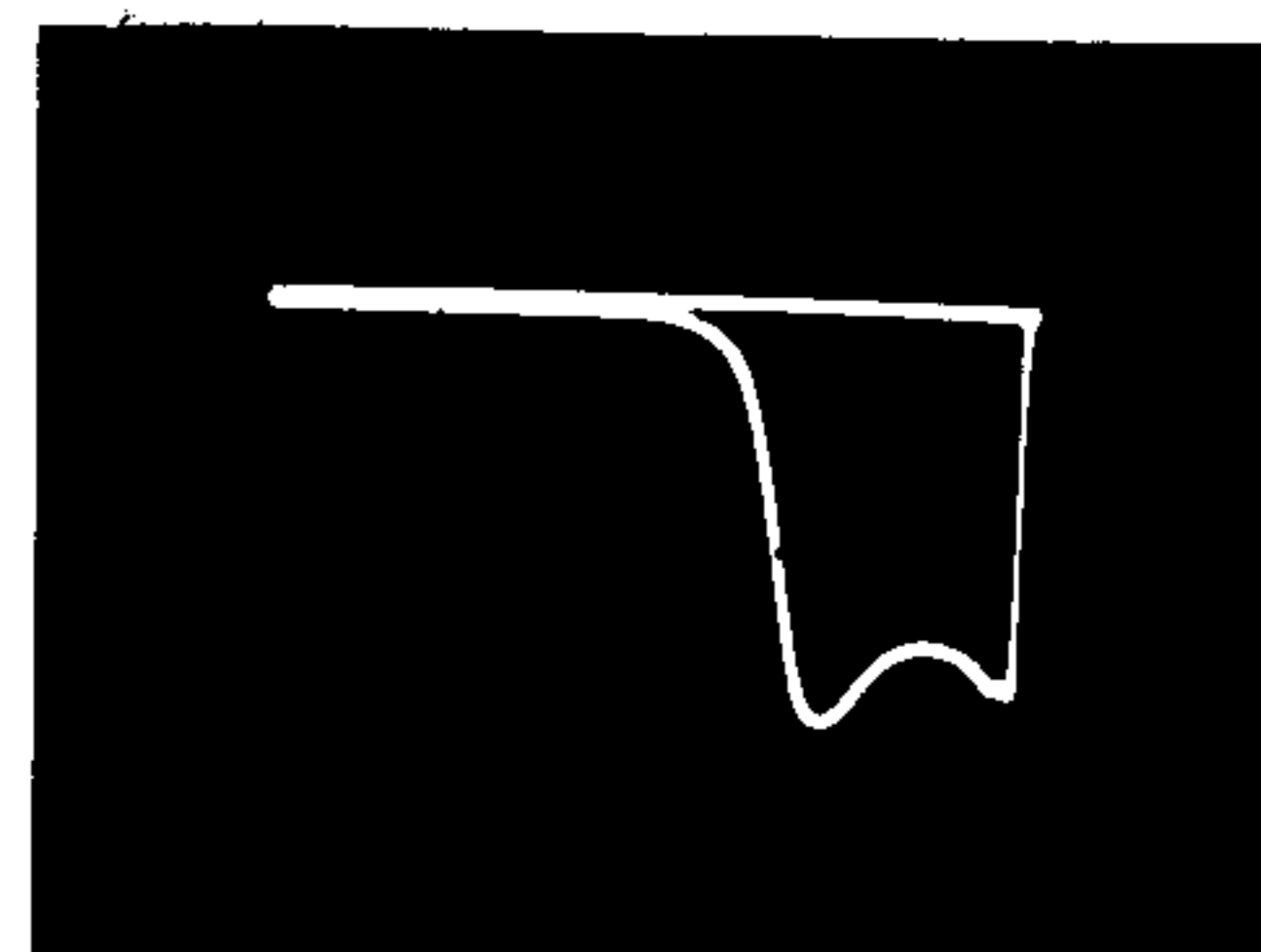

Readjust the coil to center the band-pass trace and add some 10.7 mc marker:

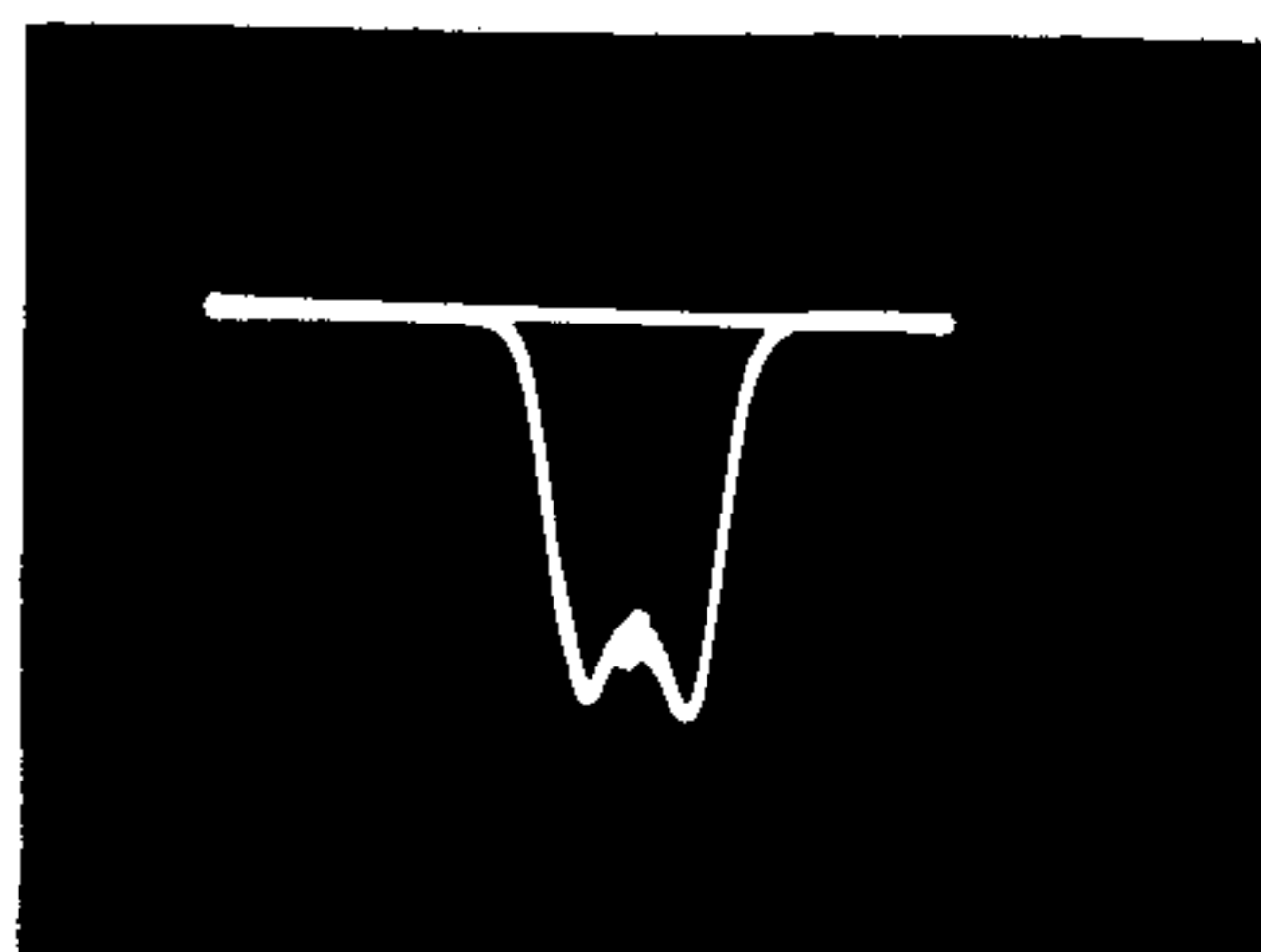

Turn the SWEEP WIDTH control to maximum counterclockwise (without turning off the instrument), and adjust the coil to center the marker. Advance the SWEEP WIDTH control fully and the pattern should show a narrow "spike":

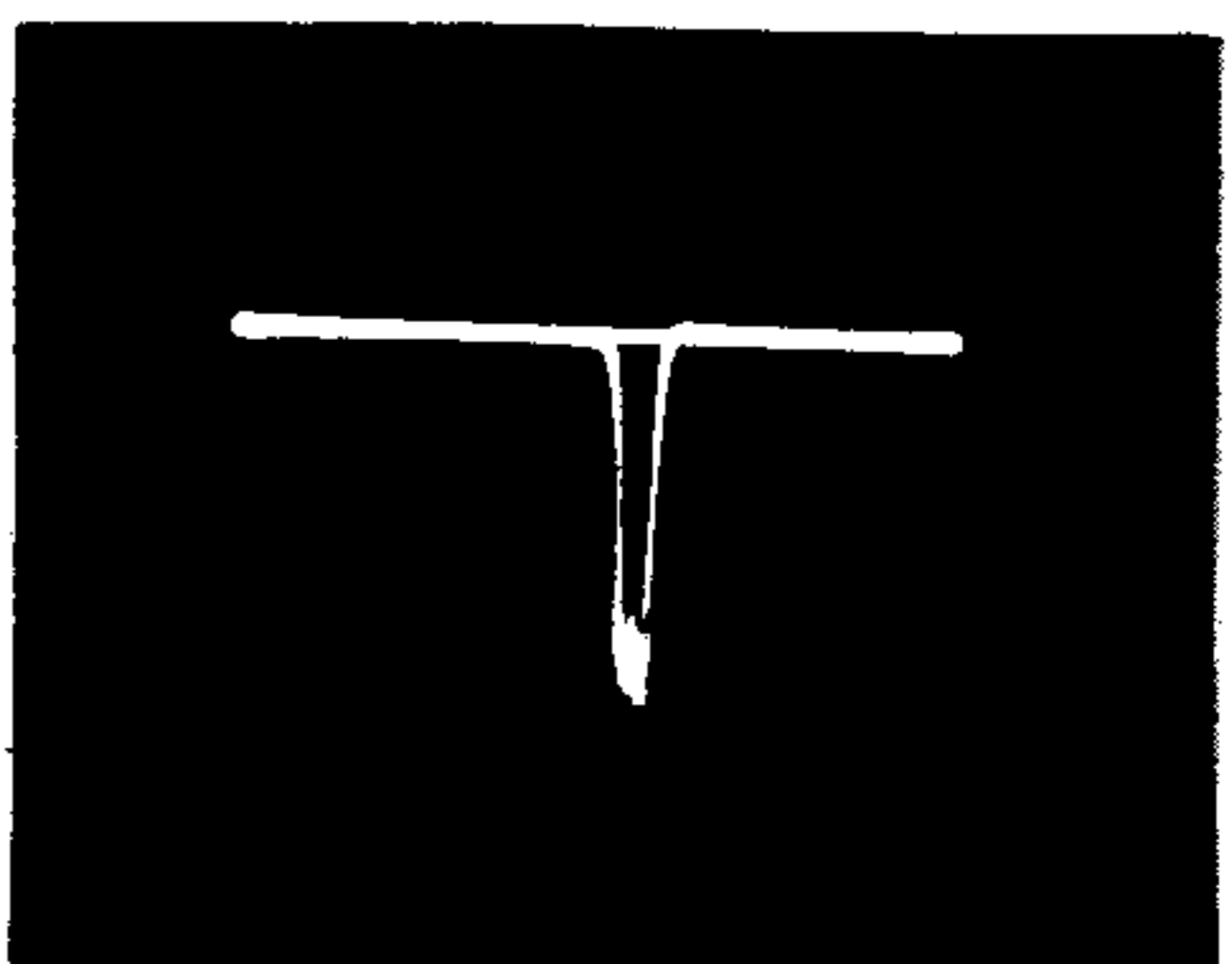

The 100 kc oscillator coil can only be adjusted with the unit out of the cabinet.

#### IN CASE OF DIFFICULTY.

If any of the circuits in the instrument fail to operate, the failure may be due to one of two things: First, incorrect or defective wiring and/or connections and second, a defective component.

The first step is to determine which circuits are causing trouble. If none of the circuits work, the cause probably lies in faulty solder joints or power supply wiring.

Assuming some of the circuits function properly, go over the wiring of the defective circuit closely. Often, it helps to have a friend check the wiring. Sometimes the most obvious mistakes are the hardest to find, due to familiarity on the part of the constructor.

Next, check the tubes.

If an intensive visual inspection fails to disclose the source of difficulty, further checks using a voltmeter are indicated. It is quite unusual to find a new component defective, but it does happen occasionally. Usually, however, the trouble can be traced to a wiring error or poor solder joint.

Reread the applicable section of the CIRCUIT DESCRIPTION and turn to the SERVICING section beginning on Page 46 of this manual.

## PART II OPERATIONAL SECTION USING THE INSTRUMENT

### INTRODUCTION

The FM tuner or receiver is basically the same as the ordinary AM superheterodyne receiver, except for the detector. The detector employed in FM has provisions for removing amplitude variations of the carrier, which may be accomplished by limiter stages preceding a discriminator, or by utilizing the inherent insensitivity to AM of the ratio detector. However, those circuits preceding the detector in an FM tuner or receiver differ only in operating frequency and bandwidth from the comparable circuits of the AM superheterodyne.

For this reason, many of the FM servicing techniques and problems are nearly identical with those of AM servicing. A thorough knowledge of AM receiver servicing should precede any attempt to learn the specialized problems involved in servicing FM tuners or receivers.

Receiving equipment complaints can be roughly divided into two rather broad categories:

- 1 - The tuner or receiver is completely dead.
- 2 - High noise level and distortion.

In the first case, essentially the same techniques used in AM servicing may be applied in locating the defective component. To this end, a brief example of servicing by "signal injection" is included in this manual.

As far as category number two is concerned, probably the most common cause of low sensitivity, noise and distortion is poor alignment. Alignment using the FMO-1 will be covered in another section of this manual.

#### Servicing by Signal Injection:

Taking a hypothetical situation, a customer brings in an FM receiver for servicing. The complaint is "it went dead all of a sudden". The technician assures himself that the tubes are all good, and determines the presence of B+ with a quick voltmeter check.

Using the 400 ~ OUT position of the MODULATION switch, the technician applies the audio signal across the volume control. A loud tone tells him that the audio section is functioning properly. If he had not heard the tone, he would have progressed toward the speaker with a stage-by-stage injection of the 400-cycle signal until he heard the tone, and then looked for the trouble in the stage just ahead of that point.

Since the audio is working properly, the technician applies a 10.7 mc signal from the FMO-1 (in the 10.7 mc sweep position) to the front of the IF section. A loud buzz signifies that the IF's are functioning.

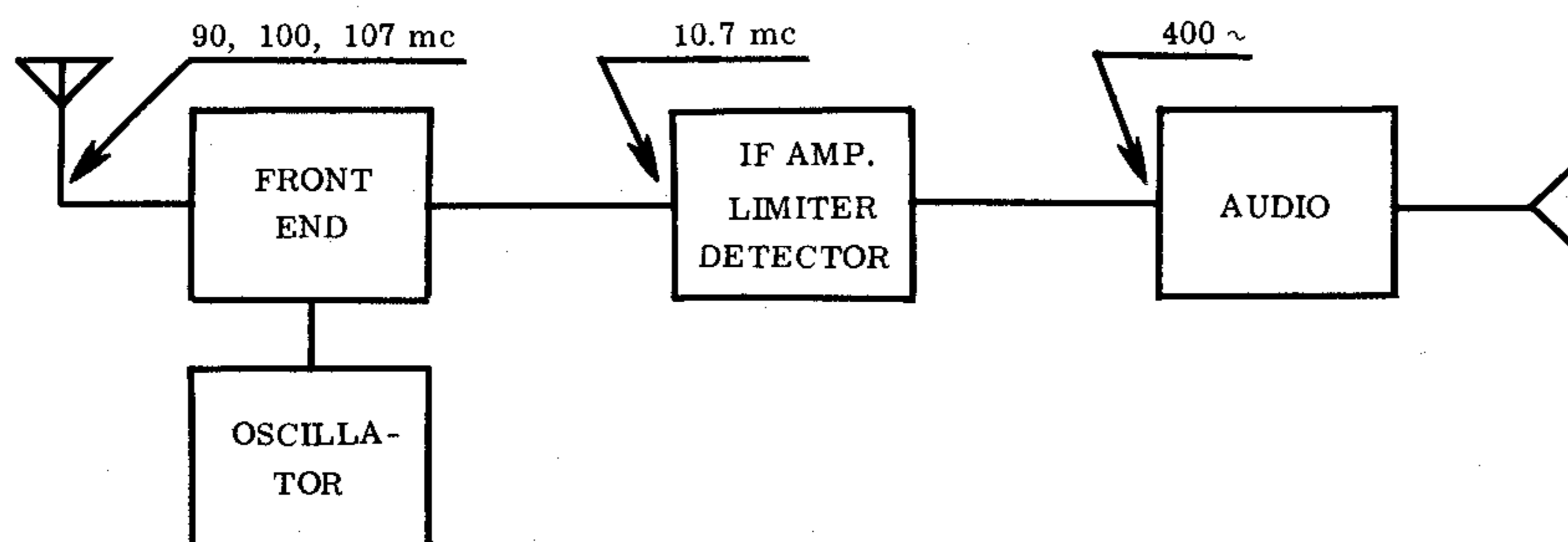

The signals so far have passed through the receiver to be heard from the loudspeaker, so the trouble must lie ahead of the IF's, somewhere in the "front end". The technician measures the grid bias on the local oscillator with a VTVM and finds no bias. From this, he concludes that the trouble must be in the local oscillator. Upon checking the other tube socket voltages, he finds no B+. A decoupling resistor has opened. Replacing the resistor restores the receiver to normal operation.

The hypothetical example used here embodies several important points:

1 - The use of signal injection servicing techniques depends on the technician. The information gained in section-by-section testing must be applied intelligently to stage-by-stage testing to locate the source of difficulty and take corrective steps. Dividing a tuner or receiver into the audio, IF and front-end sections allows testing of entire sections at one time, greatly simplifying the determination of where the trouble does not lie. The process of elimination is important in isolating a defective stage.

2 - When the section causing trouble is located, it is a simple matter to isolate the defective stage by checking each stage in the dead section.

3 - The local oscillator operation can be verified by measuring the grid bias voltage. Although it is sometimes possible to use the FMO-1 as a substitute local oscillator, the results are not consistent enough to warrant relying on this indication alone. It is better to check the bias voltage.

4 - The signal injected into a particular circuit must be the same frequency as that at which the circuit normally operates.

The FMO-1 can be a tremendous aid in normal, everyday servicing, as well as an alignment instrument. Its capabilities along this line are limited only by the user's ingenuity.

#### ALIGNMENT PROCEDURES

Wherever possible, refer to the manufacturers data for alignment procedures. When this information is not available, the following general methods may be found satisfactory.

#### METHOD I (Using sweep for IF's)

##### Material required:

One oscilloscope with line sweep provisions or  
Oscilloscope without line sweep and:

One center-tapped 6.3 V AC filament transformer  
One 250 K $\Omega$  control  
One .05  $\mu$ fd 400 V capacitor  
One .01  $\mu$ fd 400 V capacitor  
One 470 K $\Omega$  1/2 watt resistor

For  
phasing  
network

One 100 K $\Omega$  resistor (oscilloscope isolation)  
Two 120  $\Omega$  resistors (dummy antenna)  
One .05  $\mu$ fd 400 V capacitor (FMO-1 isolation)

The parts, if not already on hand, may be obtained at any electronic wholesale house or parts distributor.

The phasing network is needed only on those oscilloscopes without provisions for line sweep. This circuit is not the only one which will work, but is merely an example of one which has proven satisfactory.

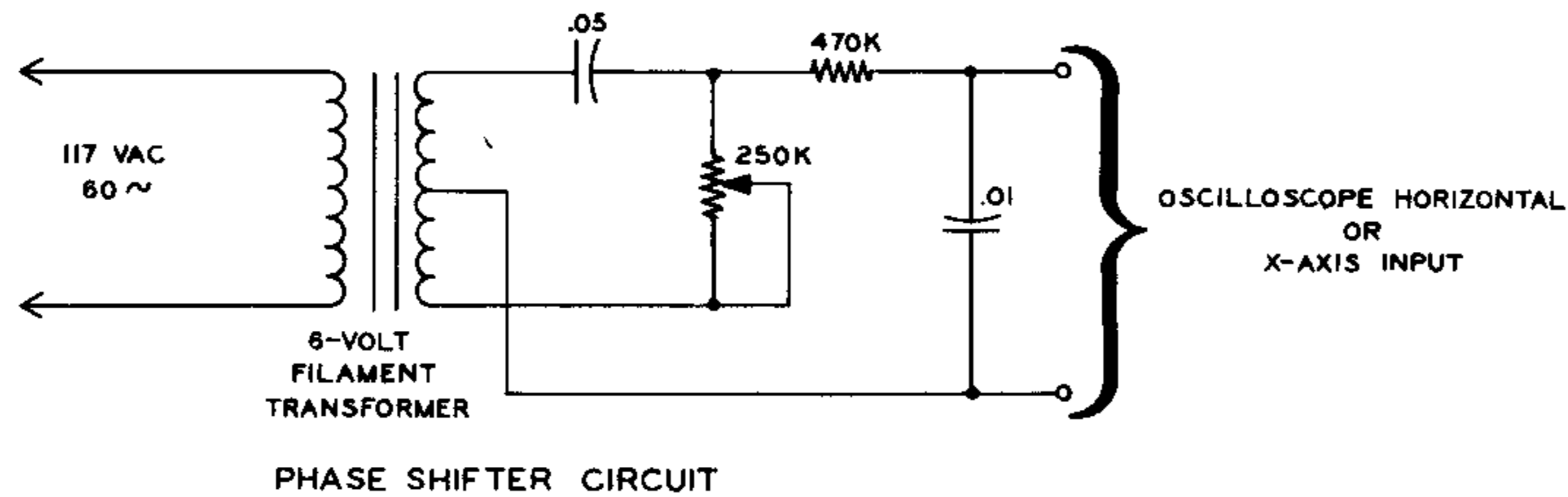

### IF Alignment:

Begin the alignment by connecting the oscilloscope vertical or Y-axis input across the grid resistor of the limiter circuit (if a discriminator and limiter are used), or across the negative end of the load resistor in the case of a ratio detector. The oscilloscope lead should be shielded, to prevent feedback and oscillation. The low side of the oscilloscope input should be connected directly to ground, and the high side connected to the previously mentioned points through a 100 KΩ resistor.

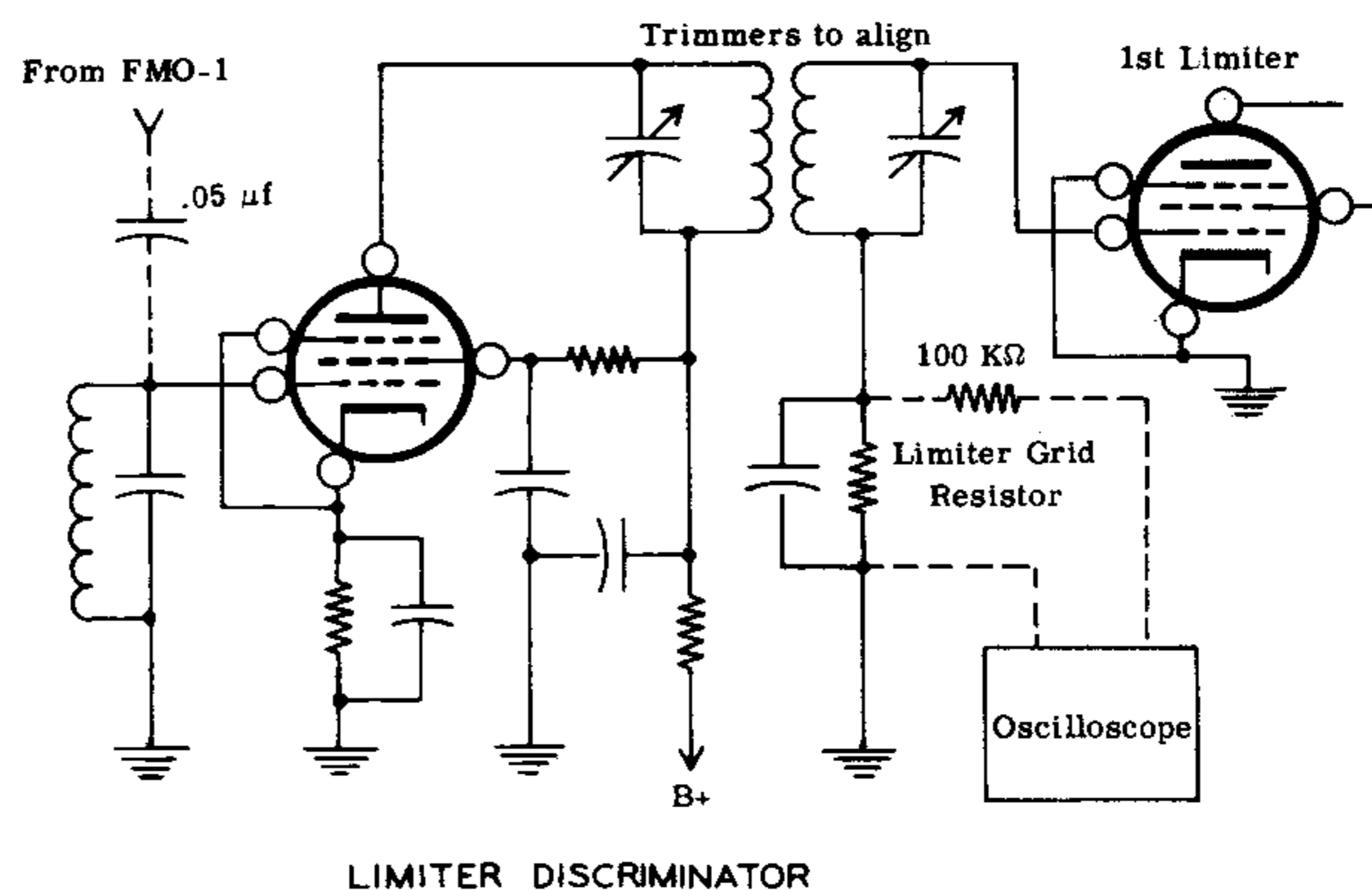
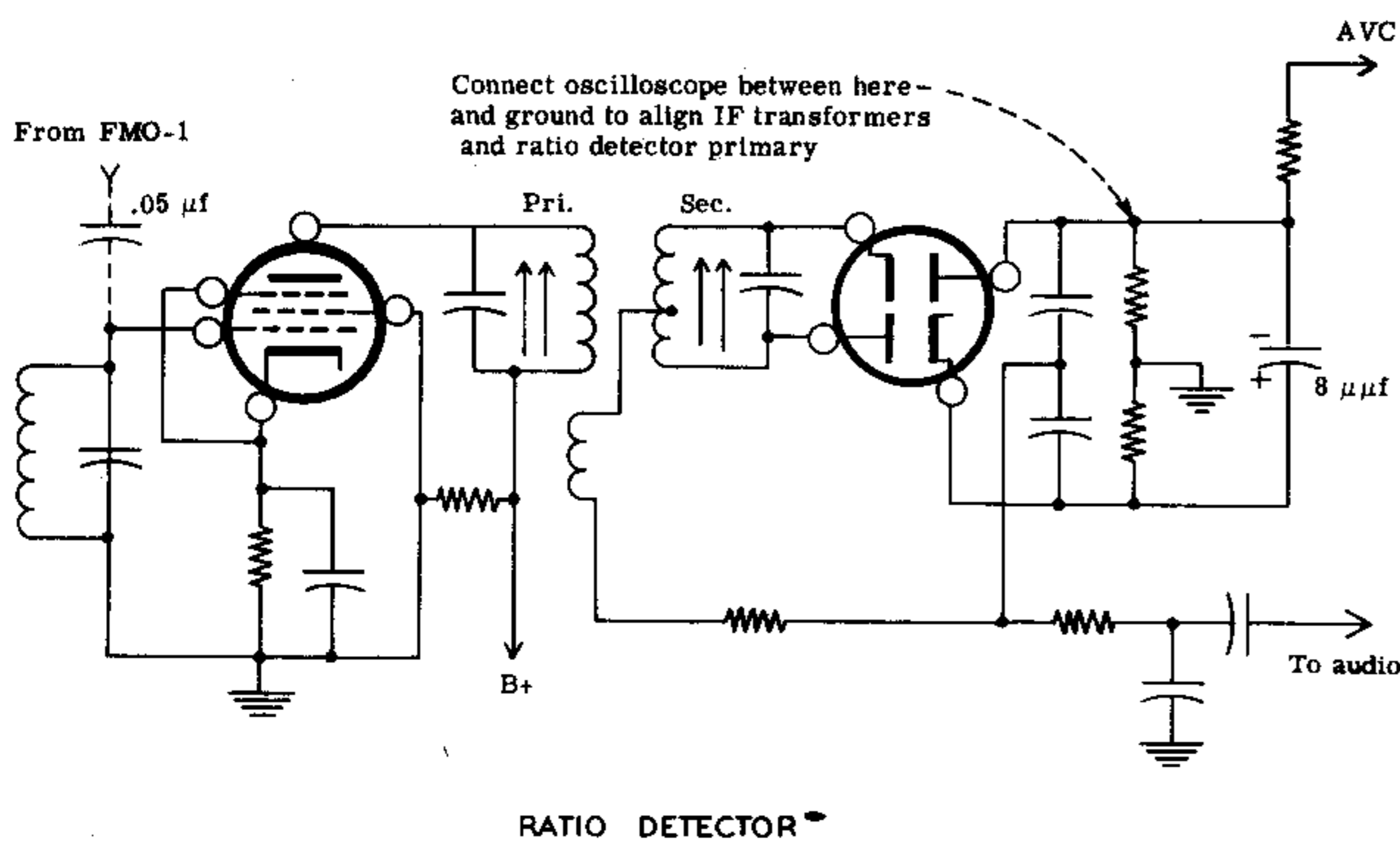

Connect the hot side of the FMO-1 through a .05 μfd capacitor to the grid of the preceding IF stage, and the low side to a ground close to this point.

Switch the oscilloscope to line sweep, or connect the phase shifter.

Turn on the 10.7 mc sweep in the FMO-1 and adjust the OUTPUT control and oscilloscope amplifier controls for the desired pattern height without overloading the IF amplifier. Adjust the phasing control to center the band-pass on the base line. Turn the MARKER oscillator switch to the 10.7 mc position and advance the marker LEVEL control. The band-pass waveform should begin to shrink as more marker is applied. Set the marker LEVEL for the minimum usable "pip" amplitude, to keep the waveform distortion to a minimum.

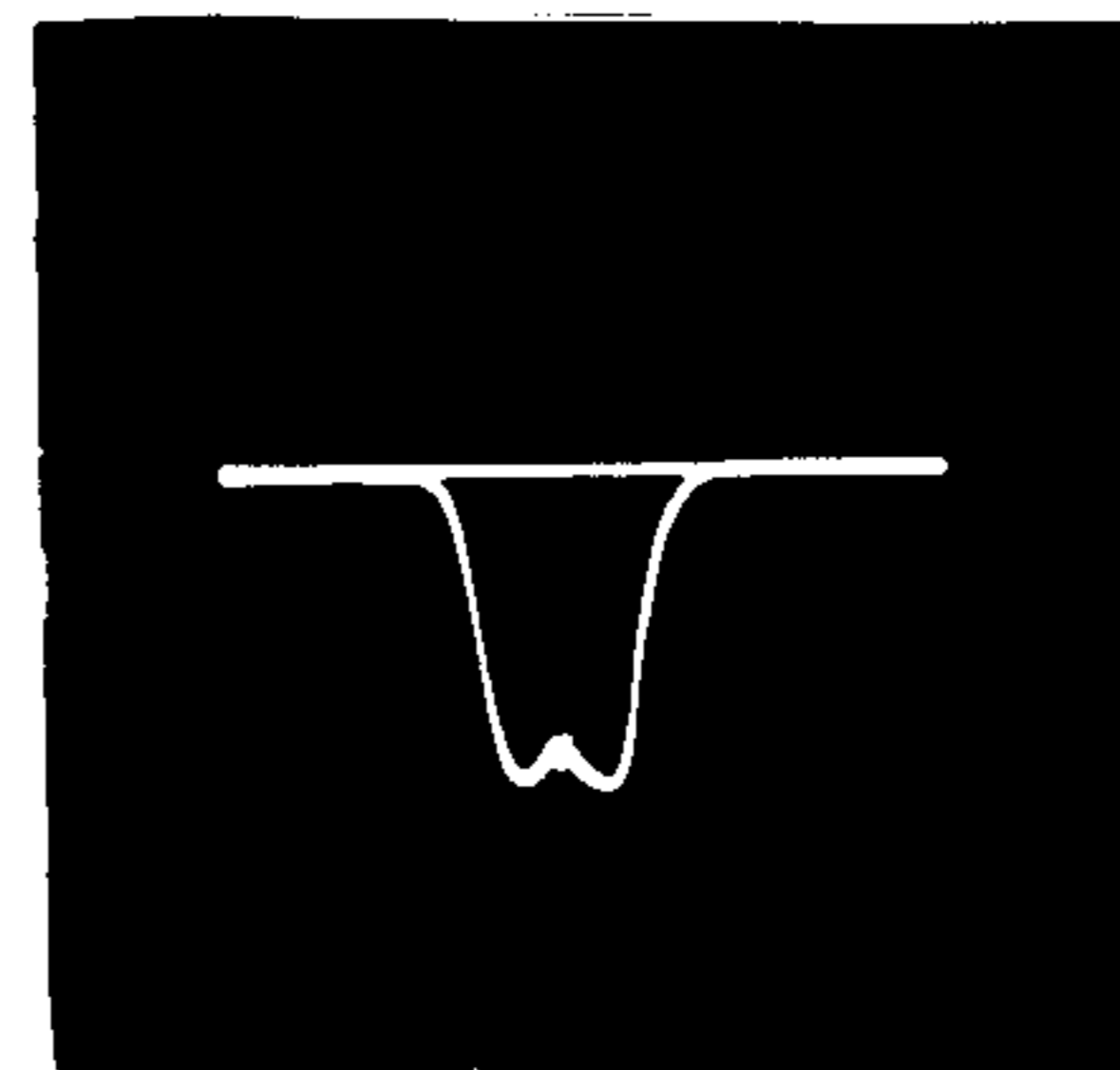

The last IF transformer, sometimes referred to as the limiter input transformer, is aligned by adjusting the primary and secondary trimmers or slugs for symmetry of the waveform on each side of the 10.7 mc center-frequency marker, consistent with the maximum amplitude obtainable.



Move the "hot" lead of the FMO-1 to the next IF amplifier grid, progressing toward the antenna. Reduce the output accordingly, and adjust the primary and secondary of the appropriate transformer for the best, flat-topped, symmetrical waveform possible. Turn on the 100 kc MOD and advance the modulation LEVEL control fully. Increase the setting of the marker LEVEL until the 100 kc "pips" are visible on each side of the 10.7 mc center frequency marker. Extremely severe waveform distortion will occur so note the location of these 100 kc "pips" as the marker LEVEL control is backed off. With a little practice, it is not difficult to tell where the "pips" would be on the undistorted waveform.



Continue on until all the IF's are aligned.

#### Detector Alignment:

The detector may be aligned by leaving the FMO-1 "hot" lead connected to the converter grid (where it was connected to align the first IF stage), but the waveform is not clean (i. e., it is full of "grass" or tube noise). It would be advisable to go back to the input of the 2nd IF stage. Connect the oscilloscope lead to any convenient point in the audio circuit, such as the high side of the volume control. Turn the SWEEP WIDTH control down somewhat, so that the line crossing the base line is as long as possible. Adjust the detector primary trimmer or slug for the straightest possible line. Increase the sweep width to obtain the entire S-curve, and switch the FMO-1 to 400 ~ MOD. Advance the modulation LEVEL control fully. Increase the setting of the marker LEVEL control somewhat and note the behavior of the pattern. Ignoring the loops of the S-curve, adjust the detector secondary for minimum agitation of the base line. This adjustment is usually quite sharp. It may be possible to observe more than one null, but at only one place will the "wiggles" on the base line cross over to the other side. The desired null is exactly at the crossover point. Turn the MODULATION switch to 100 kc MOD and 100 kc "pips" should be apparent at the tips of the S-curve loops. Once again, distortion is present, so use good judgement. If the S-curve without markers appears unbalanced, it is probably due to over driving the IF stages with the input sweep signal; reduce the signal level with the OUTPUT control, and rebalance the detector secondary.

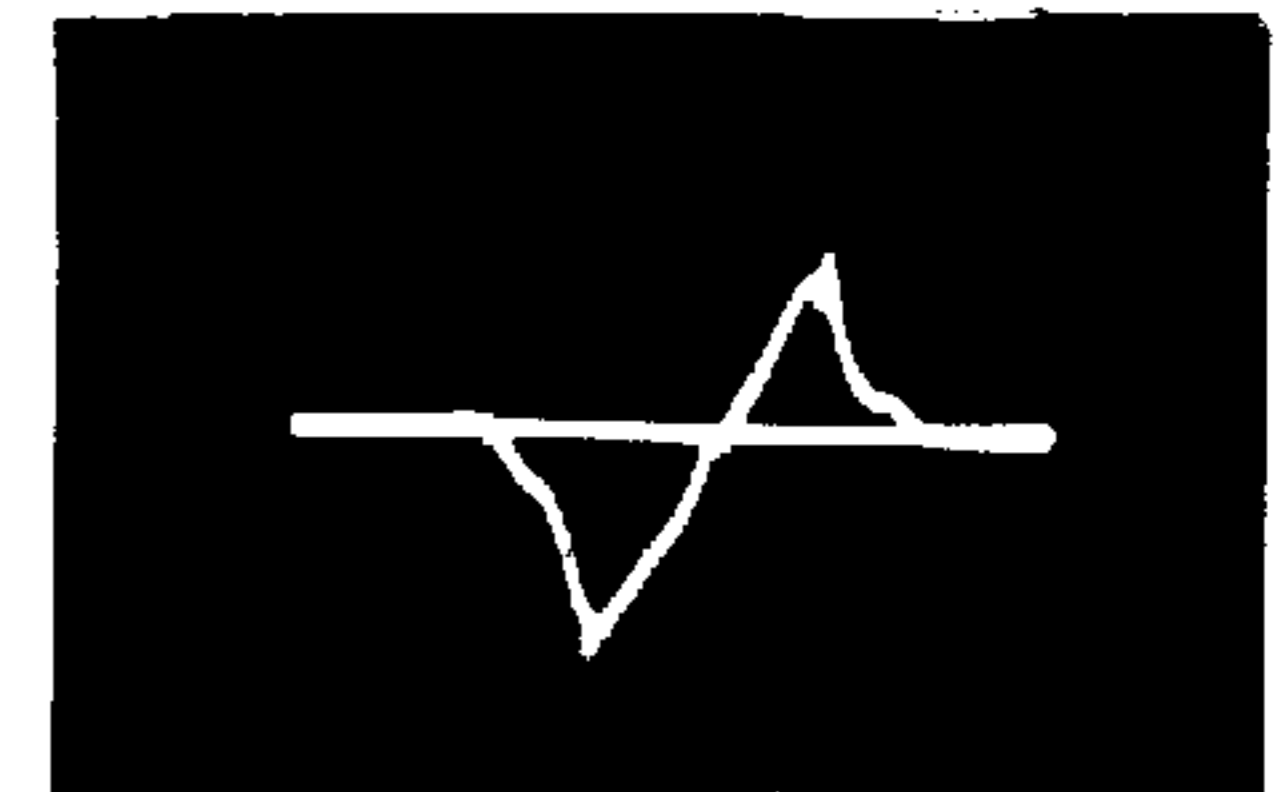
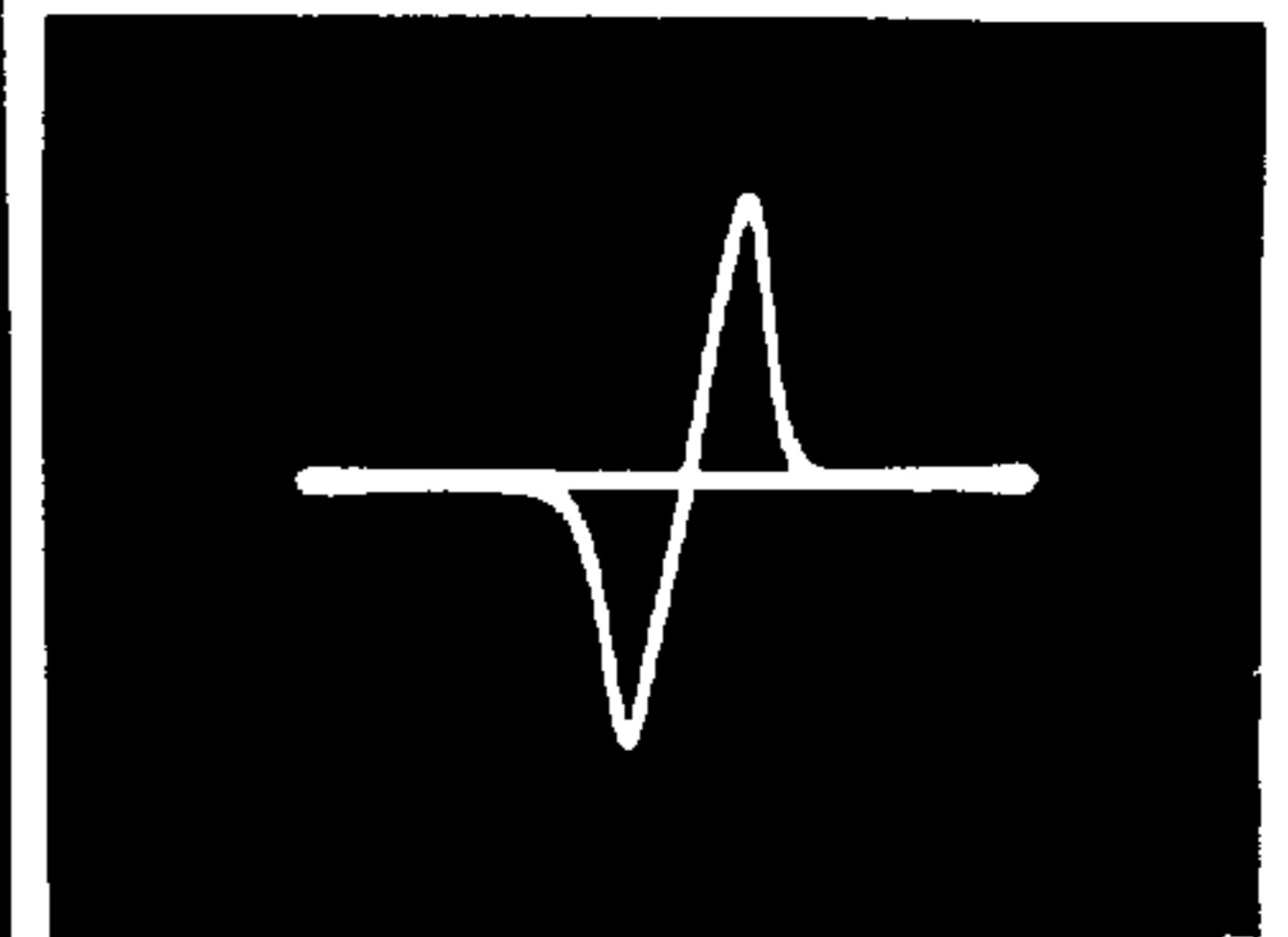
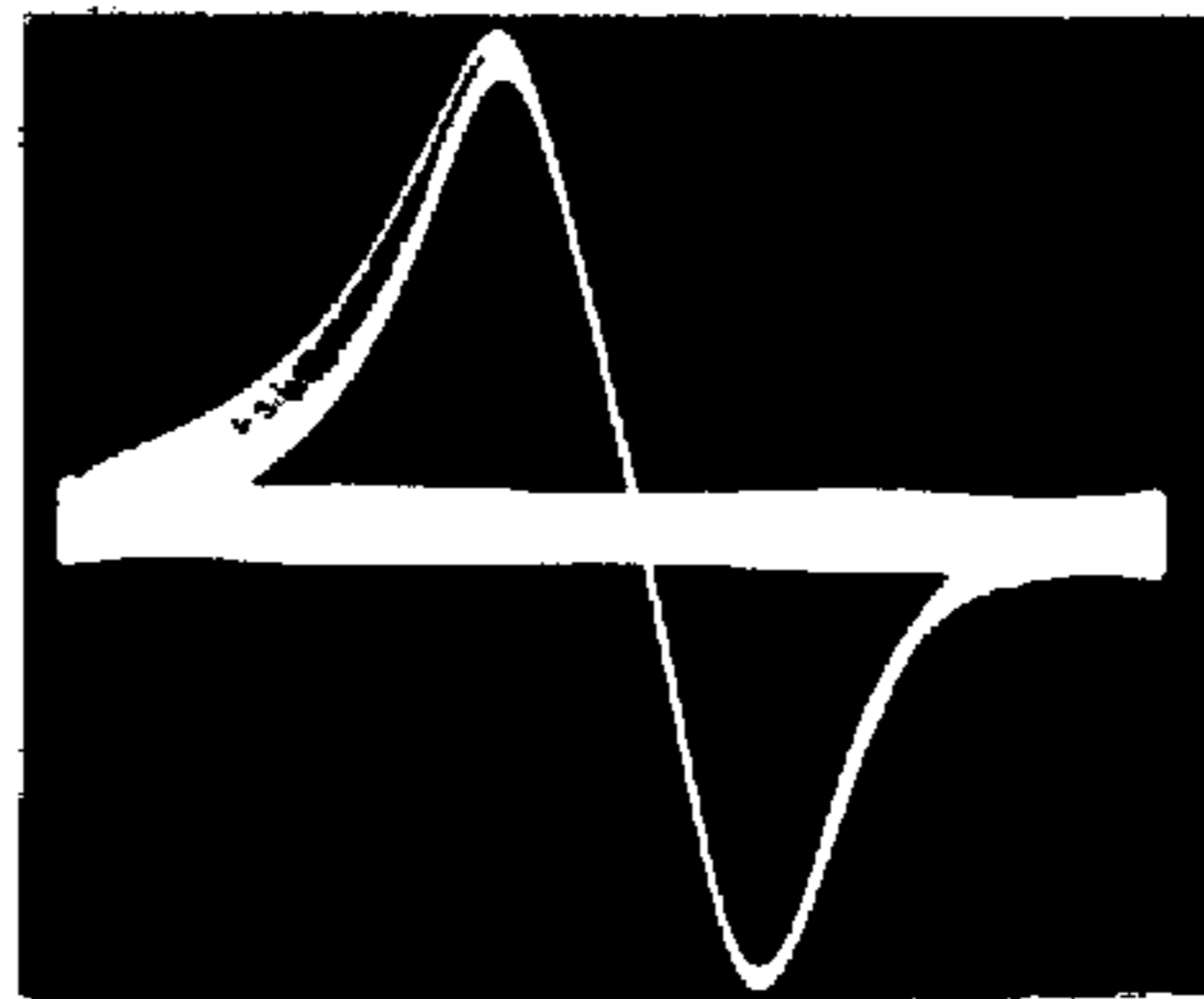

#### Front-end Alignment:

Reconnect the oscilloscope to the AM detection point used for IF alignment. Connect the FMO-1 test cable to the antenna terminals of the tuner or receiver. Insert a 120  $\Omega$  or 150  $\Omega$  resistor in series with each side of the test cable, to act as a dummy antenna.

Set the FMO-1 to deliver a 107 mc modulated signal (Main Frequency Selector on 107 mc, MARKER oscillator switch OFF, and MODULATION switch on 400 ~ MOD). Advance the modulation LEVEL control fully.

Turn the dial pointer from end to end, to determine if equal overlap is present on both ends of the dial. Set the dial at the 107 mc point and adjust the local oscillator trimmer for a sine-wave on the oscilloscope. The amplitude of the noise will increase on both sides of 107 mc, but at the one point the sine-wave is clearly visible. Adjust the antenna trimmer for maximum amplitude of the sine-wave. Switch the FMO-1 to the 90 mc position and adjust the oscillator slug or padder until the signal is obtained at the 90 mc spot on the tuner or receiver dial. Some less expensive receivers do not use a slug or padder, but rely on adjusting the spacing of the turns in the oscillator coil. If this is the case, move the turns nearer or farther apart until the signal appears at

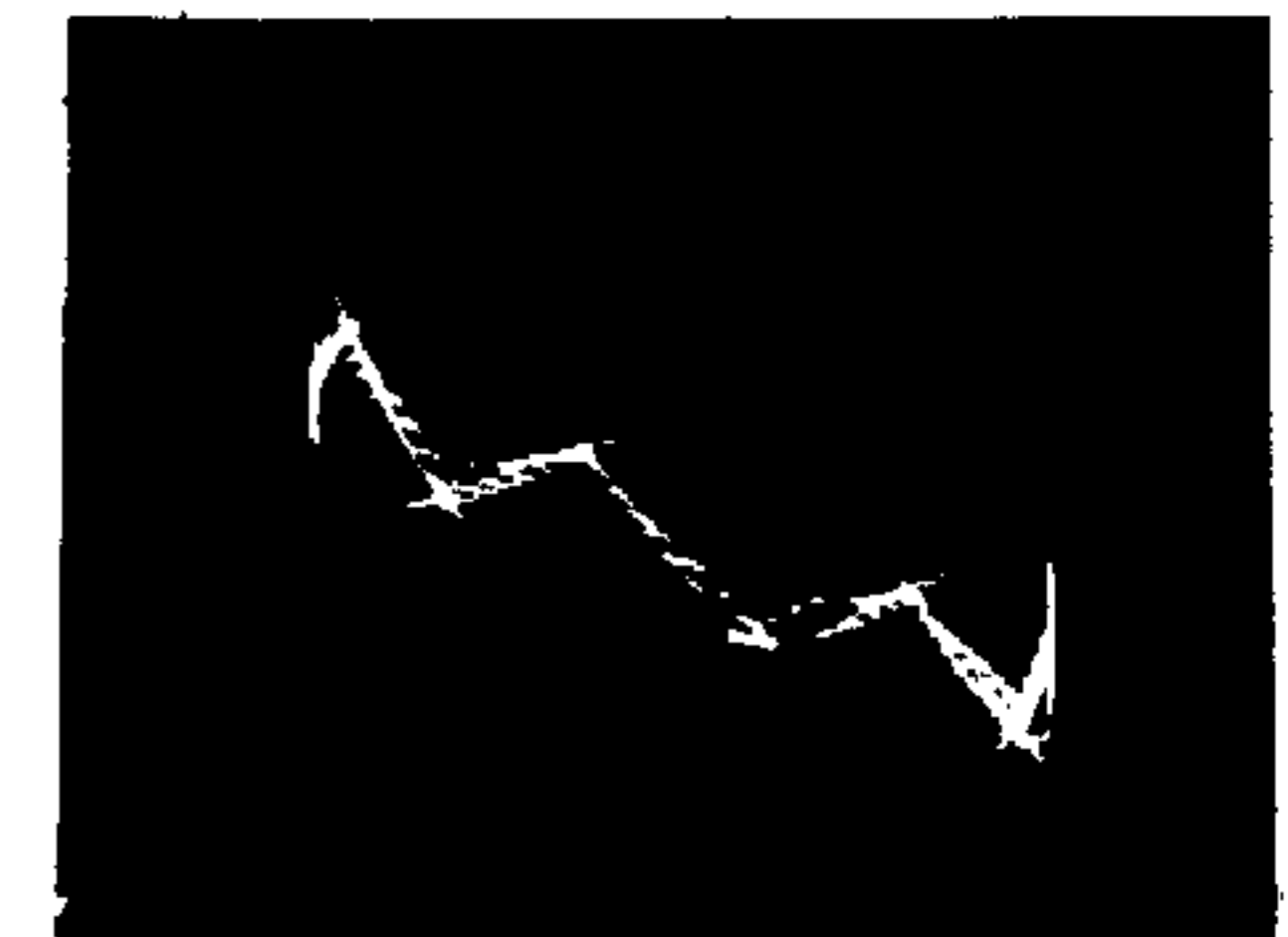

the 90 mc point on the dial. Adjust the padders or coil inductances of the antenna and RF circuits for maximum amplitude on the oscilloscope.

Go back and readjust the high end of the band, and check again at the low end. Continue in this manner until no further improvement can be made. The 100 mc signal should now be very close to the 100 mc spot on the dial. If not, the tuning capacitor plates will have to be "knifed", to restore tracking. This is a rather involved process and is best left to the experts; a detailed explanation of the procedure is beyond the scope of this manual.

It is possible to use an audible indication from the speaker for front-end oscilloscope alignment, but its successful use depends upon practice. Since considerable AM is present on the modulated carriers, slope detection takes place when the signal is slightly detuned. This results in more audible output on either side of proper tuning than at dead center. If this method is used, be certain to listen for maximum quieting of the noise and the purest tone, rather than maximum volume from the speaker. RF and antenna adjustments require an indicating device such as a meter or oscilloscope.

This completes the alignment procedure.

### METHOD II (Peak alignment of IF's)

#### Material required:

**CAUTION:** This method is not suitable for extremely broad-band IF systems and may lead to oscillation in more sensitive receivers.

- One vacuum tube voltmeter or
- A DC microammeter in series with 100,000 ohms
- One .05  $\mu$ f 400 V capacitor

#### IF Alignment:

Where the conventional limiter-discriminator circuitry is used, connect the VTVM across the first limiter grid resistor. The bias voltage developed when signal is applied will serve as a means of obtaining an output indication. Thus, the limiter serves as an AM detector and alignment is carried on as for an AM receiver.

Where a ratio detector is employed, connect the meter across the detector load resistor, and detune the secondary of the ratio detector transformer about one full turn of the adjustment trimmer or slug. When using a limiter-discriminator, connect as shown.

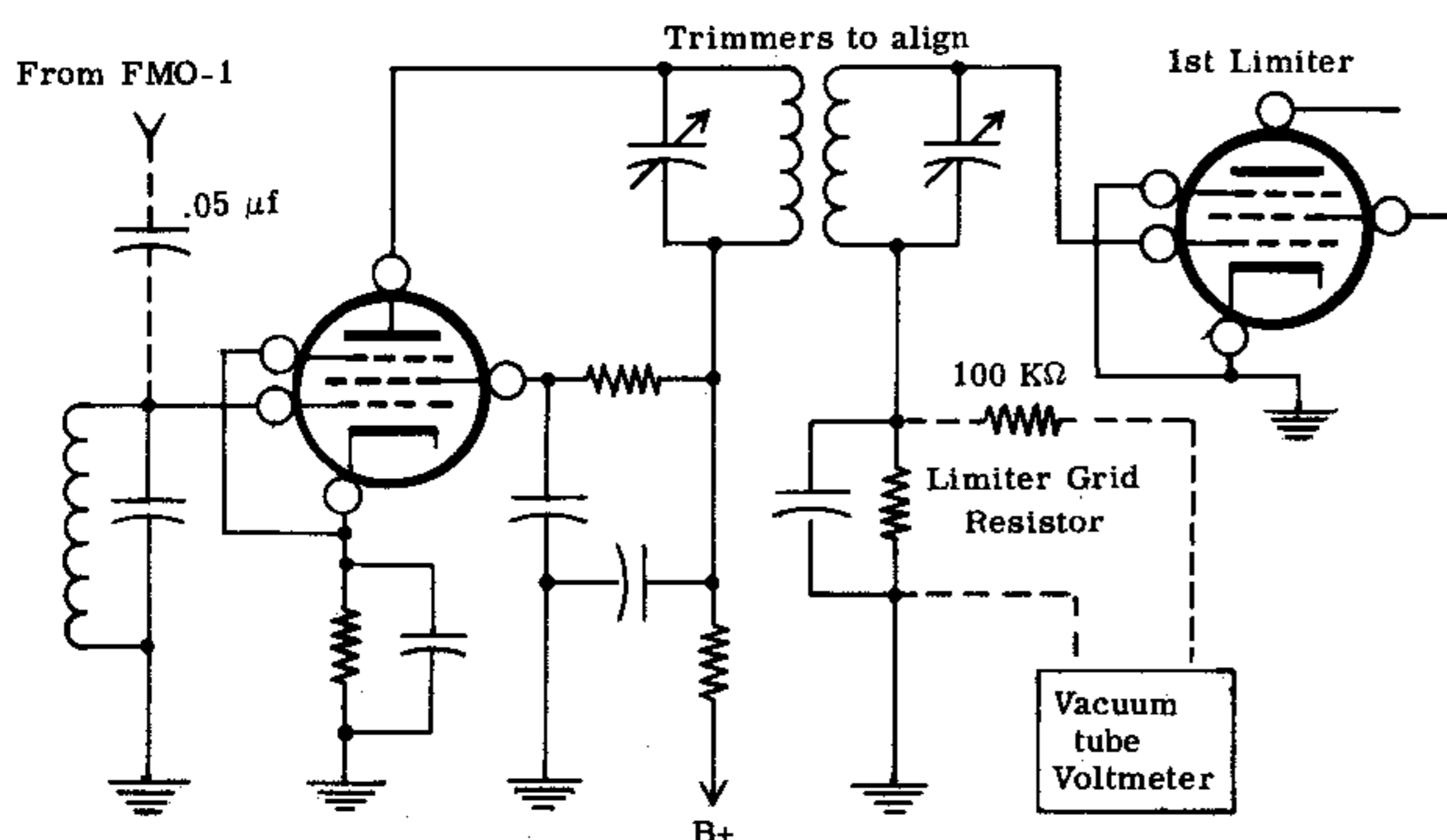

LIMITER DISCRIMINATOR

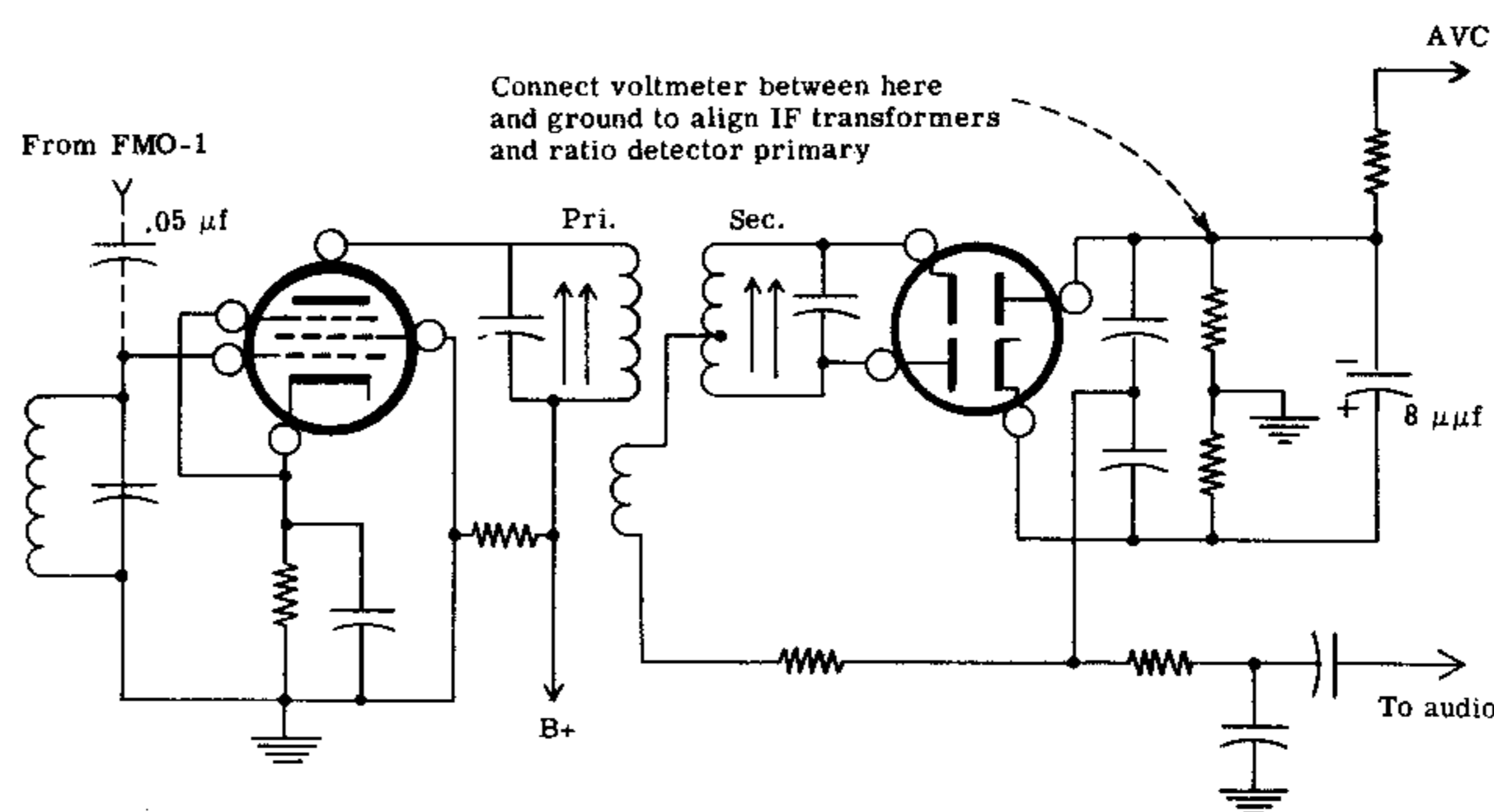

RATIO DETECTOR

Connect the FMO-1, through a .05  $\mu$ f capacitor, to the grid of the last IF tube. Set the control to obtain a 10.7 mc marker signal and tune the IF transformer primary and secondary for maximum deflection on the meter. Move the lead from the FMO-1 to the next IF amplifier tube grid (proceeding toward the antenna.), and once again tune for maximum. Continue in this manner until all of the IF's have been peak aligned.

Begin the alignment procedure with the detector transformer. Keep the FMO-1 output at the lowest usable level. Adjust the primary slug for a maximum reading on the meter. This being done, proceed to the next slug. Align each slug for a maximum reading on the meter, and so on.

Since the response characteristic of an FM IF strip is relatively flat-topped, retuning is necessary to go from this peaked characteristic to a flat-topped characteristic. To do this, put a flag with a piece of tape on your alignment tool, as shown in the accompanying Detail. The purpose of this flag is to indicate the approximate center of the flat-topped response of each winding that you adjust. As an example, suppose the peak meter reading for a particular adjustment is 5 volts. As you continuously turn the adjustment slug in a clockwise manner, you will note that the meter will gradually read more and go up through, for example, 4.7 volts, read 5, seem to stay rather flat around 5 for a few moments and then proceed back down through 4.7 volts again and decrease from that point still further. The portion where it stays relatively flat around the 5 volt area would be the point where it is properly peaked. What is desired is to adjust each coil in this manner and adjust the tool so that the slug will be positioned exactly in the center of this rather flat portion of the response. In this particular example, note the direction in which the flag was pointed when the meter was reading 4.7 volts the first time. Continue on through 5 volts until the meter comes back down to 4.7 volts again, and note the position of the flag. The correct setting for this particular slug would be the halfway point between these two flag positions.

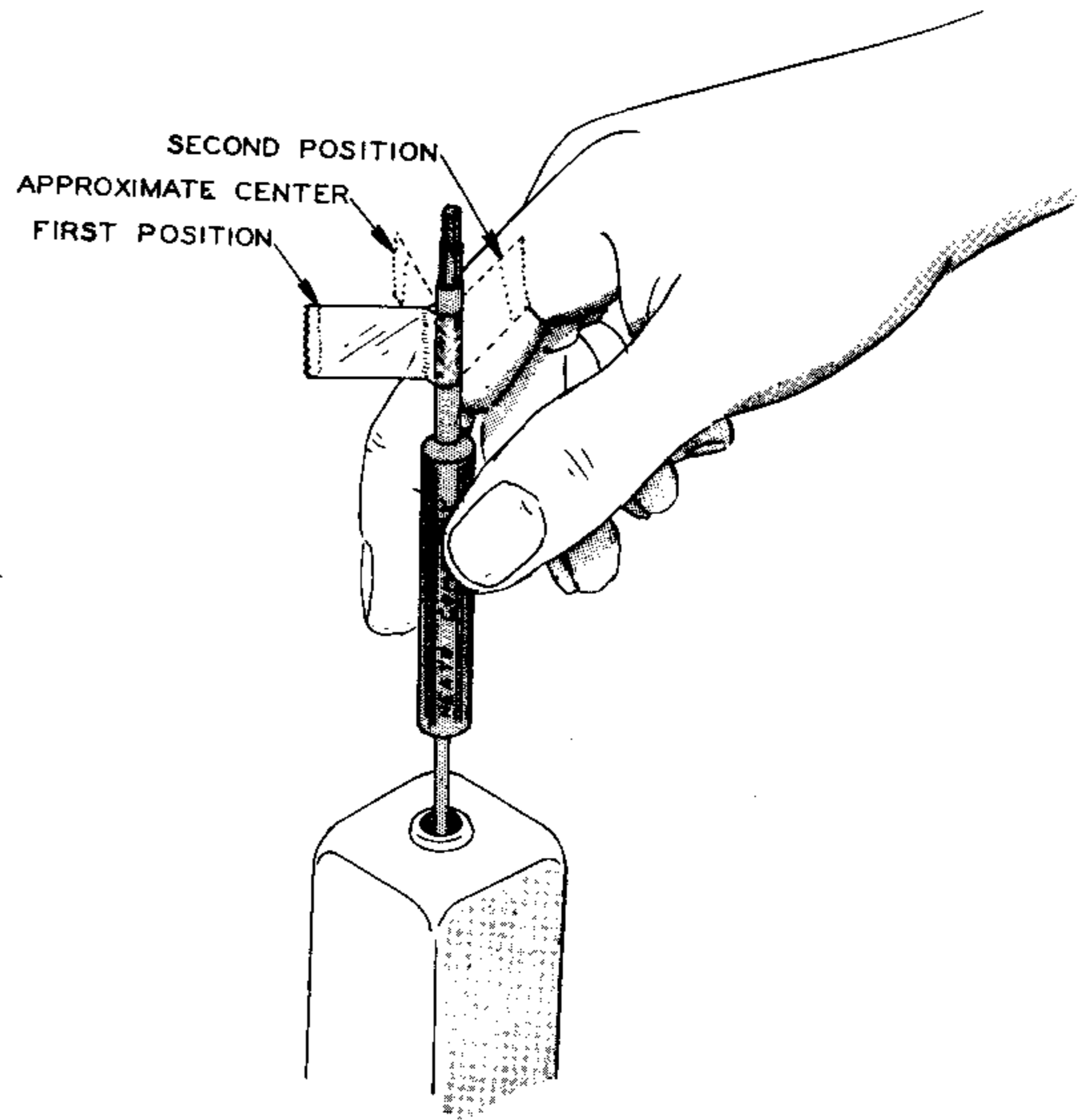

In the same manner, adjust each of the slugs for the center portion of this relatively flat response. Each one of these slugs should be quite close to the maximum response that was obtained previously.

This completes the IF alignment procedure.

#### Detector Alignment:

##### Discriminator:

Connect the VTVM across the discriminator load resistors, from the high side to ground.

Connect the FMO-1, through the .05  $\mu$ fd capacitor, to the grid of the last IF amplifier stage and set it to deliver a 10.7 mc unmodulated signal.

If the VTVM reads exactly zero, detune the discriminator transformer secondary slightly, to obtain a reading. Now tune the primary for maximum meter deflection. The secondary is then adjusted so the output voltage is exactly zero.

##### Ratio detector:

Connect the VTVM to the audio output of the detector before the coupling capacitor. The ratio detector secondary is now adjusted for zero voltage.

If the end of the detector load resistor is grounded instead of the center tap, it is necessary to connect two equal resistors in series across the load. Connect the ground lead of the voltmeter to the junction of these two resistors when adjusting the ratio detector transformer secondary. The sum of the two added resistors should be about ten times the total of the load resistors used in the circuit.

Occasionally, other forms of detectors are encountered. Alignment of these not-so-common circuits requires manufacturer's data. In most cases, it will be a simple matter for the technician to obtain the necessary test signals from the FMO-1, since almost any conceivable combination of FM test frequencies are available. A description of the possible combinations, and the control settings to obtain them, will be found in the SUMMARY.

#### Front-end alignment:

Connect the VTVM to one of the AM detection points described under "IF alignment". The procedure for the actual alignment will be identical to that used with an oscilloscope, except the signal will be unmodulated and maximum meter deflection is used as an indication of proper tuning.

### SUMMARY

The proper sequence of alignment is as follows:

First - the IF system, beginning with the last stage and progressing toward the front-end.

Second - the detector.

Third - the front end.

Which method of alignment is used is up to the technician. As a rule, the higher quality tuners and receivers should not be aligned other than visually, using an oscilloscope and sweep signals. The meter method should be used only where no oscilloscope is available, or on less expensive, older model receivers where performance need not be up to the present-day standards of high fidelity reproduction.

Whenever possible, it is best to follow the individual manufacturer's instructions for alignment. This presents no great problem for the FMO-1, since it contains, in specialized form, most of the features and functions of more generalized equipment. The manufacturer may state, for example, to align the high end of the band at 106 mc on the dial. The FMO-1 is capable of 107 mc, which is close enough to get essentially identical results. Alignment data may call for shifting the marker frequency to a value other than 10.7 mc to check IF band-pass. A very close estimate may be made using the 100 kc submarkers, still retaining the 10.7 mc center-frequency as a reference point.

98 mc may be the mid-band check-point called for in the service data. The 100 mc position of the FMO-1 is slightly higher, and the 9th harmonic of the 10.7 mc crystal oscillator falls at 96.3 mc, just slightly lower. This gives two check-points, rather than just one.

The examples which follow illustrate how the instrument may be adapted to fit a wide range of needs, covering almost any alignment job.

### Output Signals:

The full range of frequencies available are:

<u>Frequency</u>	<u>How obtained</u>	<u>Use</u>
400-cycle audio	Direct switching	Testing audio circuits, modulation signal
100 kc	Direct switching	Calibrating instruments, modulation signal, marker
10.0 mc	Direct switching	Calibrating instruments
10.7 mc	Direct switching	Calibrating instruments, center IF frequency, marker
10.7 sweep	Direct switching	IF sweep alignment
90 mc	Direct switching	Front-end alignment
96.3 mc	10.7 mc osc. harmonic	Front-end alignment
100 mc	Direct switching	Front-end alignment
107 mc	Direct switching	Front-end alignment

The following may be modulated by 400 cycles or 100 kc:

- 10.0 mc (AM)
- 10.7 mc (AM)
- 90 mc (AM plus incidental FM)
- 100 mc (AM plus incidental FM)
- 107 mc (AM plus incidental FM)

Either crystal oscillator frequency may be used simultaneously with any other available frequency (the 400-cycle and 100 kc are modulating signals, rather than being mixed).

The output from the crystal (marker) oscillator may be mixed with the output from the high frequency oscillator at the same time one of the two is being modulated with a 400-cycle or 100 kc signal.

The small red knobs control the output amplitude of the modulation and marker oscillators independently. The main OUTPUT control adjusts the level of all signals appearing at the output connector, simultaneously.

Where low FMO-1 output is desired, turn the RF-AF switch to the RF position, and terminate the test cable with the 56 ohm resistor. Where higher output is required, switch to the AF position. This removes the 56 ohm resistor at the instrument end of the cable, approximately doubling the output. When the 400-cycle audio is used alone, disconnect the 56 ohm resistor at the cliplead end of the test cable, as well as switching to the AF position. The output, then, is high impedance.

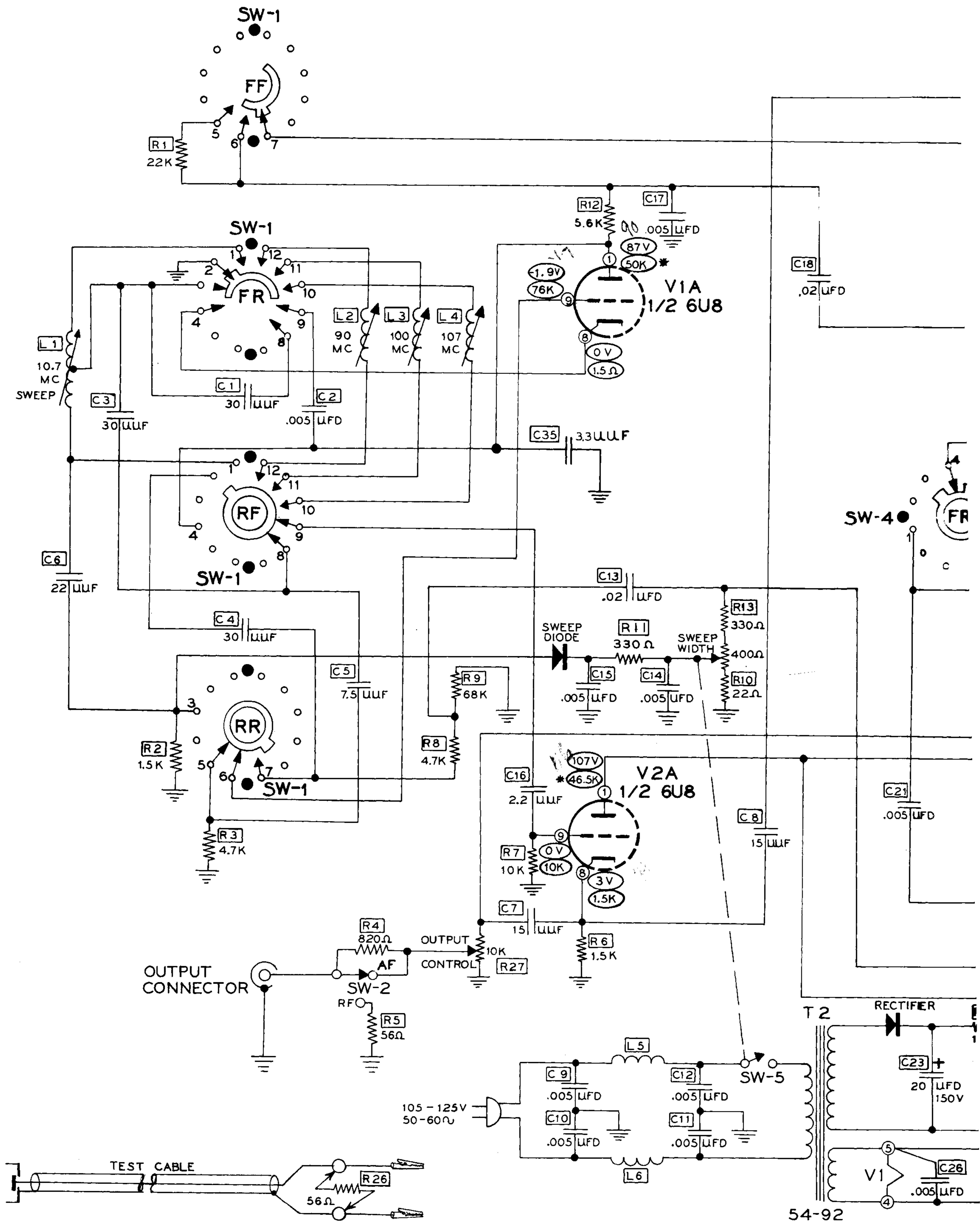

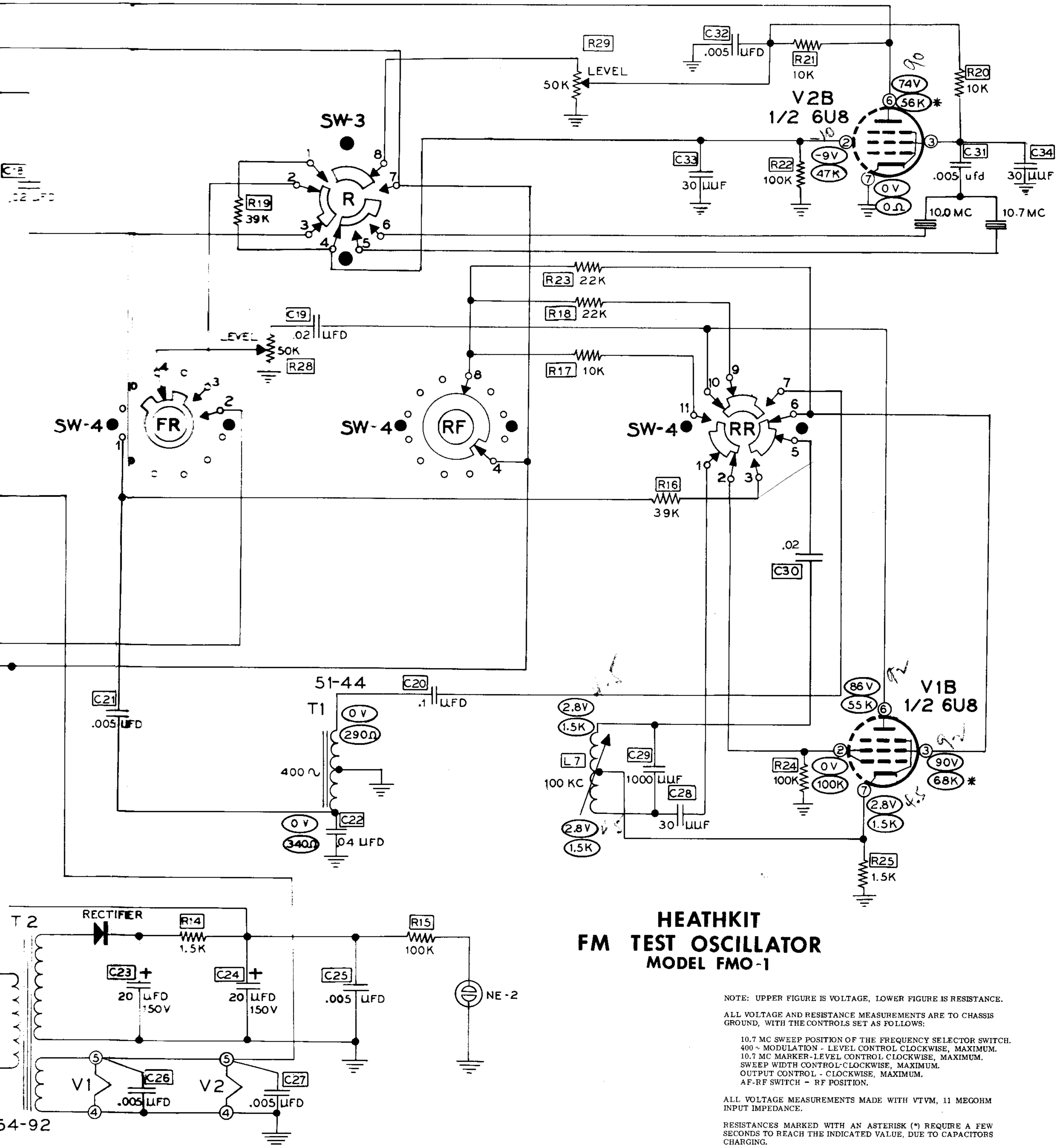

## HEATHKIT FM TEST OSCILLATOR MODEL FMO-1

NOTE: UPPER FIGURE IS VOLTAGE, LOWER FIGURE IS RESISTANCE.

ALL VOLTAGE AND RESISTANCE MEASUREMENTS ARE TO CHASSIS GROUND, WITH THE CONTROLS SET AS FOLLOWS:

- 10.7 MC SWEEP POSITION OF THE FREQUENCY SELECTOR SWITCH.
- 400 ~ MODULATION - LEVEL CONTROL CLOCKWISE, MAXIMUM.
- 10.7 MC MARKER-LEVEL CONTROL CLOCKWISE, MAXIMUM.
- SWEEP WIDTH CONTROL - CLOCKWISE, MAXIMUM.
- OUTPUT CONTROL - CLOCKWISE, MAXIMUM.
- AF-RF SWITCH - RF POSITION.

ALL VOLTAGE MEASUREMENTS MADE WITH VTVM, 11 MEGOHM INPUT IMPEDANCE.

RESISTANCES MARKED WITH AN ASTERISK (\*) REQUIRE A FEW SECONDS TO REACH THE INDICATED VALUE, DUE TO CAPACITORS CHARGING.

# Heathkit FM TEST OSCILLATOR

50 MC

10.7 MC  
SWEEP

100 MC

OFF

10.7 MC



MODULATION

MARKER OSC.

100 MC  
MOD.

100 MC  
OUT

100 MC

OFF

10.7 MC

OFF



LEVEL

LEVEL

MODEL FMD-1



SWEEP WIDTH

OUTPUT



A.F. OFF

RF

AF

MAX



HEATHkit

SUBSIDIARY OF MAYSTONE, INC.