

HEATHKIT[®] MANUAL

for the

**STATION
MONITOR**
Model SB-614

595-1686-04

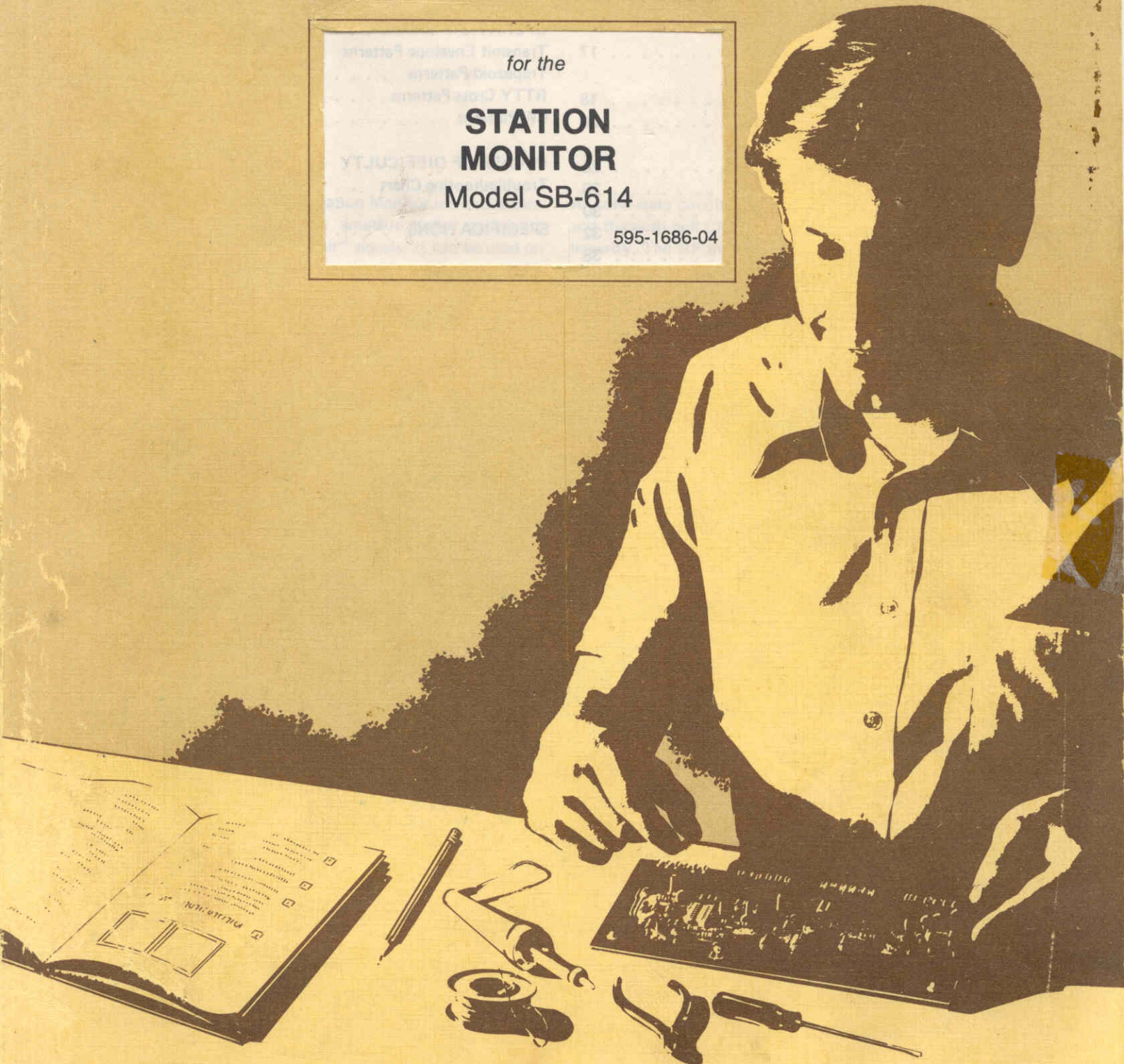

HEATH COMPANY • BENTON HARBOR, MICHIGAN

HEATH COMPANY PHONE DIRECTORY

The following telephone numbers are direct lines to the departments listed:

Kit orders and delivery information (616) 982-3411
Credit (616) 982-3561
Replacement Parts (616) 982-3571

Technical Assistance Phone Numbers

8:00 A.M. to 12 P.M. and 1:00 P.M. to 4:30 P.M., EST, Weekdays Only
R/C, Audio, and Electronic Organs (616) 982-3310
Amateur Radio (616) 982-3296
Test Equipment, Weather Instruments and
Home Clocks (616) 982-3315
Television (616) 982-3307
Aircraft, Marine, Security, Scanners, Automotive,
Appliances and General Products (616) 982-3496
Computers — Hardware (616) 982-3309
Computers — Software:
Operating Systems, Languages, Utilities (616) 982-3860
Application Programs (616) 982-3884
Heath Craft Wood Works (616) 982-3423



YOUR HEATHKIT 90-DAY LIMITED WARRANTY

Consumer Protection Plan for Heathkit Consumer Products

Welcome to the Heath family. We believe you will enjoy assembling your kit and will be pleased with its performance. Please read this Consumer Protection Plan carefully. It is a "LIMITED WARRANTY" as defined in the U.S. Consumer Product Warranty and Federal Trade Commission Improvement Act. This warranty gives you specific legal rights, and you may also have other rights which vary from state to state.

Heath's Responsibility

PARTS — Replacements for factory defective parts will be supplied free for 90 days from date of purchase. Replacement parts are warranted for the remaining portion of the original warranty period. You can obtain warranty parts direct from Heath Company by writing or telephoning us at (616) 982-3571. And we will pay shipping charges to get those parts to you . . . anywhere in the world.

SERVICE LABOR — For a period of 90 days from the date of purchase, any malfunction caused by defective parts or error in design will be corrected at no charge to you. You must deliver the unit at your expense to the Heath factory, any Heathkit Electronic Center (units of Veritechnology Electronics Corporation), or any of our authorized overseas distributors.

TECHNICAL CONSULTATION — You will receive free consultation on any problem you might encounter in the assembly or use of your Heathkit product. Just drop us a line or give us a call. Sorry, we cannot accept collect calls.

NOT COVERED — The correction of assembly errors, adjustments, calibration, and damage due to misuse, abuse, or negligence are not covered by the warranty. Use of corrosive solder and/or the unauthorized modification of the product or of any furnished component, will void this warranty in its entirety. This warranty does not include reimbursement for inconvenience, loss of use, customer assembly, set-up time, or unauthorized service.

This warranty covers only Heath products and is not extended to other equipment or components that a customer uses in conjunction with our products.

SUCH REPAIR AND REPLACEMENT SHALL BE THE SOLE REMEDY OF THE CUSTOMER AND THERE SHALL BE NO LIABILITY ON THE PART OF HEATH FOR ANY SPECIAL, INDIRECT, INCIDENTAL OR CONSEQUENTIAL DAMAGES, INCLUDING BUT NOT LIMITED TO ANY LOSS OF BUSINESS OR PROFITS, WHETHER OR NOT FORSEEABLE.

Some states do not allow the exclusion or limitation of incidental or consequential damages, so the above limitation or exclusion may not apply to you.

Owner's Responsibility

EFFECTIVE WARRANTY DATE — Warranty begins on the date of first consumer purchase. You must supply a copy of your proof of purchase when you request warranty service or parts.

ASSEMBLY — Before seeking warranty service, you should complete the assembly by carefully following the manual instructions. Heathkit service agencies cannot complete assembly and adjustments that are customer's responsibility.

ACCESSORY EQUIPMENT — Performance malfunctions involving other non-Heath accessory equipment, (antennas, audio components, computer peripherals and software, etc.) are not covered by this warranty and are the owner's responsibility.

SHIPPING UNITS — Follow the packing instructions published in the assembly manuals. Damage due to inadequate packing cannot be repaired under warranty.

If you are not satisfied with our service (warranty or otherwise) or our products, write directly to our Director of Customer Service, Heath Company, Benton Harbor MI 49022. He will make certain your problems receive immediate, personal attention.

Heathkit® Manual

for the

STATION MONITOR Model SB-614

595-1686-04



HEATH COMPANY
BENTON HARBOR, MICHIGAN 49022

Copyright © 1974
Heath Company
All Rights Reserved
Printed in the United States of America

TABLE OF CONTENTS

INTRODUCTION	3	RF SAMPLING CHECKOUT	64
PARTS LIST	5	FINAL ASSEMBLY	67
STEP-BY-STEP ASSEMBLY			
Assembly Notes	17	OPERATION	71
Circuit Boards		Transmit Envelope Patterns	77
Demodulator Circuit Board	18	Trapezoid Patterns	80
Main Circuit Board	20	RTTY Cross Patterns	82
Chassis and Cabinet		CW Patterns	83
Chassis Assembly Notes	28	IN CASE OF DIFFICULTY	85
Chassis	28	Troubleshooting Chart	86
Rear Panel	30	SPECIFICATIONS	91
Rear Panel-Chassis Wiring	32	CIRCUIT DESCRIPTION	93
Side Panel Mounting	38	CHASSIS PHOTOGRAPHS	96
Main Circuit Board Wiring	39	CIRCUIT BOARD X-RAY VIEWS	99
Left Side Panel Assembly	40	CIRCUIT BOARD VOLTAGE CHARTS	101
Front Panel Parts Mounting	43	TRANSISTOR IDENTIFICATION CHART	103
Front Panel Prewiring	44	SCHEMATIC (fold-out from page)	103
Front Panel Assembly	45	WARRANTY	Inside front cover
Front Panel Wiring	47	CUSTOMER SERVICE	Inside rear cover
CRT Installation	51		
CRT Wiring	52		
RF Shield Assembly	54		
Knob Installation	57		
INITIAL TESTS	59		
ADJUSTMENTS			
Trace	61		

INTRODUCTION

The Heathkit Model SB-614 Station Monitor is a convenient instrument for use with an amateur radio station to continuously observe "on-the-air" signals. It can be used on all bands and frequencies from the 80-meter through the 6-meter amateur bands without additional tuning or modification. Ten watts of RF energy will provide a useful display, while a full 1000 watts of RF input can be adjusted for any display height with a front-panel-controlled attenuator.

The primary function of the Station Monitor is to display RF envelope (SSB), RF trapezoid (TRAP), or radioteletype (CROSS) transmitted signal patterns. It can also be used to monitor audio signals from other stations when used in conjunction with a receiver. The Monitor aids in proper alignment and tuning of a transmitter in AM, CW or SSB; its display will indicate nonlinearity, insufficient or excessive drive, poor carrier or sideband suppression, regeneration, parasitics, and CW key clicks. Approximately forty CRT display illustrations are shown and outlined in this Manual to illustrate transmitter problems.

For limited test applications, the Station Monitor can also be used as a normal oscilloscope. In this function, audio signals from 10 Hz to 50 kHz can be displayed with good sync capability and high input sensitivity. Also featured is a 10:1 vertical input switch attenuator which maintains a constant input impedance regardless of the switch position.

All-solid-state circuits are used, except for the display tube, and the push-pull CRT drivers improve the display focus and linearity. The RF input to the CRT deflection plates is also push-pull, and a one-piece, full CRT shield minimizes stray magnetic field effects. Automatic clamp circuitry is included for trapezoid displays. Display mode – SSB, Trap, or Cross – is shown by status lamps on the front panel.

The color and styling of the Station Monitor was designed to match that of the Heathkit line of amateur radio equipment. However, this unit can be used with similar amateur or commercial transmitters whose output levels and frequencies are within its specified limits. The Station Monitor can be wired to utilize either 110 to 130 VAC or 220 to 240 VAC, 50 or 60 Hz. With two circuit boards, a preassembled cable harness, and a wide-open layout, this Station Monitor is both an easy kit to assemble and a useful addition to your "ham shack."

Refer to the "Kit Builders Guide" for information about unpacking, parts identification, tools, wiring, soldering, and step-by-step assembly procedures.

PARTS LIST

This "Parts List" contains all of the parts used in the assembly of your kit. Some parts may be packaged in envelopes with the part number of the contents printed on the outside. Except for the initial parts check, keep these parts in their envelopes until they are called for in the assembly steps. When more than one number is on a package, disregard all but the part number listed in the "Parts List."

Check each part against the following list. Make a check (✓) in the space provided as you identify each part.

To order a replacement part, always include the PART NUMBER. Use the Parts Order Form furnished with the kit. If one is not available, see "Replacement Parts" inside the rear cover of this Manual. Your Warranty is located inside

the front cover. For pricing information, refer to the separate "Heath Parts Price List."

Each circuit part in this kit has its own component number (R2, C4, etc.). Use these numbers when you want to positively identify the same part in the various sections of the Manual. These numbers, which are especially useful if a part has to be replaced, appear:

- In the parts list,
- At the beginning of each step where a component is installed,
- In some illustrations,
- In the Schematic,
- In the sections at the rear of the Manual.

QTY.	DESCRIPTION	PART No.	CIRCUIT Component No.
------	-------------	----------	-----------------------

RESISTORS

NOTE: A fourth color band of silver indicates 10% tolerance;
a fourth band of gold indicates 5% tolerance.

1/2-Watt

() 1	68 Ω (blue-gray-black)	1-2	R158
(✓) 5	100 Ω (brown-black-brown)	1-3	R122, R131, R132, R142, R143
() 1	180 Ω, 5% (brown-gray-brown)	1-112	R126
() 1	220 Ω (red-red-brown)	1-45	R205
(✓) 7	470 Ω (yellow-violet-brown)	1-16	R11, R117, R123, R133, R134, R145 R146

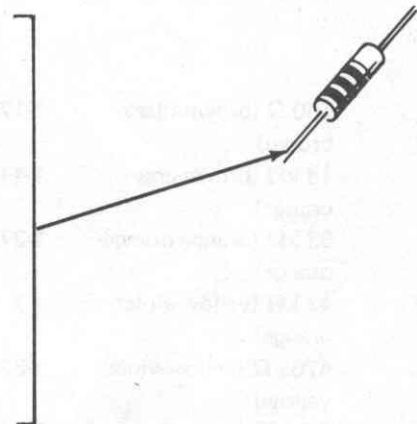

QTY.	DESCRIPTION	PART No.	CIRCUIT Component No.
() 17	1000 Ω (brown-black-red)	1-9	R103, R105, R112, R114, R115, R118, R124, R127, R129, R135, R136, R137, R138, R141, R144, R147, R157
(✓) 4	4700 Ω (yellow-violet-red)	1-16	R104, R106, R113, R121
() 1	10 k Ω (brown-black-orange)	1-20	R207
(✓) 2	15 k Ω (brown-green-orange)	1-21	R153, R202
() 1	18 k Ω (brown-gray-orange)	1-69	R206
(✓) 3	100 k Ω , 5% (brown-black-yellow)	1-104	R4, R116, R119
() 5	1 M Ω (brown-black-green)	1-35	R5, R18, R19, R107, R109
() 2	1.5 M Ω (brown-green-green)	1-36	R101, R125
() 1	3.3 M Ω (orange-orange-green)	1-38	R204
(✓) 1	5.6 M Ω (green-blue-green)	1-86	R102
(✓) 1	10 M Ω (brown-black-blue)	1-40	R111

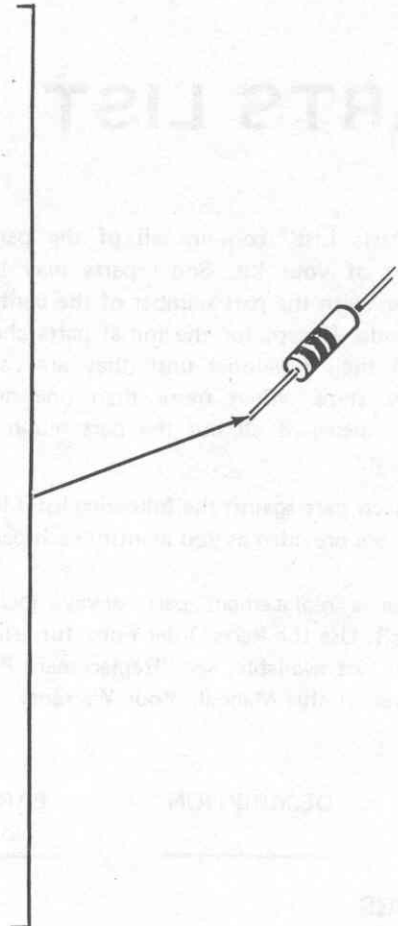
**1-Watt**

() 1	100 Ω (brown-black-brown)	1-17-1	R156
() 1	18 k Ω (brown-gray-orange)	1-44-1	R203
(✓) 1	33 k Ω (orange-orange-orange)	1-27-1	R13
(✓) 1	47 k Ω (yellow-violet-orange)	1-7-1	R2
() 2	470 k Ω (yellow-violet-yellow)	1-32-1	R16, R154
(✓) 1	2.2 M Ω (red-red-green)	1-36-1	R14

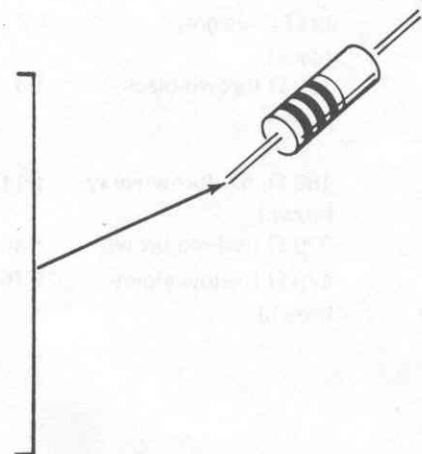

QTY.	DESCRIPTION	PART No.	CIRCUIT Component No.
Resistors (Cont'd.)			
Other Resistors			
(/) 1	1500 Ω , 2-watt (brown-green-red)	1-14-2	R201
() 1	47 k Ω , 2-watt (yellow-violet-orange)	1-10-2	R1
(/) 1	900 k Ω , precision	2-51	R3
(/) 1	2000 (2K), 10-watt, wire-wound	3-19-10	R155
(/) 4	10 k Ω , 7-watt, film	5-3-7	R148, R149, R151, R152
CAPACITORS			
Mica			
(/) 1	30 pF	20-100	C106
() 1	39 pF	20-159	C1
() 2	100 pF	20-102	C201, C202
() 1	300 pF	20-115	C203
(/) 1	.001 (1000 pF)	20-122	C204
Disc			
(/) 1	5 pF	21-78	C5
(/) 1	6.8 pF	21-61	C13
(/) 1	10 pF	21-3	C6
() 1	20 pF	21-5	C7
() 2	47 pF	21-32	C8, C14
() 1	100 pF	21-75	C9
(/) 1	150 pF	21-11	C11
() 2	270 pF	21-17	C19, C21
(/) 7	470 pF	21-56	C104, C105, C113, C115, C117, C118, C207
() 3	.001 μ F	21-163	C125, C205, C208
() 1	.0033 μ F (3300 pF)	21-141	C116
() 2	.01 μ F (small)	21-176	C101, C103
() 1	.01 μ F, 1.6 kV	21-42	C119
() 1	.2 μ F	21-99	C206
Electrolytic			
() 2	10 μ F vertical	25-115	C112, C114
(/) 3	50 μ F vertical	25-116	C107, C108, C126
(/) 3	250 μ F vertical	25-160	C127, C129, C131
() 2	70 μ F tubular	25-43	C124, C128

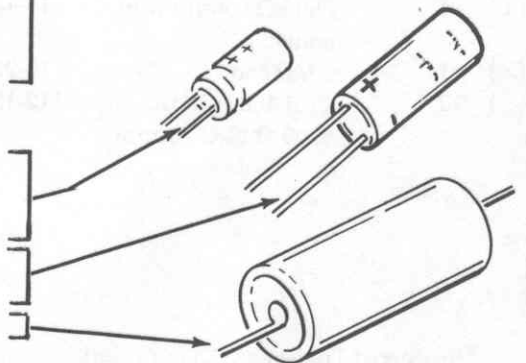
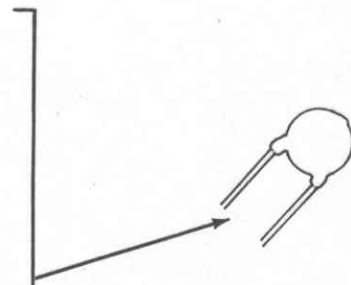
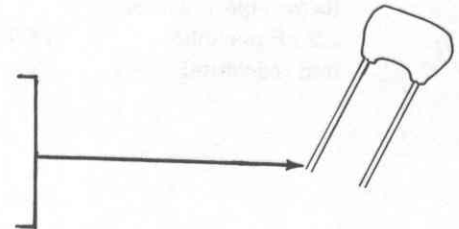
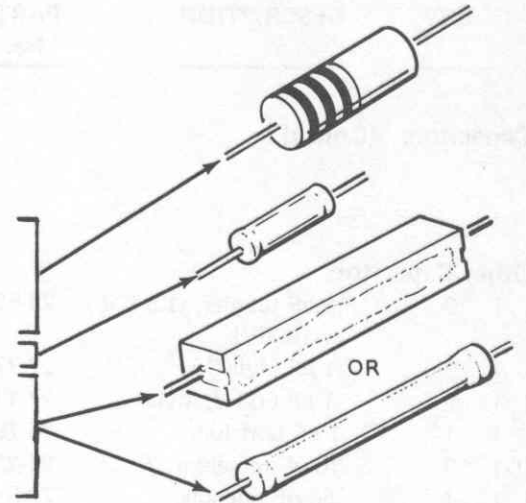

QTY.	DESCRIPTION	PART No.	CIRCUIT Component No.
Capacitors (Cont'd.)			
Other Capacitors			
(✓) 3	.1 μ F tubular, (1.6 KV or 1600V)	23-62	C121,C122, C123
(✓) 3	.1 μ F Mylar*	27-77	C17,C102,C109
(✓) 2	.1 μ F 600 V, Mylar	27-112	C12,C18
() 1	1 μ F tantalum	25-197	C16
(✓) 2	10 μ F tantalum	25-220	C15,C111
() 1	.56 pF phenolic (green-blue-gray)	28-3	C2
() 1	1 pF phenolic (brown-black-white)	28-2	C3
() 1	2.2 pF phenolic (red-red-white)	28-1	C4

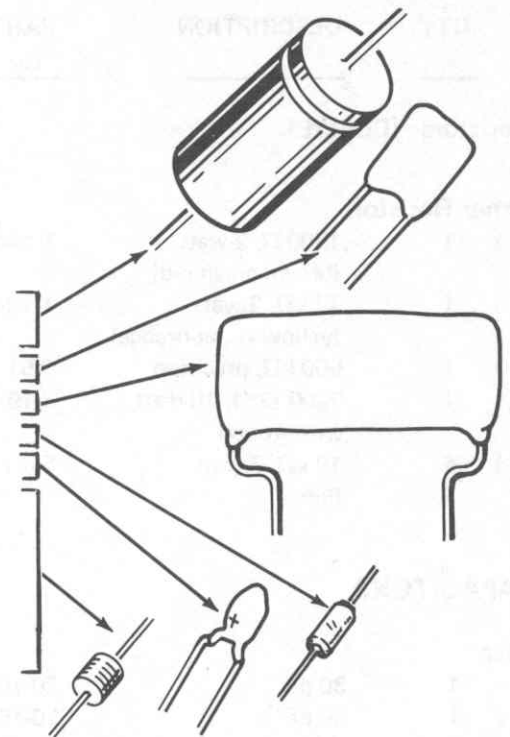

CONTROLS-SWITCHES

() 2	500 Ω control	10-381	R128, R139
(✓) 1	150 k Ω control	10-282	R21
() 1	250 k Ω control with switch	19-149	R17, SW5
(✓) 1	1 M Ω control	10-224	R15
(✓) 2	Dual 1000 Ω (1K), 5000 Ω (5K) control	12-139	R6, R7, R8, R9

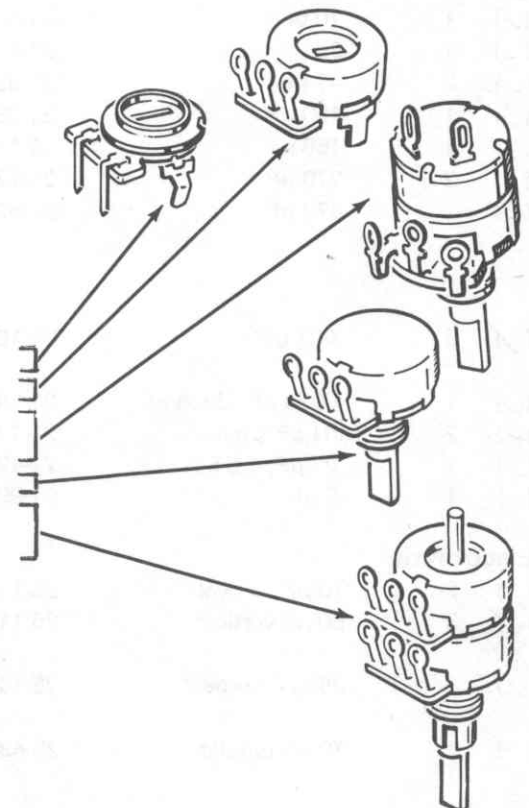

*Registered Trademark, DuPont Corp.

QTY.	DESCRIPTION	PART No.	CIRCUIT Component No.
------	-------------	----------	-----------------------

Controls - Switches (Cont'd.)

(✓) 1	Slide switch	60-4	SW3
() 1	12-lug rotary switch	63-1214	SW2
() 1	Rotary switch with 10 k Ω control	63-1215	R12, SW4
() 1	11-lug rotary switch (without detent)	63-1223	SW1

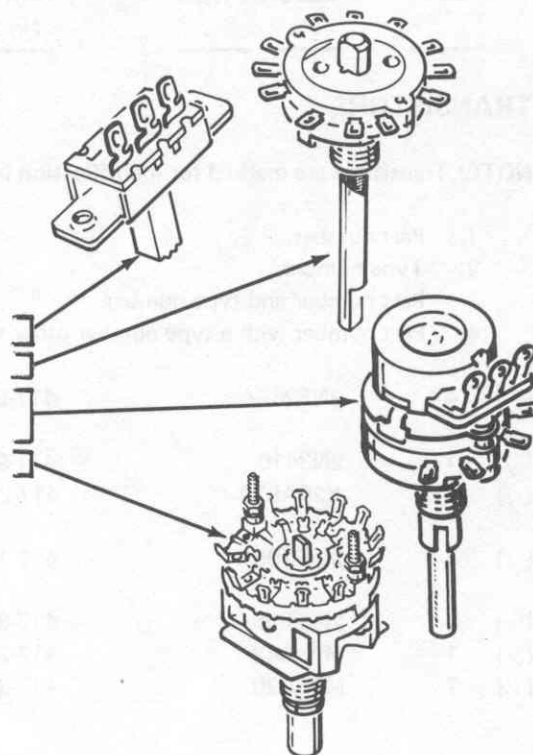

COIL-CHOKES-TRANSFORMER

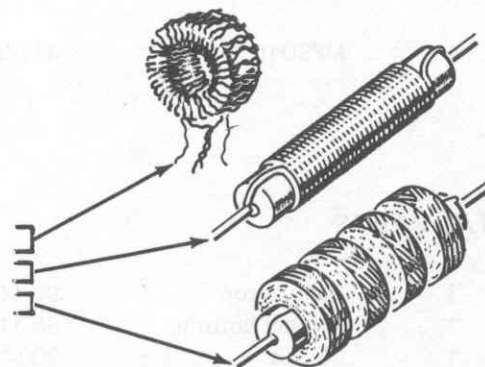
(✓) 1	Toroid coil	40-1736	L201
() 2	8.48 μ H choke	45-6	RFC2, RFC3
(✓) 2	500 μ H choke	45-30	RFC1, RFC4
() 1	Power transformer	54-182	T1

DIODES

(✓) 4	1N191 (brown-white-brown)	56-26	D201, D202, D203, D204
(✓) 1	BZT110A zener	56-48	ZD101
(✓) 1	VR-10A zener	56-67	ZD103
(✓) 1	ZVR-68 zener	56-68	ZD102
(✓) 4	1N2071	57-27	D109, D111, D112, D113
() 2	DO-7	57-52	D105, D106
() 3	1N4002	57-65	D1, D107, D108

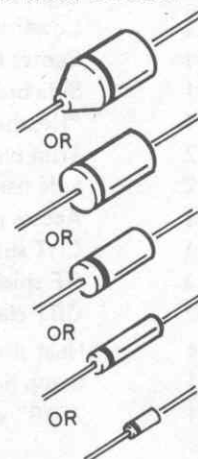
NOTE: HEATH PART NUMBERS ARE STAMPED ON MOST DIODES.



QTY.	DESCRIPTION	PART No.	CIRCUIT Component No.
------	-------------	----------	-----------------------

TRANSISTORS

NOTE: Transistors are marked for identification in one of the following four ways:

1. Part number.
2. Type number.
3. Part number and type number.
4. Part number with a type number other than the one listed.

() 4	2N5232A	417-91	Q103, Q105, Q117, Q119
() 1	2N3416	417-94	Q122
() 4	X29A829	417-201	Q109, Q111, Q112, Q113
() 4	MPF105	417-169	Q101, Q102, Q115, Q116
() 1	2N5458	417-291	Q201
() 1	MPSA42	417-294	Q114
() 7	MPSA20	417-801	D101, D102, D103, D104, ZD201, Q107, Q108
() 4	MPSU10	417-834	Q104, Q106, Q118, Q121

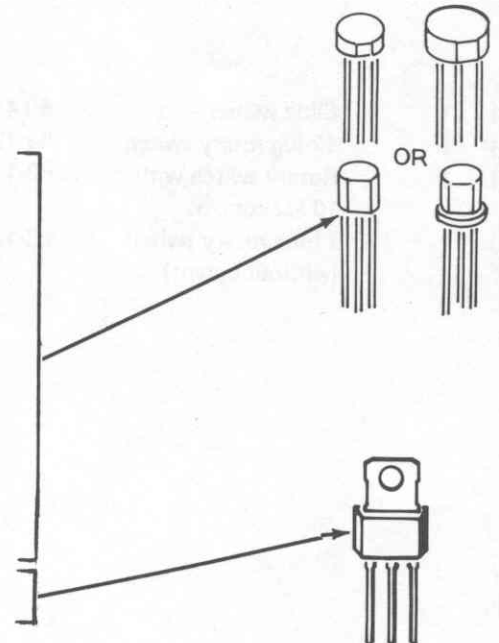

METAL PARTS

() 1	Cabinet top	90-1103-2
() 1	Cabinet bottom	90-1127-2
() 1	Chassis	200-1204
() 1	Front panel	203-1629-1
() 1	Rear panel	203-1630-1
() 1	Upper window bracket	204-1937
() 1	Light bracket	204-1978
() 1	Lower window bracket	204-1986
() 1	Center bracket	204-2008
() 1	Side bracket	204-2017
() 1	"Heathkit" nameplate	205-1448-4
() 2	Trim plate	205-1576
() 2	Side panel	205-1579
() 1	Access panel	205-1580
() 1	CRT shield	206-304
() 1	RF shield	206-1132
() 2	CRT clamp	207-1
() 4	Heat sink	215-85
() 1	Lamp holder	266-824
() 1	7-7/8" shaft	453-102

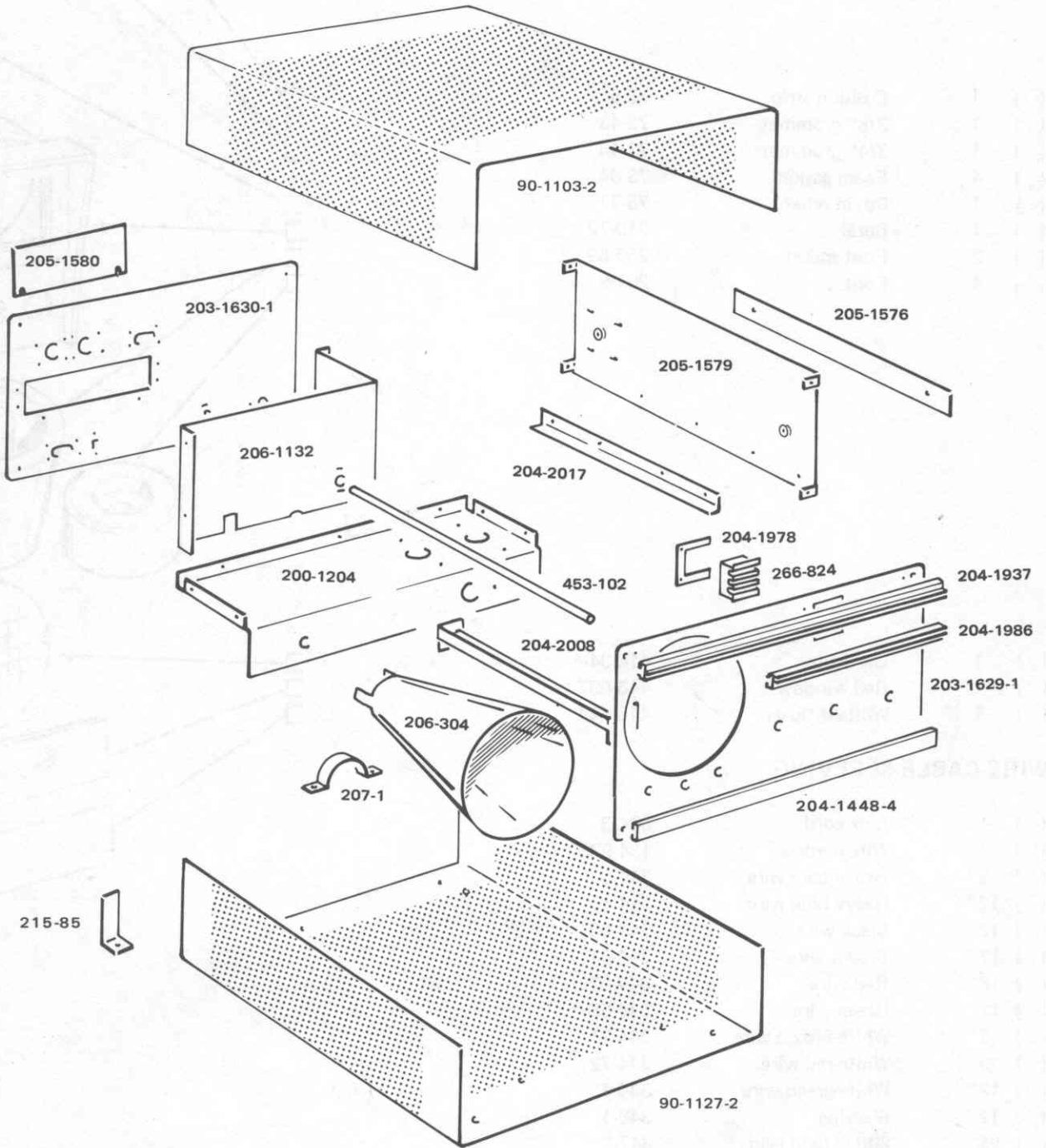

QTY.	DESCRIPTION	PART No.	CIRCUIT Component No.
------	-------------	----------	-----------------------

PLASTIC PARTS

()	1	Cushion strip	73-5
()	1	3/8" grommet	73-43
()	1	3/4" grommet	73-44
()	4	Foam gasket	73-64
()	1	Strain relief	75-71
()	1	Bezel	210-72
()	2	Foot spacer	255-59
()	4	Foot	261-9

()	1	Graticule	414-34-1
()	1	Red window	446-637-1
()	1	White diffuser	446-644

WIRE-CABLE-SLEEVING

()	1	Line cord	89-23
()	1	Wire harness	134-938
()	2"	Heavy bare wire	340-3
()	12"	Heavy blue wire	344-13
()	12"	Black wire	344-50
()	12"	Brown wire	344-51
()	18"	Red wire	344-52
()	12"	Green wire	344-55
()	12"	White-brown wire	344-71
()	18"	White-red wire	344-72
()	12"	White-green wire	344-75
()	12"	Sleeving	346-1
()	24"	300 Ω twin lead	347-2

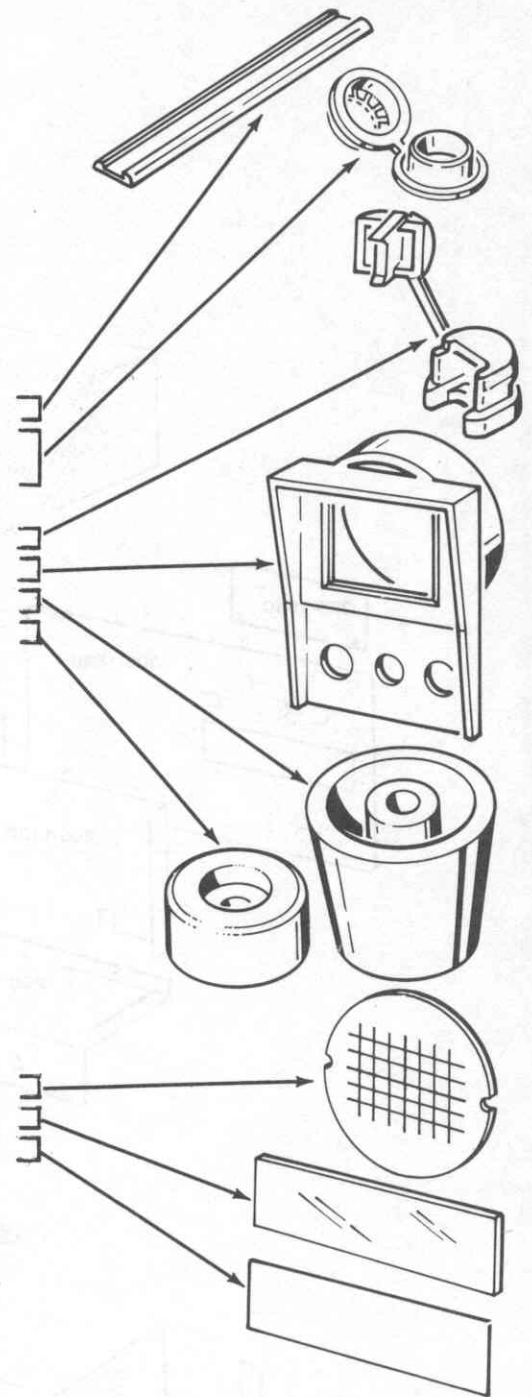

QTY.	DESCRIPTION	PART No.	CIRCUIT Component No.
------	-------------	----------	-----------------------

HARDWARE
#4 Hardware

() 4	4-40 x 1/4" screw	250-52	
() 8	4-40 x 5/16" screw	250-213	
() 8	4-40 x 1/2" T-bolt	250-1194	
() 4	4-40 x 5/8" screw	250-323	
() 28	4-40 nut	252-15	
() 33	#4 lockwasher	254-9	

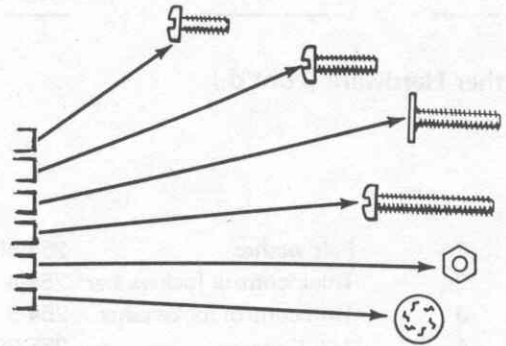
#6 Hardware

() 2	6-32 x 1/8" setscrew	250-33	
() 35	6-32 x 5/16" screw	250-587	
() 11	#6 self-tapping screw	250-8	
() 6	6-32 x 3/8" flat head screw	250-32	
() 4	6-32 x 1/2" screw	250-162	
() 2	6-32 x 1-3/8" screw	250-168	
() 39	6-32 nut	252-3	
() 47	#6 lockwasher	254-1	
() 2	6-32 x 1-3/4" spacer	255-708	
() 2	#6 solder lug	259-1	

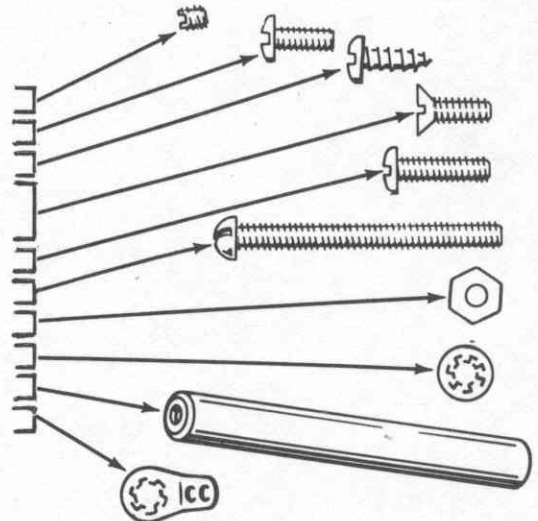
#8 Hardware

() 3	8-32 x 1/4" setscrew	250-43	
() 4	8-32 x 3/8" screw	250-137	
() 4	8-32 nut	252-4	
() 4	#8 lockwasher	254-2	

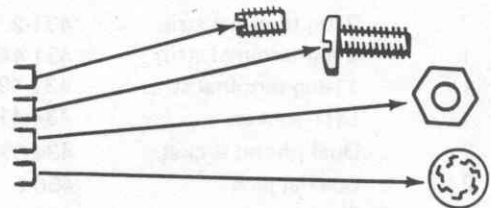
Other Hardware

() 4	10-32 x 1/2" screw	250-456	
() 7	Control nut	252-7	
() 4	Control flat washer	253-10	
() 8	3/4" flat washer	253-19	

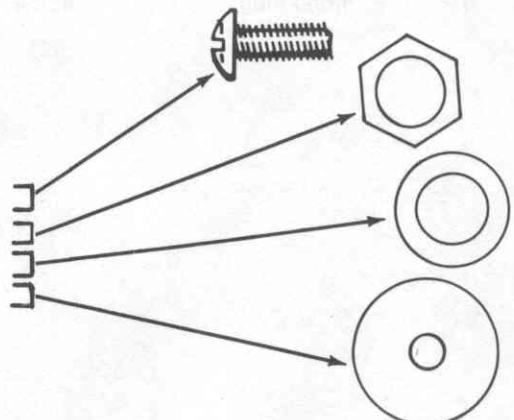

QTY.	DESCRIPTION	PART No.	CIRCUIT Component No.
------	-------------	----------	-----------------------

Other Hardware (cont'd.)

(✓)	2	Felt washer	253-85
()	2	Thick control lockwasher	254-4
()	3	Thin control lockwasher	254-5
()	4	7/32" spacer	255-29
(✓)	1	1-5/8" control spacer	255-126
(✓)	3	Control solder lug	259-10

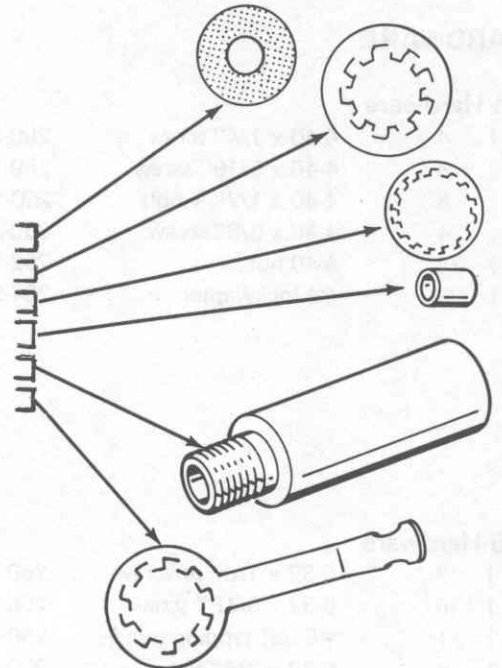

TERMINAL STRIPS-SOCKETS-PLUGS

()	2	2-lug terminal strip	431-2
()	1	4-lug terminal strip	431-44
()	1	11-lug terminal strip	431-49
()	1	CRT socket	434-41
()	2	Dual phono socket	434-82
()	2	Coaxial jack	436-5
()	4	Phono plug	438-4

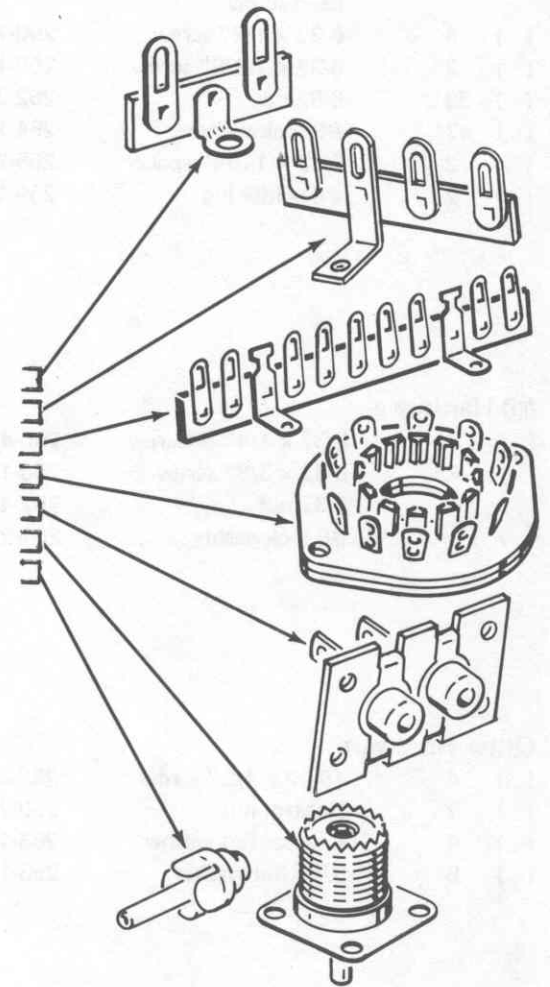

QTY.	DESCRIPTION	PART No.	CIRCUIT Component No.
------	-------------	----------	-----------------------

KNOB-KNOB INSERTS-COUPLERS

() 3	Small round knob	462-932	
() 3	Large round knob	462-933	
() 3	Lever knob	462-935	
() 3	Brass bushing	455-11	
() 3	Long knob insert	455-633	
() 3	Short knob insert	455-52	
() 1	Shaft coupler	456-34	
() 1	Rubber shaft coupler	456-35	

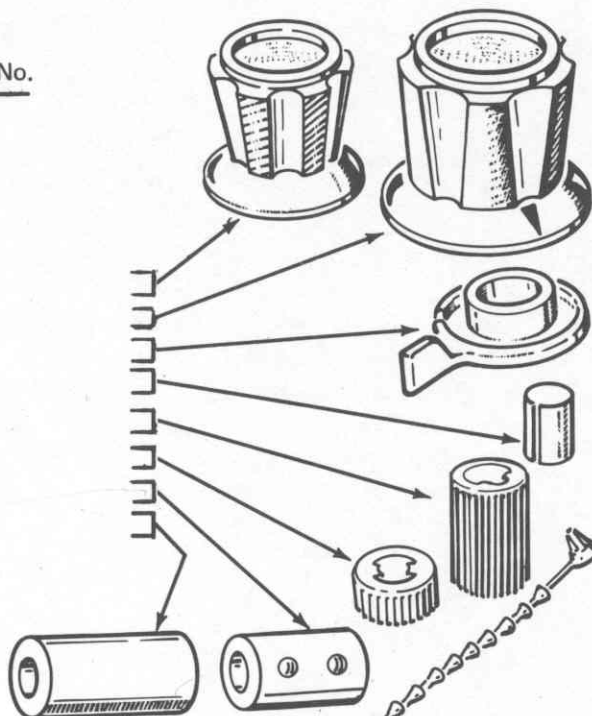

MISCELLANEOUS

() 1	Paper insulator	75-108	
() 1	Demodulator circuit board	85-1518-2	
() 1	Main circuit board	85-1519-2	
() 2	Wire tie	354-6	
() 1	3RP1/A CRT	411-142	V1
() 3	H2-A lamp	412-99	I1, I2, I3
() 1	1/2-ampere slow-fuse	421-20	F1
() 1	Fuseholder	422-1	
() 1	"Danger" label	390-147	
() 1	Fuse label	390-1255	
() 1	Blue and white label	391-34	
() 1	Silicone grease	352-13	
() 1	Nut starter	490-5	
() 1	Parts Order Form	597-260	
() 1	Kit Builders Guide	597-308	
() 1	Assembly manual (See front cover for part number.)		
()	Solder		

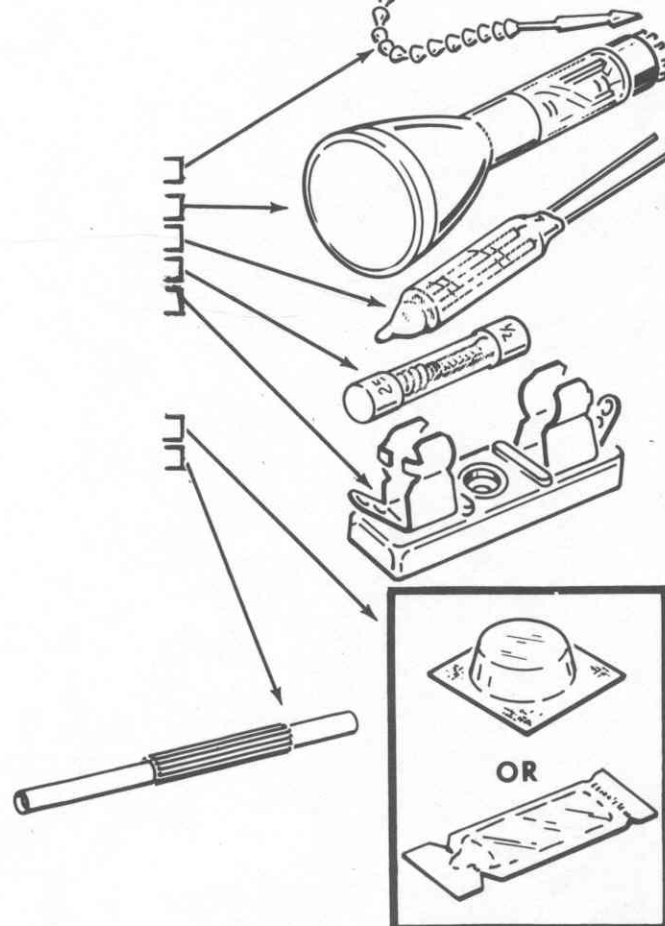

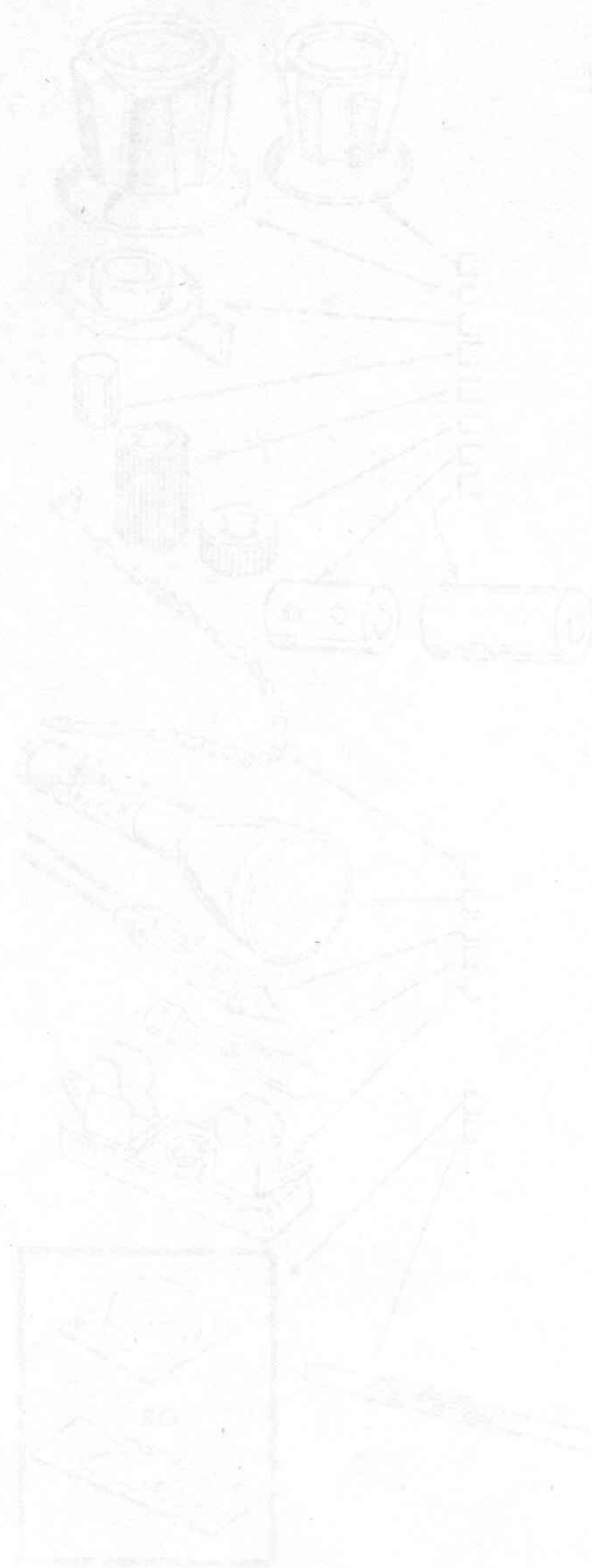

Part No.	Description	Qty
100-001	Power Transformer	1
100-002	Rectifier Bridge	1
100-003	Filter Capacitor	1
100-004	Electrolytic Capacitor	2
100-005	Diode	4
100-006	Resistor	1
100-007	Resistor	1
100-008	Resistor	1
100-009	Resistor	1
100-010	Resistor	1
100-011	Resistor	1
100-012	Resistor	1
100-013	Resistor	1
100-014	Resistor	1
100-015	Resistor	1
100-016	Resistor	1
100-017	Resistor	1
100-018	Resistor	1
100-019	Resistor	1
100-020	Resistor	1
100-021	Resistor	1
100-022	Resistor	1
100-023	Resistor	1
100-024	Resistor	1
100-025	Resistor	1
100-026	Resistor	1
100-027	Resistor	1
100-028	Resistor	1
100-029	Resistor	1
100-030	Resistor	1
100-031	Resistor	1
100-032	Resistor	1
100-033	Resistor	1
100-034	Resistor	1
100-035	Resistor	1
100-036	Resistor	1
100-037	Resistor	1
100-038	Resistor	1
100-039	Resistor	1
100-040	Resistor	1
100-041	Resistor	1
100-042	Resistor	1
100-043	Resistor	1
100-044	Resistor	1
100-045	Resistor	1
100-046	Resistor	1
100-047	Resistor	1
100-048	Resistor	1
100-049	Resistor	1
100-050	Resistor	1
100-051	Resistor	1
100-052	Resistor	1
100-053	Resistor	1
100-054	Resistor	1
100-055	Resistor	1
100-056	Resistor	1
100-057	Resistor	1
100-058	Resistor	1
100-059	Resistor	1
100-060	Resistor	1
100-061	Resistor	1
100-062	Resistor	1
100-063	Resistor	1
100-064	Resistor	1
100-065	Resistor	1
100-066	Resistor	1
100-067	Resistor	1
100-068	Resistor	1
100-069	Resistor	1
100-070	Resistor	1
100-071	Resistor	1
100-072	Resistor	1
100-073	Resistor	1
100-074	Resistor	1
100-075	Resistor	1
100-076	Resistor	1
100-077	Resistor	1
100-078	Resistor	1
100-079	Resistor	1
100-080	Resistor	1
100-081	Resistor	1
100-082	Resistor	1
100-083	Resistor	1
100-084	Resistor	1
100-085	Resistor	1
100-086	Resistor	1
100-087	Resistor	1
100-088	Resistor	1
100-089	Resistor	1
100-090	Resistor	1
100-091	Resistor	1
100-092	Resistor	1
100-093	Resistor	1
100-094	Resistor	1
100-095	Resistor	1
100-096	Resistor	1
100-097	Resistor	1
100-098	Resistor	1
100-099	Resistor	1
100-100	Resistor	1

STEP-BY-STEP ASSEMBLY

ASSEMBLY NOTES

Before you start to assemble this kit, read the "Kit Builders Guide" for complete information on wiring, soldering, and step-by-step assembly procedures.

When you install parts on the circuit boards in the following circuit board pictorials, position all parts as shown. Follow the instructions carefully and read the entire step before you perform each operation.

Use 1/2-watt, 10% (fourth band silver) resistors unless directed otherwise in a step. Resistors will be designated by the color code and the resistance value in Ω (ohms), $k\Omega$ (kilohms), or $M\Omega$ (Megohms).

Capacitors will be designated by the capacitance value and type. Before you install a disc capacitor, remove from its leads any excess body coating material which would protrude through the circuit board and prevent well-soldered connections to the foil.

Always tighten hardware when it is installed unless you are instructed otherwise.

The "component" side of a circuit board has the outlines of the parts printed on it; the "foil" side is the other side. Identify each circuit board by its part number. This number is listed in the parts list and is printed on the component side of each circuit board. Position the boards foil-side-down as shown in the Pictorials. When a circuit board is finished, set it aside until it is called for later in the assembly instructions.

Due to the small foil area around some circuit board holes and small spaces between some foil leads, use care to prevent solder bridges between adjacent foil areas. Use a minimum amount of solder and do not heat components excessively with the soldering iron.

CIRCUIT BOARDS

DEMODULATOR CIRCUIT BOARD

START

Position the demodulator circuit board as shown. Then proceed with the following steps.

NOTE: As you install diodes on this Pictorial, be sure to position the banded end of each diode on the circuit board as shown.

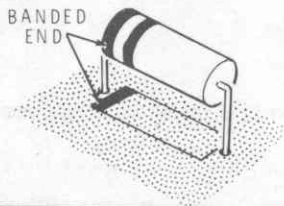

() D201. 1N191 diode (brown-white-brown, #56-26).

() R202. 15 kΩ (brown-green-orange).

() R201. 1500 Ω, 2-watt (brown-green-red). Position this resistor 1/8" above the circuit board.

() R203. 18 kΩ, 1-watt (brown-gray-orange).

() D202. 1N191 diode (brown-white-brown, #56-26). Position the banded end as shown.

() D203. 1N191 diode (brown-white-brown, #56-26). Position the banded end as shown.

() R204. 3.3 MΩ (orange-orange-green).

() R205. 220 Ω (red-red-brown).

() R207. 10 kΩ (brown-black-orange).

() D204. 1N191 diode (brown-white-brown, #56-26). Position the banded end as shown.

() R206. 18 kΩ (brown-gray-orange).

SAFETY WARNING: Avoid eye injury when you cut off excess lead lengths. Hold the leads so they cannot fly toward your eyes.

() Solder the leads to the foil and cut off the excess lead lengths.

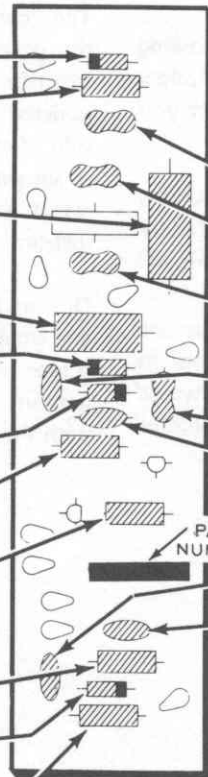

CONTINUE

NOTE: Check the leads of each disc or mica capacitor as you install it. Remove the coating from each capacitor as shown. This coating could cause a bad solder connection.

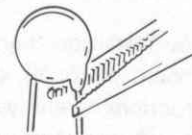

REMOVE COATING EVEN WITH BOTTOM OF CAPACITOR BODY

() C203. 300 pF mica.

() C202. 100 pF mica.

() C201. 100 pF mica.

() C204. .001 μF disc.

() C205. .001 μF (1000 pF) mica.

() C206. .2 μF disc.

() C207. 470 pF disc.

() C208. .001 μF disc.

() Solder the leads to the foil and cut off the excess lead lengths.

NOTE: Save several cut-off capacitor leads for use as jumpers in following steps.

FOR GOOD SOLDER CONNECTIONS, YOU MUST KEEP THE SOLDERING IRON TIP CLEAN. WIPE IT OFTEN WITH A DAMP SPONGE OR CLOTH.



PICTORIAL 1-1

START ↩

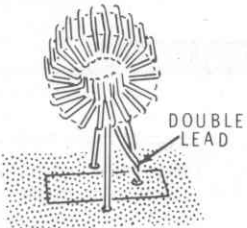

() L201. Mount the toroid coil (#40-1736) as shown. Solder the leads to the foil.

NOTE: When you install the following zener diode (transistor), line up the flat on the transistor with the outline of the flat on the circuit board, then insert the leads into their correct E, B, and C holes. Solder the leads to the foil and cut off the excess lead lengths.

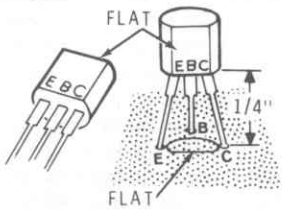

() ZD201. MPSA20 transistor (#417-801).

() Q201. 2N5458 transistor (#417-291). Line up the flat of the transistor with the outline of the flat on the circuit board. Then insert the leads into their correct S, D, and G holes. Solder the leads to the foil and cut off their excess lead lengths.

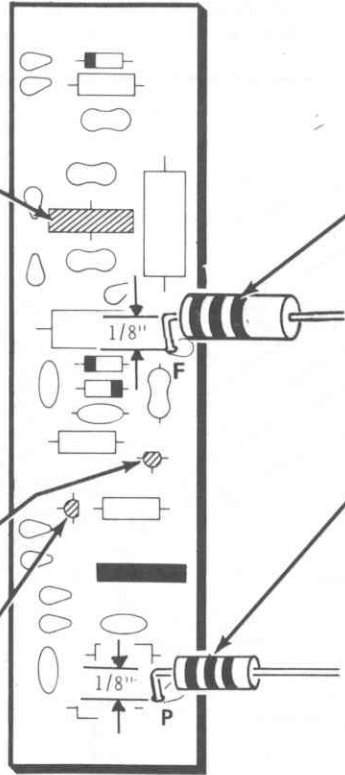
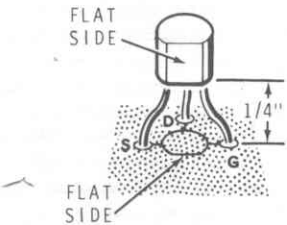

CONTINUE ◀

() Cut one lead of a 47 kΩ, 2-watt (yellow-violet-orange) resistor to 1/2".

() R1. Mount this resistor at F on the circuit board, as shown, so the resistor is 1/8" above the board. Solder the lead to the foil and cut off any excess lead length.



() Cut one lead of a 47 kΩ, 1-watt (yellow-violet-orange) resistor to 1/2".

() R2. Mount this resistor at P on the circuit board, as shown, so the resistor is 1/8" above the board. Solder the lead to the foil and cut off any excess lead length.

CIRCUIT BOARD CHECKOUT

Carefully inspect the circuit board for the following conditions.

- () Unsoldered connections.
- () "Cold" solder connections.
- () Solder bridges between foil patterns.
- () Protruding leads which could touch together.
- () Transistors for the proper type and installation.
- () Diodes for the correct position of the banded end.

FINISH

NOTE: There are 11 unsoldered holes on the board at this time.

Set the circuit board aside temporarily.

PICTORIAL 1-2



MAIN CIRCUIT BOARD

IDENTIFICATION
DRAWING

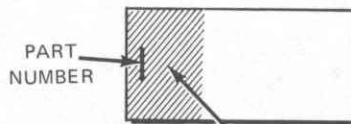

The steps performed in this Pictorial are in this area of the circuit board.

START

Position the main circuit board as shown in the identification drawing. Then proceed with the following steps.

- (✓) R107. 1 MΩ (brown-black-green).
- () R136. 1000 Ω (brown-black-red).
- () R115. 1000 Ω (brown-black-red).
- () R105. 1000 Ω (brown-black-red).
- () R103. 1000 Ω (brown-black-red).
- () R101. 1.5 MΩ (brown-green-green).

() Solder the leads to the foil and cut off the excess lead lengths.

- () R102. 5.6 MΩ (green-blue-green).
- () R106. 4700 Ω (yellow-violet-red).
- () R104. 4700 Ω (yellow-violet-red).
- () R112. 1000 Ω (brown-black-red).
- () R109. 1 MΩ (brown-black-green).
- () R111. 10 MΩ (brown-black-blue).
- () R121. 4700 Ω (yellow-violet-red).

() 3/4" bare wire at "J". Use a cutoff capacitor lead.

FOR GOOD SOLDER CONNECTIONS, YOU MUST KEEP THE SOLDERING IRON TIP CLEAN.

WIPE IT OFTEN WITH A DAMP SPONGE OR CLOTH.



() Solder the leads to the foil and cut off the excess lead lengths.

CONTINUE

- () 3/4" bare wire at "J". Use a cutoff capacitor lead.
- () R127. 1000 Ω (brown-black-red).
- () R129. 1000 Ω (brown-black-red).
- () R131. 100 Ω (brown-black-brown).
- () R132. 100 Ω (brown-black-brown).
- () 3/4" bare wire at "J". Use a cutoff capacitor lead.
- () R123. 470 Ω (yellow-violet-brown).
- () R137. 1000 Ω (brown-black-red).
- () R124. 1000 Ω (brown-black-red).
- () Solder the leads to the foil and cut off the excess lead lengths.
- () R122. 100 Ω (brown-black-brown).
- () R118. 1000 Ω (brown-black-red).
- () R117. 470 Ω (yellow-violet-brown).
- () R119. 100 kΩ, 5% (brown-black-yellow).
- () R116. 100 kΩ, 5% (brown-black-yellow).
- () R144. 1000 Ω (brown-black-red).
- () R114. 1000 Ω (brown-black-red).
- () R143. 100 Ω (brown-black-brown).
- () R142. 100 Ω (brown-black-brown).
- () R141. 1000 Ω (brown-black-red).
- () R138. 1000 Ω (brown-black-red).
- () Solder the leads to the foil and cut off the excess lead lengths.

PICTORIAL 2-1

IDENTIFICATION
DRAWING

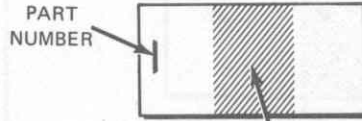

The steps performed in this Pictorial are in this area of the circuit board.

CONTINUE

NOTE: When you are instructed to mount a power resistor 3/16" above the circuit board as shown, use a 1" x 1" piece of 3/16" cardboard (from shipping carton) for a spacer. Solder each resistor as it is installed, cut off the excess lead lengths, and then remove the cardboard spacer.

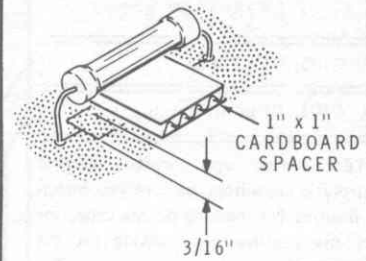

- () R149. 10 kΩ, 7-watt film. Position this resistor 3/16" above the board.
- () R148. 10 kΩ, 7-watt film. Position this resistor 3/16" above the board.
- () R152. 10 kΩ, 7-watt film. Position this resistor 3/16" above the board.
- () R151. 10 kΩ, 7-watt film. Position this resistor 3/16" above the board.

NOTE: DIODES MAY BE SUPPLIED IN ANY OF THE FOLLOWING SHAPES. ALWAYS POSITION THE BANDED END AS SHOWN ON THE CIRCUIT BOARD.

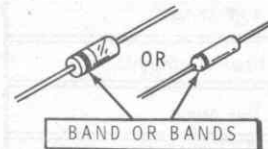

- () ZD103. VR-10A zener diode (#56-67). Solder the leads to the foil and cut off the excess lead lengths.

START

- () R133. 470 Ω (yellow-violet-brown).
 - () R135. 1000 Ω (brown-black-red).
 - () R134. 470 Ω (yellow-violet-brown).
 - () R153. 15 kΩ (brown-green-orange).
 - () Solder the leads to the foil and cut off the excess lead lengths.
- NOTE: To prepare a wire, as in the following step, cut the wire to the indicated length. Then remove 1/4" of insulation from each wire end.
- () Prepare a 2-1/4" red wire. 2-1/4" red wire at "J".
 - () R125. 1.5 MΩ (brown-green-green).
 - () R126. 180 Ω, 5% (brown-gray-brown).
 - () R146. 470 Ω (yellow-violet-brown).
 - () R147. 1000 Ω (brown-black-red).
 - () R145. 470 Ω (yellow-violet-brown).
 - () R157. 1000 Ω (brown-black-red).
 - () R158. 68 Ω (blue-gray-black).
- SAFETY WARNING: Avoid eye injury when you cut off excess lead lengths. Hold the leads so they cannot fly toward your eyes.
- () Solder the leads to the foil and cut off the excess lead lengths.

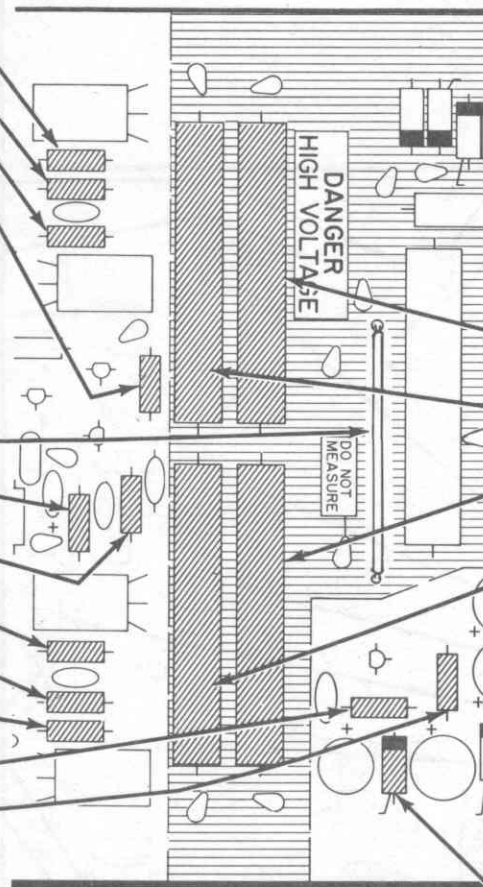

PICTORIAL 2-2



IDENTIFICATION
DRAWING

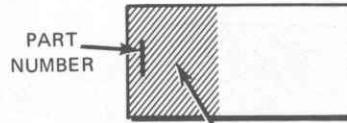

The steps performed in this Pictorial are in this area of the circuit board.

START ▾

NOTE: Check the leads of each disc, mica or Mylar capacitor as you install it. Remove the coating from each capacitor as shown. This coating could cause a bad solder connection.

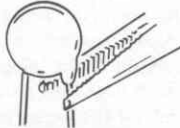

REMOVE COATING EVEN WITH BOTTOM OF CAPACITOR BODY

- () C105. 470 pF disc.
- () C101. .01 μ F (small) disc.

NOTE: When you install vertical electrolytic capacitors, be sure you match the positive (+) marking on the capacitor with the positive (+) marking on the circuit board.

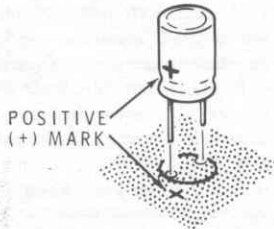

- () C107. 50 μ F electrolytic.
- () C112. 10 μ F electrolytic.
- () C106. 30 pF mica.
- () C109. .1 μ F Mylar.
- () C114. 10 μ F electrolytic.
- () C102. .1 μ F Mylar.
- () C103. .01 μ F disc.
- () C104. 470 pF disc.

() Solder the leads to the foil and cut off the excess lead lengths.

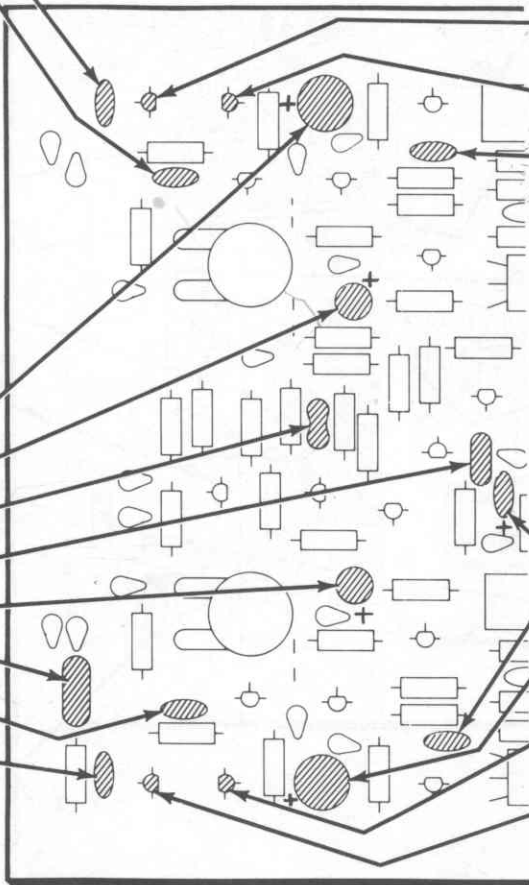

CONTINUE ▾

NOTE: In four steps in this column, transistors will be installed at diode locations. Be sure to match the E, B, and C leads of each transistor with the E, B, and C holes in the circuit board. Press the transistor down to 1/4" above the board. Solder the leads of each transistor as it is mounted; then cut off the excess lead lengths.

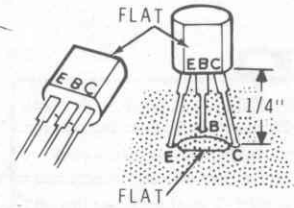

- () D101. MPSA20 transistor (#417-801).
- () D102. MPSA20 transistor (#417-801).
- () C113. 470 pF disc.

NOTE: Tantalum capacitors may be marked two ways as shown. When installing the following capacitors, be sure to match the positive (+) sign or color dot on the capacitor with the positive (+) marking on the circuit board.

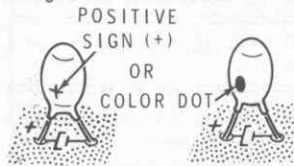

- () C111. 10 μ F tantalum.
- () C115. 470 pF disc.
- () C108. 50 μ F electrolytic. Position the positive (+) mark as shown.
- () D104. MPSA20 transistor (#417-801).
- () D103. MPSA20 transistor (#417-801).
- () Solder all leads to the foil and cut off the excess lead lengths.

PICTORIAL 2-3

START ↘

() R113. 4700 Ω (yellow-violet-red). Solder both leads to the foil. Then, refer to Detail 2-4A (below). Turn the circuit board foil-side-up. Cut off the indicated resistor lead. Bend the other resistor lead over sharply and solder it to the indicated solder pad. Cut off the excess lead lengths.

IDENTIFICATION
DRAWING

PART
NUMBER



The steps performed in this Pictorial are in this area of the circuit board.

NOTE: Install the four transistors in this column as shown. Solder the leads to the foil and cut off the excess lead lengths.
NOTE: Center transistor leads may be bent either forward or rearward (as shown). Carefully study circuit board.

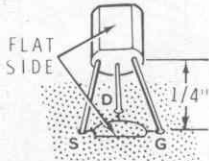

() Q102. MPF105 transistor (#417-169).

() Q101. MPF105 transistor (#417-169).

As you install the control in each of the next two steps, solder its four lugs to the foil.

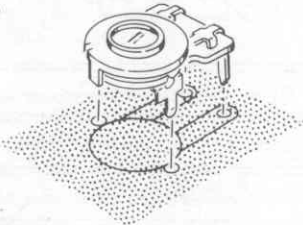

() R128. 500 Ω control (#10-381).

() R139. 500 Ω control (#10-381).

NOTE: Bend the center (D) leads forward on the transistors in the next two steps.

() Q115. MPF105 transistor (#417-169). (See the illustration at the top of this column.) Bend the center lead forward.

() Q116. MPF105 transistor (#417-169). (See the illustration at the top of this column.) Bend the center lead forward.

CONTINUE ↘

NOTE: Install each of the following transistors as shown. Solder each lead to the foil and cut off the excess lead lengths.

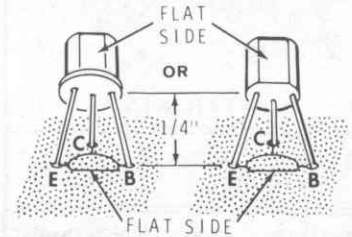

() Q103. 2N5232A transistor (#417-91). Bend the center lead forward.

() Q105. 2N5232A transistor (#417-91).

() Q107. MPSA20 transistor (#417-801).

() Q108. MPSA20 transistor (#417-801).

() Q111. X29A829 transistor (#417-201).

() Q109. X29A829 transistor (#417-201).

() Q119. 2N5232A transistor (#417-91). Bend the center lead forward.

() Q117. 2N5232A transistor (#417-91).

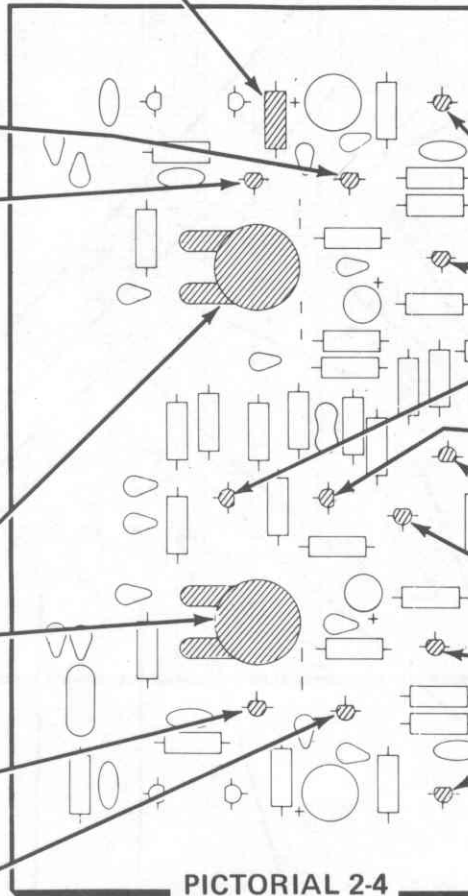

PICTORIAL 2-4

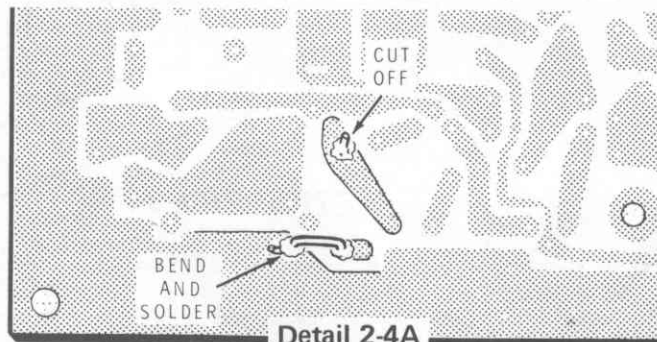

Detail 2-4A

START

() C117. 470 pF disc.

NOTE: When you install the following transistors, line up the flat on each transistor with the outline of the flat on the circuit board. Then insert the leads into their correct E, C, and B holes. Solder the leads to the foil and cut off the excess lead lengths.

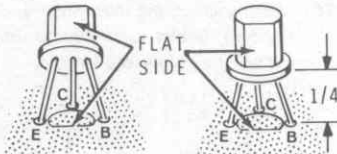

DETAIL 2-4A

() Q113. X29A829 transistor (#417-201).

() Q112. X29A829 transistor (#417-201).

NOTE: Install the following transistor as shown. Solder each lead to the foil and cut off the excess lead lengths.

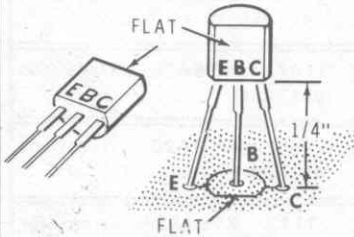

() Q114. MPSA42 transistor (#417-294).

() C116. .0033 μ F (3300 pF) disc.

() C119. .01 μ F, 1.6 kV disc.

() C118. 470 pF disc.

() Q122. 2N3416 transistor (#417-94) (See Detail 2-4A above).

() Solder the leads to the foil and cut off the excess lead lengths.

IDENTIFICATION DRAWING

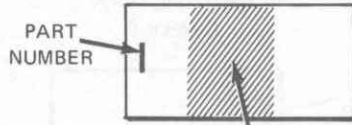

The steps performed in this Pictorial are in this area of the circuit board.

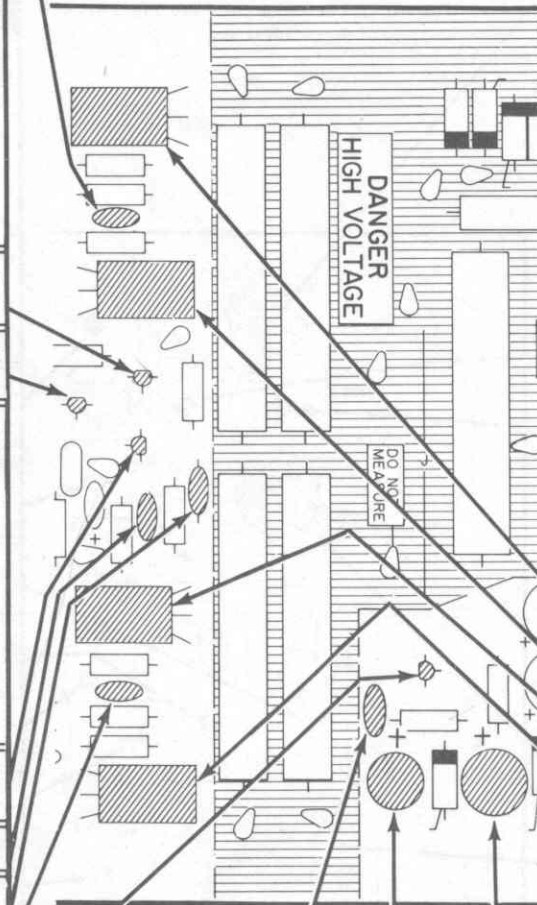

CONTINUE

() Form the leads of four MPSU10 transistors (#417-834) as shown. Then open the grease pod and apply a liberal amount of silicone grease to each of the four heat sinks as shown.

Mount a heat sink and a transistor at each of the following locations with 4-40 x 1/4" hardware. Then solder the transistor leads to the foil and cut off the excess lead lengths.

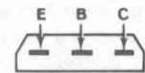
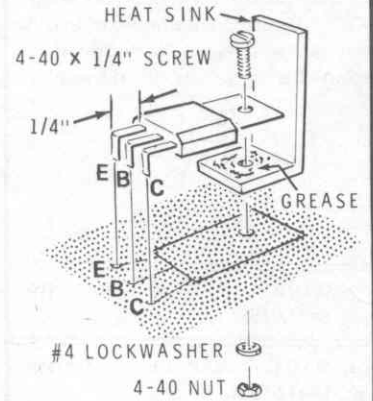

(BASE VIEW)

() Q104. MPSU10 transistor assembly.

() Q106. MPSU10 transistor assembly.

() Q121. MPSU10 transistor assembly.

() Q118. MPSU10 transistor assembly.

NOTE: When you install vertical electrolytic capacitors, be sure you match the positive (+) marking on the capacitor with the positive (+) marking on the circuit board.

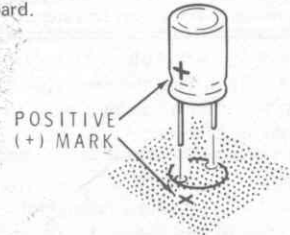

() C127. 250 μ F electrolytic. Position the positive (+) mark as shown.

() C126. 50 μ F electrolytic. Position the positive (+) mark as shown.

() C125. .001 μ F disc.

() Solder the leads to the foil and cut off the excess lead lengths.

PICTORIAL 2-5

START →

NOTE: DIODES MAY BE SUPPLIED IN ANY OF THE FOLLOWING SHAPES. ALWAYS POSITION THE BANDED END AS SHOWN ON THE CIRCUIT BOARD.

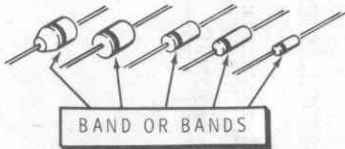

- () D111. 1N2071 diode (#57-27).
- () D113. 1N2071 diode (#57-27).
- () D112. 1N2071 diode (#57-27).
- () D109. 1N2071 diode (#57-27).
- () R156. 100 Ω, 1-watt (brown-black-brown).

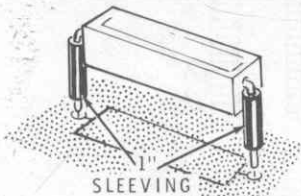

- () R155. 2000 Ω (2K), 10-watt, wire-wound resistor. Use 1" of sleeving on each lead and position the resistor leads straight up from the board.

- () ZD101. BZT110A zener (#56-48).
- () ZD102. ZVR-68 zener (#56-68).

NOTE: When you install vertical electrolytic capacitors, be sure you match the positive (+) marking on the capacitor with the positive (+) marking on the circuit board.

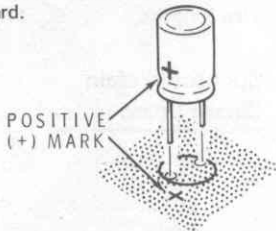

- () C131. 250 μF electrolytic.
- () C129. 250 μF electrolytic.
- () Solder the leads to the foil and cut off the excess lead lengths.

IDENTIFICATION DRAWING

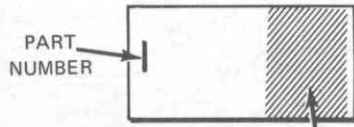

The steps performed in this Pictorial are in this area of the circuit board.

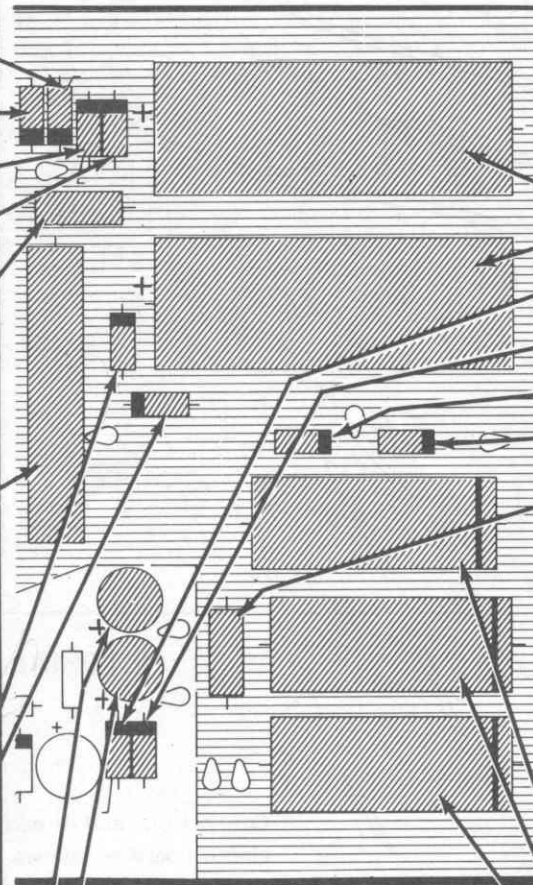

CONTINUE →

NOTE: When you install an electrolytic capacitor, always match the positive (+) marked end of the capacitor with the positive (+) mark on the circuit board.

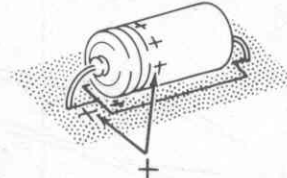

- () C128. 70 μF electrolytic.
- () C124. 70 μF electrolytic.
- () D107. 1N4002 diode (#57-65).
- () D108. 1N4002 diode (#57-65).
- () D105. D0-7 diode (#57-52).
- () D106. D0-7 diode (#57-52).
- () R154. 470 kΩ, 1-watt (yellow-violet-yellow).

NOTE: When you install each of the following three capacitors, always match the banded end of the capacitor with the band mark on the circuit board.

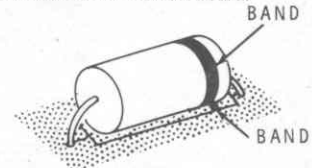

- () C122. .1 μF, 1.6 kV capacitor.
- () C123. .1 μF, 1.6 kV capacitor.
- () C121. .1 μF, 1.6 kV capacitor.
- () Solder the leads to the foil and cut off the excess lead lengths.

FINISH

PICTORIAL 2-6

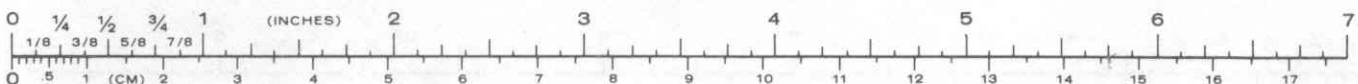

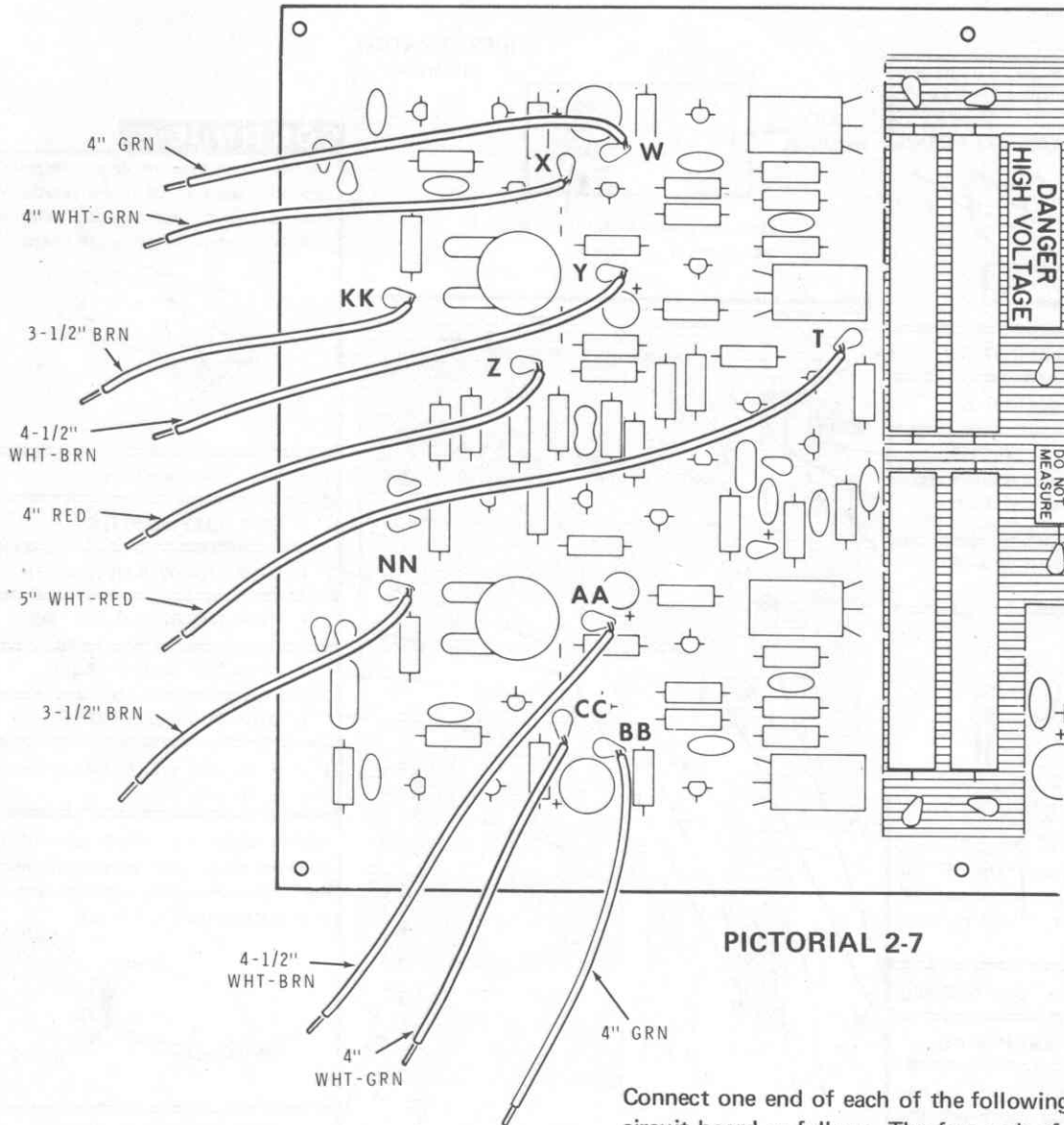

PICTORIAL 2-7

Connect one end of each of the following wires to the main circuit board as follows. The free ends of these wires will be connected later. Solder each wire to the circuit board foil as it is installed; cut off any excess wire lengths.

Refer to Pictorial 2-7 for the following steps.

() Prepare the following lengths of hookup wire. Cut the wire to the length indicated; then remove 1/4" of insulation from each wire end.

- 5" white-red
- 4" green
- 4" green
- 4-1/2" white-brown
- 4-1/2" white-brown
- 4" white-green
- 4" white-green
- 4" red
- 3-1/2" brown
- 3-1/2" brown

Wire Color and Length	Connect to Main Circuit Board Hole
() 5" white-red	T
() 4" green	W
() 4" green	BB
() 4-1/2" white-brown	Y
() 4-1/2" white-brown	AA
() 4" white-green	X
() 4" white-green	CC
() 4" red	Z
() 3-1/2" brown	KK
() 3-1/2" brown	NN

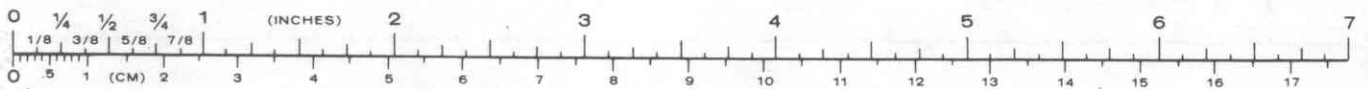

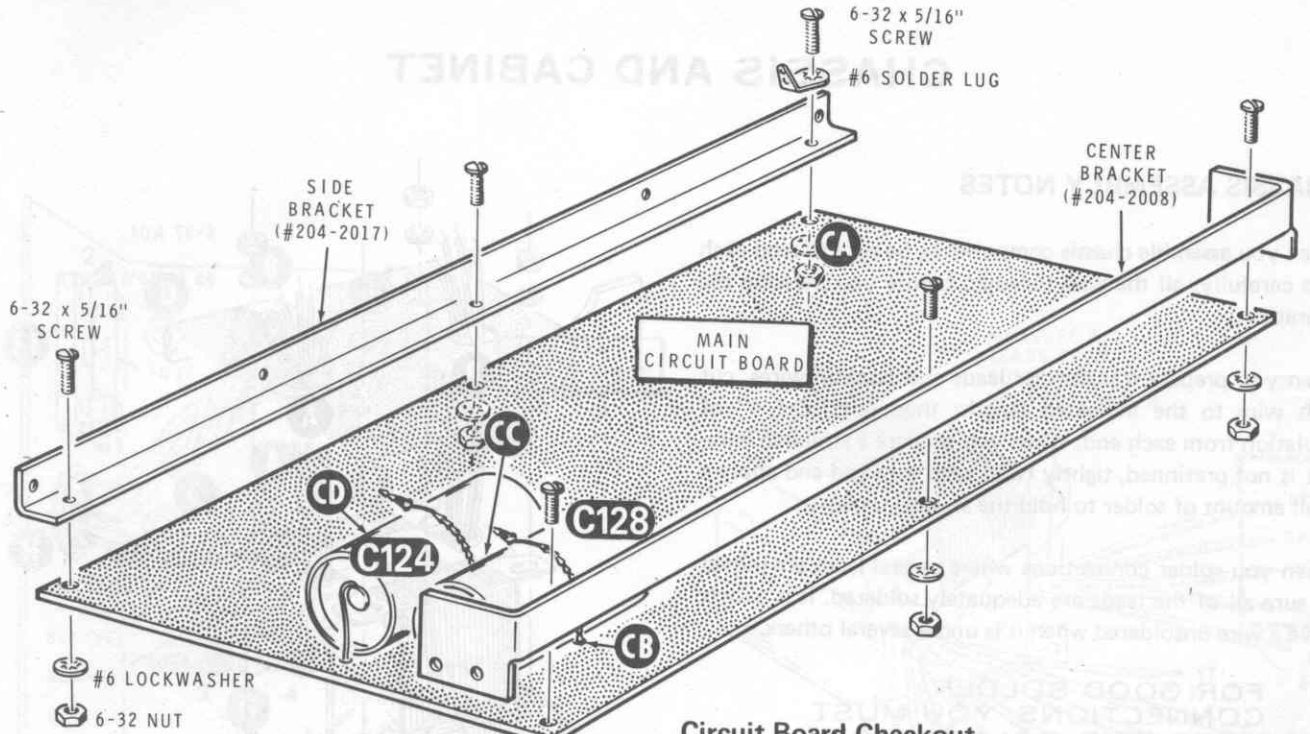

PICTORIAL 2-8

Refer to Pictorial 2-8 for the following steps.

NOTE: When hardware is called for in a step, only the screw size will be given. For instance, if "6-32 x 3/8" hardware is called for, it means that a 6-32 x 3/8" screw, one or more #6 lockwashers, and a 6-32 nut should be used for each mounting hole. Refer to the illustrations for the proper number of lockwashers to use. Use the plastic nut starter to hold and start 6-32 and 4-40 nuts on screws.

- () Position the main circuit board as shown. Then mount the side bracket (#204-2017) on the indicated side of the board with 6-32 x 5/16" hardware. Place a #6 solder lug under the screw head at CA and position it as shown. Tighten the nuts finger tight.
- () Similarly, mount the center bracket on the other side of the circuit board. Use 6-32 x 5/16" hardware. Tighten the nuts finger tight.
- () Refer to Detail 2-8A, and pass the pointed end of a cable tie downward through hole CC (between capacitors C124 and C128), across the underside of the main circuit board, and upward through hole CB. Pull the pointed end of the tie through the loop on the opposite end and pull the tie tightly around capacitor C128. Cut off the excess tie length.
- () In the same manner, pass a cable tie downward through hole CD, upward through hole CC, and tighten it securely around capacitor C124. Cut off the excess tie length.

Circuit Board Checkout

Carefully inspect the circuit board for the following conditions.

- () Unsoldered connections.
- () "Cold" solder connections.
- () Solder bridges between foil patterns.
- () Protruding leads which could touch together.
- () Transistors for proper type and installation.
- () Electrolytic capacitors for the correct position of the positive (+) end.
- () Diodes for the correct position of the banded end.

Set the main circuit board aside temporarily.

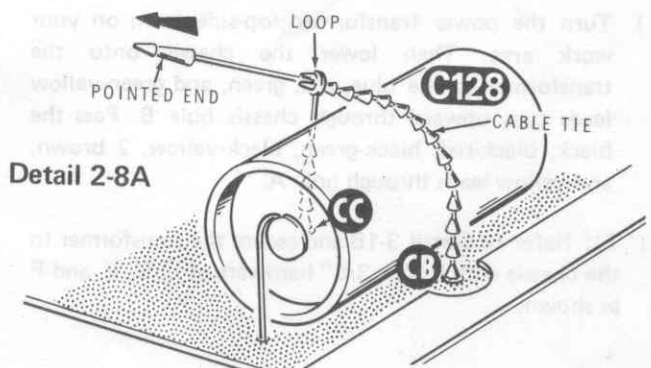

Detail 2-8A

CHASSIS AND CABINET

CHASSIS ASSEMBLY NOTES

When you assemble chassis components, be sure to read each step carefully, all the way through, before you perform the operation.

When you prepare transformer leads and hookup wires, cut each wire to the indicated length; then remove 1/4" of insulation from each end. When you prepare a stranded wire, if it is not pretinned, tightly twist each wire end and apply a small amount of solder to hold the strands together.

When you solder connections where several leads are joined, be sure all of the leads are adequately soldered. It is easy to leave a wire unsoldered when it is under several others.

FOR GOOD SOLDER CONNECTIONS, YOU MUST KEEP THE SOLDERING IRON TIP CLEAN.

WIPE IT OFTEN WITH A DAMP SPONGE OR CLOTH.

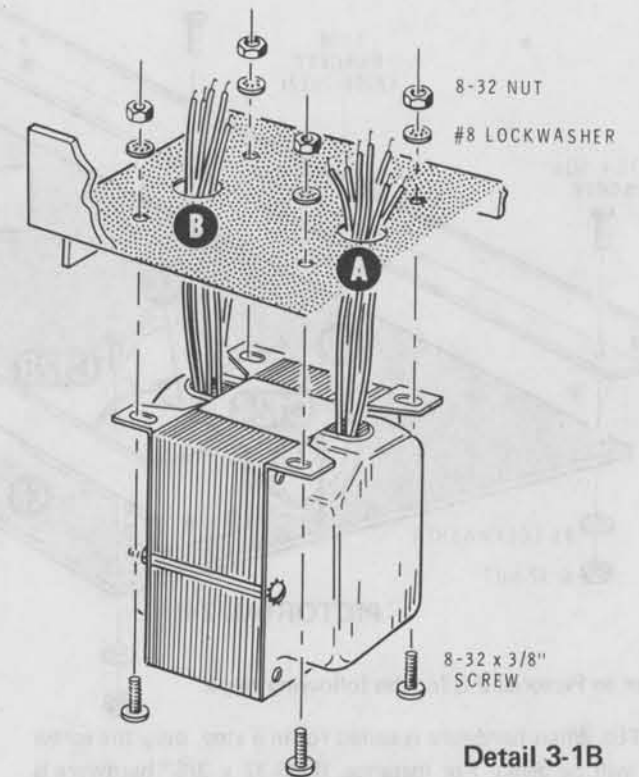

Detail 3-1B

- () Refer to Detail 3-1C and mount the fuseholder at F1 on the chassis with 6-32 x 5/16" hardware.

NOTE: In the following step, fuse F1 will be installed in the fuseholder. If your kit will be wired for 110-130 VAC, use the fuse furnished with the kit; if it will be wired for 220-240 VAC, a 1/4-ampere, 3AG, slow-blow fuse must be purchased.

- () F1: Press the 1/2-ampere slow-blow fuse into fuseholder F1 (use a 1/4-ampere slow-blow fuse for the higher line voltage).

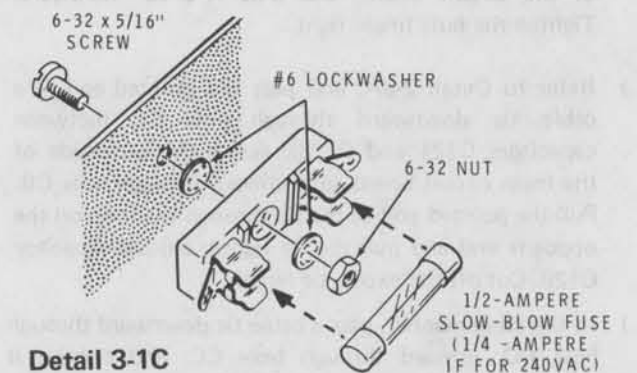

Detail 3-1C

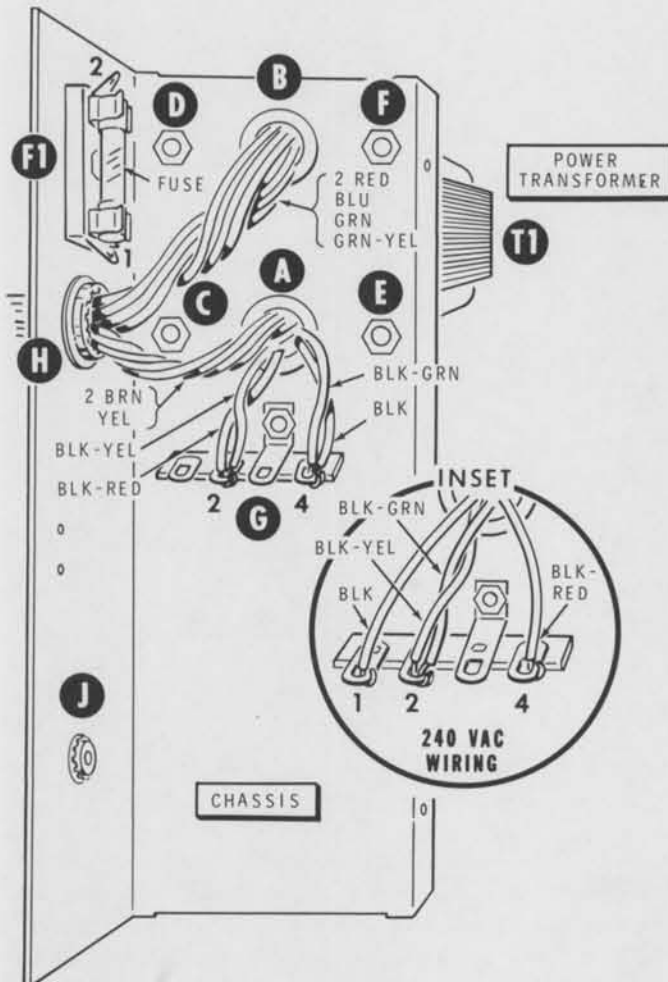

PICTORIAL 3-1

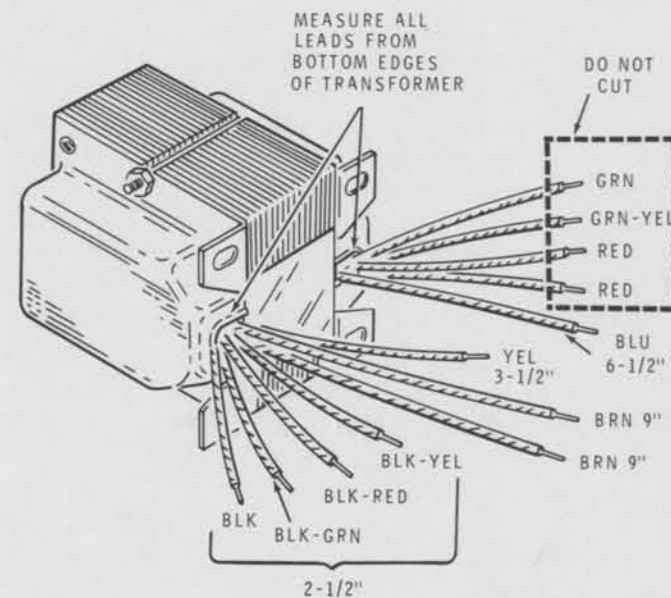

Detail 3-1A

CHASSIS

Refer to Pictorial 3-1 for the following steps.

- () Refer to Detail 3-1A and cut each of the power transformer leads as follows:

Green — do not cut	Yellow — 3-1/2"
Both red — do not cut	Black — 2-1/2"
Green-yellow — do not cut	Black-green — 2-1/2"
Both brown — 9"	Black-red — 2-1/2"
Blue — 6-1/2"	Black-yellow — 2-1/2"

NOTE: Save the cutoff transformer leads; some of them will be used later.

- () Turn the power transformer top-side-down on your work area. Then lower the chassis onto the transformer so the blue, red, green, and green-yellow leads pass upward through chassis hole B. Pass the black, black-red, black-green, black-yellow, 2 brown, and yellow leads through hole A.

- () T1: Refer to Detail 3-1B and secure the transformer to the chassis with 8-32 x 3/8" hardware at C, D, E, and F as shown.

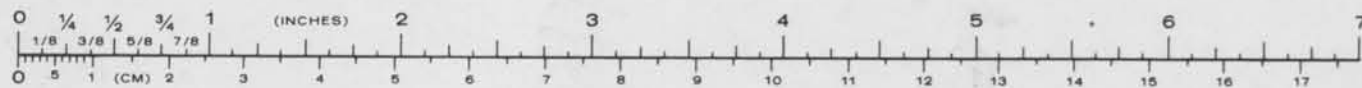

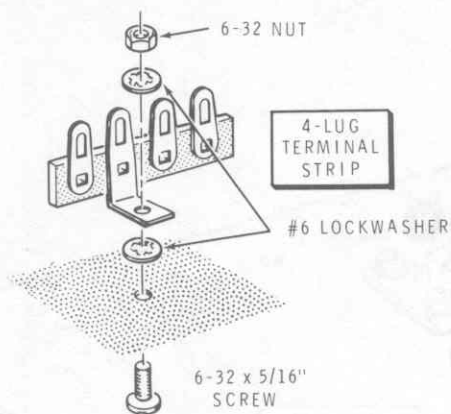

Detail 3-1D

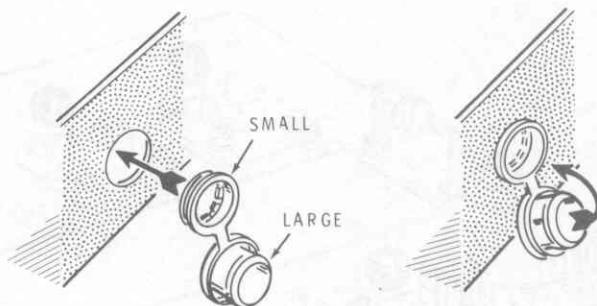

POSITION THE SMALL PORTION OF THE GROMMET INTO THE CHASSIS HOLE.

BEND THE LARGE PORTION OF THE GROMMET OVER AND INTO THE SMALL PORTION. PRESS IT FIRMLY INTO PLACE.

Detail 3-1E

- () Refer to Detail 3-1D and mount the 4-lug terminal strip at G with 6-32 x 5/16" hardware. Position the terminal strip as shown in the Pictorial.
- () Refer to Detail 3-1E and press a 3/8" plastic grommet into hole J in the chassis.
- () In the same manner, press a 3/4" plastic grommet into chassis hole H.

Refer to Pictorial 3-1 for the following steps.

- () Twist together the five power transformer leads coming from hole B and pass them through grommet H as shown.
- () Twist together the two brown and the yellow transformer leads coming from hole A and pass them through grommet H as shown.

NOTES:

1. You will be instructed to wire the power transformer in the following steps. If your line voltage is 220-260 VAC, proceed directly to the steps titled "220-260 VAC Wiring" below. Otherwise, do the steps titled "110-130 VAC Wiring."
2. As you connect the power leads to the terminal strip in the following steps, tightly wrap each lead end around its designated lug to assure a good mechanical connection. These connections will be soldered later.
3. In the following steps, (NS) means not to solder because other wires will be added later. "S-" with a number, such as (S-3), means to solder the connection. The number following the "S" tells how many wires are at the connection.

110-130 VAC Wiring

- () Twist the black and the black-green power transformer leads together and connect both lead ends to terminal strip G lug 4 (NS).
- () Twist the black-red and the black-yellow power transformer leads together and connect both lead ends to terminal strip G lug 2 (NS).

Set the chassis aside temporarily.

Proceed to the "Rear Panel" steps.

220-260 VAC Wiring

Refer to the inset drawing on Pictorial 3-1 for the following steps.

- () Connect the black power transformer lead to terminal strip G lug 1 (NS).
- () Twist the black-green and the black-yellow power transformer leads together and connect both lead ends to terminal strip G lug 2 (S-2).
- () Connect the black-red power transformer lead to terminal strip G lug 4 (NS).

Set the chassis aside temporarily.

Proceed to the "Rear Panel" steps.

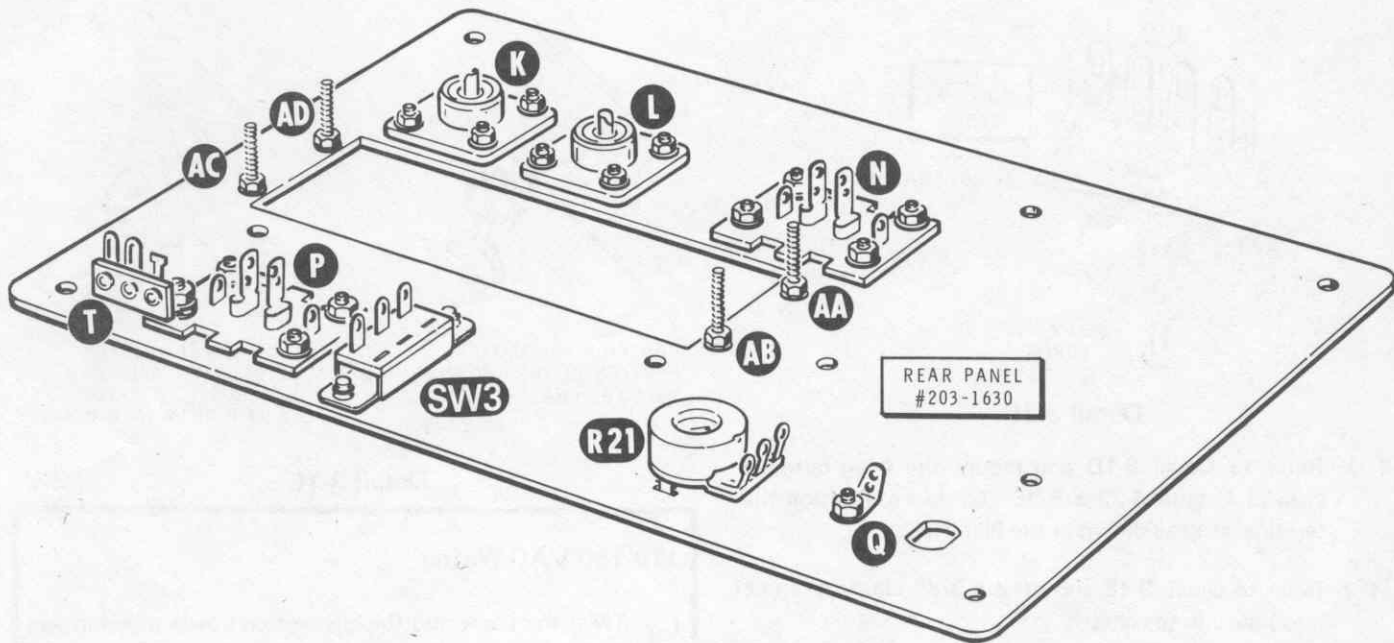

PICTORIAL 3-2

REAR PANEL

Refer to Pictorial 3-2 for the following steps.

- () Refer to Detail 3-2A and mount four 4-40 x 5/8" screws at AA, AB, AC, and AD as shown. Tighten the nuts only finger tight.
- () Refer to Detail 3-2B and mount a coaxial jack at K on the inside of the rear panel as shown. Use 4-40 x 5/16" hardware.
- () In the same manner, mount a coaxial jack at L.

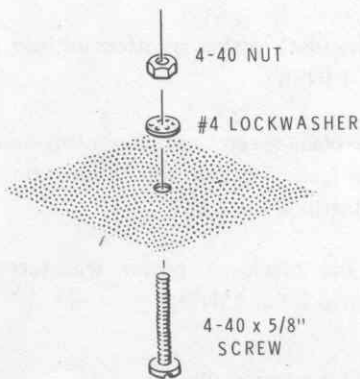

Detail 3-2A

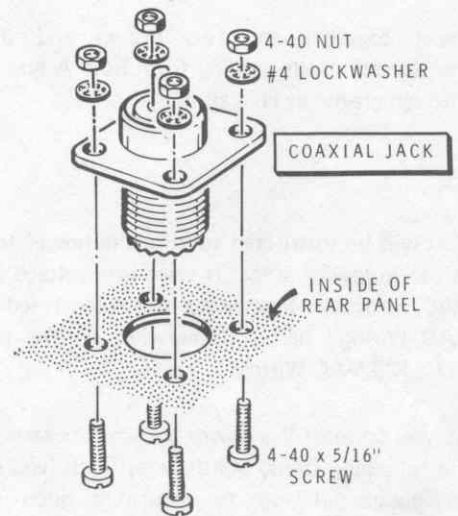

Detail 3-2B

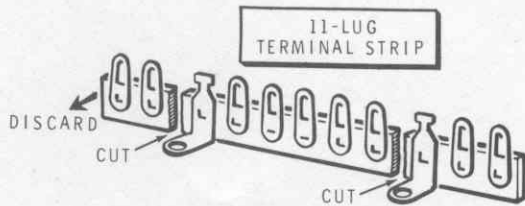

Detail 3-2C

- () Refer to Detail 3-2C and cut the 11-lug terminal strip as shown with diagonal cutters. Discard the 2-lug segment and set the six-lug strip aside temporarily. The two remaining segments will be referred to as the "6-lug terminal strip" and the "3-lug terminal strip."

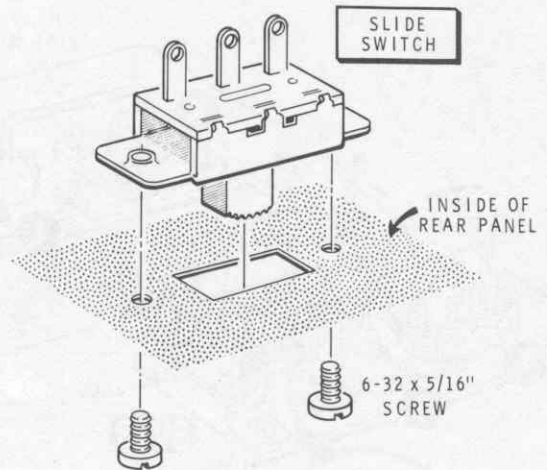

Detail 3-2E

- () Refer to Detail 3-2E and mount the slide switch at SW3 on the rear panel. Position the lugs as shown in the Pictorial. Use two 6-32 x 5/16" screws.

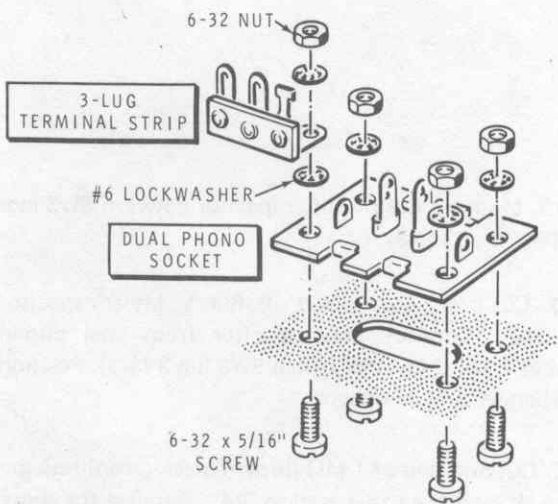

Detail 3-2D

- () Refer to the Pictorial and to Detail 3-2D and mount a dual phono socket at P as shown. Mount the 3-lug terminal strip at T and position it as shown in the Pictorial. Use 6-32 x 5/16" hardware. Be sure to use two lockwashers to mount the terminal strip.

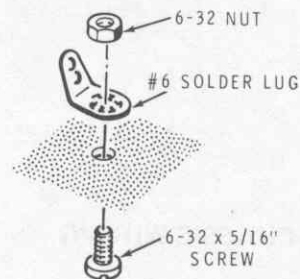

Detail 3-2F

- () Refer to Detail 3-2F and mount a #6 solder lug at Q on the rear panel. Use 6-32 x 5/16" hardware. Position solder lug Q as shown in the Pictorial.

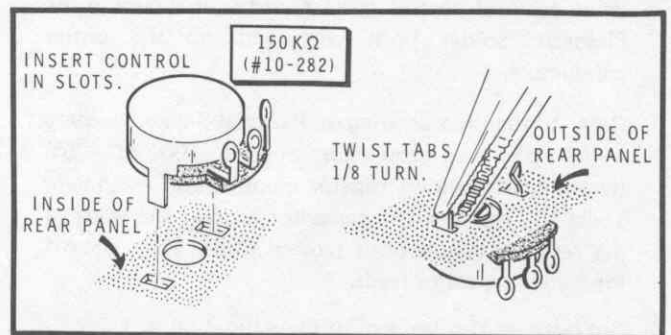

Detail 3-2G

- () Refer to Detail 3-2G and mount the 150 kΩ control (#10-282) at R21 on the rear panel. Position the control lugs as shown in the Pictorial. Then twist the mounting tabs 1/8 turn as shown in the Detail.

- () Mount a dual phono socket at N on the rear panel. Use four sets of 6-32 x 5/16" hardware.

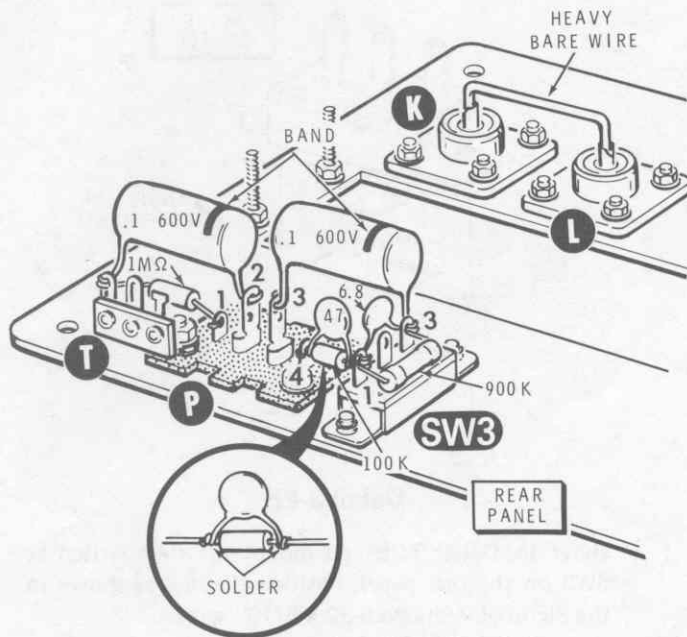

PICTORIAL 3-3

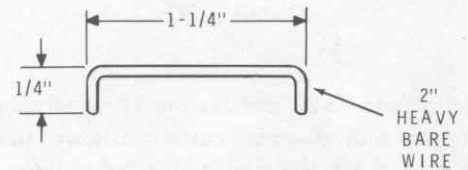

Detail 3-3A

REAR PANEL-CHASSIS WIRING

Refer to Pictorial 3-3 for the following steps.

- () Refer to Detail 3-3A and bend both ends of a 2" heavy bare wire as shown.
- () Mount this heavy bare wire between the center conductors of coaxial jacks K and L as shown in the Pictorial. Solder both wire ends to the center conductors.
- () Refer to the inset drawing on Pictorial 3-3 and prepare a 47 pF disc capacitor and a 100 kΩ, 5% (brown-black-yellow) resistor combination as shown. Twist the leads of the capacitor around the leads of the resistor. Solder both twisted leads. Then cut off the excess capacitor leads.
- () Cut both resistor leads of this combination to 1/2".
- () C14-R4. Mount the 47 pF-100 kΩ resistor combination from dual phono socket P lug 4 (NS) to switch SW3 lug 1 (NS).
- () R3. Mount a 900 kΩ precision resistor between SW3 lugs 1 (NS) and 3 (NS).
- () C13. Mount a 6.8 pF disc capacitor between SW3 lugs 1 (S-3) and 3 (NS).
- () C12. Cut both leads of a .1 μF, 600 V, Mylar capacitor to 3/4". Connect this capacitor from dual phono socket P lug 3 (S-1) to switch SW3 lug 3 (S-3). Position the banded end as shown.
- () R5. Cut one lead of 1 MΩ (brown-black-green) resistor to 1/4" and the other lead to 3/4". Connect the short lead to dual phono socket P lug 1 (S-1) and connect the other lead to terminal strip T lug 1 (NS).
- () C18. Cut the lead on the banded end of a .1 μF, 600 V, Mylar capacitor to 1/4". Cut the other lead to 3/4". Connect the 1/4" lead to dual phono socket P lug 2 (S-1). Connect the other lead to terminal strip T lug 1 (NS).
- () Refer to Pictorial 3-4 and mount the chassis onto the rear panel as shown. Use #6 x 3/8" sheet metal screws at X, Y, and Z.

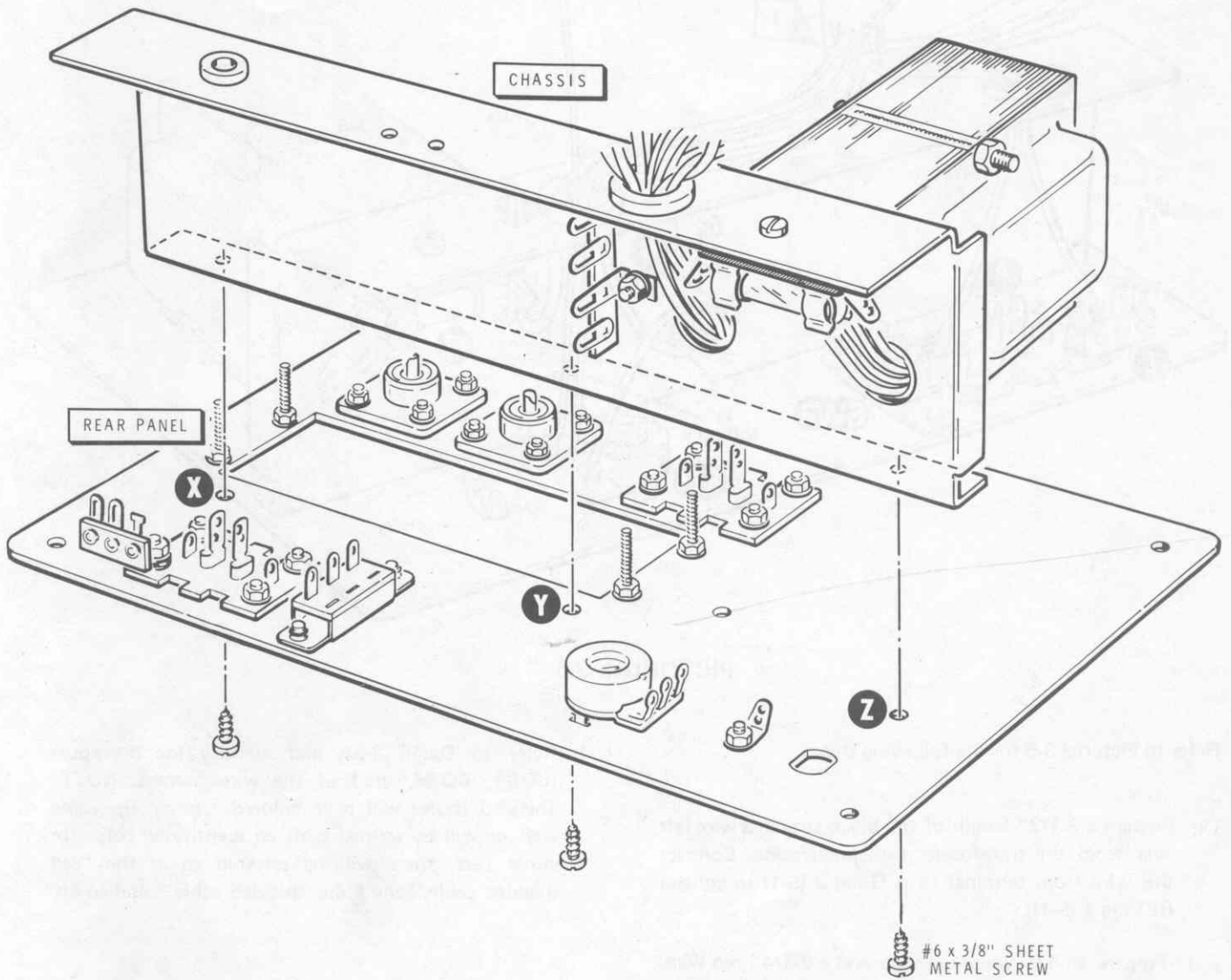

PICTORIAL 3-4

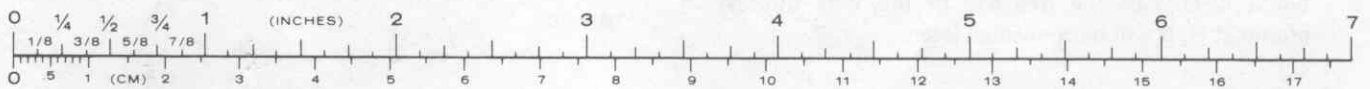

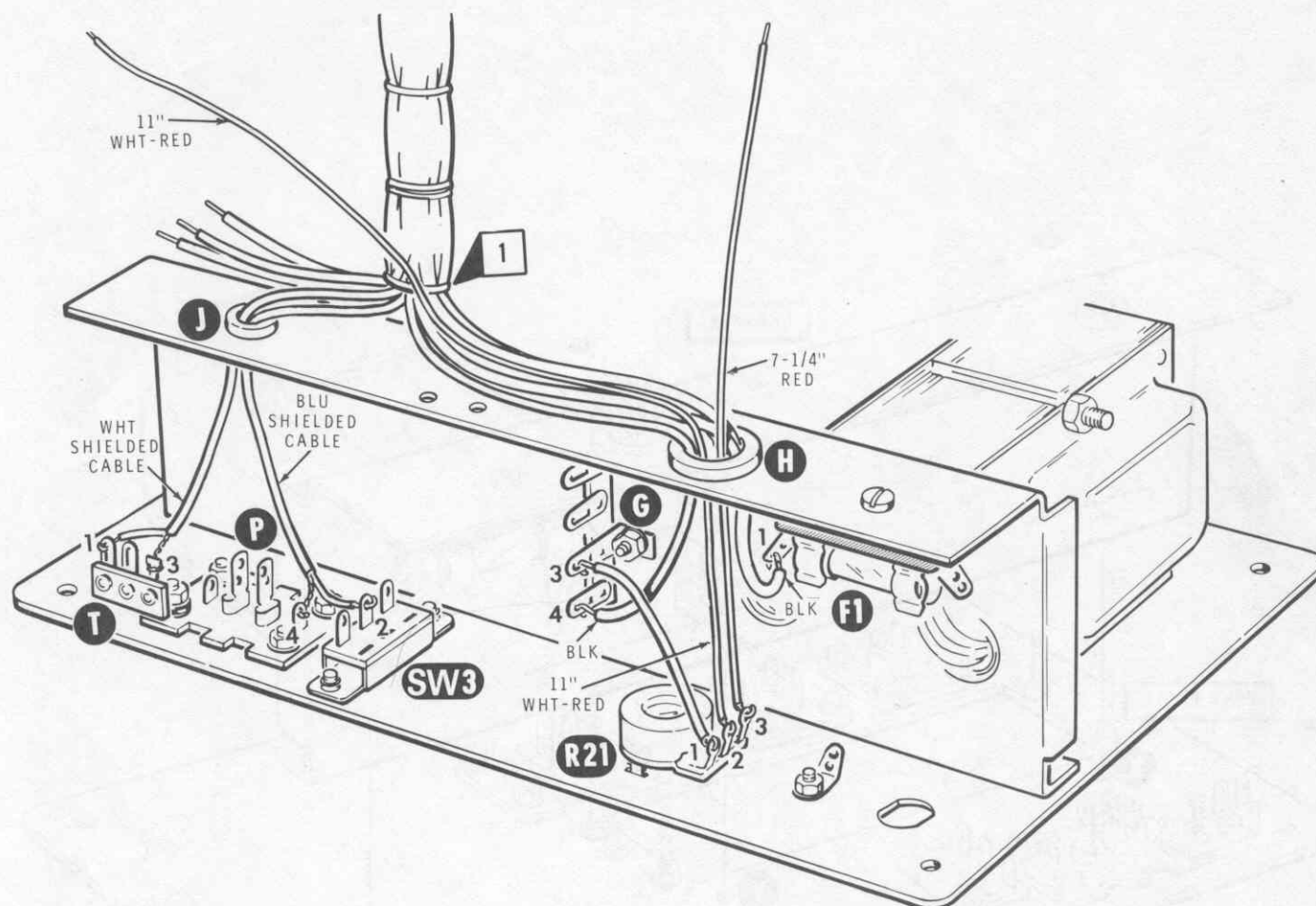

PICTORIAL 3-5

Refer to Pictorial 3-5 for the following steps.

- () Prepare a 2-1/2" length of the black stranded wire left over from the transformer lead preparation. Connect this wire from terminal strip G lug 3 (S-1) to control R21 lug 1 (S-1).
- () Prepare an 11" white-red wire and a 7-1/4" red wire.
- () Connect one end of the 11" white-red wire to control R21 lug 2 (S-1). Pass the free end of this wire through grommet H; it will be connected later.
- () Connect one end of the 7-1/4" red wire to control R21 lug 3 (S-1). Pass the free end of this wire through grommet H; it will be connected later.
- () Refer to Detail 3-5A and identify the breakouts (BO#1, BO#2, etc.) of the wire harness. NOTE: Shielded cables will have colored tags on the cable ends or will be striped with an identifying color. In either case, these will be referred to as the "red shielded cable," the "blue shielded cable," and so on.
- () Pass the free ends of the white and the blue shielded cables coming from BO#1 through grommet J in the chassis as shown.
- () Pass the free ends of both heavy black wires coming from BO#1 through grommet H in the chassis as shown.

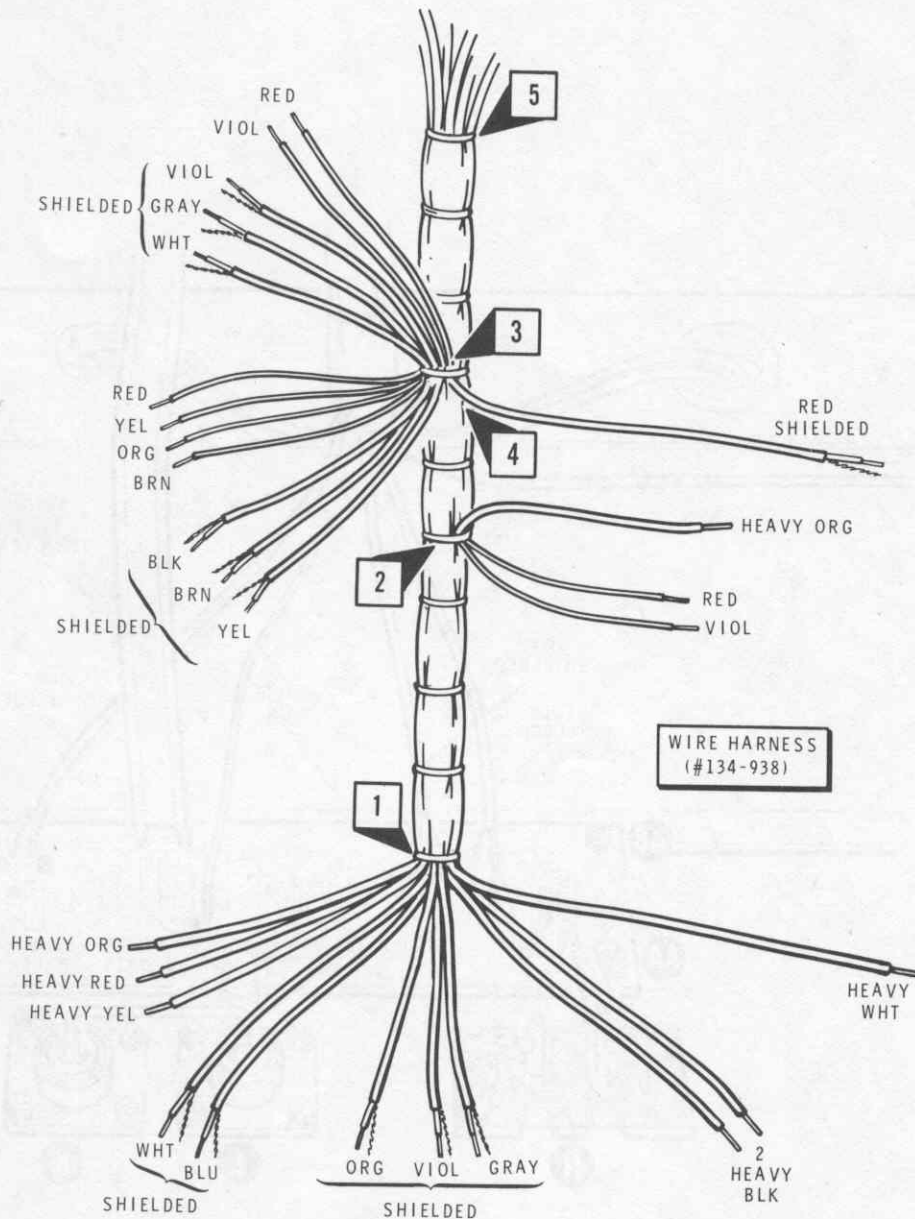

Detail 3-5A

- () Connect the end of either heavy black wire coming from grommet H to terminal strip G lug 4 (S-3). NOTE: The solder instruction is "(S-2)" if your kit is being wired for 240 VAC.
- () Connect the remaining heavy black wire coming from grommet H to fuseholder F1 lug 1 (S-1).
- () Connect the inner lead of the white shielded cable to terminal strip T lug 1 (S-3). Connect the shield lead to terminal strip T lug 3 (S-1).
- () Connect the inner lead of the blue shielded cable to switch SW3 lug 2 (S-1). Connect the shield lead to dual phono socket P lug 4 (S-2).

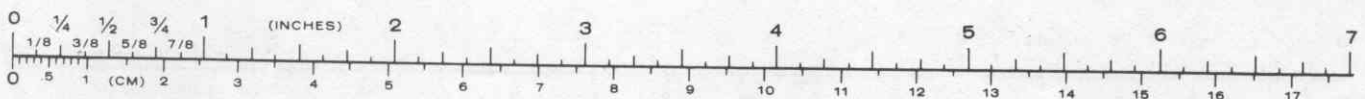

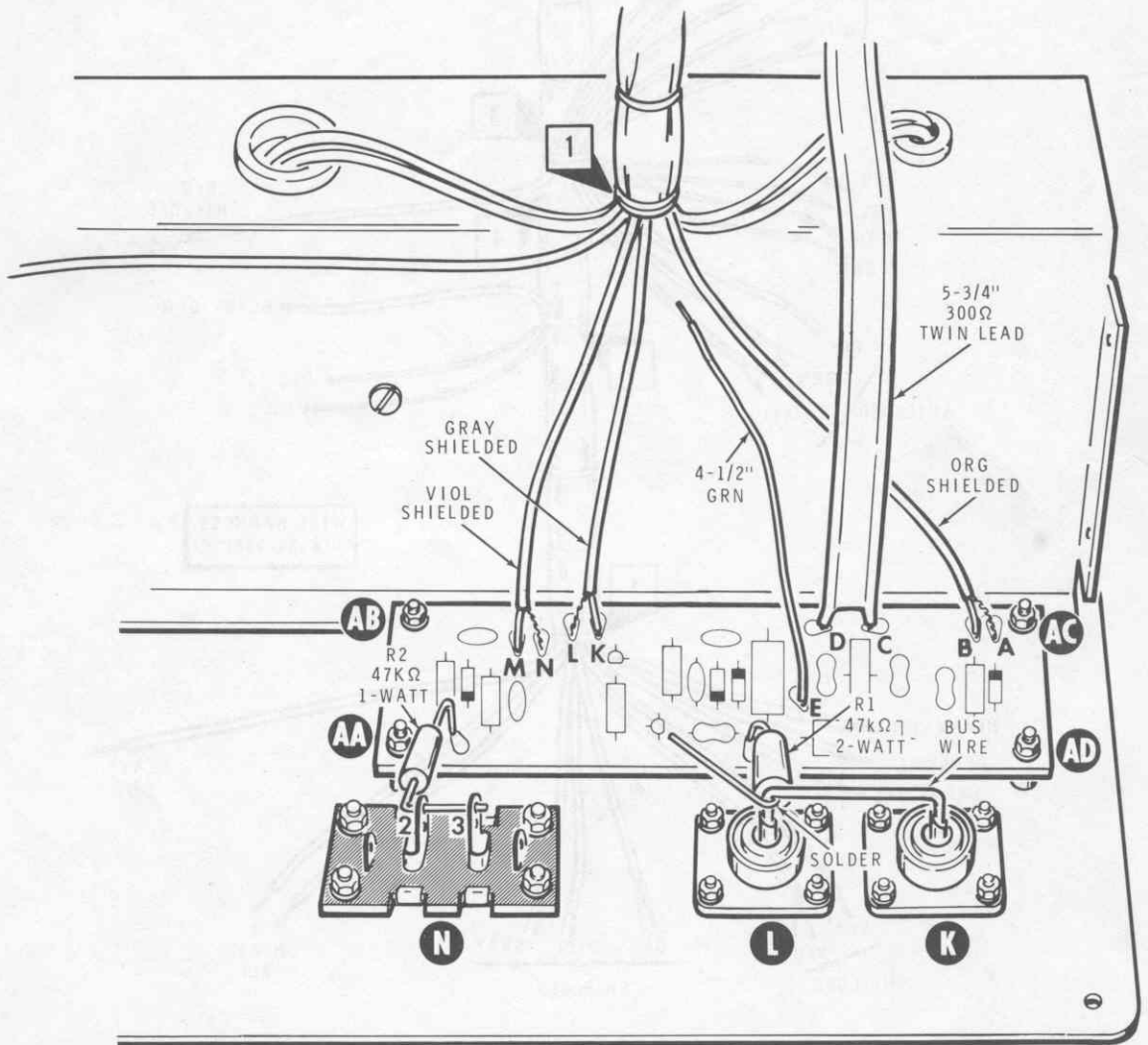

PICTORIAL 3-6

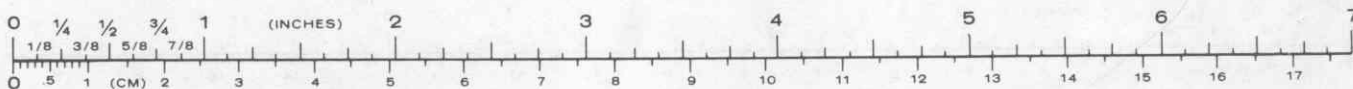

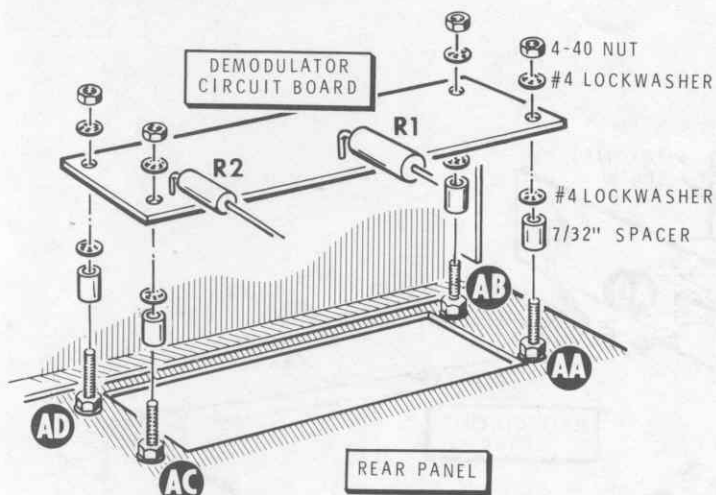

Detail 3-6A

Refer to Pictorial 3-6 for the following steps.

- () Refer to Detail 3-6A and mount the demodulator circuit board onto the rear panel as shown. Pass the free lead of 47 kΩ, 2-watt resistor R1 under the bare wire between coaxial connectors K and L as shown in the Pictorial. Secure the circuit board to the rear panel with 4-40 x 5/8" hardware at AA, AB, AC, and AD.
- () R1. Bend the free lead of resistor R1 over the connector bus wire as shown in the Pictorial (S-1). Do not cut the free end of the resistor lead.
- () R2. Bend the free lead of 47 kΩ 1-watt resistor R2 as shown in the Pictorial. Then pass this lead through lug 2 and into lug 3 of dual phono socket N. Solder the lead to both socket lugs and cut off any excess lead length.

NOTE: Solder each lead to the foil as you connect the shielded cables from BO#1 to the demodulator circuit board foil in the following steps. Then cut off any excess wire lengths.

- () Violet shielded cable: Inner lead to hole M and shield lead to hole N.
- () Gray shielded cable: Inner lead to hole K and shield lead to hole L.
- () Orange shielded cable: Inner lead to hole B and shield lead to hole A.

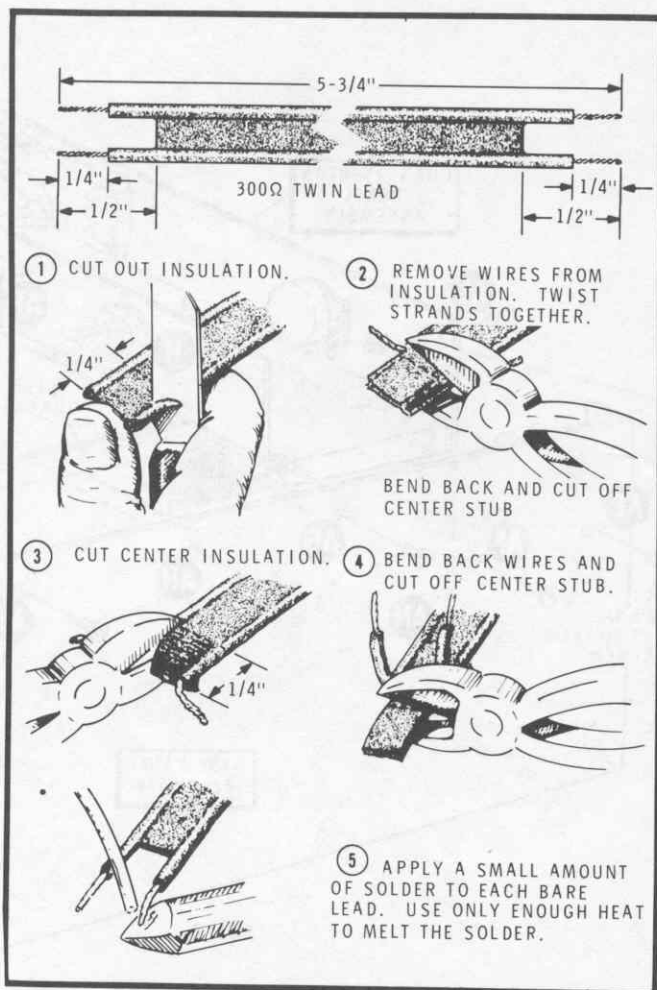

Detail 3-6B

- () Refer to Detail 3-6B and prepare a 5-3/4" length of 300 Ω twin lead as shown.
- () At one end of this twin lead, connect one wire to hole C and the other wire to hole D of the demodulator circuit board. Solder both wires to the foil. The free end of the twin lead will be connected later.
- () Prepare a 4-1/2" green wire.
- () Connect one end of this wire to hole E in the demodulator circuit board (S-1). The free end will be connected later.

NOTE: There are two unused holes on the demodulator circuit board.

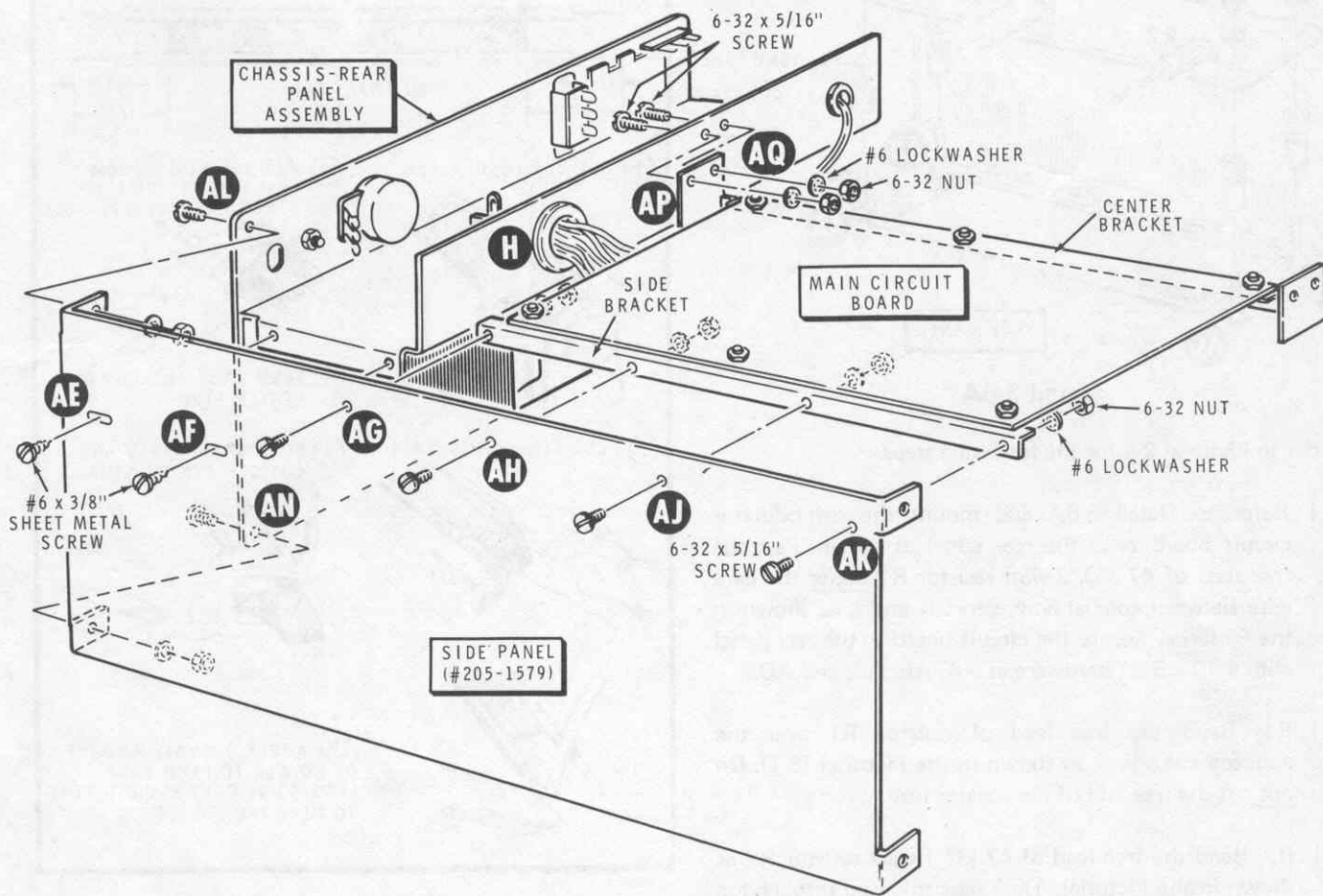

PICTORIAL 4-1

SIDE PANEL MOUNTING

Refer to Pictorial 4-1 for the following steps.

- () Mount a side panel (#205-1579) to the chassis-rear panel assembly at AL and AN with 6-32 x 5/16" hardware.
- () Secure the side panel to the chassis at AE and AF with two #6 x 3/8" sheet metal screws.
- () Secure the main circuit board side bracket to the side panel at AG, AH, AJ, and AK with 6-32 x 5/16" hardware. Position the wires and cable coming from hole H on the component (top) side of the main circuit board as shown.
- () Secure the circuit board center bracket to the chassis at AP and AQ with 6-32 x 5/16" hardware.
- () Tighten the six circuit board mounting screws (see Pictorial 2-8 on Page 27).

MAIN CIRCUIT BOARD WIRING

Refer to Pictorial 5-1 (fold-out from this page) for the following steps.

NOTE: When you connect a wire to the circuit board, as in the following steps, solder it to the foil and cut off any excess wire length.

Connect the wires coming from grommet H to the main circuit board as follows:

- () Heavy yellow wire to hole A (S-1).
- () Heavy blue wire to hole B (S-1).
- () Small red wire to hole K (S-1).

- () Route the heavy green and the heavy green-yellow wires across the rear of the main circuit board. Then connect the green wire to hole E (S-1) and the green-yellow wire to hole F (S-1). Form this twisted pair of wires down onto the side of the circuit board as shown in the Pictorial.

- () Twist the two heavy red wires together. Route them across the rear and down the left side of the board as shown. Connect either red wire to hole G (S-1) and the remaining red wire to hole H (S-1) in the circuit board.

NOTE: The remaining wires coming from grommet H will be connected later.

Connect the wires and cables of the wire harness to the main circuit board as follows:

Wire Color	Breakout No.	Connect to Main Circuit Board Hole
() Heavy white	1	C (S-1)
() Violet	2	L (S-1)
() Red	2	M (S-1)
() Heavy orange	2	N (S-1)
() Red shielded	4	U (inner) lead (S-1) V (shield) (S-1)
() Blue shielded	5	EE (inner) lead (S-1) FF (Shield) (S-1)
() Orange shielded	5	LL (inner) lead (S-1) MM (shield) (S-1)
() Black shielded	5	PP (inner) lead (S-1) QQ (shield) (S-1)

- () Prepare a 3-1/2" length of black wire. Connect one end of this wire to solder lug CA (S-1). The free end will be connected later.

NOTE: The remaining wire harness cables and wires will be connected later.

Set the chassis-circuit board assembly aside temporarily.

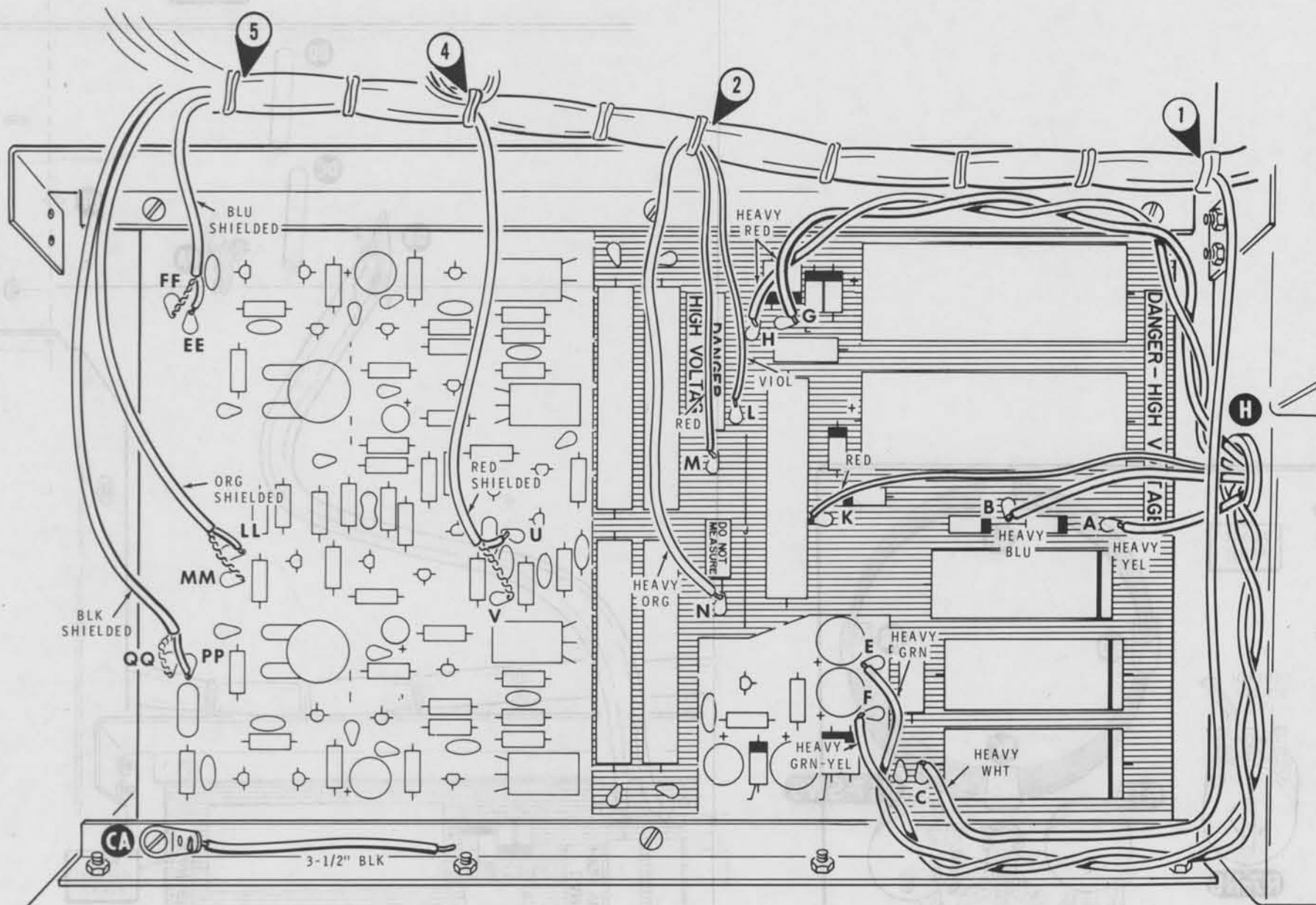

PICTORIAL 5-1



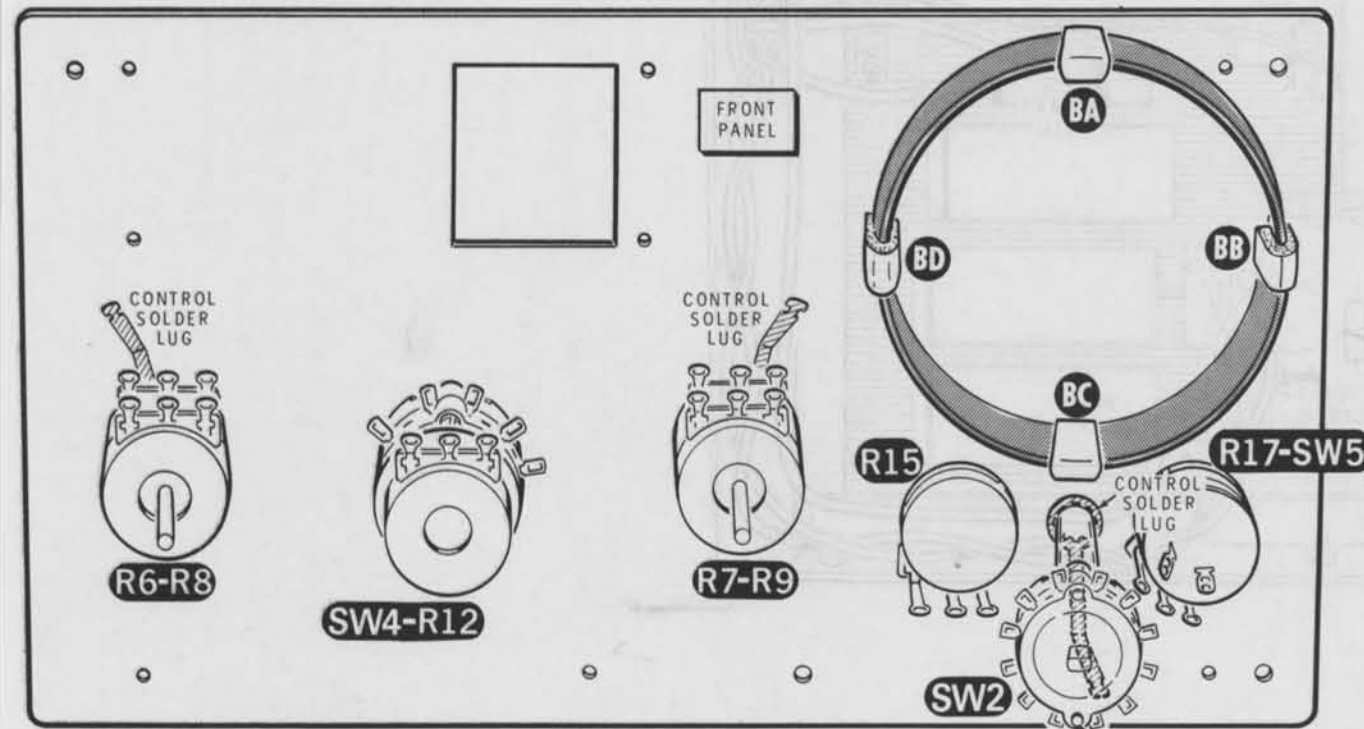

PICTORIAL 7-1

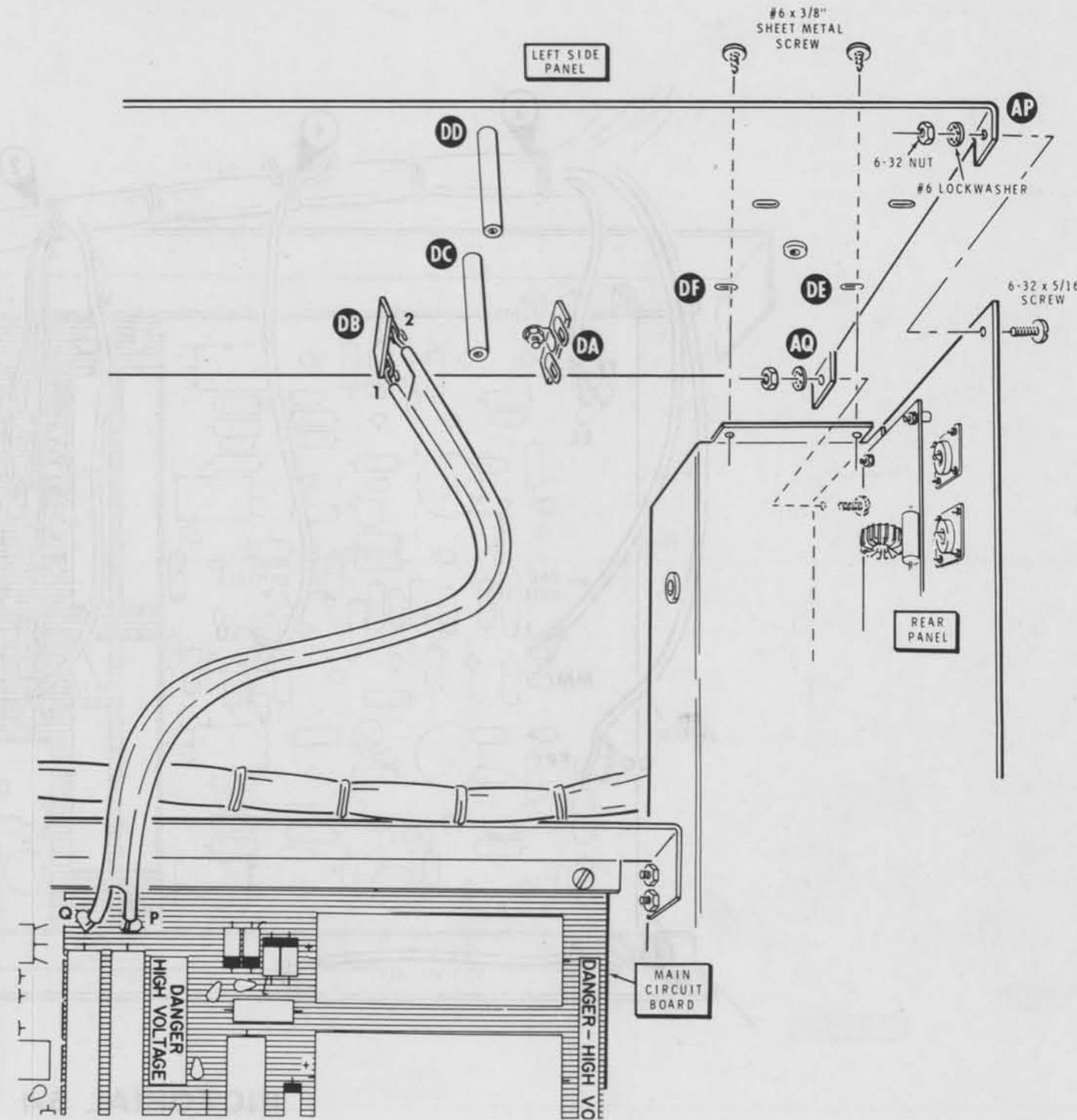

PICTORIAL 6-2

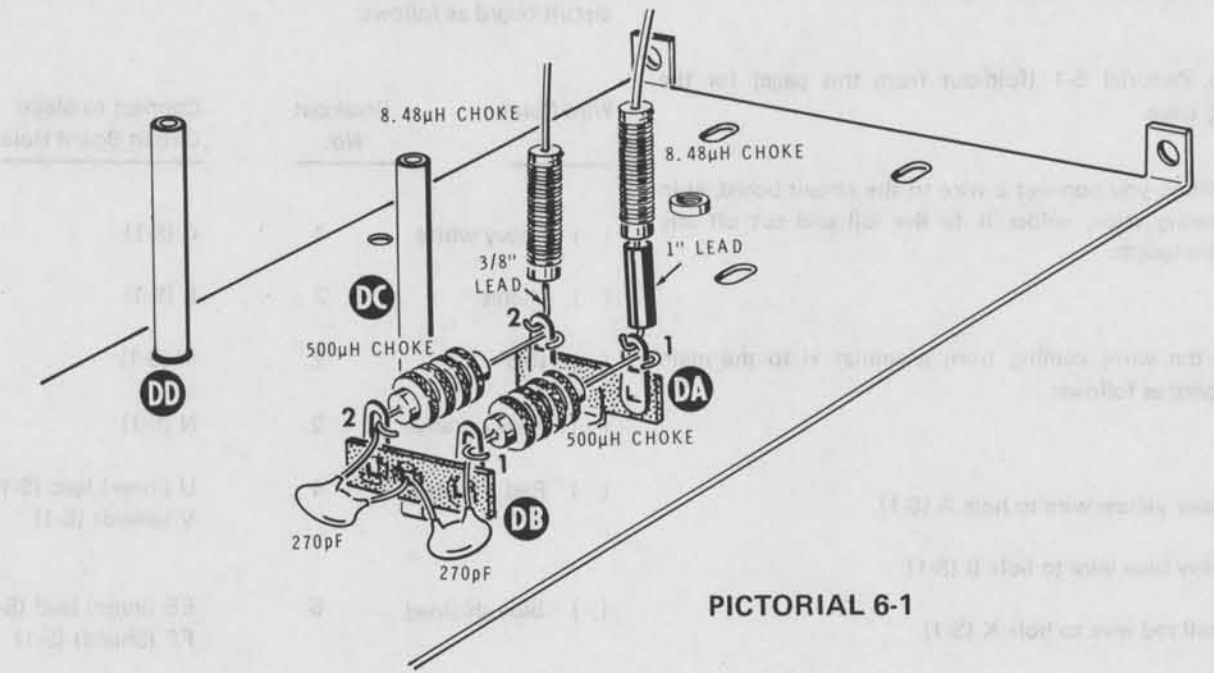

PICTORIAL 6-1

LEFT SIDE PANEL ASSEMBLY

Refer to Pictorial 6-1 for the following steps.

- () Refer to Detail 6-1A and mount a 2-lug terminal strip at DA on the left side panel. Use 6-32 x 5/16" hardware. Position the terminal strip as shown in the Pictorial.
- () In the same manner, mount another 2-lug terminal strip at DB on the side panel. Position the terminal strip as shown in the Pictorial.
- () Refer to Detail 6-1B and mount a 6-32 x 1-3/4" spacer on the left side panel at slotted hole DC. Use 6-32 x 5/16" hardware. Do not tighten the hardware securely at this time.
- () In the same manner, mount another 6-32 x 1-3/4" spacer on the side panel at slotted hole DD.
- () Cut the leads of two 270 pF disc capacitors to 1/2".
- () C19. Connect one lead of a 270 pF disc capacitor to terminal strip DB lug 2 (NS). Position the other lead of this capacitor into the terminal strip center hole (NS).

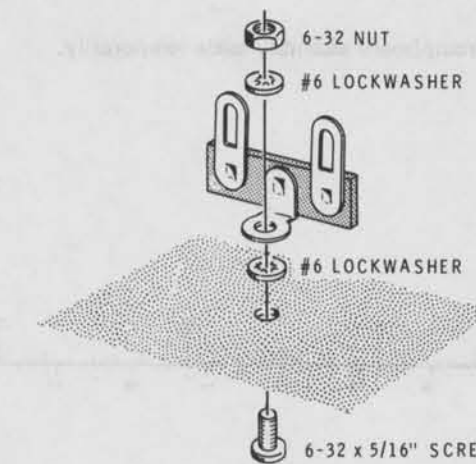

Detail 6-1A

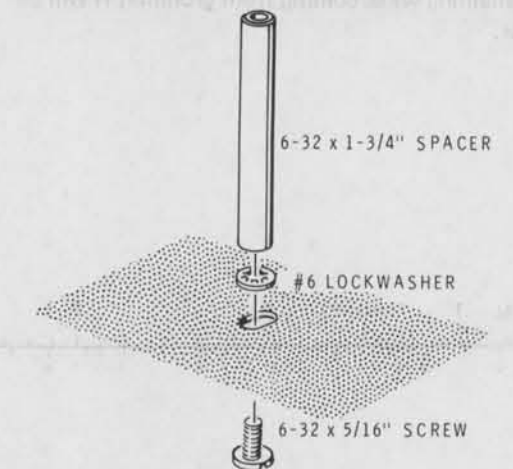

Detail 6-1B

- () C21. Connect one lead of the other 270 pF disc capacitor to terminal strip DB lug 1 (NS). Position the other lead of this capacitor into the terminal strip center hole (S-2).
- () Cut both leads of two 500 μ H chokes (#45-30) to 3/4".
- () RFC1. Connect one lead of a prepared 500 μ H choke to terminal strip DB lug 2 (NS). Connect the other lead to terminal strip DA lug 2 (NS).
- () RFC4. Connect one lead of the other prepared 500 μ H choke to terminal strip DB lug 1 (NS). Connect the other lead to terminal DA lug 1 (NS).
- () Cut both leads of an 8.48 μ H choke (#45-6) to 1".
- () Cut a 3/4" length of sleeving.
- () RFC3. Place the sleeving on the 1" lead of the prepared 8.48 μ H choke. Connect this choke lead to terminal strip DA lug 1 (S-2). The free end will be connected later.
- () Cut one of the leads of the remaining 8.48 μ H choke (#45-6) to 1" and the other lead to 3/8"
- () RFC2. Connect the 3/8" lead of this 8.48 μ H choke to terminal strip DA lug 2 (S-2). The free end will be connected later.

Refer to Pictorial 6-2 for the following steps.

- () Mount the left side panel onto the rear panel with 6-32 x 5/16" hardware at AP and AQ as shown.
- () Secure the left side panel to the chassis at DE and DF with two #6 x 3/8" sheet metal screws.

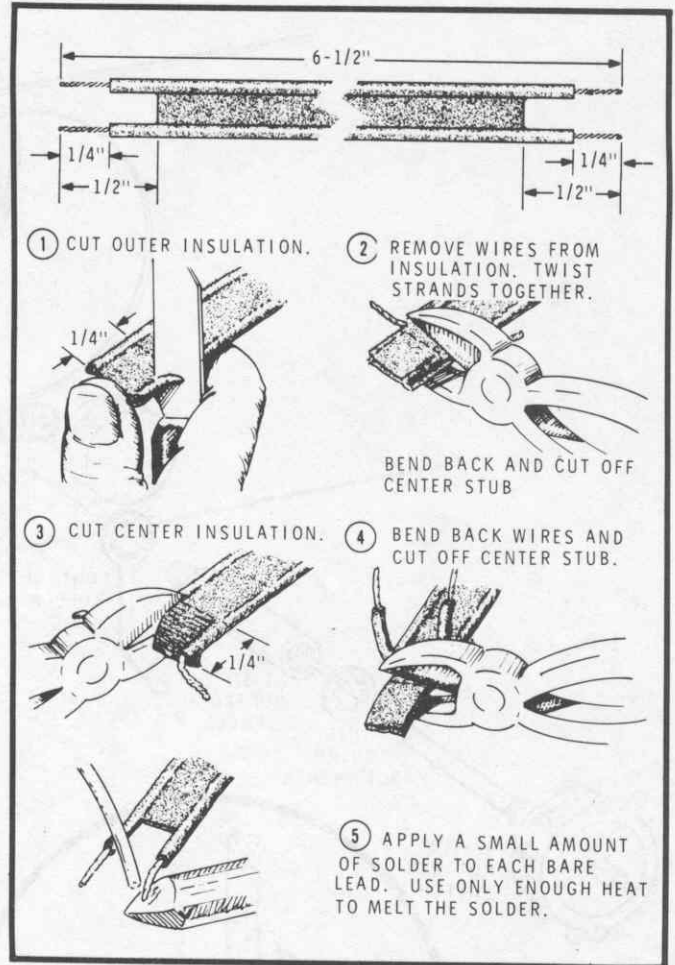

Detail 6-2A

- () Refer to Detail 6-2A and prepare a 6-1/2" length of 300 Ω twin lead. At one end of the twin lead connect one wire to terminal strip DB lug 2 (S-3) and the other wire to lug 1 (S-3).
- () Locate the twin lead wire connected to lug 2 of terminal strip DB. Pass the twin lead over the top of the wire harness and connect this wire to hole P in the main circuit board (S-1). Connect the other twin lead wire to hole Q (S-1).

Set the chassis assembly aside temporarily.

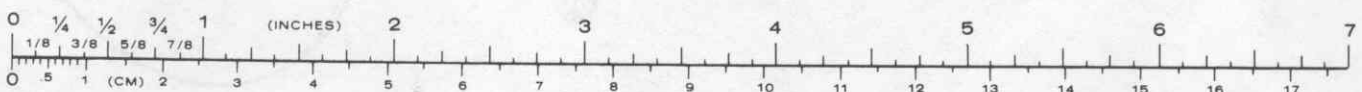

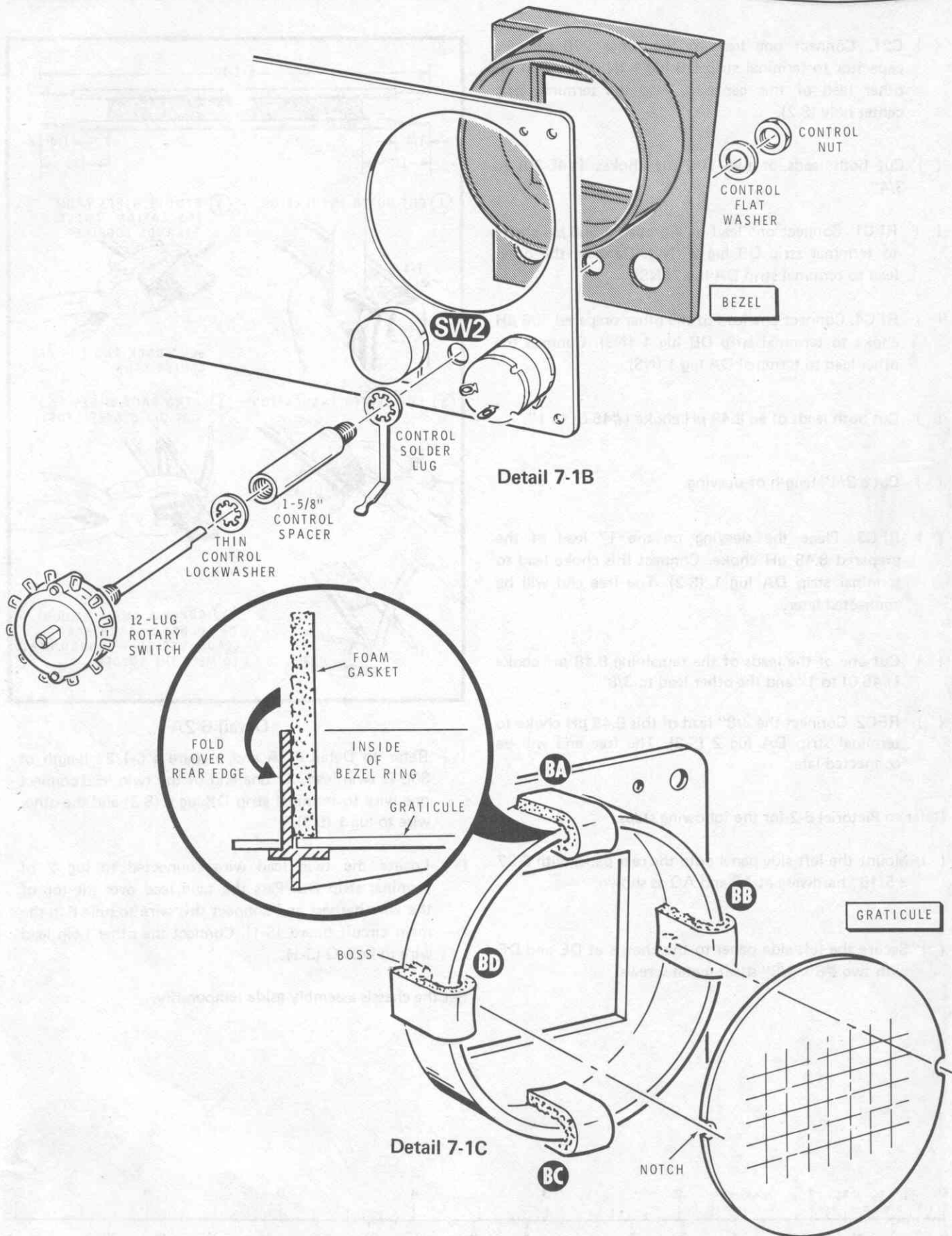

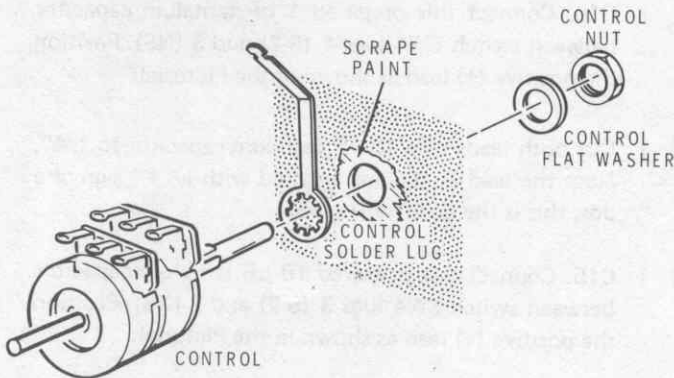

Detail 7-1A

FRONT PANEL PARTS MOUNTING

Refer to Pictorial 7-1 (fold-out from Page 40) for the following steps.

NOTE: Refer to Detail 7-1A for an example as you mount controls and switches on the front panel in the following steps. However, control mounting hardware differs on these components, and will be specifically called out in each of the switch or control steps. As you mount each component, position its lugs (and the control solder lug, if used) as shown in the Pictorial.

- () On the inside of the front panel, scrape any paint from around holes R6-R8, R7-R9, and SW2 to assure a good ground for the solder lugs.
- () R6, R8. Mount a dual control (#12-139) on the front panel at R6-R8 as shown in the Pictorial. Use a control solder lug, a control flat washer, and a control nut.
- () R7, R9. Mount a dual control (#12-139) on the front panel at R7-R9 as shown in the Pictorial. Use a control solder lug, a control flat washer, and a control nut.
- () SW4, R12. Mount the rotary switch with 10 k Ω control (#63-1215) at SW4-R12 on the front panel. Use a thick control lockwasher, a control flat washer, and a control nut.
- () R15. Mount a 1 M Ω control (#10-224) on the front panel at R15 as shown in the Pictorial. Note the downward position of the control lugs. Use a thin control lockwasher and a control nut.
- () R17, SW5. Mount a 250 k Ω control with switch (#19-149) on the front panel at R17-SW5 as shown in the Pictorial. Use a thin control lockwasher and a control nut.

- () Refer to Detail 7-1B and place a thin control lockwasher on the shaft of the 12-lug switch (#63-1214). Place the 1-5/8" control spacer onto the switch shaft as shown and securely tighten it against the lockwasher.

NOTE: 12-lug rotary switch SW2 is symmetrical. Therefore, when you mount it in the following step, it may be positioned in two ways without being incorrect. Be sure the wafer is positioned as shown in the Pictorial.

- () SW2. Position the bezel into the large opening in the front panel and down over the shafts and nuts of controls R15 and R17. Mount the 12-lug rotary switch assembly through hole SW2 in the front panel and through the center control opening in the bezel. Use a control solder lug, a control flat washer, and a control nut.

Refer to Detail 7-1C for the following steps.

NOTE: Do not be concerned if you do not find any paper backing on the graticule in the next step. Some of the graticules and windows in this kit are supplied without paper backing.

- () Remove the paper backing from the graticule. Then position the graticule into the rear of the bezel opening as shown in the Detail. The notches in the sides of the graticule will fit down onto the bosses in the bezel. NOTE: Be sure the grid-screening on the graticule faces outward, toward the front of the panel.
- () Remove the paper backing from one side of a piece of foam gasket material. Refer to the Detail and press the sticky side of the gasket onto the upper inside of the bezel ring at BA so the end of the gasket is against the inside of the graticule. Fold the outer end of the gasket over the rear edge of the bezel and firmly down onto the side of the ring as shown.
- () In the same manner, remove the paper backing from one side of the remaining three pieces of foam gasket material. Press them in place on the inside of the bezel ring at BB, BC, and BD as shown in the Detail. Then fold them over sharply and press each extended end down onto the outside of the bezel ring.

FRONT PANEL PREWIRING

Refer to Pictorial 7-2 for the following steps.

NOTE: When bare wire is called for, as in the following steps, cut the indicated length from any of the remaining short pieces of small hookup wire (except the brown wire). Then remove all the insulation from the wire.

- () Prepare the following lengths of hookup wire:

5-1/2" black	1-1/2" bare
3" black	1-1/2" bare

- () Connect a 5-1/2" black wire from solder lug SL1 (NS) to solder lug SL2 (NS).
- () Connect one end of a 3" black wire to solder lug SL2 (NS). The free end will be connected later.

NOTE: When a wire passes through a connection and then goes to another point, as in the following steps, the solder step at the "through" junction will count as two wires (S-2), one entering and one leaving the connection.

- () Connect one end of a 1-1/2" bare wire to control R8 lug 1 (S-1). Pass the free end of the wire through control R6 lug 1 (S-2) and connect it to solder lug SL1 (NS).
- () Connect one end of a 1-1/2" bare wire to control R9 lug 1 (S-1). Pass the free end of this wire through control R7 lug 3 (S-2) and connect it to solder lug SL2 (NS).
- () Cut both leads of a 470 Ω (yellow-violet-brown) 1/2-watt resistor to 3/8".
- () R11. Connect the prepared 470 Ω resistor from control R12 lug 3 (S-1) to switch SW4 lug 2 (NS).
- () Cut both leads of a .1 μ F Mylar capacitor to 1/4".
- () C17. Connect the prepared .1 μ F capacitor between switch SW4 lugs 5 (S-1) and 4 (NS).
- () Cut both leads of a 1 μ F tantalum capacitor to 1/2".
NOTE: The positive (+) end of this capacitor may be designated with a color or a "+" sign.

- () C16. Connect this prepared 1 μ F tantalum capacitor between switch SW4 lugs 4 (S-2) and 3 (NS). Position the positive (+) lead as shown in the Pictorial.
- () Cut both leads of a 10 μ F tantalum capacitor to 1/4". Note the lead at the end marked with a "+" sign or a dot; this is the positive (+) lead.
- () C15. Connect this prepared 10 μ F tantalum capacitor between switch SW4 lugs 3 (S-2) and 2 (NS). Position the positive (+) lead as shown in the Pictorial.
- () Cut both leads of a 2.2 M Ω (red-red-green), 1-watt resistor to 3/4".
- () R14. Connect this prepared 2.2 M Ω resistor from control R15 lug 1 (S-1) to solder lug SL3 (S-1).
- () Cut two 1/2" lengths of sleeving.
- () Place a 1/2" piece of sleeving on each lead of a 470 k Ω (yellow-violet-yellow), 1-watt resistor.
- () R16. Connect the prepared 470 k Ω resistor from control R15 lug 3 (S-1) to control R17 lug 3 (S-1).

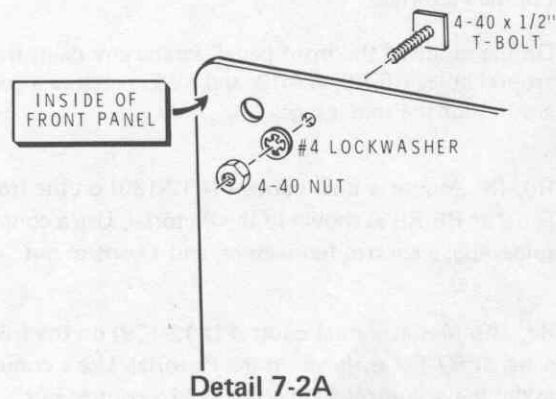

Detail 7-2A

NOTE: In the following steps, you will be instructed to mount T-bolts on the front panel. To do this, install the T-bolt through the panel and place one or more lockwashers, as directed, on the bolt. Then just start the nuts onto the bolt threads. These nuts will be tightened in later steps.

- () Refer to Detail 7-2A and loosely mount a 4-40 x 1/2" T-bolt on the front panel at hole BJ.
- () In the same manner, loosely mount 4-40 x 1/2" T-bolts at holes BK, BL, BN, BP, and BQ.

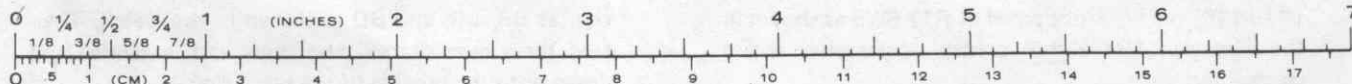

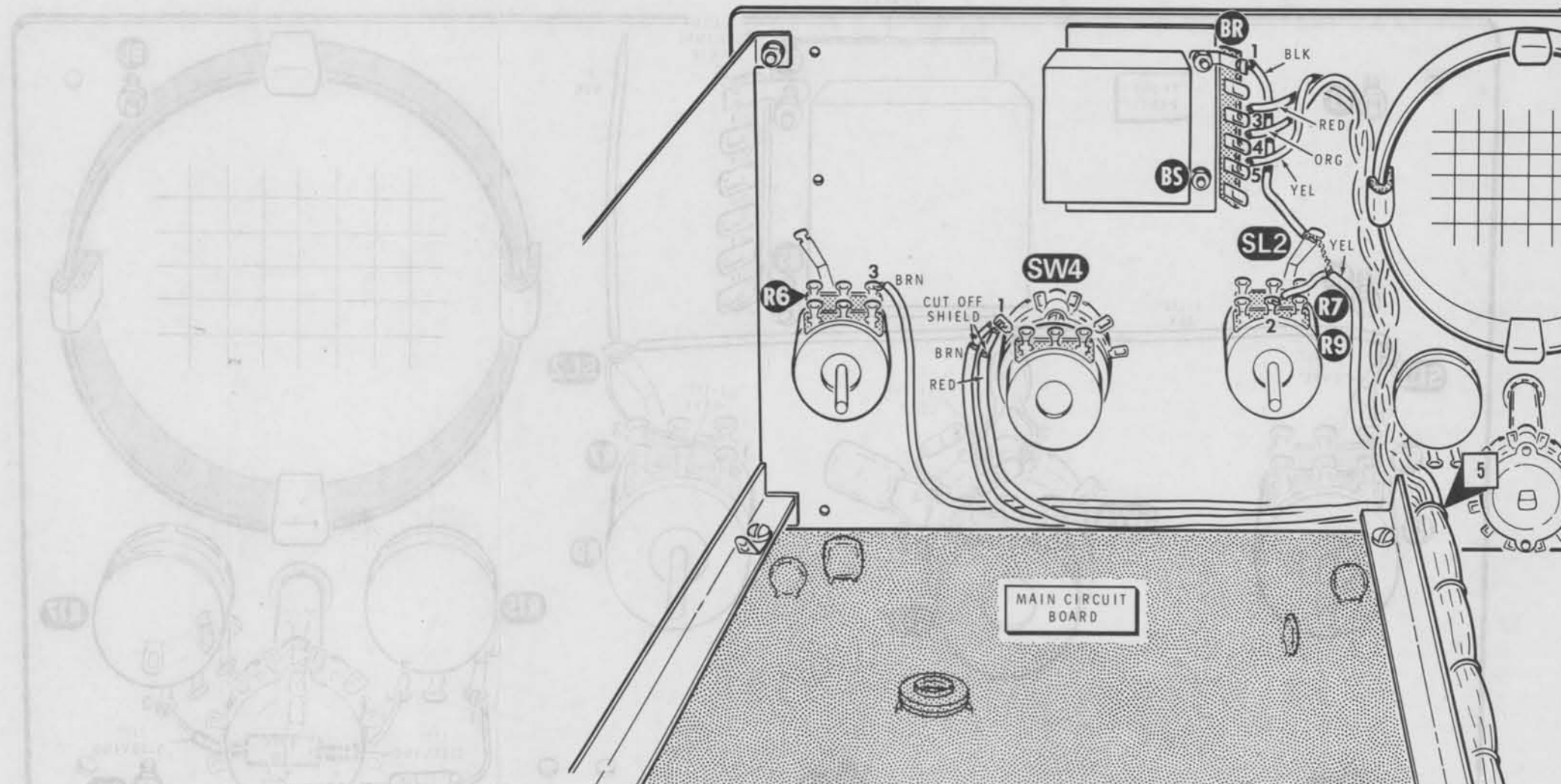

PICTORIAL 8-1

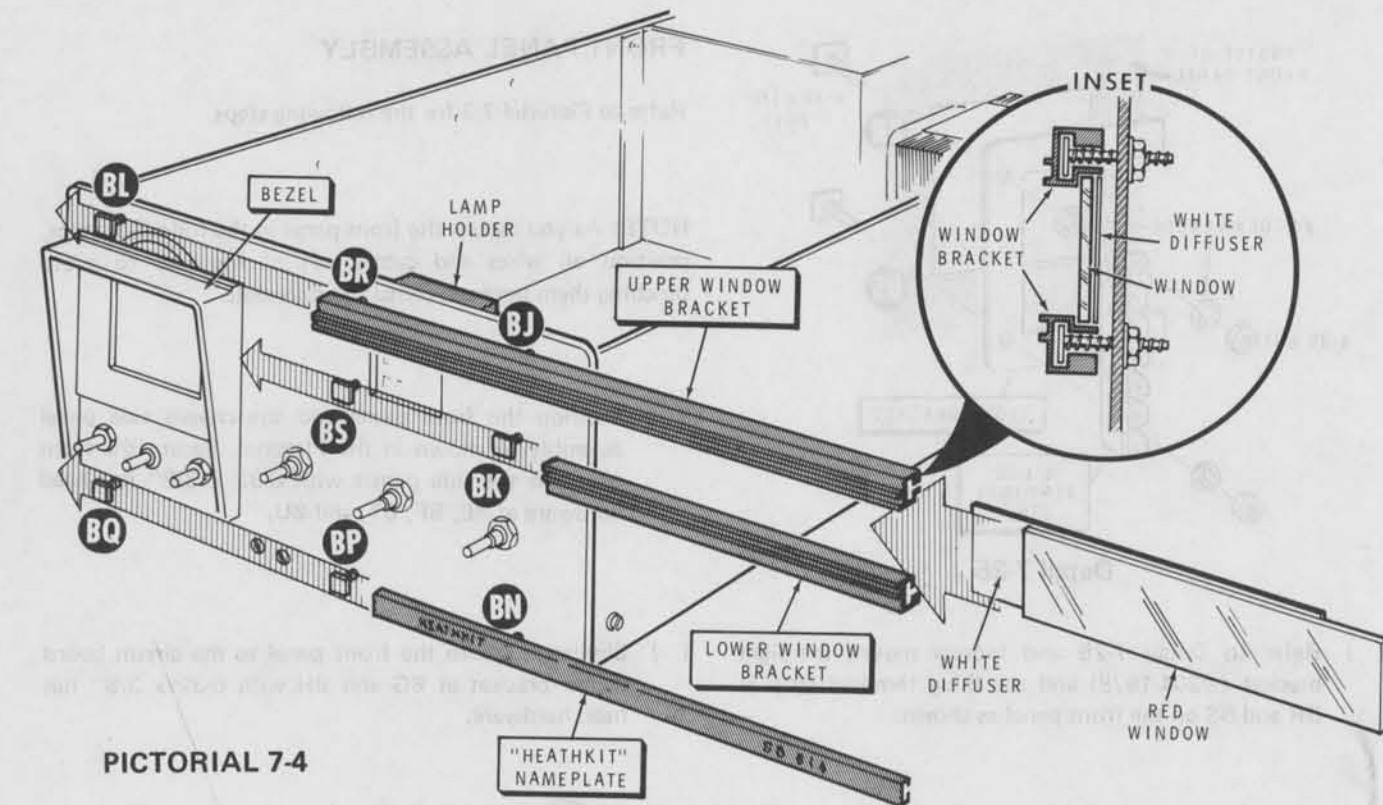

PICTORIAL 7-4

Refer to Pictorial 7-4 for the following steps.

- () Position the "Heathkit" nameplate right-side-up and slide it onto the heads of the T-bolts at BN, BP, and BQ at the bottom of the front panel as shown. Center the nameplate on the front panel; then tighten the three T-bolt nuts on the rear of the panel.

NOTE: In the following steps it is important that the window brackets be installed properly or the window will not fit.

- () Refer to the inset drawing on Pictorial 7-4 for an end view of the window brackets. Then slide the lower window bracket onto the T-bolt heads. Position this bracket all the way to the left until it touches the bezel.
- () Similarly, slide the upper window bracket onto the heads of the T-bolts near the top of the panel. Center the bracket across the panel.
- () Slide the white diffuser into place between the two brackets.
- () Carefully remove the paper backing or thin film from the red window.

- () Hold the red window to the light to be sure it is right side up. Then, slide the red window in place on top of the white diffuser, between the upper and lower window brackets as shown.
- () Refer to Detail 7-4A. Then, on the inside of the front panel, lift the open ends of the light bracket and place the lamp holder under the bracket onto the rear surface of the white diffuser.
- () Tighten the T-bolt nuts at BJ, BK, BL, and BS. Position the 6-lug terminal strip so it is at least 1/8" away from the lower stud at BS; then tighten the nut at BR.

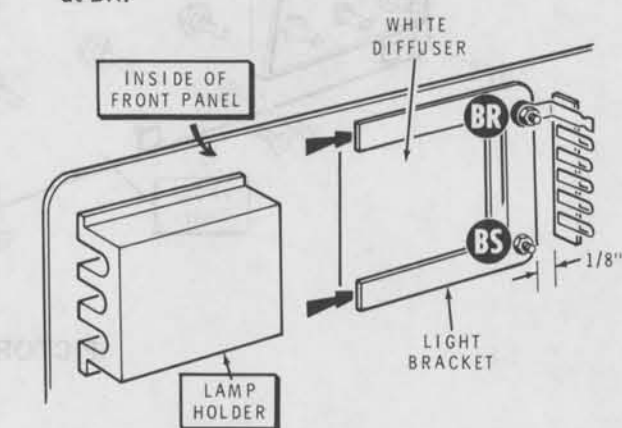

Detail 7-4A

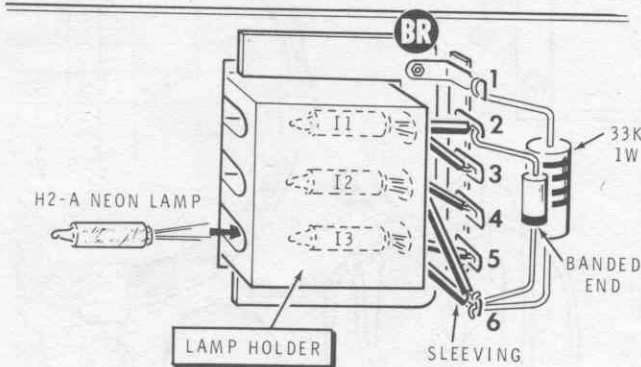

Detail 8-1A

FRONT PANEL WIRING

Refer to Pictorial 8-1 (fold-out from Page 46) for the following steps.

- () Connect the black wire coming from solder lug SL2 to lug 1 of terminal strip BR (NS).
- () Cut both leads of a 33 kΩ (orange-orange-orange), 1-watt resistor to 1".

Refer to Detail 8-1A for the following steps.

- () R13. Mount the prepared 33 kΩ resistor between terminal strip BR lugs 1 (S-2) and 6 (NS).
- () Cut the leads of a 1N4002 diode (#57-65) to 3/4". NOTE: When you install this diode in the following step, be sure to position the banded end as shown in the Detail.
- () D1. Mount the prepared 1N4002 diode between terminal strip BR lugs 2 (NS) and 6 (NS).

NOTE: To install the indicator lamps in the following steps, slide each lamp lead first into the lamp holder from the side opposite the terminal strip. Then place sleeving on each lead and connect the leads to the indicated terminal strip lugs. Solder the lamp leads as instructed in the steps.

- () Cut six 1/2" lengths of sleeving.
- () I3. Place a 1/2" length of sleeving on each lead of an HA-2 neon lamp. Slide the lamp, leads first, into the bottom slot in the lamp holder. Connect one lamp lead to terminal strip BR lug 6 (NS) and the other lead to lug 5 (NS).

- () I2. In the same manner, place 1/2" of sleeving on both leads of another HA-2 neon lamp. Slide this lamp, leads first, into the center slot in the lamp holder. Connect one lead to terminal strip BR lug 4 (NS) and the other lead to lug 6 (S-4). NOTE: Be sure all the leads on lug 6 of the terminal strip are well soldered; some leads may be concealed by others.

- () I1. Place 1/2" of sleeving on the leads of the remaining HA-2 neon lamp. Slide the lamp into the top slot of the lamp holder. Connect one lamp lead to terminal strip BR lug 3 (NS) and the other lead to lug 2 (S-2).

Refer to Pictorial 8-1 for the following steps.

- () Route the small brown wire coming from BO#5 across the front of the main circuit board and connect it to control R6 lug 3 (NS).
- () Locate the small red, orange, and yellow wires coming from BO#5 on the wire harness. Tightly twist the three wires together.
- () Route the twisted red, orange, and yellow wires between the bezel and controls R7-R9 as shown, and across to terminal strip BR. Connect the yellow wire to terminal strip BR lug 5 (S-2), the orange wire to lug 4 (S-2), and the red wire to lug 3 (S-2).
- () Carefully inspect all connections on terminal strip BR. Make sure that every wire and lead is firmly soldered, that all excess wire and lead lengths have been cut off, and that all leads connected to lug 6 of the terminal strip are completely clear of the adjacent T-bolt stud at BS.
- () Locate the red and the brown-shielded cables coming from BO#5. Cut the shield (outer) leads from both cables. Route the two cables across the front edge of the main circuit board as shown in the Pictorial. Connect the inner leads of both shielded cables to switch SW4 lug 1 (S-2).
- () Connect the inner lead of the yellow shielded cable coming from BO#5 to control R9 lug 2 (NS). Connect the shield lead to solder lug SL2 (S-4).



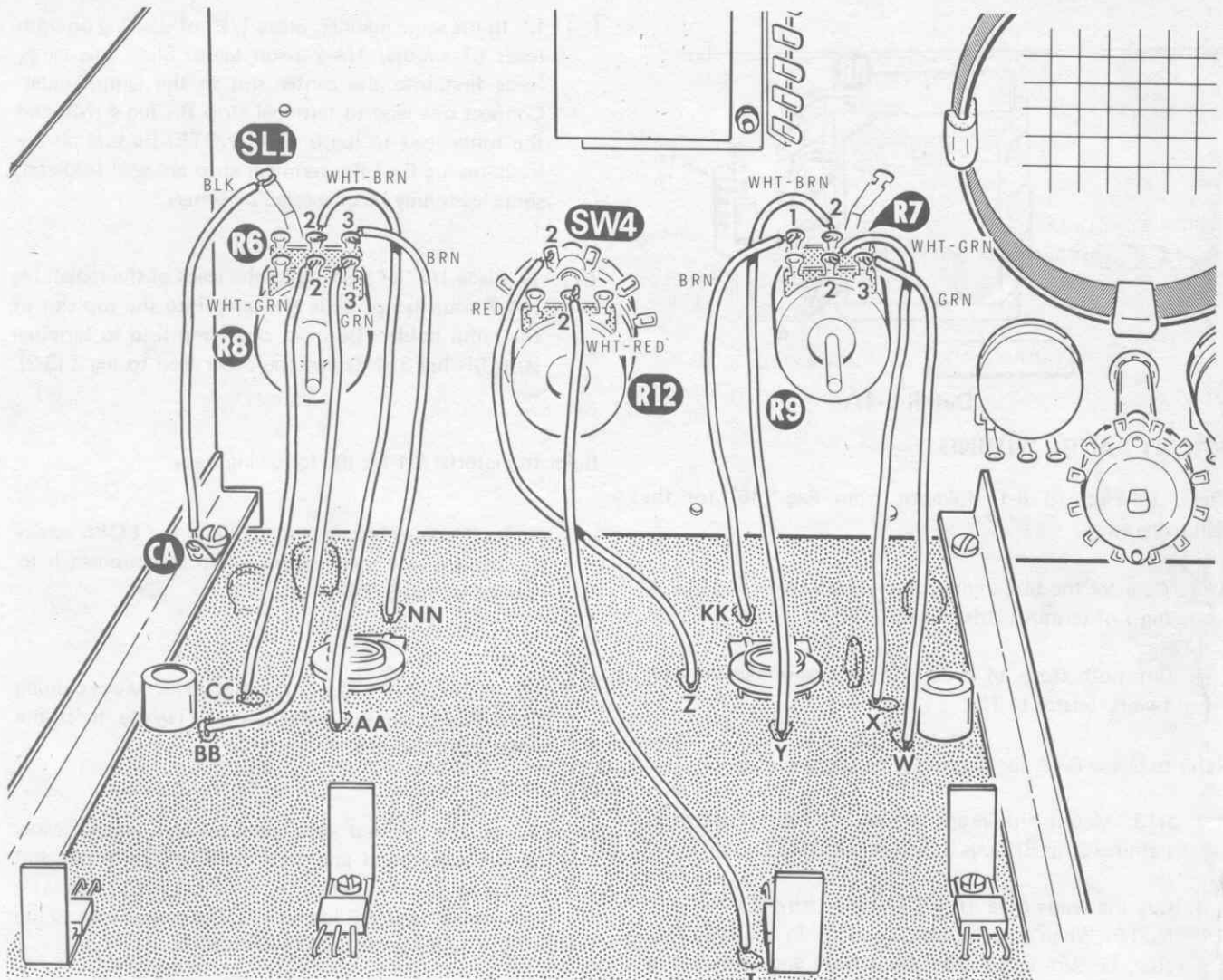

PICTORIAL 8-2

Refer to Pictorial 8-2 for the following steps.

NOTE: Connect the wires coming from the main circuit board to front panel switches and controls in the following steps. As you solder each connection, cut off any excess wire lengths.

- () Red wire coming from Z to switch SW4 lug 2 (S-3).
- () White-red wire coming from T to control R12 lug 2 (S-1).
- () Brown wire coming from NN to control R6 lug 3 (S-2).
- () Black wire coming from solder lug CA to solder lug SL1 (S-3).
- () White-green wire coming from CC to control R8 lug 2 (S-1).
- () Green wire coming from BB to control R8 lug 3 (S-1).
- () White-brown wire coming from AA to control R6 lug 2 (S-1).
- () Brown wire coming from KK to control R7 lug 1 (S-1).
- () White-brown wire coming from Y to control R7 lug 2 (S-1).
- () White-green wire coming from X to control R9 lug 2 (S-2).
- () Green wire coming from W to control R9 lug 3 (S-1).

NOTE: There are five unused holes on the main circuit board.

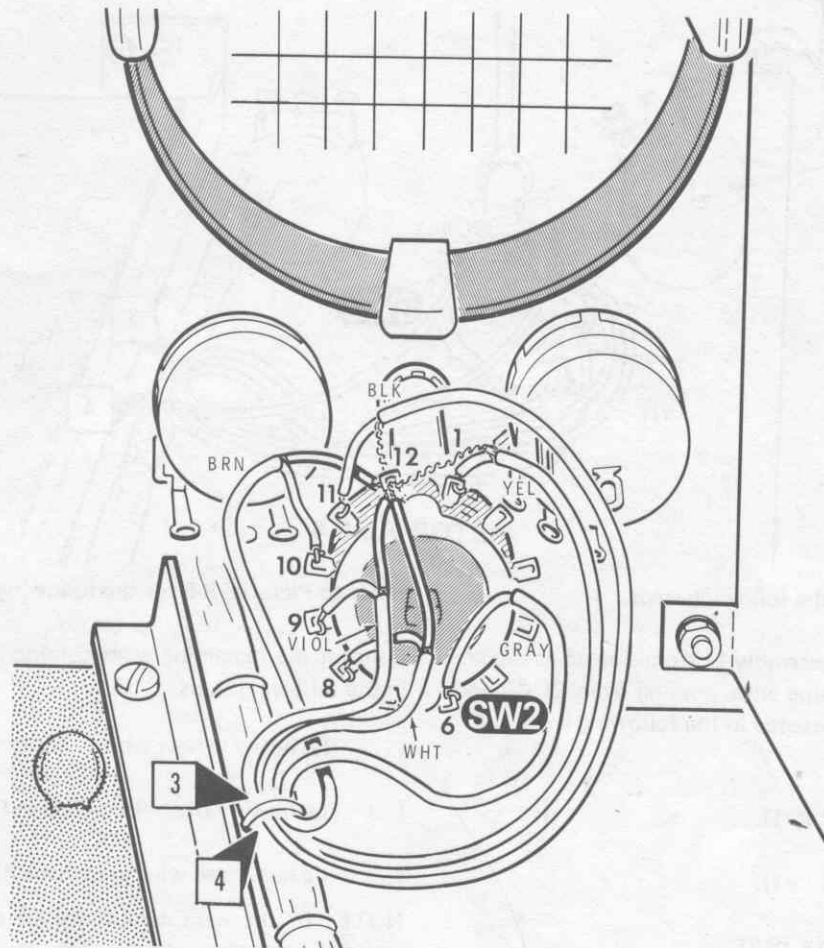

PICTORIAL 8-3

Refer to Pictorial 8-3 for the following steps.

NOTE: Connect the six shielded cables coming from BO#3 and BO#4 to switch SW2 as directed in the following steps.

- () Locate the gray shielded cable. Cut the shield lead from the free end of this cable.
- () Connect the inner lead of the gray shielded cable to switch SW2 lug 6 (S-1).
- () Cut three 3/4" lengths of sleeving.
- () Connect the inner lead of the white shielded cable to switch SW2 lug 8 (S-1). Place a 3/4" piece of sleeving on the shield lead; then connect the lead to lug 12 (NS).
- () Connect the inner lead of the violet shielded cable to switch SW2 lug 9 (S-1). Place a 3/4" piece of sleeving on the shield lead; then connect the lead to lug 12 (NS).
- () Connect the inner lead of the brown shielded cable to switch SW2 lug 10 (S-1). Place a 3/4" piece of sleeving on the shield lead; then connect the lead to lug 12 (NS).
- () Connect the inner lead of the black shielded cable to switch SW2 lug 11 (S-1). Connect the shield lead to lug 12 (NS).
- () Connect the inner lead of the yellow shielded cable to switch SW2 lug 1 (S-1). Connect the shield lead to lug 12 (S-5). NOTE: When you perform this final solder step (S-5), apply enough solder and heat to assure a good connection for all five shield leads.

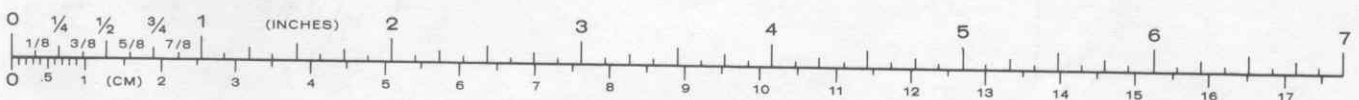

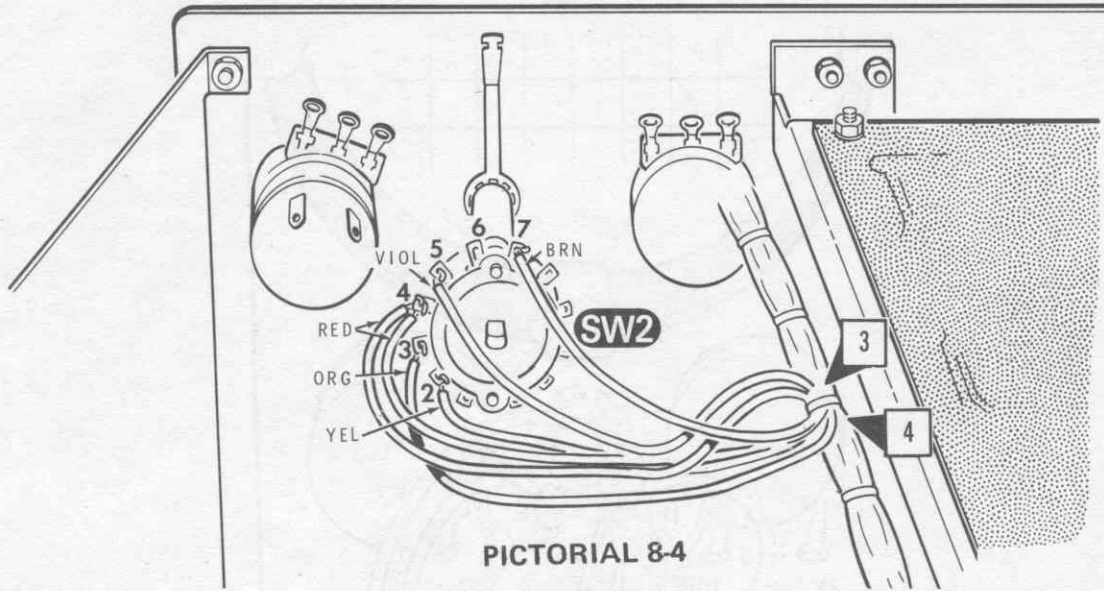

PICTORIAL 8-4

Refer to Pictorial 8-4 for the following steps.

NOTE: Turn the chassis assembly bottom-side-up as shown. Then connect the remaining wires coming from BO#3 and BO#4 to switch SW2 as directed in the following steps.

- () Yellow wire to lug 2 (S-1).
- () Orange wire to lug 3 (S-1).
- () Two red wires to lug 4 (S-2).
- () Violet wire to lug 5 (S-1).
- () Brown wire to lug 7 (S-1).

Refer to Pictorial 8-5 for the following steps.

Connect the remaining wires coming from BO#5 as directed in the following steps.

- () The heavy yellow wire to control R15 lug 2 (S-1).
 - () The heavy white wire to control R17 lug 1 (S-1).
 - () The heavy red wire to control R17 lug 2 (S-1).
- NOTE: In the next two steps, be sure the wire ends are wrapped securely around the indicated lugs to make mechanically secure connections.
- () Either heavy black wire to switch SW5 lug 1 (S-1).
 - () The remaining black wire to SW5 lug 2 (S-1).

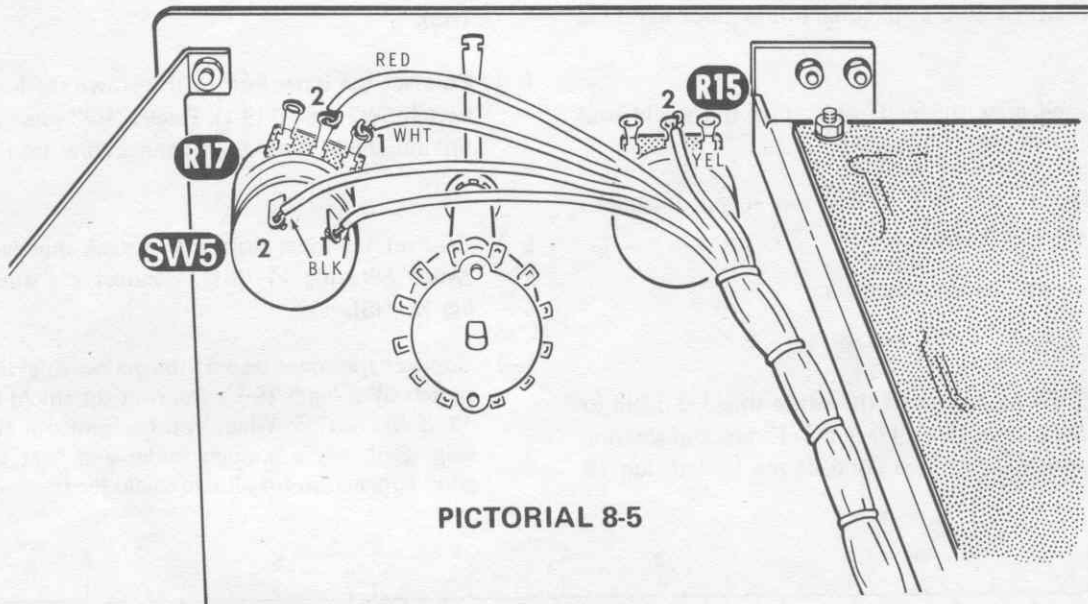

PICTORIAL 8-5

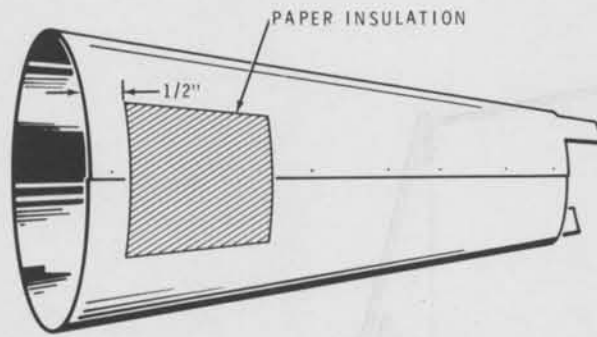

Detail 9-1A

CRT INSTALLATION

Refer to Pictorial 9-1 (fold-out from this page) for the following steps.

- () Refer to Detail 9-1A and remove the paper backing from the small rectangle of paper insulator. Press this insulator 1/2" in from edge of the wide opening and squarely across the seam of the CRT shield as shown.

WARNING: Handle the CRT very carefully. Because of its high vacuum, do not strike, scratch, or subject the CRT to more than moderate pressure at any time. A fracture of the glass could result in an implosion of considerable violence capable of causing personal injury.

- () Carefully unpack the CRT.
- () Place the CRT face down on a cloth pad and slide the CRT shield in place around the CRT.
- () Align the CRT socket keyway with the CRT key and carefully but firmly press the socket in place on the base of the CRT.
- () Cut both leads of a 1 MΩ, 1/2-watt (brown-black-green) resistor to 1/2".

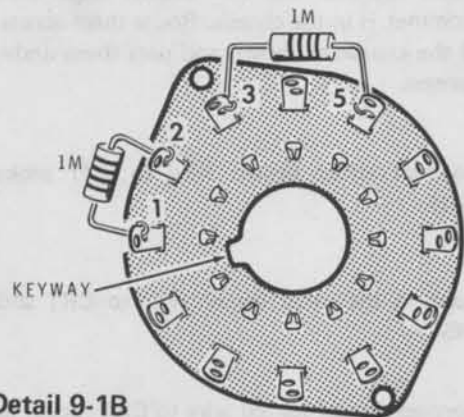

Detail 9-1B

Refer to Detail 9-1B to identify the CRT socket lug numbers and for the next two steps.

- () R19. Mount the prepared 1 MΩ resistor between CRT socket lugs 1 (NS) and 2 (NS).
- () Cut the leads of another 1 MΩ, 1/2-watt (brown-black-green) resistor to 3/4".
- () R18. Mount the prepared resistor between CRT socket lugs 3 (S-1) and 5 (NS).
- () Refer to the Pictorial and press the CRT into its opening in the bezel. Position the socket locating key at the 8 o'clock position as viewed from the rear.
- () Slide the CRT shield forward over the outer portion of the bezel; then center the shield seam and the paper insulator directly above switch SW2.
- () Cut the cushion strip into two equal lengths.

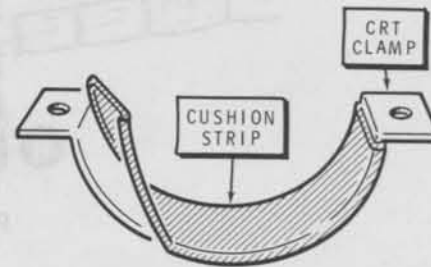

Detail 9-1C

- () Refer to Detail 9-1C and place a length of cushion strip onto each of the CRT clamps as shown.
- () Install the two CRT clamps on the spacers at DC and DD and around the neck of the CRT. Loosely secure the clamps with 6-32 x 5/16" hardware as shown.
- () Push the CRT forward as far as it will go to be sure the face of the CRT touches the back side of the green graticule
- () Position the spacers at DC and DD so the CRT clamps do not touch the glass portion of the tube. Tighten the side panel hardware on spacers DD and DC.
- () Remove the paper backing from the "Danger" label. Press this label in place on the top of the CRT shield as shown in the Pictorial.

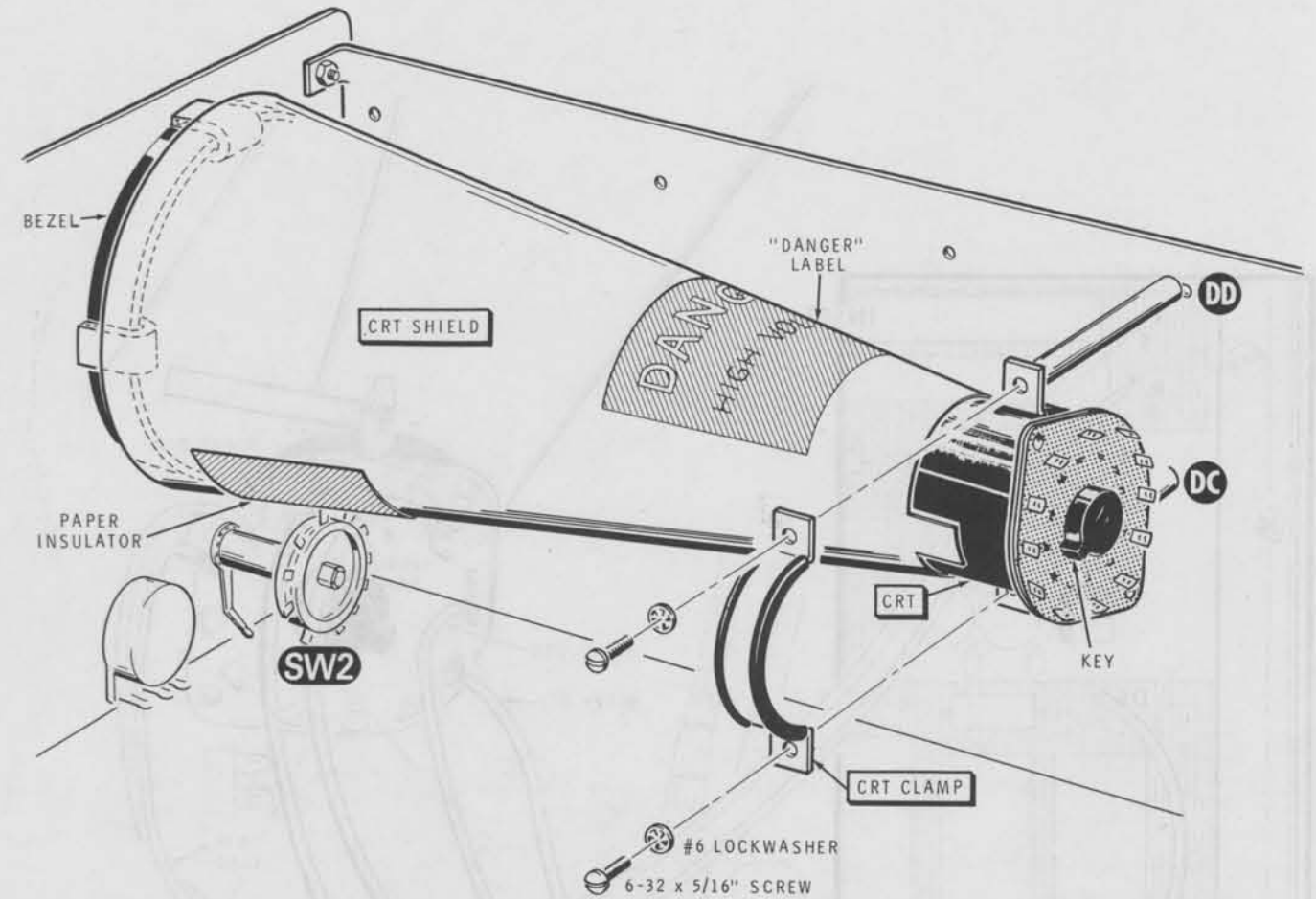

PICTORIAL 9-1



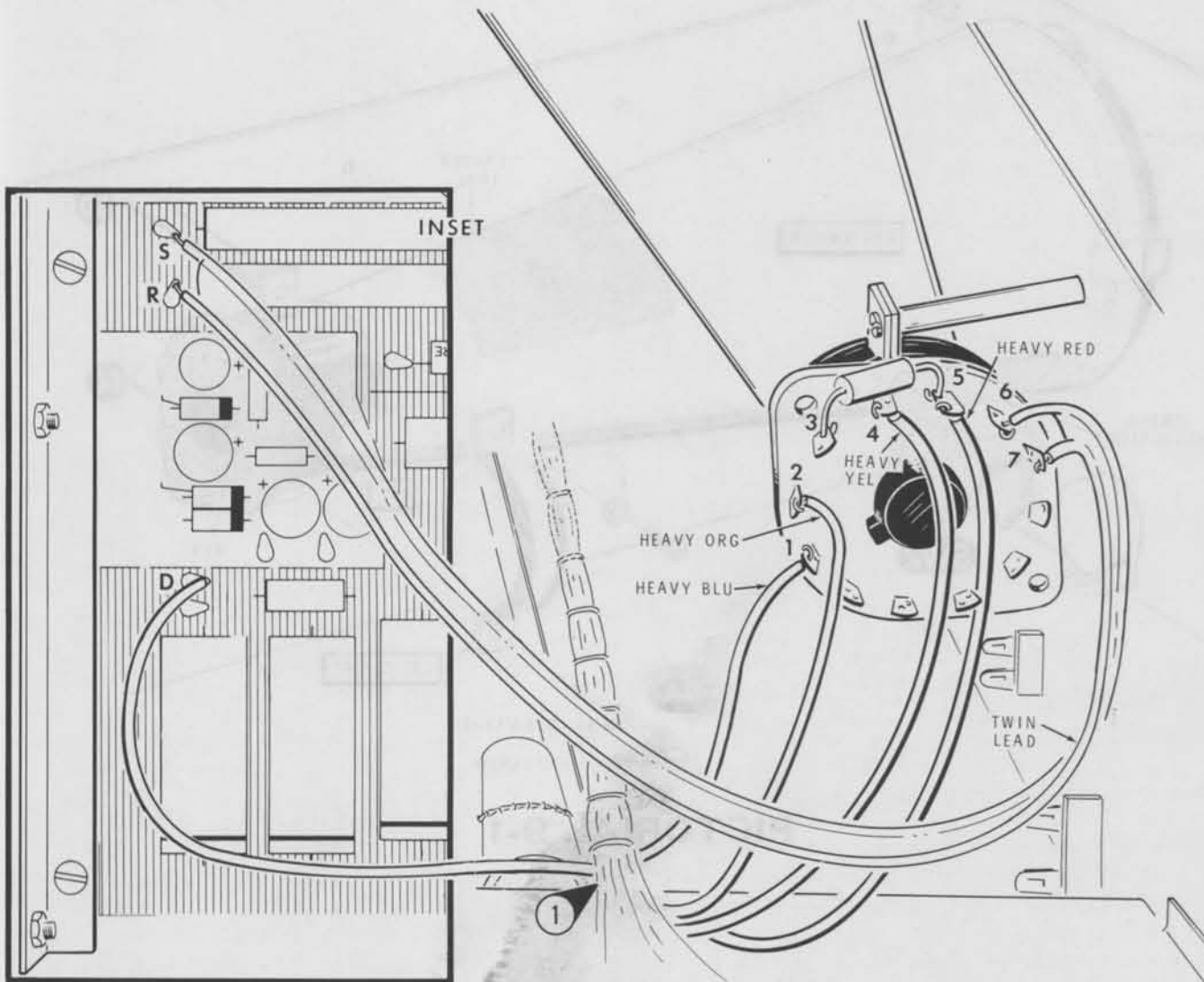

PICTORIAL 9-3

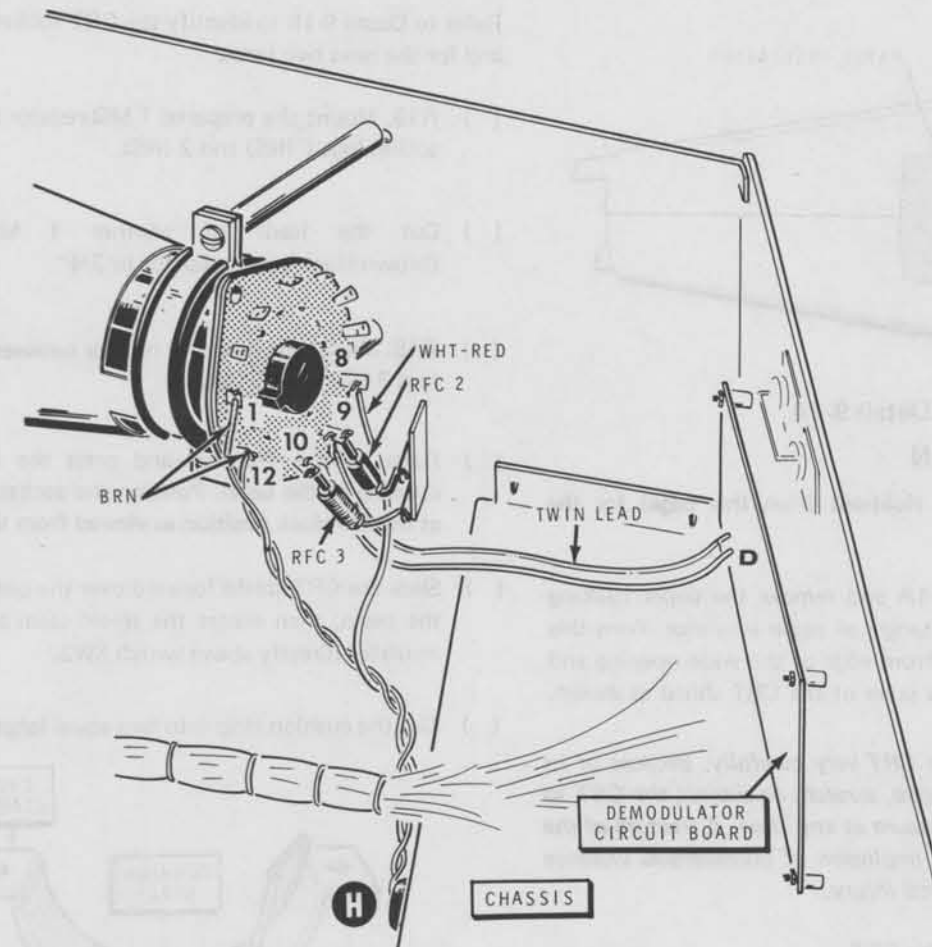

PICTORIAL 9-2

CRT WIRING

Refer to Pictorial 9-2 for the following steps.

- () Position the short 300 Ω twin lead coming from the demodulator circuit board in under all other wires and cables, and down onto the top of the chassis. Trace the twin-lead wire coming from hole D on the demodulator circuit board. Connect the free end of this wire to CRT socket lug 10 (NS). Connect the other twin-lead wire to CRT socket lug 9 (NS).
- () Connect the free lead of RFC2 to CRT socket lug 9 (S-2).
- () Twist together the two brown wires coming from grommet H in the chassis. Route them across the front of the chassis as shown and pass them under the wire harness.
- () Connect either brown wire to CRT socket lug 12 (S-1).
- () Connect the other brown wire to CRT socket lug 1 (NS).
- () Connect the free end of the RFC3 lead to lug 10 of the CRT socket (S-2).
- () Connect the white-red wire to CRT socket lug 8 (S-1).

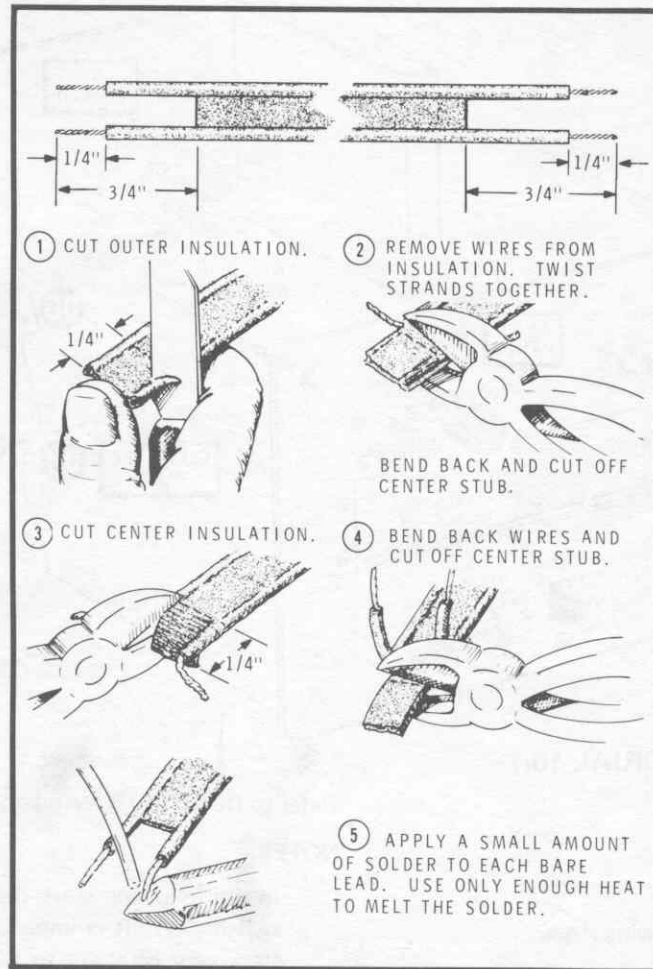

Detail 9-3A

Refer to Pictorial 9-3 (fold-out from Page 52) for the following steps.

- () Prepare a 12" heavy blue wire. Then refer to the inset drawing on the Pictorial and connect one end to hole D in the main circuit board (S-1).
- () Route this wire across the rear of the circuit board and under the wire harness, and connect it to CRT socket lug 1 (S-3).
- () Connect the heavy orange wire coming from BO#1 to CRT socket lug 2 (S-2).
- () Connect the heavy yellow wire coming from BO#1 to CRT socket lug 4 (S-1).
- () Connect the heavy red wire coming from BO#1 to CRT socket lug 5 (S-2).
- () Prepare the remaining length of 300 twin lead as shown in Detail 9-3A. Then refer to the inset drawing and connect one end of this twin lead to holes S and R in the main circuit board. Solder both wires to the foil and cut off the excess wire lengths.
- () At the other end of the twin lead, connect the lead coming from hole S to CRT socket lug 6 (S-1), and connect the other lead to CRT socket lug 7 (S-1).

Set the assembly aside temporarily.

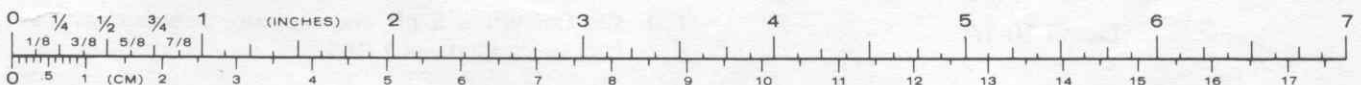

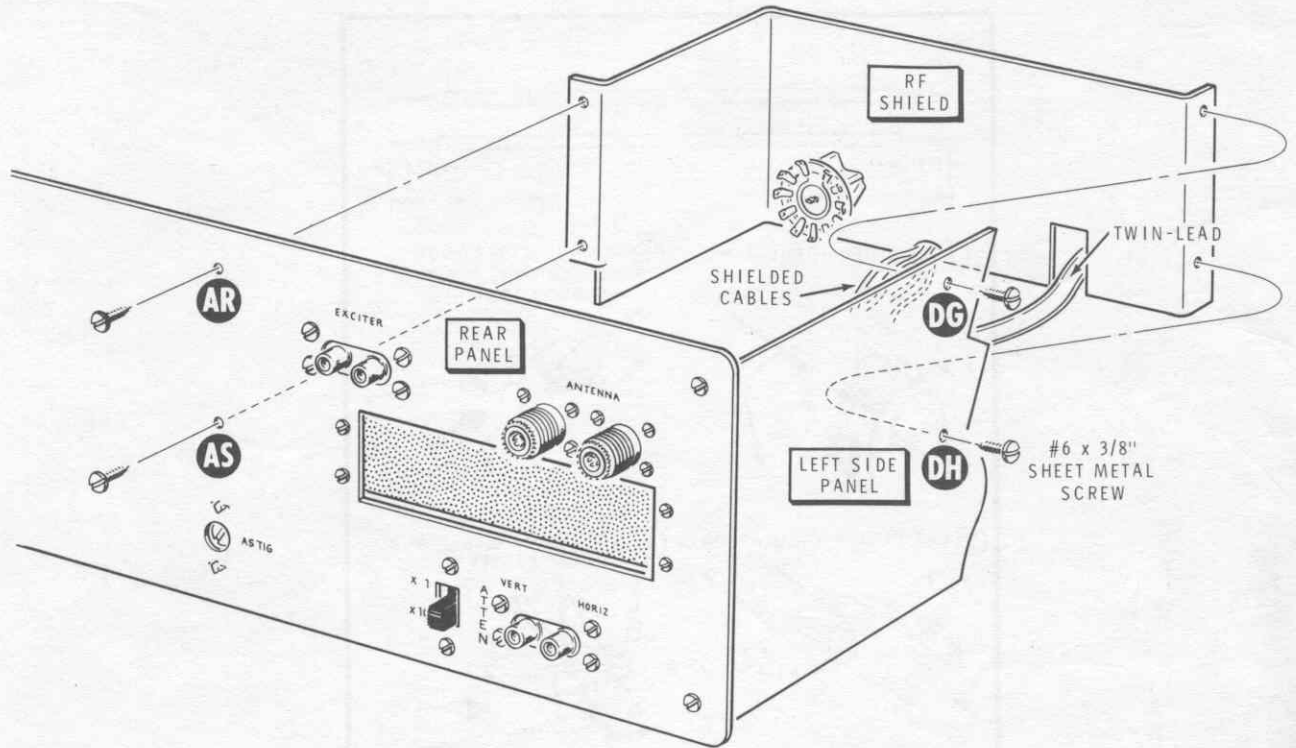

PICTORIAL 10-1

RF SHIELD ASSEMBLY

Refer to Pictorial 10-1 for the following steps.

() SW1. Refer to Detail 10-1A and mount the RF Attenuator switch (#63-1223) on the RF shield with a thick control lockwasher and a control nut. Position the switch as shown in the Pictorial.

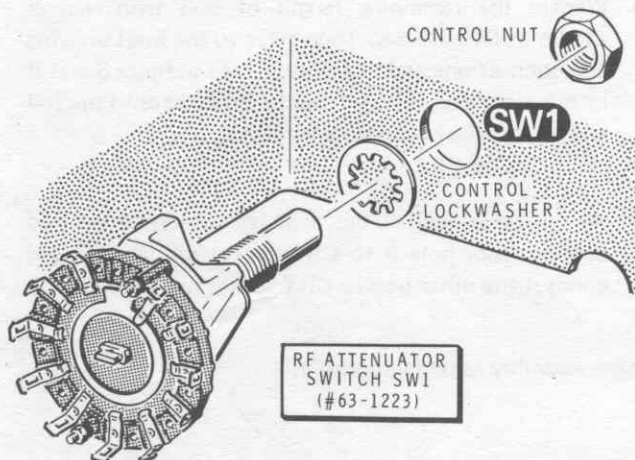

Detail 10-1A

Refer to Detail 10-1B for the following steps.

NOTES:

1. In the following steps, capacitors will be mounted on switch SW1. It is important that you perform these steps very carefully to keep solder from getting into switch contacts.
 2. To prepare each capacitor, cut its leads to 3/8". Position the capacitor leads through the designated lugs from the inside area of the switch as shown in the inset drawing on Detail 10-1B.
 3. When you solder the lugs and leads, solder from the outside of the lug. Use solder sparingly, but use enough to make a good connection.
- () C2. Connect a .56 pF phenolic capacitor (green-blue-gray) between switch SW1 lugs 11 (S-1) and 10 (NS).
 - () C3. Connect a 1 pF phenolic capacitor (brown-black-white) between switch SW1 lugs 10 (S-2) and 9 (NS).
 - () C4. Connect a 2.2 pF phenolic capacitor (red-red-white) between switch SW1 lugs 9 (S-2) and 8 (NS).
 - () C5. Connect a 5 pF disc capacitor between switch SW1 lugs 8 (S-2) and 7 (NS).

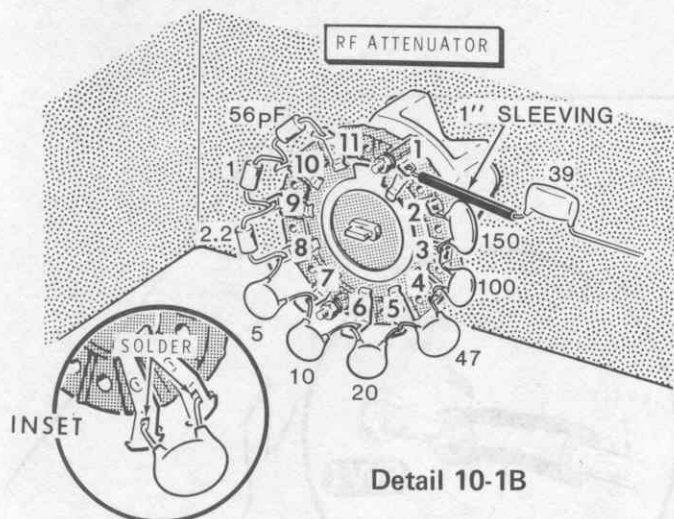

- () C1. Place the 1" sleeving on one lead of a 39 pF mica capacitor. Connect this lead of the capacitor to switch SW1 lug 1 (S-1). The free capacitor lead will be connected later.

NOTE: In the following step, to properly install the RF shield assembly, you may have to reposition the power transformer slightly. To do this, loosen the transformer mounting screws, push the transformer as far as possible toward the side panel, and then retighten the mounting screws securely.

- () Position the RF shield assembly into the chassis compartment. Route the twin lead coming from the demodulator circuit board through the rectangular opening in the shield, and route the shielded cables from the wire harness through the semicircular cutout as shown. Secure the RF shield to the rear and side panels with #6 x 3/8" sheet metal screws at AR, AS, DG, and DH.

NOTE: When you install the capacitor in the following step, be especially careful to avoid shorting its leads to the switch mounting stud.

- () C6. Connect a 10 pF disc capacitor between switch SW1 lugs 7 (S-2) and 6 (NS).
- () C7. Connect a 20 pF disc capacitor between switch SW1 lugs 6 (S-2) and 5 (NS).
- () C8. Connect a 47 pF disc capacitor between switch SW1 lugs 5 (S-2) and 4 (NS).
- () C9. Connect a 100 pF disc capacitor between switch SW1 lugs 4 (S-2) and 3 (NS).
- () C11. Connect a 150 pF disc capacitor between switch SW1 lugs 3 (S-2) and 2 (NS).
- () Cut a 1" length of sleeving.

Refer to Pictorial 10-2 for the following steps.

- () Connect the free end of the green wire coming from E on the demodulator circuit board to switch SW1 lug 2 (S-2).
- () Cut a 1" length of sleeving. Place this sleeving on the free lead of the 39 pF mica capacitor coming from switch SW1 lug 1.
- () Form a small loop in the end of 47 kΩ resistor R1 lead as shown. Pass the free end of the 39 pF mica capacitor through this loop. Crimp the two leads together. Then solder the connected leads and cut off any excess lead lengths.

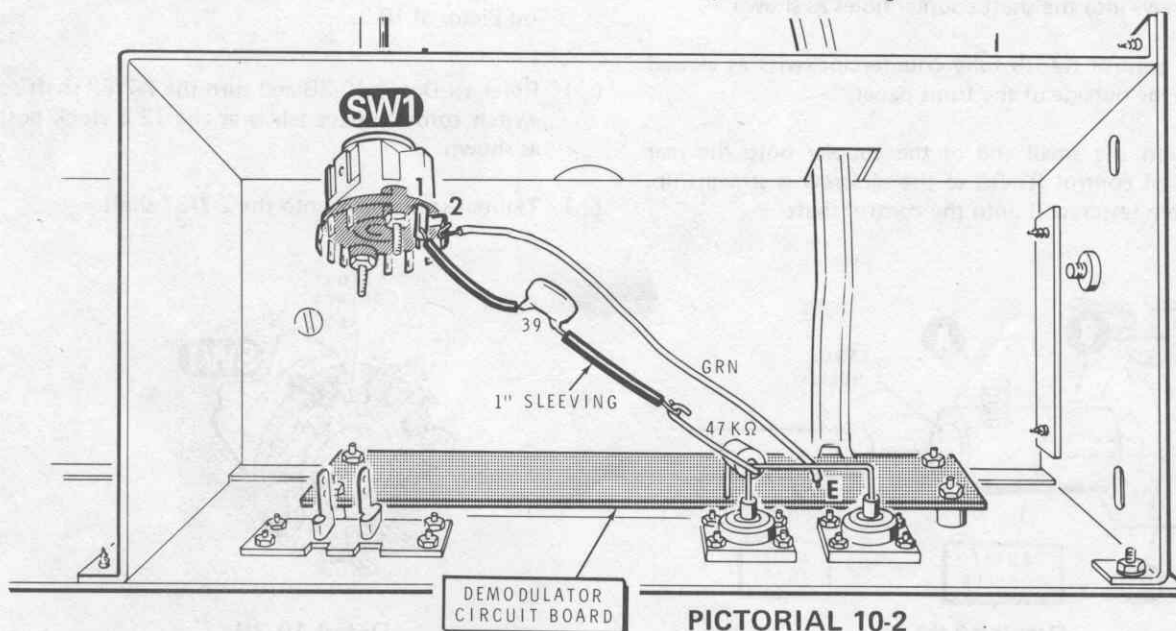

PICTORIAL 10-2



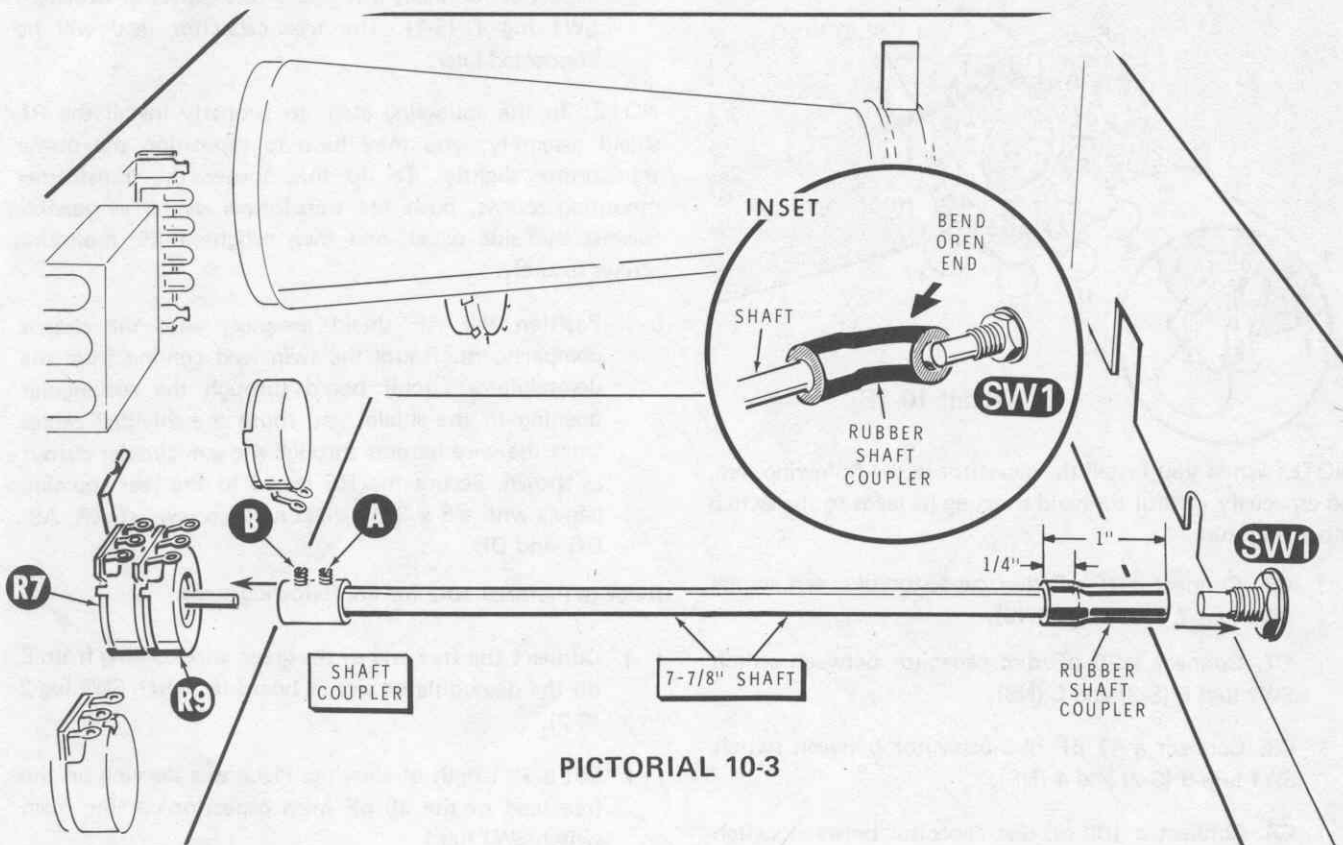

PICTORIAL 10-3

Refer to Pictorial 10-3 for the following steps.

- () Place the 1" rubber shaft coupler 1/4" onto one end of the 7-7/8" shaft.
- () Refer to Detail 10-3A and start two 6-32 x 1/8" setscrews into the shaft coupler holes as shown.
- () Turn control R7-R9 fully counterclockwise as viewed from the outside of the front panel.
- () Position the small end of the coupler onto the rear shaft of control R7-R9 so the setscrew is straight up. Tighten setscrew B onto the control shaft.
- () Position the end of the 7-7/8" shaft into the larger end of the coupler. Do not tighten the setscrew.
- () Work the open end of the rubber shaft coupler onto the shaft of switch SW1 as shown in the inset drawing on Pictorial 10-3.
- () Refer to Detail 10-3B and turn the 7-7/8" shaft so the switch rotor contact tab is at the 12 o'clock position as shown.
- () Tighten setscrew A onto the 7-7/8" shaft.

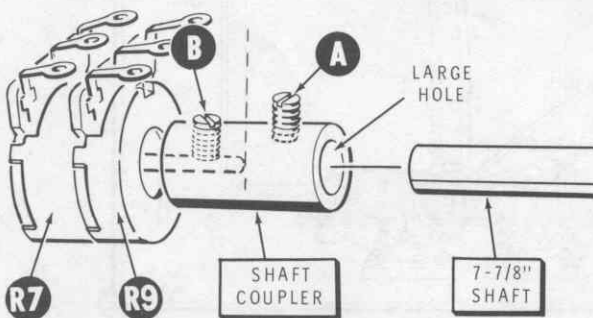

Detail 10-3A

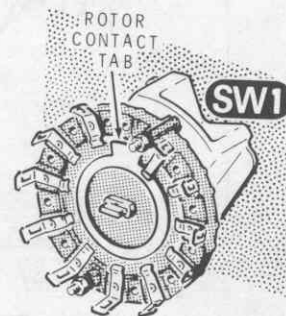

Detail 10-3B

KNOB INSTALLATION

Refer to Pictorial 11-1 (fold-out from this page) for the following steps.

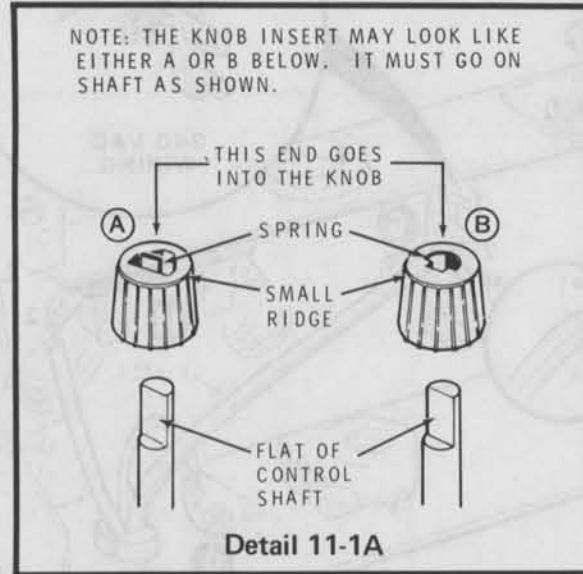

NOTE: Refer to Detail 11-1A and notice that the knob insert is tapered. When you place one of these inserts on a shaft, be sure the smaller (tapered) end faces out or the knob will not slide onto the insert. If you are not sure which end is smaller, roll the insert across a flat surface; the insert will gradually turn toward the smaller end.

- () Refer to Detail 11-1B and place long knob inserts on the Intensity, Mode, and Focus shafts.
- () Firmly press a small round knob onto the insert on the Intensity shaft. Then remove both the knob and insert.
- () Refer to inset drawing #1 on the Pictorial and tap the insert into the knob with a hammer and a nut driver (or other suitable tool) until the insert is fully seated.
- () Replace the knob and insert on the Intensity shaft.
- () In the same manner, install knobs onto the inserts on the Mode and Focus shafts.

Refer to Detail 11-1C for the following steps.

- () Place a felt washer onto the Horizontal Gain-Horizontal Pos (Position) shaft.
- () Place a felt washer onto the Vertical Gain-Vertical Pos (Position) shaft.

NOTE: In the following steps you will install the short knob inserts and the lever knobs. Each short knob insert is made so it will fit the control shaft incorrectly if it is inverted. To properly install the insert, it must be placed on the shaft so the recessed part of the short lug is toward the front panel and the flush side is toward the end of the shaft. See the inset drawing on Detail 11-1C.

- () Install short knob inserts on the Vertical Pos, Horizontal Pos, and Range shafts. Turn the Range switch and the two controls to their clockwise positions.
- () Press a lever knob onto the Range switch knob insert and position the lever over the "100 Hz" marking on the front panel. Do this carefully. When you are sure the knob is correctly positioned, push it firmly onto the insert. Then remove both knob and the insert.
- () Refer to the inset drawing on the Pictorial and carefully tap the knob insert into the knob until it is flush with the front surface on the knob. Replace the knob and insert on the Range switch.
- () Similarly, push another lever knob onto the insert on the Vertical Pos control. Position the lever at 11 o'clock as shown on the Pictorial. Remove the knob and insert, tap the insert into the knob, and then replace the knob and insert on the shaft.
- () In the same manner, install a lever knob and insert on the Horizontal Pos shaft.

Refer to Detail 11-1D for the following steps.

- () Start an 8-32 x 1/4" setscrew into each of the large round knobs.
- () Turn the center (small) shafts on the Vertical Gain, the Sweep, and the Horizontal Gain controls fully counterclockwise.
- () Place a small brass bushing onto each of these control shafts. Position the slot in the bushing at 4 o'clock as shown in the Detail.
- () Place a large round knob onto the Vertical Gain shaft. Position the knob pointer at 7 o'clock; then tighten the knob setscrew. Leave approximately 1/32" of space between the large knob skirt and the lever knob.
- () In the same manner, install large round knobs on the Sweep and the Horizontal Gain shafts.

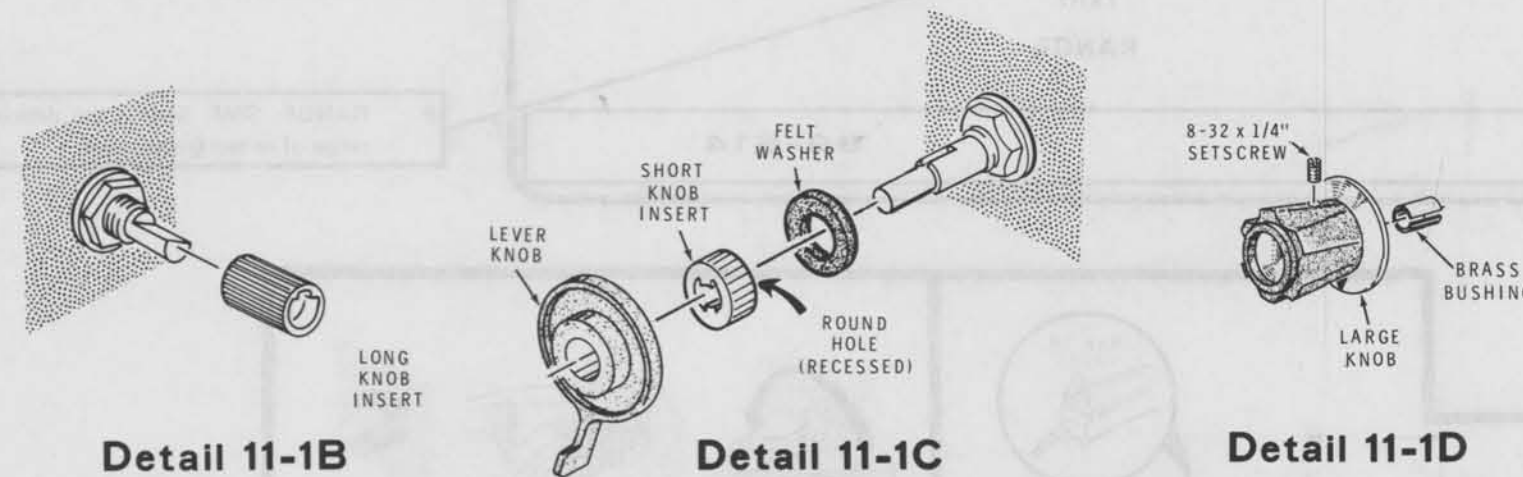
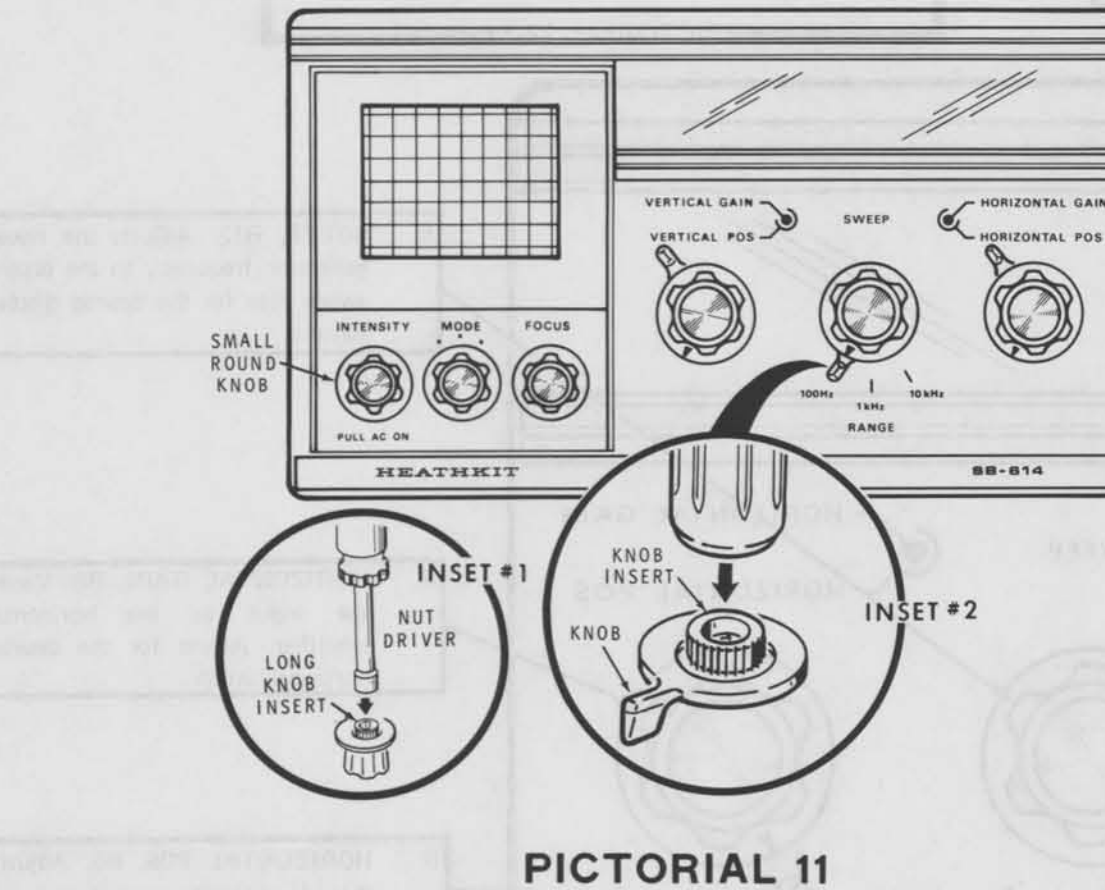

Detail 11-1B

Detail 11-1C

Detail 11-1D

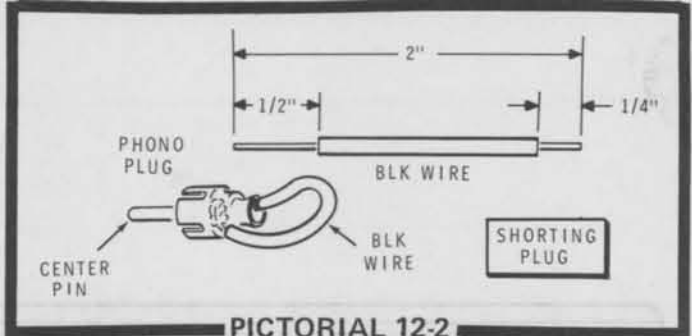
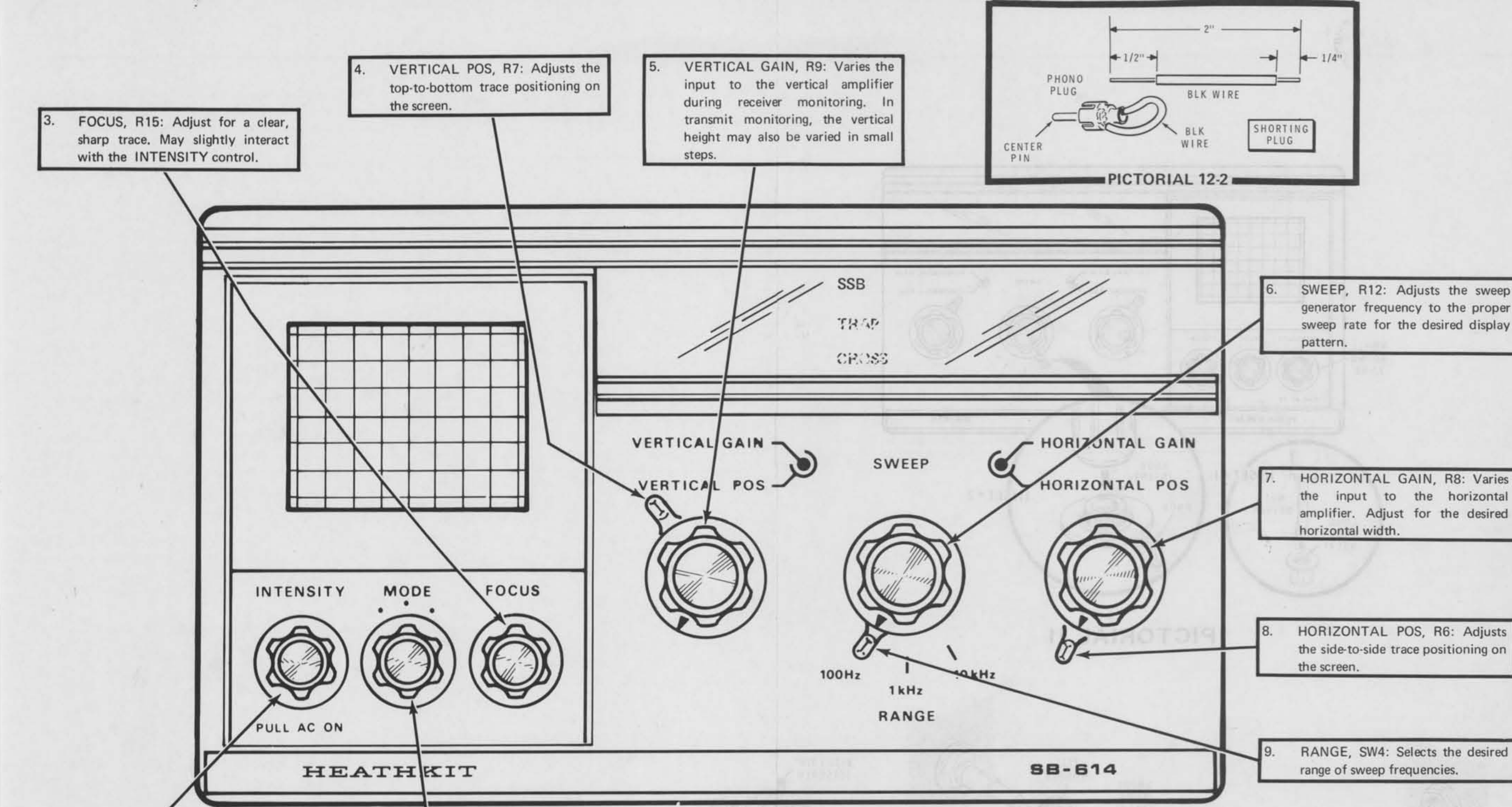

LINE CORD INSTALLATION

Refer to Pictorial 12-1 for the following steps.

- () Refer to Detail 12-1A and split the outer insulation of the line cord for 4 inches, as follows, so you do not cut into the protective insulation for the AC leads.
- 1. Use a knife point to score a line BETWEEN the two grooves.
- 2. Turn the cord over and repeat step 1.
- 3. Grasp the lead ends by the insulation and pull the leads apart. The line cord will separate on the scored lines.

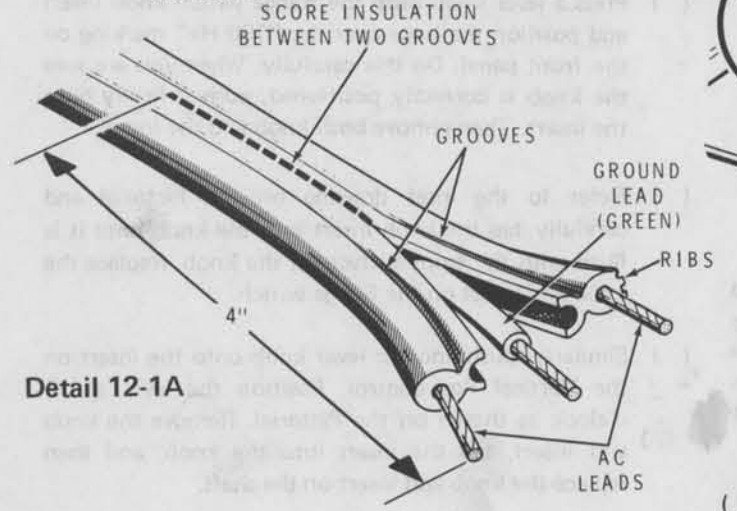

Important Note: Study Detail 12-1A carefully and identify the ribbed and smooth line cord leads.

- () Refer to Detail 12-1B and cut the green lead to 1" and the smooth-insulation lead to 2". Remove 1/4" of insulation from each cut lead; then twist the wire ends tightly and apply a small amount of solder to hold the strands together.

NOTE: As you connect each of the line cord leads in the following steps, securely wrap each wire end around the designated lug to assure a good mechanical connection.

- () Pass the free end of the line cord through rear panel hole M as shown in the Pictorial. Connect the green lead to solder lug Q (S-1).
- () Connect the ribbed (long) line cord lead to terminal strip G lug 2 (S-3). [NOTE: Refer to inset drawing #2 on the Pictorial and connect the ribbed (long) line cord lead to terminal strip G lug 1 (S-2), if your line voltage is 240 VAC.]
- () Connect the smooth line cord lead to fuseholder F1 lug 2 (S-1).

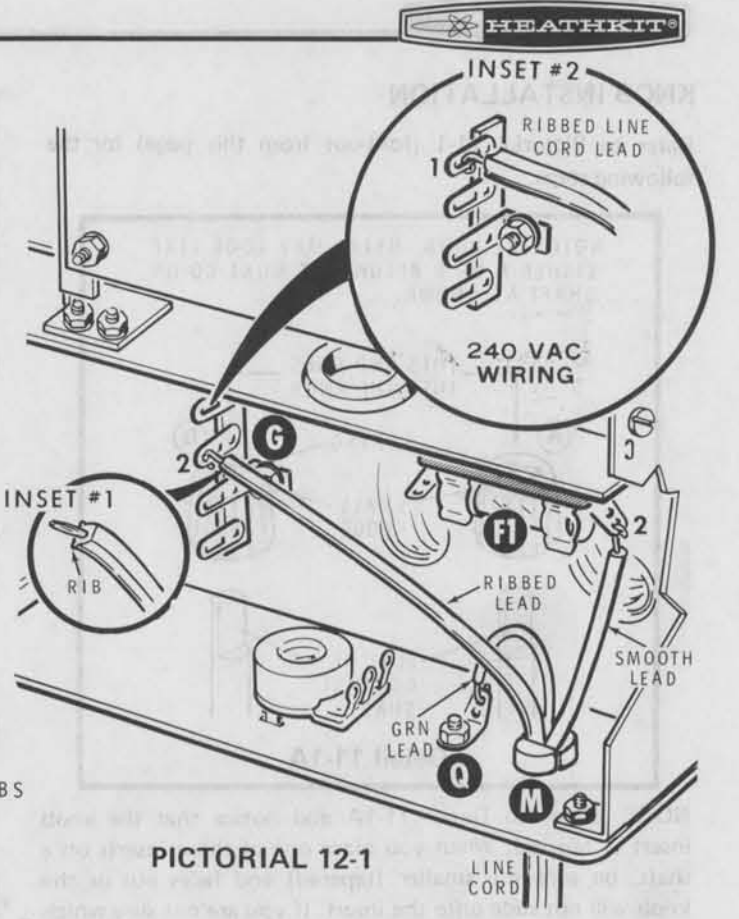

- () Refer to Detail 12-1C and place a strain relief on the line cord close to the outside of the rear panel. Then push the strain relief into hole M as shown.

Refer to Pictorial 12-2 for the following steps.

- () Cut a 2" length of black wire. Remove 1/4" of insulation from one wire end, and 1/2" of insulation from the other end.
- () Push the 1/2" prepared end of the black wire into the center pin of a phono plug as shown. Heat the tip of the center pin and allow solder to flow into the opening in the tip.
- () Press the free end of the black wire onto the outer shell of the phono socket and apply solder to hold it in place.

This completes the assembly of your shorting plug.

This completes the "Step-by-Step" assembly of your Station Monitor, except for "Final Assembly" to follow later. Carefully inspect all connections for loose wires or unsoldered connections. Remove any wire clippings or solder splashes. Then proceed to "Initial Tests."

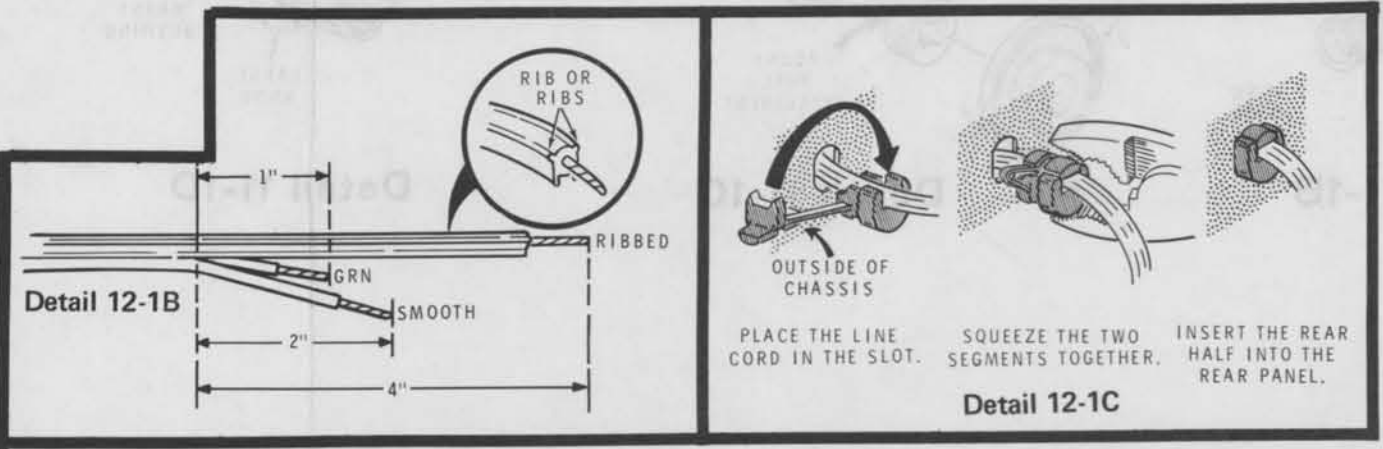
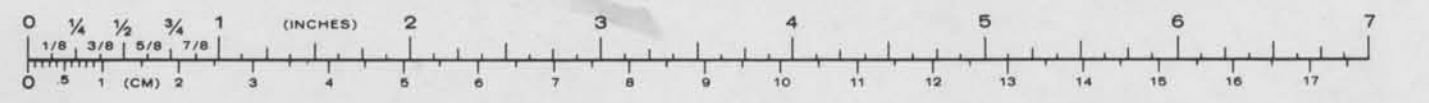

Figure 2-1



INITIAL TESTS

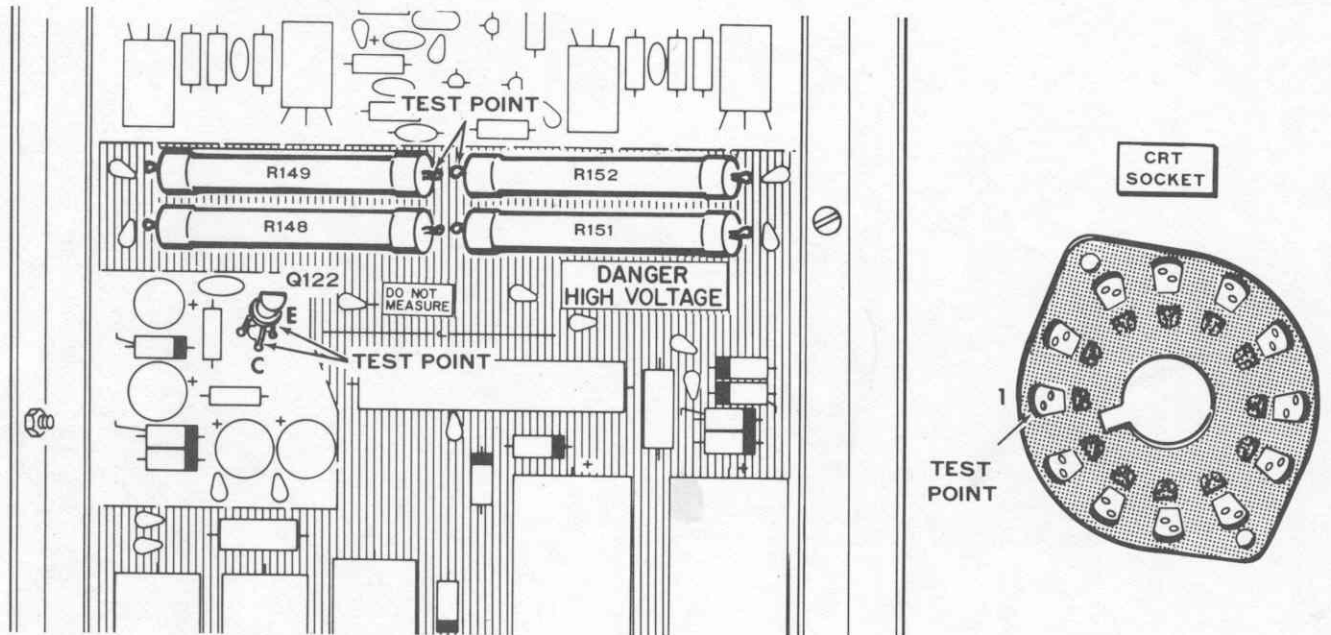

Figure 1-1

Refer to Figure 1-1 for the locations of the test points called out in the following steps.

If an ohmmeter is available, make the following checks before you apply power to the unit. If you do not get the correct indication, refer to "In Case of Difficulty" on Page 85. Connect the negative meter lead to chassis ground. NOTE: Allow a few seconds for capacitors to charge.

Connect the Positive Meter Lead To:	Correct Reading
() CRT socket lug 1	3 MΩ or greater.
() Junction of resistors R148, R149, R151, and R152	100 kΩ or greater.
() Emitter (E) of transistor Q122	150 Ω or greater.
() Collector (C) of transistor Q122	450 Ω or greater.

This completes the "Initial Tests." Proceed to "Adjustments."

INITIAL TESTS

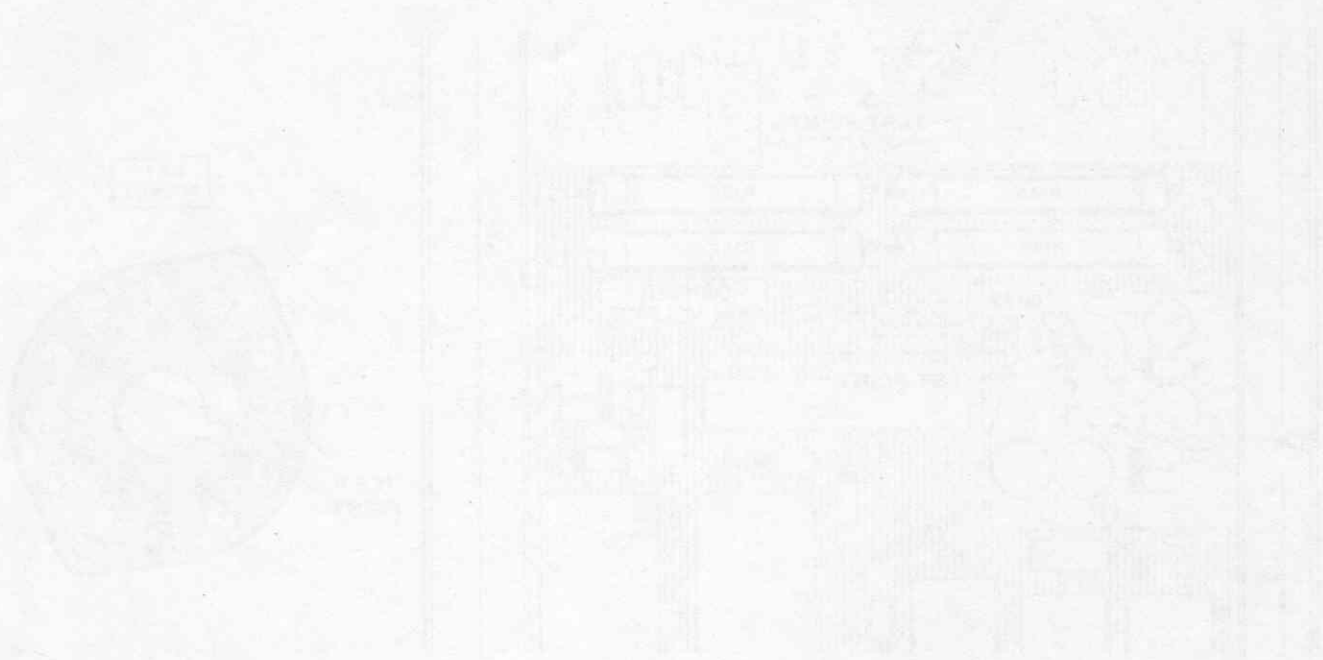

[Faint, illegible text, likely bleed-through from the reverse side of the page.]

ADJUSTMENTS

TRACE

Refer to Figure 2-1 (fold-out from Page 58). In the following steps, all controls will be called out in capital letters just as they appear on the Station Monitor. The following markings are abbreviated. The numbers in parentheses refer to the numbered paragraphs on Figures 2-1 and 2-3.

<u>MARKING</u>	<u>FULL MEANING</u>
Front Panel Controls (Figure 2-1)	
VERTICAL POS (4)	Vertical Position
HORIZONTAL POS (8)	Horizontal Position
Circuit Board Controls (Figure 2-2, fold-out from Page 65)	
VERT BAL	Vertical Balance
HORIZ BAL	Horizontal Balance
Rear Panel Controls (Figure 2-3, fold-out from Page 65)	
ASTIG (10)	Astigmatism
ATTEN (11)	Attenuator (switch)

Do not plug the AC line cord into a power outlet until you are so instructed. It is suggested that you read this entire section of the Manual before you perform any of the following steps in order to clearly understand the overall operation of the Monitor. Refer to the "In Case of Difficulty" section (Page 85) if you do not get the proper response to any of the following adjustments.

Refer to Figure 2-1 for the following adjustments.

- MODE switch — fully counterclockwise.
- SWEEP control — fully clockwise.
- HORIZONTAL GAIN control — fully counterclockwise.
- HORIZONTAL POS control — center of rotation.
- VERTICAL GAIN control — fully counterclockwise.
- VERTICAL POS control — center of rotation.
- FOCUS control — center of rotation.
- INTENSITY control — pushed in (OFF) — fully counterclockwise.
- RANGE switch — 1 kHz position.

Refer to Figure 2-2 (fold-out from Page 65) for the following adjustments.

- Vert Bal control. Preset the control stop-tab to the 3 o'clock position.
- Horiz Bal control. Preset the control stop-tab to the 9 o'clock position.

Refer to Figure 2-3 (fold-out from Page 65) for the following adjustments.

- () ATTEN switch – X1 (up) position.
- () ASTIG control – center of rotation.

CAUTION: VOLTAGES IN THIS INSTRUMENT ARE DANGEROUS. Use extreme care whenever you operate or handle it when it is not in its cabinet. The dangerous voltage areas are shown in the "Chassis Photographs" (Page 97). Some of the highest voltages in the Monitor appear at the lugs of the CRT socket, the FOCUS control, and the INTENSITY control. These voltages could be fatal. Anytime a part in these areas must be handled, turn off the power, remove the line cord from its outlet, and use a screwdriver and an insulated lead to short the positive (+) leads of the large electrolytic capacitors to the chassis.

- () Plug the line cord into an AC outlet.
- () Pull the INTENSITY knob out to its ON position. Then turn it clockwise to approximately 3/4 of its rotation. The SSB indicator lamp and the CRT filament should glow.
- () Allow one minute for the CRT to warm up. A spot should appear on the CRT screen. If no spot appears, simultaneously adjust the VERTICAL POS and the HORIZONTAL POS controls until you locate the spot. If no spot appears, turn the unit off and refer to "In Case of Difficulty" (Page 85).

- () Turn the Monitor off and disconnect the line cord.

NOTE: The Mode indicator lamps may not go out immediately when the power is turned off. This is normal, as the lamp is connected to the B+ circuit and the electrolytic capacitors discharge slowly.

- () Refer to Figure 2-4 and temporarily connect a 5" length of hookup wire from EE to BB (Marked on the top of the board) on the foil side of the main circuit board as shown.
- () Plug the line cord in and turn the unit on.
- () Adjust the INTENSITY control until the spot is clearly visible but not too bright.
- () Alternately adjust the FOCUS and ASTIGMATISM controls for the smallest, sharpest spot.

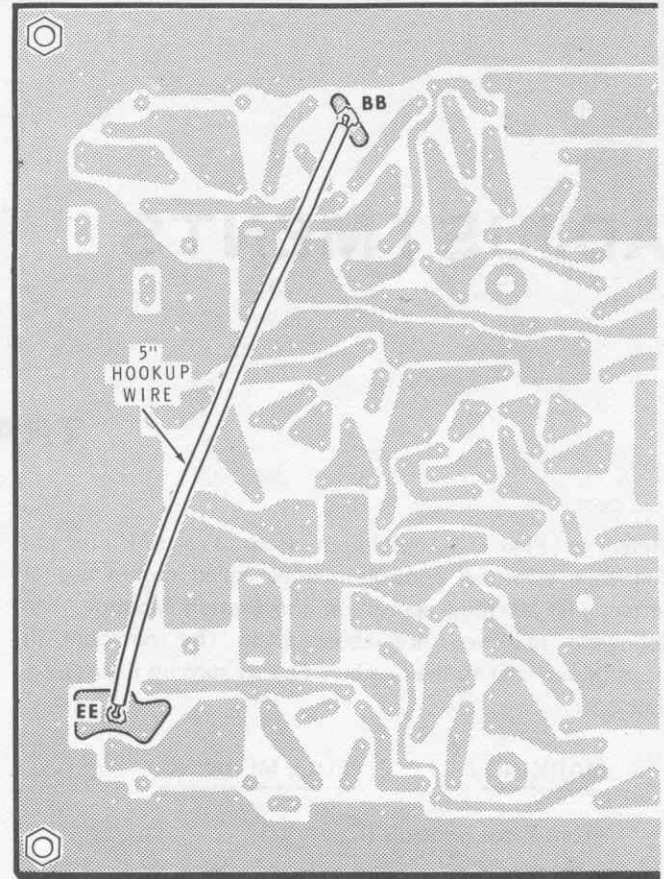

Figure 2-4

- () Rotate the HORIZONTAL POS control and notice that the spot moves horizontally across the CRT screen.
- () Rotate the VERTICAL POS control and notice that the spot moves vertically on the screen.
- () Adjust the HORIZONTAL POS and the VERTICAL POS controls to center the spot on the screen.
- () Slowly turn the HORIZONTAL GAIN control clockwise. The spot should now become a horizontal line or trace. **NOTE:** If the trace expands in only one direction, refer to Figure 2-2 and adjust the HORIZONTAL BAL control slightly until the line expands equally in both directions. This adjustment is not critical at this time.

NOTE: If the horizontal line is not parallel with the horizontal lines on the grid screen, perform the following four steps. If the lines are parallel, omit the next four steps.

- () Observe the slant of the trace on the CRT and estimate how far the CRT should turn to make the lines parallel.
- () Turn off the power and unplug the line cord. Use a screwdriver with an insulated handle and momentarily short the positive (+) leads of the large electrolytic capacitors to chassis ground. This will assure a complete discharge.
- () Loosen the clamp (if necessary) at the base of the CRT and rotate the tube the amount estimated to make the trace horizontal.
- () Plug in the line cord and turn the Monitor on. Check to see that the trace is horizontal. If necessary, turn the unit off and repeat these four steps until you get the desired results.
- () Be sure the CRT face is against the graticule; then tighten the CRT clamp screws.
- () Plug the line cord into the AC receptacle and turn the unit on.
- () Turn the MODE switch to illuminate the TRAP indicator. The screen may be blank; the spot is automatically clamped to the right and may or may not be visible on the screen.
- () Turn the HORIZONTAL GAIN fully counterclockwise.
- () Turn the MODE switch to illuminate the CROSS indicator. The spot should appear in the center of the screen.
- () Return the MODE switch to the SSB position.
- () Turn the VERTICAL GAIN control fully clockwise. You should observe a vertical trace line at the center of the screen. If the trace expands more in one direction than in the other, adjust the VERT BAL control on the main circuit board for equal trace expansion.

NOTE: There will be an interaction between the VERT BAL and the VERTICAL POS controls, between the HORIZ BAL and the HORIZONTAL POS controls, and between the FOCUS and the ASTIGMATISM controls. Each time you adjust one of these controls, recheck the operation of the others to be sure they remain correctly set. Always focus and recenter the spot.

- () With the VERTICAL GAIN control fully clockwise, turn the HORIZONTAL GAIN control until you see a diagonal line as shown in Figure 2-5A. This line may appear as shown in Figures 2-5B through 2-5E. If so, correct the trace to a straight diagonal line by making the adjustment suggested with the appropriate Figure.

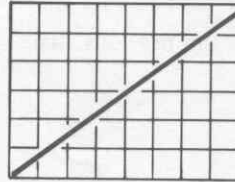

Figure 2-5A

CORRECT PATTERN

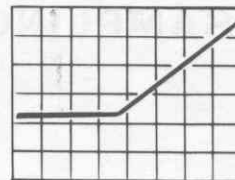

Figure 2-5B

Adjust the VERT BAL control clockwise for a straight diagonal line.

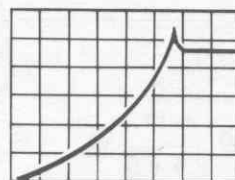

Figure 2-5C

Adjust the VERT BAL control counterclockwise.



Figure 2-5D

Adjust the HORIZ BAL control clockwise.

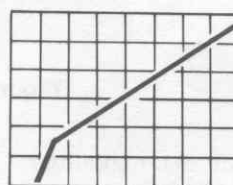

Figure 2-5E

Adjust the HORIZ BAL control counterclockwise.

NOTE: It may be necessary to alternately adjust both the HORIZ BAL and the VERT BAL controls to obtain the desired trace.

- () Adjust the VERT BAL control clockwise until the trace begins to distort in the upper right corner of the screen. Observe the control setting. Turn the control counterclockwise until the trace begins to distort in the lower left corner of the screen. Observe this control setting. Set the VERT BAL control midway between the two observed settings.
- () Repeat the operation described in the previous step, only with the HORIZ BAL control.
- () Turn the VERTICAL GAIN and the HORIZONTAL GAIN controls fully counterclockwise.
- () Alternately adjust the FOCUS and ASTIGMATISM controls for the smallest, sharpest spot.
- () Turn the Monitor OFF. Remove the jumper wire from the foil side of the main circuit board.

RF SAMPLING CHECKOUT

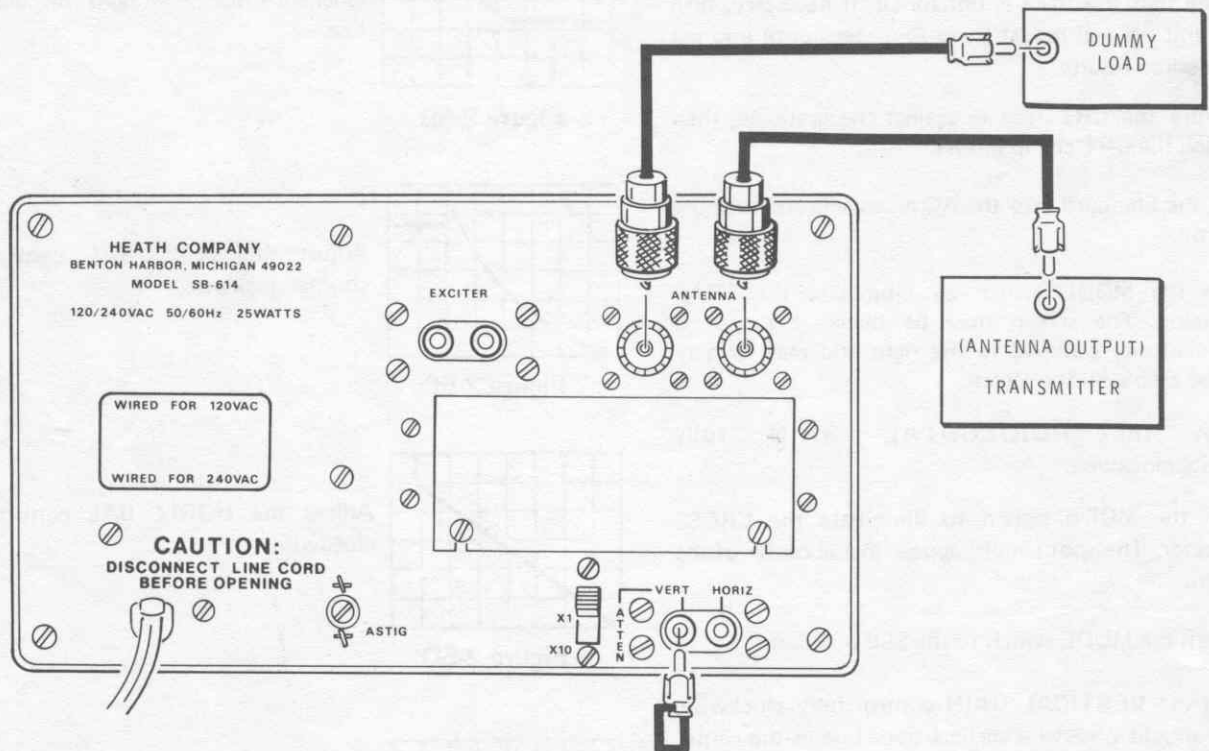

Figure 3-1

- () Refer to Figure 3-1 and connect the transmitter output to the Station Monitor as shown. Connect a 50 Ω dummy load to the remaining open ANTENNA jack on the rear of the Monitor.
- () Install the phono shorting plug into the VERT input phono socket.
- () Refer to Figure 3-2 and temporarily connect a 2-1/2" length of hookup wire from the Antenna jack bus wire to lugs 2 and 3 of the EXCITER dual phono socket.
- () Apply AC power to the transmitter and to the Monitor.

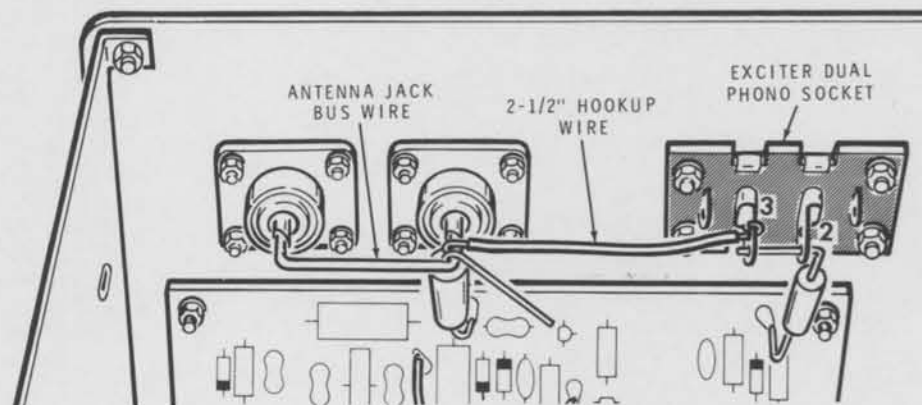

Figure 3-2

() On the Station Monitor, set the controls and switches as follows:

- RANGE switch – 100 Hz.
- MODE switch – SSB.
- VERTICAL GAIN – fully counterclockwise.
- HORIZONTAL GAIN – turn clockwise for a full screen-width trace.

IMPORTANT: Always keep the amplitude of the CRT display within the graticule (screen lines) by adjusting the VERTICAL GAIN control. Failure to keep the display amplitude within the graticule viewing area can cause toroid coil L201 and resistor R201 to overheat, and may result in damage to either of these parts. A good height pattern is from 1/2" to 1". When you adjust the VERTICAL GAIN control, any RF pattern displayed will increase or decrease in small height increments; this is normal.

() Tune the transmitter for a normal output. Observe the pattern on the Monitor screen.

() Transmit in the SSB mode of operation and talk into the microphone. Adjust the SWEEP control for a series of "Christmas-tree" patterns on the Monitor screen. See Figure 3-3.

() Turn the Monitor MODE switch to the TRAP position.

() Key the transmitter in the SSB mode and talk into the microphone. Stop talking and observe that the CRT pattern becomes a spot and moves to the right and off the screen.

() Turn off the transmitter and the Station Monitor power.

() Remove the temporary jumper wire from the ANTENNA and EXCITER jacks.

() Unplug the line cord.

() Remove the shorting plug from the VERT input phono socket.

This completes the "Adjustments" of your Station Monitor.



Figure 3-3

NOTE: A two-tone generator connected to the microphone input of your transmitter will produce a uniform trapezoid ("Christmas-tree") pattern on the Monitor screen. If you have a two-tone generator, use it in place of the microphone in the following steps.

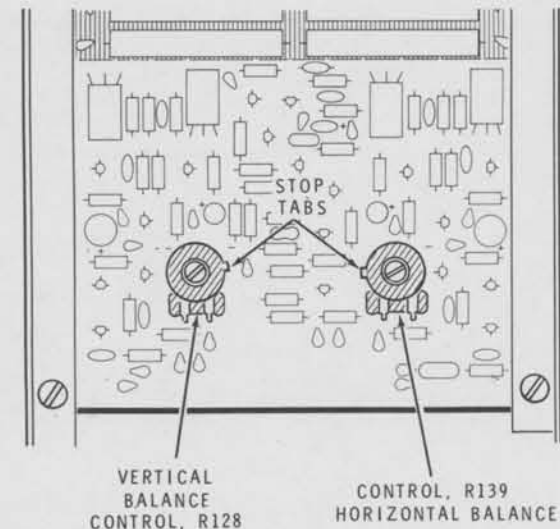
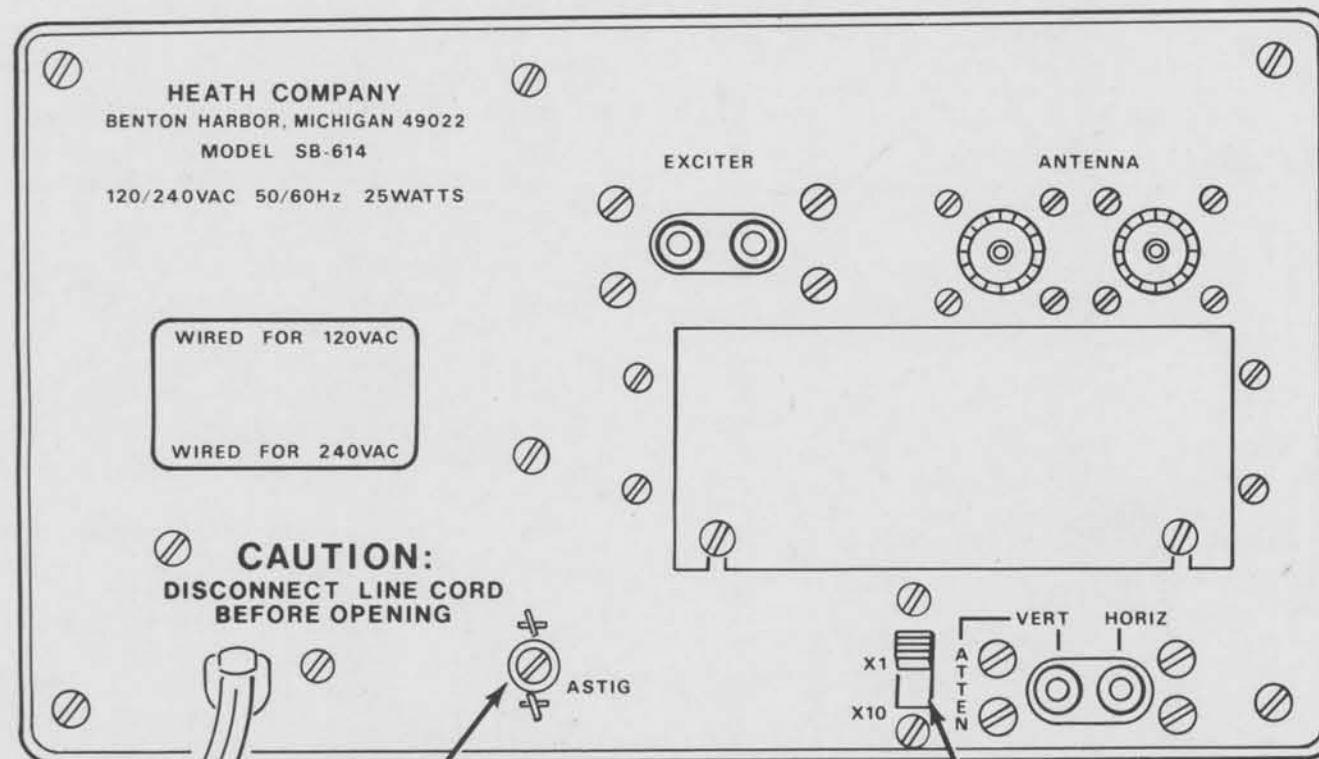

Figure 2-2



10. **ASTIGMATISM, R21:** This control adjusts the shape of the spot on the CRT. It is used in conjunction with the FOCUS control to obtain the sharpest, clearest display on the screen.

11. **VERTICAL ATTENUATOR, SW3:** In the X10 position this switch reduces input signal strength by a factor of 10, increasing the overall capability of the vertical amplifier.

Figure 2-3

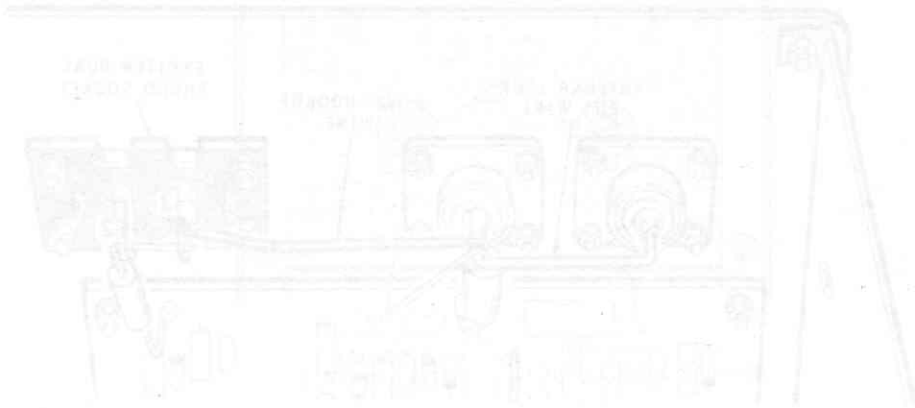

Figure 3-2

Figure 3-2

1. Turn the power switch to the "ON" position. The CRT should glow. If it does not, check the power supply and CRT connections. See Figure 3-2.

2. Turn the power switch to the "OFF" position.

3. For the remainder of the test, keep the power switch in the "OFF" position. Do not touch the CRT or any other components. See Figure 3-2.

4. Turn off the power switch and the power supply.

CAUTION
5. Do not touch the CRT or any other components. See Figure 3-2.

6. Turn the power switch to the "ON" position.

7. Remove the chassis and the CRT sections.

8. Turn the power switch to the "OFF" position.



Figure 3-3

Figure 3-2

1. On the left monitor, for the horizontal section, the following:

Remove the CRT section. See Figure 3-2. The CRT section is shown in Figure 3-3.

IMPORTANT: Always use the height of the CRT display when the picture tube is being adjusted. The vertical gain control should be kept in the "OFF" position. The horizontal gain control should be kept in the "OFF" position. The vertical gain control should be kept in the "OFF" position. The horizontal gain control should be kept in the "OFF" position.

2. Turn the chassis for a second output. Observe the following:

NOTE: A picture tube that is not properly adjusted will produce a picture that is distorted. The picture should be adjusted so that it is a uniform rectangular shape. The picture should be adjusted so that it is a uniform rectangular shape. The picture should be adjusted so that it is a uniform rectangular shape.

FINAL ASSEMBLY

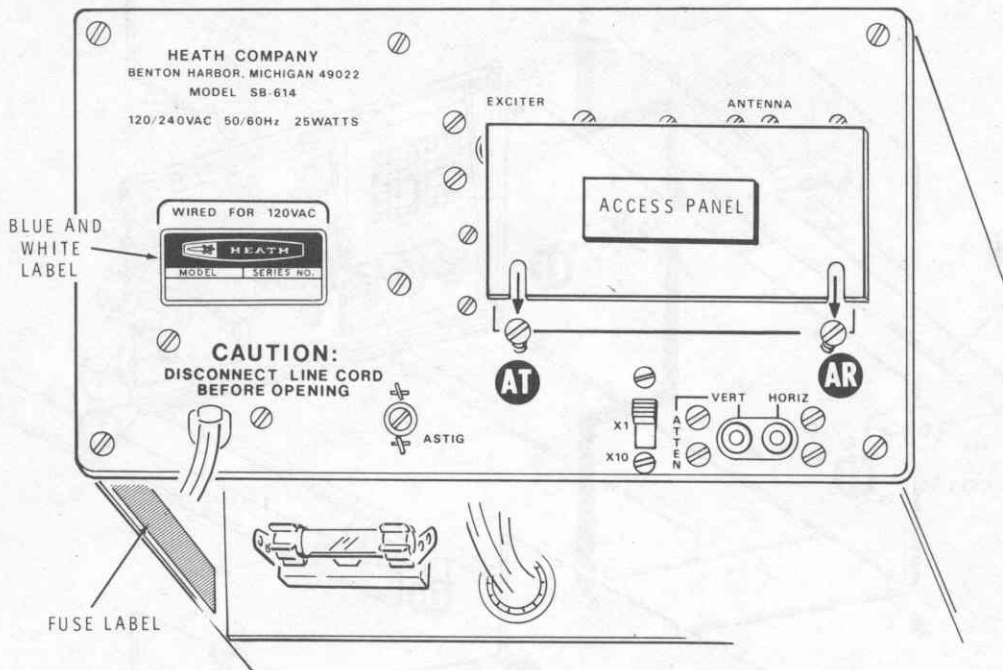

PICTORIAL 13-1

Refer to Pictorial 13-1 for the following steps.

- () Loosen the chassis mounting screws at AT and AR. Position the slots in the lower edge of the access panel down onto the mounting screws as shown. Tighten screws AT and AR.

NOTE: In the following step the blue and white identification label will be mounted on the kit. Refer to the numbers on this label in any communications you have with the Heath Company about your kit.

- () Remove the paper backing from the blue and white label and press the label in place on the rear panel. Do this exactly as shown in the Pictorial to expose the

words "Wired for 120 VAC" if this is the voltage in your area. If your kit is wired for the higher voltage, cover "Wired for 120 VAC" with the label, and expose "Wired for 240 VAC."

- () On the fuse label, if your kit is wired for 120-volt operation, write "1/2A-S/B" in the spaces provided. If it is wired for 240-volt service, write "1/4A-S/B" for your fuse value.
- () Remove the paper backing from the fuse label. Then press the label in place on the lower edge of the side panel between the rear panel and the front edge of the chassis, as shown.

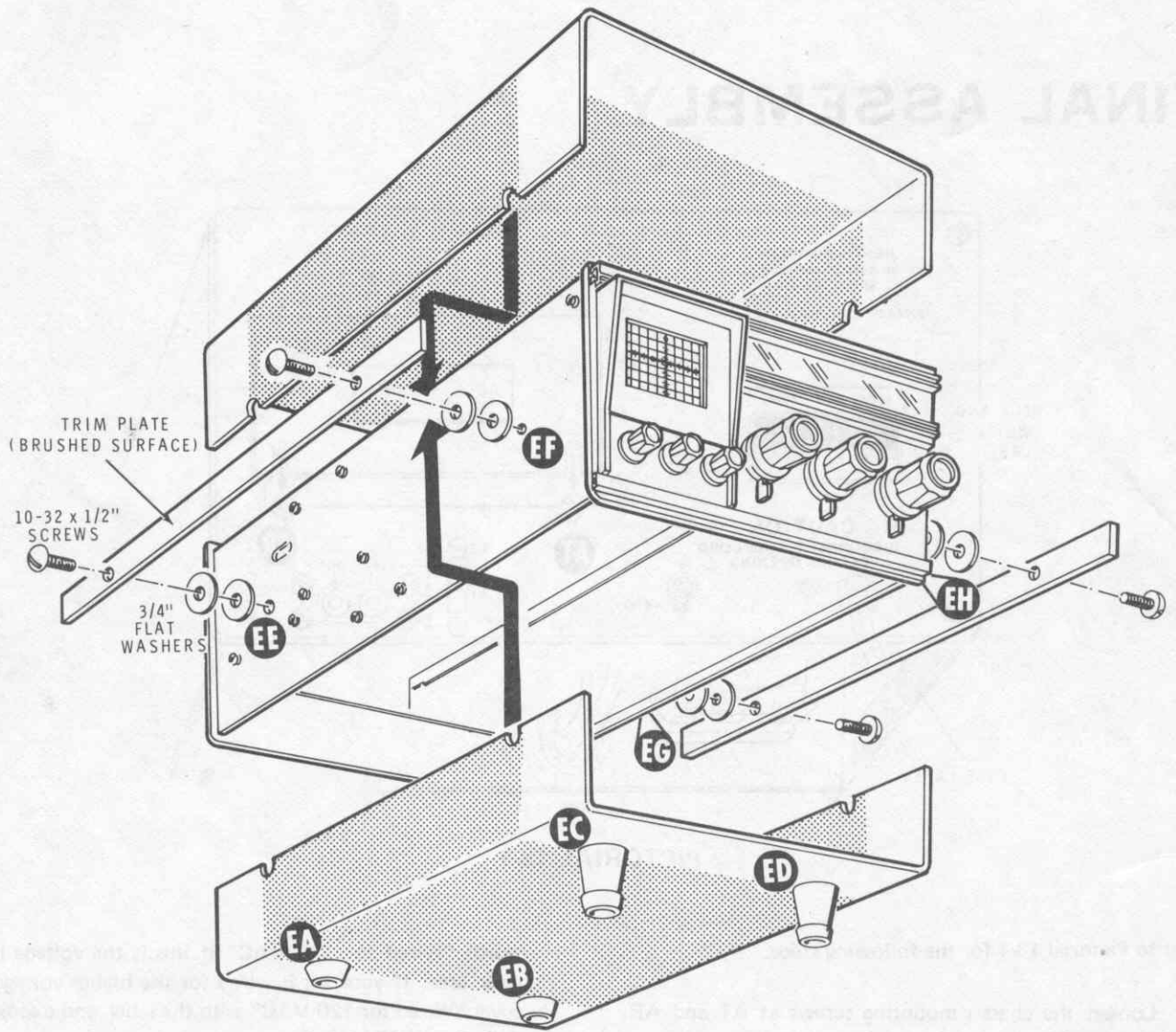

PICTORIAL 13-2

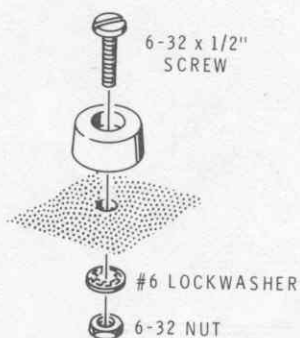

Detail 13-2A

Refer to Pictorial 13-2 for the following steps.

- () Refer to Detail 13-2A and mount a foot on the cabinet bottom at EA with 6-32 x 1/2" hardware.
- () In the same manner, mount another foot at EB.

NOTE: In the following two steps, if you do not want your Station Monitor to be tilted upward at the front, discard the two foot spacers and the 6-32 x 1-3/8" screws. Use the feet and the two extra 6-32 x 1/2" screws provided.

- () Refer to Detail 13-2B and mount a foot and a foot spacer at EC on the cabinet bottom. Use 6-32 x 1-3/8" hardware.
- () In the same manner, mount another foot and foot spacer at ED.

NOTE: In the following steps, the trim plates have a brushed surface and a plain surface. Be sure to position the plates so the brushed sides are out.

- () Place a 10-32 x 1/2" screw into one of the trim plate holes. Place two 3/4" flat washers on the end of the screw. Then start the screw into hole EE in the left side panel.

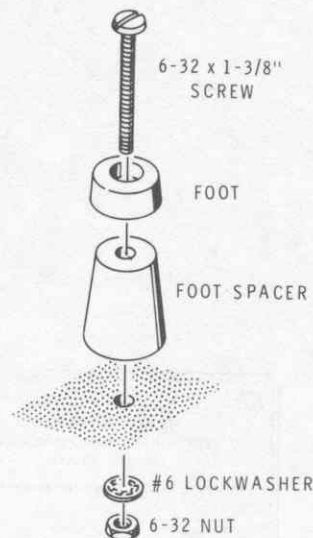

Detail 13-2B

- () In the same manner, start another 10-32 x 1/2" screw through the trim plate, through two flat washers, and into hole EF in the left side panel.
- () In the same manner, loosely mount the other trim plate on the right side panel with 10-32 x 1/2" screws and 3/4" flat washers at EG and EH.
- () Position the chassis assembly into the cabinet bottom as shown in the Pictorial. Be sure the flat washers at EE, EF, EG, and EH are inside the edges of the cabinet. Position the four trim plate bolts into the notches in the cabinet bottom.
- () Position the cabinet top down onto the cabinet bottom as shown and inside the top edges of the trim plates. After the front and rear of the cabinet sections are aligned, secure the four trim plate mounting screws.

This completes the assembly of your Station Monitor.

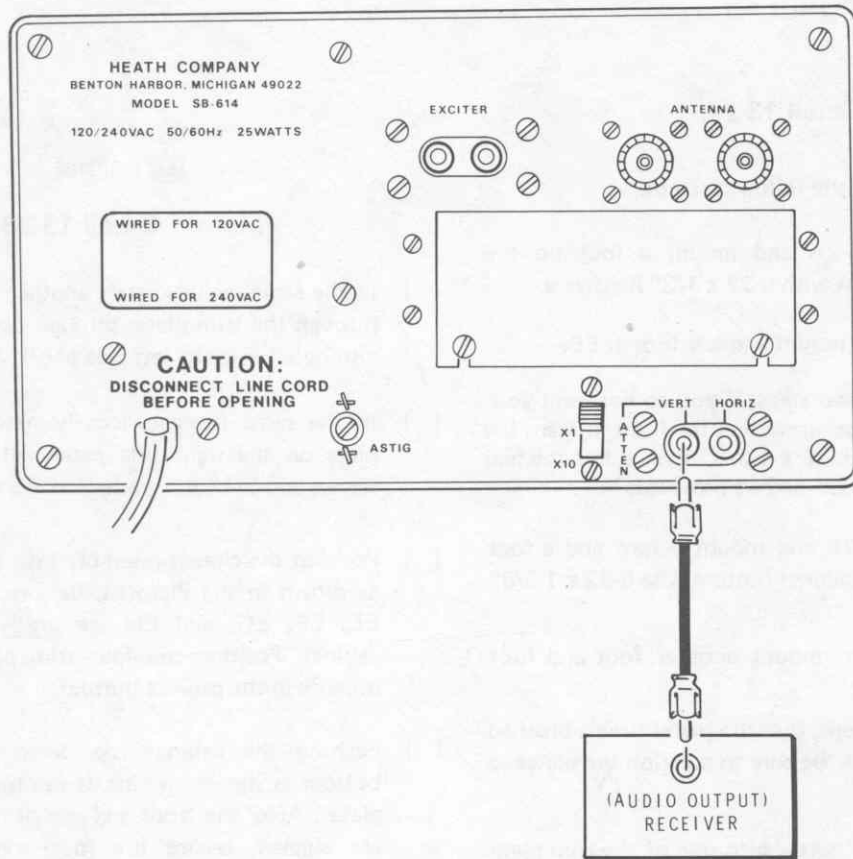

Figure 4-1

OPERATION

In addition to the following material, you will also find much information on the use of oscilloscope monitors for amateur purposes in recent editions of the "Radio Amateurs Handbook," published by the American Radio Relay League.

RECEIVER MONITORING (Figure 4-1)

Connect a pair of wires or a cable to the receiver speaker terminals as shown. Then connect these wires or the cable to the VERT phono jack of the Monitor.

Place the RANGE switch at the 100 Hz position and the SWEEP control at approximately the center of its rotation. Adjust the VERTICAL GAIN and HORIZONTAL GAIN controls to produce the desired patterns as shown on Page 77 under "Transmit Envelope Patterns."

When the receiver is adjusted for normal operation on an average signal, the VERTICAL GAIN control should be adjusted to produce a pattern 1/2" to 1" high.

NOTE: If negative clipping of the display is observed, too much receiver audio signal is coupled into the Monitor. Reduce the receiver audio gain, or place Monitor Atten switch SW3 in the X10 position.

Many of the transmitter patterns described later may also be observed as a received signal. Bear in mind the limitations described in the following paragraphs, and refer to the appropriate sample patterns for the type of signal received. (See Figure 4-2, fold-out from this page.)

The receiver can produce several distinct effects which can alter or reshape the incoming signal into a display quite different from that which was transmitted. The two most pronounced effects are produced by the presence of AVC, and by the narrow bandwidth employed in newer receivers.

With the AVC on, as you observe a pulsing signal such as CW or sideband, the leading portion of the waveform may be displayed with considerable higher than normal amplitude. This leading portion will reduce in height as the AVC takes hold. You can see this effect most easily by observing the difference between patterns 35 and 36 on Page 83.

You may note the same distortion when watching voice patterns that produce momentary flat-topping on sideband. This problem can be avoided if you turn off the receiver AVC and reduce the RF gain sufficiently to prevent overload.

The bandwidth of the receiver IF determines the ability of the Monitor to reproduce a display of the actual transmitted signal. Refer to the pattern sequence shown in Figure 4-2. In order to obtain an undistorted display, the IF bandwidth must be roughly 10 times the modulating frequency. For example, a 3 kHz bandwidth will pass a 300 Hz square wave without distorting it, but a 1000 Hz square wave would be shown as a somewhat distorted sine wave. Therefore, SSB signals that are "flat-topping" may appear acceptable on the RF envelope patterns.

You can most easily identify flat-topped signals by observing the lack of peaks and valleys in the pattern. See Figure 4-2. It is possible, however, that the signal may be deliberately "shaped" by premodulation clipping and filtering in the transmitter to produce a pattern that may appear somewhat flat-topped.

RECEIVER PATTERNS

SIGNAL AT XMTR

RECEIVER BANDWIDTH

3KC

6KC

16KC



1000 - tone
no flat topping.

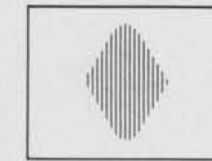

1000 -
severe flat topping



300 -
no flat topping

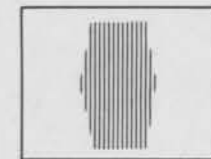

300 -
severe flat topping



SSB speech
(typical voice)
no flat topping

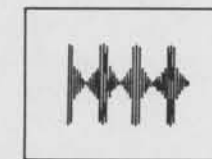

Note reduction of
sharp peaks on 3KC
bandwidth



severe flat topping



Note Valley does not go into base line.

Figure 4-2

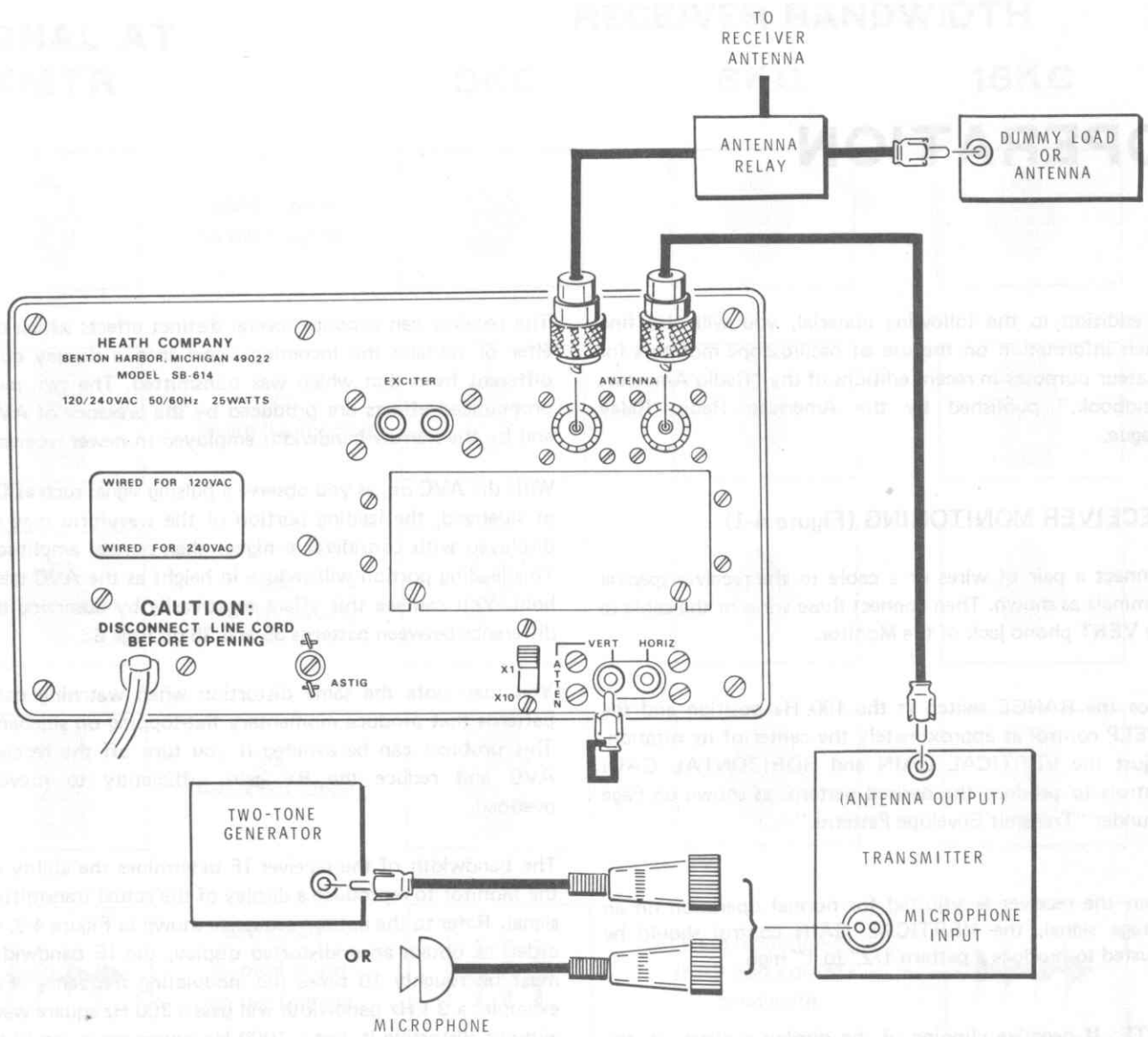

Figure 5-1

TRANSMITTER MONITORING (Figure 5-1)

Most transmitters have 50-75 Ω coaxial outputs. The following instructions are written for this type of connection with either a dummy load or an antenna. Make sure a dummy load or antenna is connected each time you operate the transmitter, either through the monitor as in the case of coaxial feed or directly where other antenna transmission line systems are used.

Refer to Figure 5-1 and connect the transmitter, the Station Monitor, and antenna or dummy load as follows:

NOTE: Avoid superimposed AC hum on the RF display by terminating the VERT input socket with the shorting plug, or by terminating the station receiver speaker. When you monitor audio signals from the receiver, the receiver audio must be muted during transmit intervals to avoid some superimposing of RF and audio signals.

1. Connect the RF output of the transmitter or linear amplifier to either ANTENNA jack on the rear of the Monitor.
2. Connect the dummy load or antenna to the other Monitor ANTENNA jack.
3. Set the front panel controls as described in the "Adjustments" section of the Manual on page 61. Set the VERTICAL GAIN control fully counterclockwise.
4. Turn on the transmitter and adjust the VERTICAL GAIN, HORIZONTAL GAIN, and SWEEP controls for the desired pattern height and display.
5. Check the modulation of an AM or SSB transmitter by connecting a two-tone generator to the microphone input of the transmitter. Check voice modulation by using a microphone to voice modulate the transmitter.
6. Refer to the "Transmit Envelope Patterns" on Page 77 to evaluate the transmitter display.

IMPORTANT: Always keep the amplitude of the display within the graticule (screened lines) by adjusting the VERTICAL GAIN control. Failure to keep the display amplitude within the graticule viewing area can cause toroid coil L201 and resistor R201 to overheat, and may result in damage to either of these parts. If the RF input to the Monitor approaches the 1000-watt limit, and if a steady CW or two-tone signal is being monitored, reduce the RF display to one-half the screen height and minimize the duration of the keyed signal. Normal keyed CW and SSB (voice modulated) signals may be displayed at full screen height for any period of time.



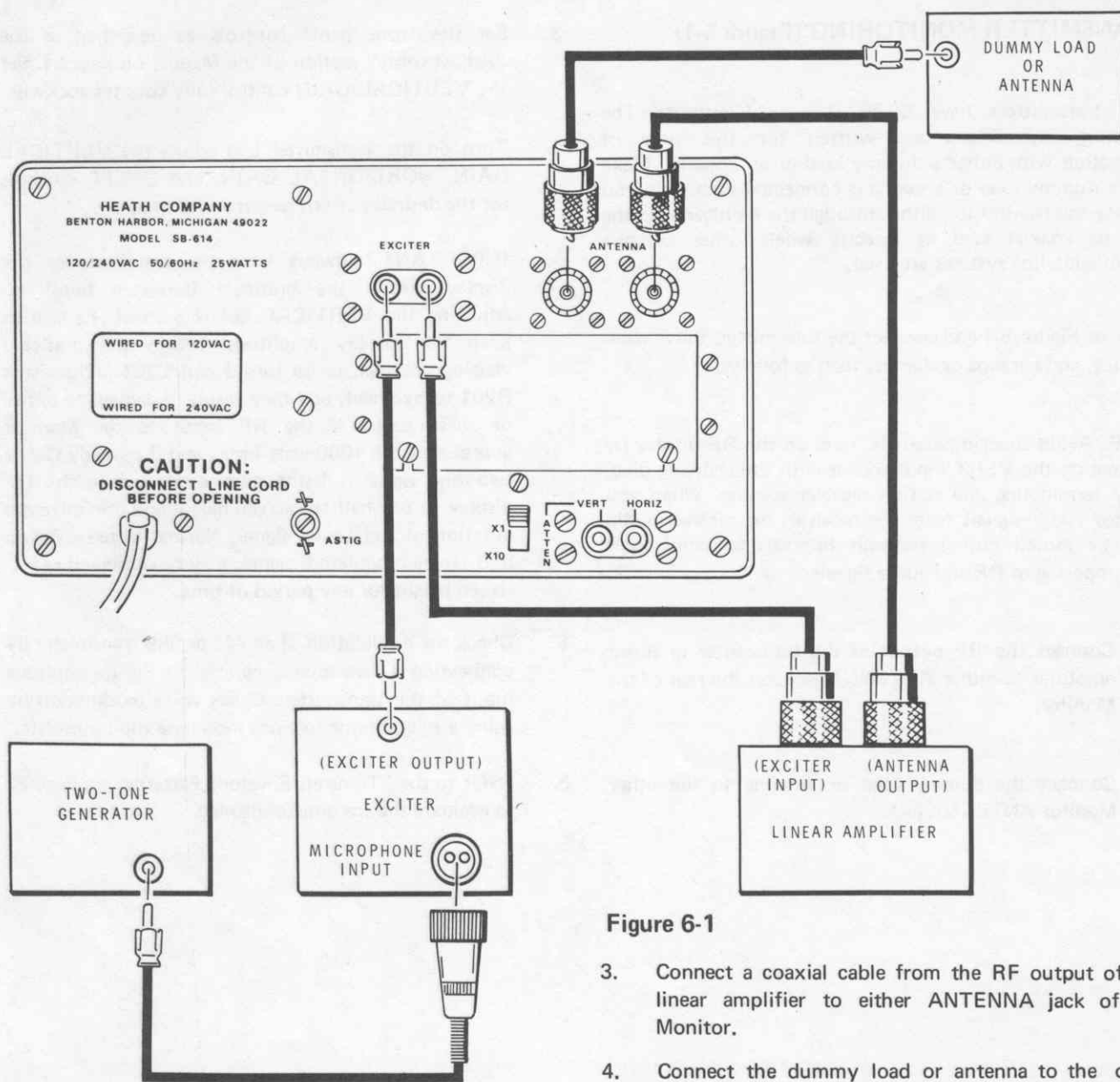
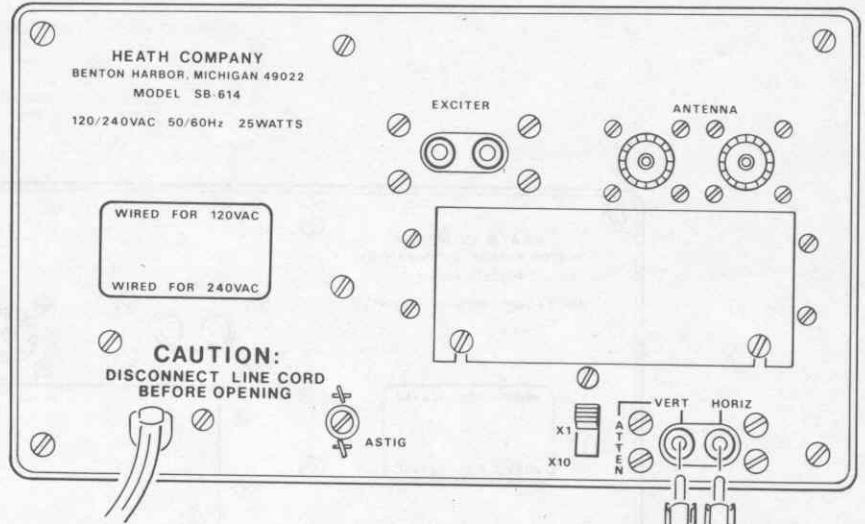

Figure 6-1

RF TRAPEZOID PATTERNS (Figure 6-1)

To check a linear amplifier for linearity, it is necessary to compare the exciter output with the RF output of the linear amplifier. The connections to be made for this purpose are shown in Figure 6-1.

1. Connect a coaxial cable from the RF output of the exciter to either EXCITER input jack of the Monitor.
2. Connect a coaxial cable from the other EXCITER jack on the Monitor to the input jack of the linear amplifier.
3. Connect a coaxial cable from the RF output of the linear amplifier to either ANTENNA jack of the Monitor.
4. Connect the dummy load or antenna to the other ANTENNA jack on the Monitor.
5. Connect a two-tone generator to the microphone input of the exciter.
6. Set all front panel controls on the Monitor as directed in the "Adjustments" section of the Manual on Page 61, but with the MODE switch in the TRAP position.
7. Turn on the exciter and linear amplifier and adjust the Monitor VERTICAL GAIN and HORIZONTAL GAIN controls, and the transmitter audio gain control, for the desired display height pattern. If the RF input to the Monitor approaches the 1000-watt limit, and if a steady CW or two-tone signal is being monitored, reduce the RF display to 1/2 the screen height and minimize the duration of the keyed signal.



8. The trapezoid pattern that is shown on the Monitor screen is obtained by comparing the RF output signal from the exciter with the amplified RF output of the linear amplifier. Refer to the "Trapezoid Pattern" on pages 80 and 81 for display analysis.

NOTE: The RF trapezoid pattern only indicates the linearity of the linear amplifier. This setup should not be used for general monitoring as it does not evaluate the exciter signal.

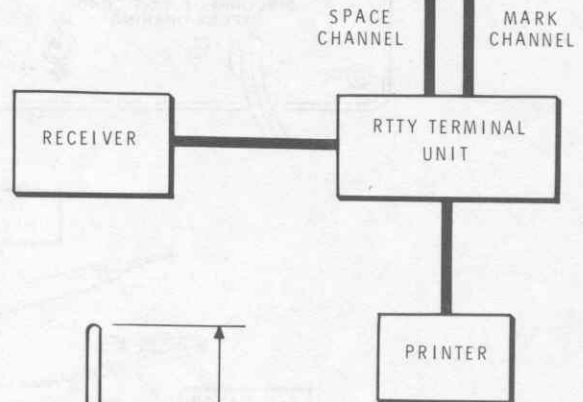

RTTY CROSS PATTERNS (Figure 7-1)

1. Connect a coaxial or shielded cable from the "mark" channel of the RTTY terminal unit to the HORIZ input jack of the Monitor.
2. Connect a coaxial or shielded cable from the "space" channel of the RTTY terminal unit to the VERT input jack of the Monitor.
3. Set the front panel controls as directed in the "Adjustments" section of the Manual on Page 61.
4. Turn the terminal unit and Monitor on, and place the Monitor MODE switch in the CROSS position.

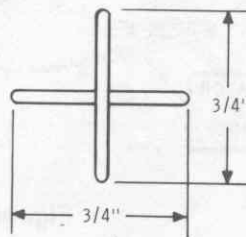

Figure 7-1

NOTE: The "mark" and "space" outputs of the terminal unit should be adjusted to provide equal output voltages from the two channels when properly tuned in. You can determine this by alternately inserting mark and space signals into the VERT input of the Monitor and adjusting the terminal unit's balance control for equal height from both channels.

5. With the space channel connected to the VERT input and the mark channel connected to the HORIZ input, adjust the VERTICAL and HORIZONTAL GAIN controls on the Monitor to produce a cross pattern with equal height and width (about 3/4" x 3/4"). Once the desired size of the cross pattern has been set, the gain controls on the Monitor should not be changed, as this will interact with the true setting of the balance control on the terminal unit.
6. Refer to the "RTTY Cross Patterns" on Page 82.

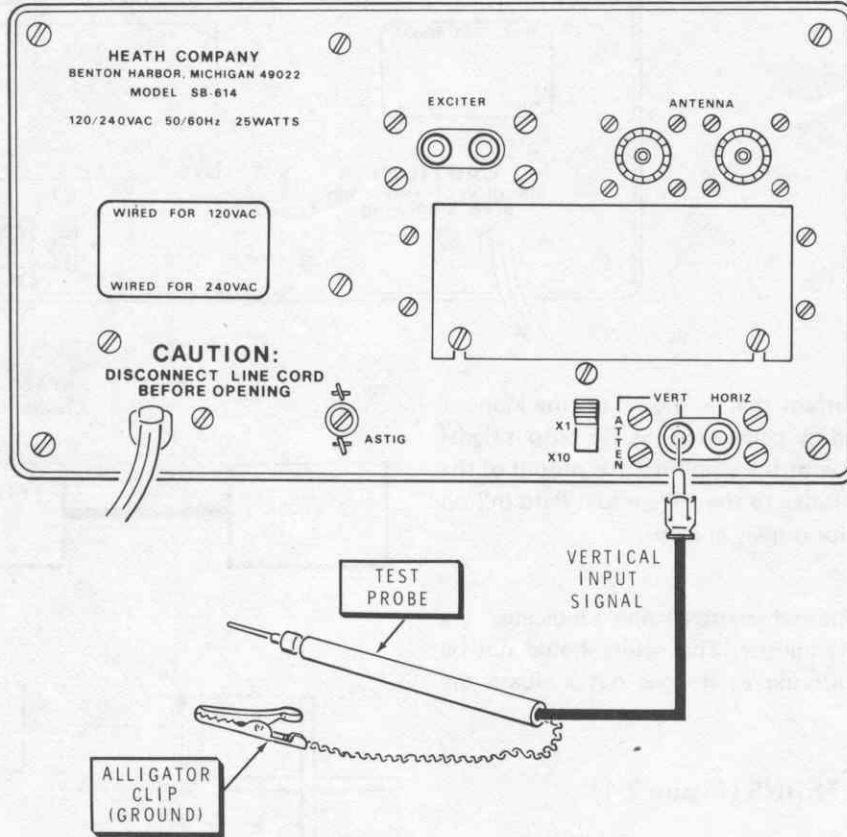

Figure 8-1

OSCILLOSCOPE USE (Figure 8-1)

The Station Monitor can be used as a normal oscilloscope for limited test applications where high sweep frequency or high vertical amplifier gain are not required.

For most applications, the MODE switch will be set at the SSB position to use the internal sawtooth generator for horizontal sweep. To use an external source for horizontal sweep, connect the horizontal signal to the HORIZ input, place the MODE switch at the CROSS position.

To use the Station Monitor as an oscilloscope, connect the leads and adjust the controls as follows.

1. Connect a test lead to the VERT input jack. Use a normal scope test probe.
2. Adjust the VERTICAL GAIN, HORIZONTAL GAIN, and SWEEP controls for the desired pattern.

NOTE: If negative clipping occurs, place the Atten switch in the X10 position.

TRANSMIT ENVELOPE PATTERNS

SSB signal, voice input, correctly adjusted.

①

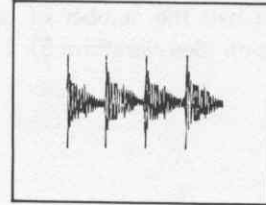

SSB signal, voice input, slightly excessive speech gain, or insufficient amplifier loading.

②

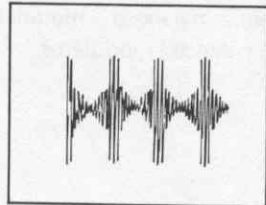

Pure CW carrier or perfect single tone input on SSB. May also occur on single tone SSB with excessive drive which results in amplifier "flat-topping." Note absence of fine ripple.

③

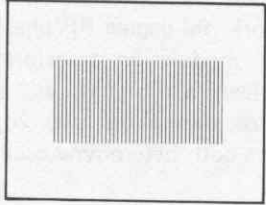

SSB signal, single tone input, sideband suppression down approximately 40 dB; or CW signal with spurious radiation down approximately 40 dB.

④

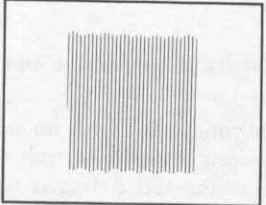

Same as 4 except down approximately 20 dB. In SSB, the poor suppression may be due to audio unbalance or improper RF phase shift. (Phasing system).

⑤

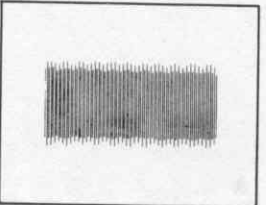

Same as 4, down approximately 10 dB.

⑥

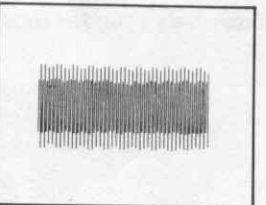

SSB signal, single tone input with carrier leakage. This pattern will have half the number of ripples due to poor sideband suppression (See waveform 5).

7



SSB signal, single tone input. Distortion in audio oscillator or audio system, balanced modulator detuned, or insufficient RF in balanced modulator.

8



SSB signal, single tone input. Very little sideband suppression. Caused by defective modulator stage, audio phase shift network, 90 degree RF phase shift component, partially shorted modulation transformer, secondary of transformer that feeds audio phase shift network shorted to ground, crystal oscillating on two adjacent frequencies simultaneously, or both heterodyne oscillators on together.

9

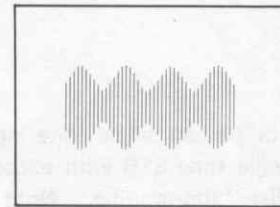

Normal double sideband, single tone input.

10

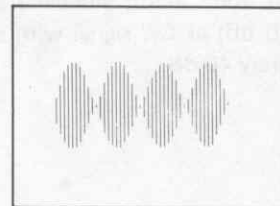

SSB signal, single tone input with no sideband suppression. May be due to one modulator stage dead, modulation transformer open or shorted, defective bandpass filter.

Normal SSB signal, 2-tone input, tones properly adjusted for equal amplitude.

11



SSB with carrier, single tone input. Incorrect value of carrier or modulation. Excessively rounded tops would indicate too much carrier.

Plate modulated AM, or double sideband with carrier inserted, single tone input. Nearly 100% modulated. Excellent waveform.

12

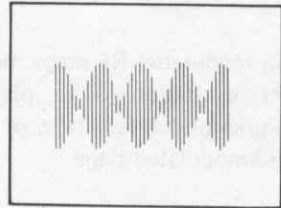

Double sideband with carrier inserted (low level AM), single tone input. Too much carrier inserted. Note that the positive peaks flatten before a fine base line is obtained. Peak flattening may also be caused by insufficient antenna loading, insufficient interstage loading, an overdriven linear amplifier, poor dynamic power supply regulation, etc.

13

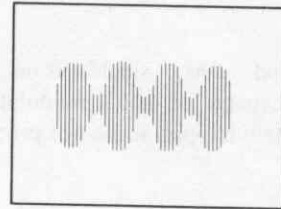

Double sideband with carrier inserted (low level AM), single tone input. Insufficient carrier insertion or excessive audio, resulting in high distortion (overmodulation). Also called Double Sideband Reduced Carrier (DSRC).

14



Low or high level AM with strong parasitics appearing on modulation peaks. Very fine, "grassy" appearance on peaks would indicate parasitics in the UHF range.

15

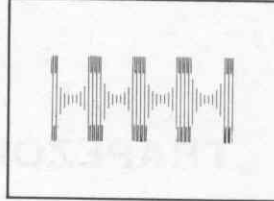

16

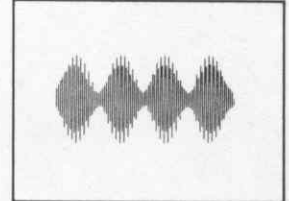

SSB, 2-tone input, or double sideband, single tone input. Carrier leakage in either causes uneven height of successive half cycles of modulation envelope.

17

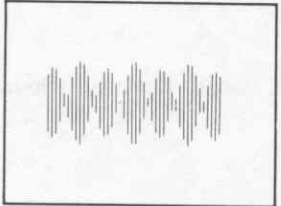

Low or high level AM, single tone input. Severe distortion in modulator system, or AF tone generator, RF feedback to audio system, or RF feedback to previous low level stage.

18

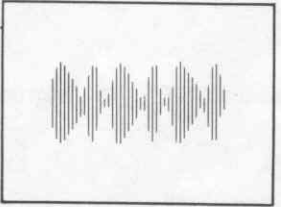

Nonlinearity in modulated RF stage, single tone input, due to insufficient excitation of a plate-modulated stage, overdrive to a grid-modulated stage, or insufficient antenna loading of a grid-modulated stage.

19

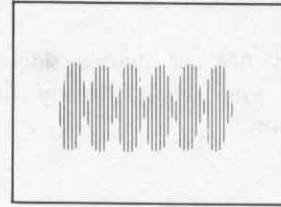

Plate-modulated AM, single tone input. Overdriven modulator incapable of 100% modulation. May also result from deliberately clipped audio not properly filtered.

20

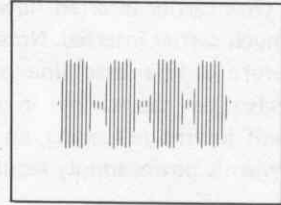
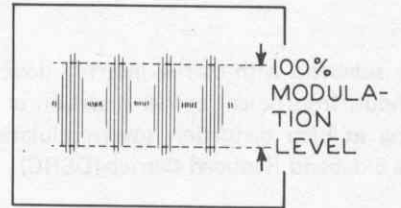

Plate-modulated AM, single tone input. Modulator output more than ample. Modulation in excess of 100% in both directions.

21



TRAPEZOID PATTERNS

RF trapezoid. Good linearity. Desirable pattern. 100% modulation.

22

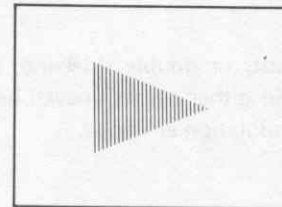

Modulation less than 100%. No distortion.

23

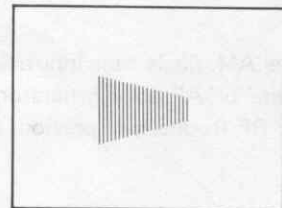

24

Nonlinear. Indicates overdrive, insufficient antenna loading, grid current curvature, or regeneration.

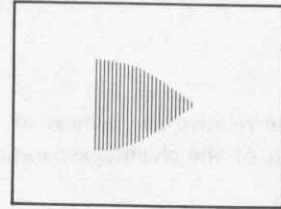

25

Nonlinear. In linear operation this also indicates regeneration or excessive grid bias.

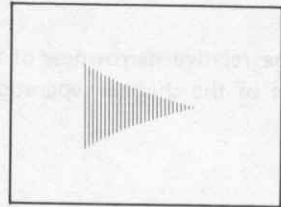

26

Parasitics occurring on modulation peaks.

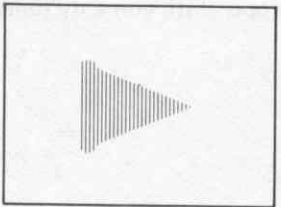

27

Grid modulation with improper neutralization and reactive load.

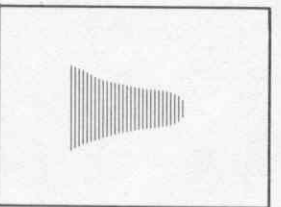

28

Unmodulated carrier. Can be caused by:

- No signal at horizontal deflection plates.
- Tone test oscillator inoperative.
- Gain control turned off on transmitter or oscilloscope.
- Audio failure in transmitter.

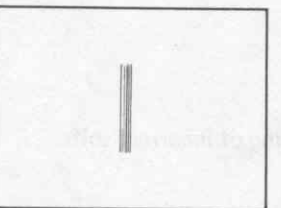

RTTY CROSS PATTERNS

Mark only. The relative narrowness of the ellipse provides good indication of the channel separation capability in the terminal unit.

29

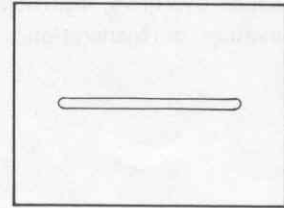

Space only. The relative narrowness of the ellipse provides good indication of the channel separation capability in the terminal unit.

30

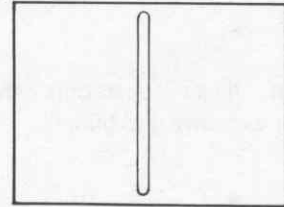

RTTY signal, proper shift, correctly tuned in.

31

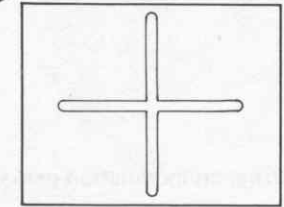

Incorrect shift, space tuned in, or selective fading.

32

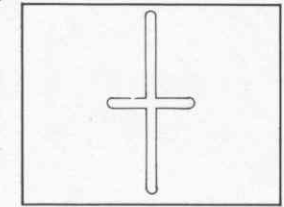

Incorrect shift, mark tuned in, or selective fading.

33

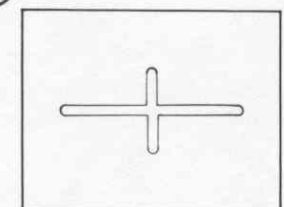

"Straddle" tuning of incorrect shift.

34

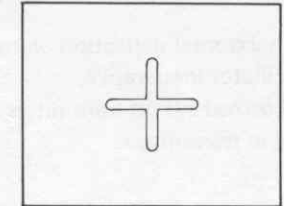

CW PATTERNS

Good CW pattern, properly shaped keying, string of dots.
Pattern can be synchronized using automatic keyer or bug.

CW pattern showing effect of receiver AVC action or poor power supply regulation in the transmitter.

CW pattern, mild key clicks.

CW pattern, severe key clicks.

CW pattern with considerable backwave, RTTY transmitter pattern with unequal mark and space outputs, or RTTY receiver pattern with signal not properly centered in IF bandpass, or bandpass too narrow.

CW pattern, string of dots indicating poor contacts or contact bounce in keying mechanism.

35

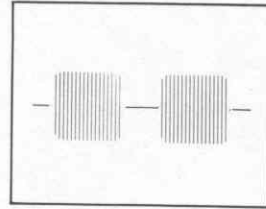

36

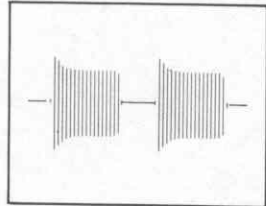

37

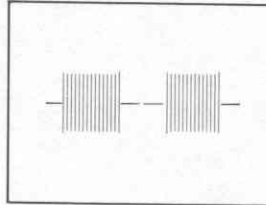

38

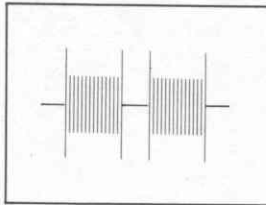

39

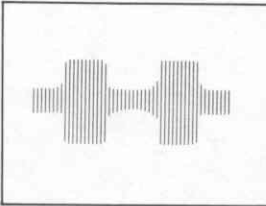

40

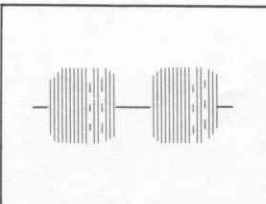

CW PATTERNS

30

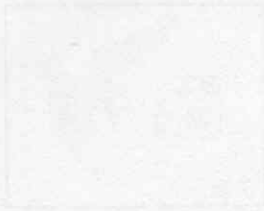

31



32



33



34



35



IN CASE OF DIFFICULTY

This section of the Manual is divided into three parts. The first part, titled "General Troubleshooting Information," describes what to do about difficulties that may occur right after the kit is assembled.

The second part, titled "Finding the Area of Trouble," describes a method for locating trouble in the differential amplifiers.

The third part, a "Troubleshooting Chart," is provided to help you if the general information does not clear up the problem, or if difficulties occur after the instrument has been in operation for some time. This chart lists a number of possible difficulties that could arise, and several possible causes.

Before you start any troubleshooting procedure, try to narrow the problem down to a specific area by trying the various functions of the Monitor.

GENERAL TROUBLESHOOTING INFORMATION

The following paragraphs deal with the types of difficulties that may show up right after a kit is assembled. These difficulties are most likely to be caused by assembly errors or faulty soldering. These checks will help you locate any error of this type that might have been made.

1. Recheck the wiring. Trace each lead in colored pencil on the Pictorial as it is checked. It is frequently helpful to have a friend check your work. Someone who is not familiar with the unit may notice something consistently overlooked by the kit builder.
2. About 90% of the kits that are returned for repair do not function properly due to poor connections and soldering. Therefore, you can eliminate many troubles by reheating all questionable connections to make sure that they are soldered as described in the "Kit Builders Guide."
3. Check to be sure that all transistors are in their proper locations. Make sure each transistor lead is connected to the proper point.
4. Check the values of the parts. Be sure that the proper part has been wired into the circuit as shown in the pictorial diagrams and called out in the wiring instructions.
5. Check for bits of solder, wire ends, or other foreign matter which may be lodged in the wiring. Check for solder bridges between circuit board foils. Compare your foil pattern against the "X-Ray Views" on Pages 99 and 100.

FINDING THE AREA OF TROUBLE

If a voltmeter is available, check the voltage readings against those shown on the Schematic diagram. NOTE: All voltage readings were taken with a high impedance input voltmeter. Voltages may vary as much as 20%. Also study the "Circuit Description" and "Block Diagram" so you will be better able to analyze and locate the trouble.

Because most of the circuits are DC coupled, it is almost impossible to list troubles in a "cause and effect" type of chart. For example, a saturated transistor on one side of a differential amplifier may appear as a trouble on the other side. However, a "Troubleshooting Chart" is provided to help you isolate the problem to a particular area of the Monitor.

Since the Position controls are at the front of the differential amplifiers and affect each succeeding stage, they serve as troubleshooting aids. When you are troubleshooting the vertical amplifier, for instance, first check the associated power supply voltages. Then check transistors Q104 and Q106. These voltages should vary as the Vertical Position control is turned. If these voltages change accordingly, the trouble may be in the CRT circuit. If the voltages do not change, the problem is either Q104 or Q106 or the preceding stages. Move the voltmeter to the preceding stage (Q103 and Q105) and repeat the procedure until you locate the trouble.

NOTE: In an extreme case where you are unable to resolve a difficulty, refer to the "Customer Service" information inside the rear cover of the Manual. Your Warranty is located inside the front cover.

Troubleshooting Chart

	CONDITION	POSSIBLE CAUSE
A.	Resistance from lug 1 of CRT to ground less than 3 M Ω .	<ol style="list-style-type: none"> 1. Diodes D105 or D106. 2. Capacitors C121 or C123. 3. Power transformer. 4. Focus or Intensity controls incorrectly wired. 5. Resistors R14 or R16.
B.	Resistance from junction of R148, R149, R151, and R152 to ground less than 100 k Ω .	<ol style="list-style-type: none"> 1. Diodes D104, D111, D112, or D113. 2. Zener diodes ZD101 or ZD102. 3. Transistors Q104, Q106, Q114, Q118, or Q121. 4. Capacitors C124 or C128. 5. Capacitors C19, C21, C201, or C202.
C.	Resistance from emitter (E) of Q122 to ground less than 150 Ω .	<ol style="list-style-type: none"> 1. Transistors Q102, Q109, Q112, Q113, or Q116. 2. Capacitor C15.
D.	Resistance from collector (C) of Q122 to ground less than 450 Ω .	<ol style="list-style-type: none"> 1. Diodes D107 or D108. 2. Zener diode ZD103. 3. Transistor Q122. 4. Capacitors C126 or C127.

CONDITION	POSSIBLE CAUSE
E. Indicator lamps and CRT filament do not light.	<ol style="list-style-type: none"> 1. Fuse. 2. Incorrectly wired fuseholder or transformer primary leads. 3. On-Off switch on Intensity control.
F. Indicator lamps do not light, but a spot or trace is seen on CRT.	<ol style="list-style-type: none"> 1. Resistor R13. 2. Indicator lamp terminal strip incorrectly wired. 3. Mode switch incorrectly wired.
G. CRT filament and indicator lamps light, but no trace or spot on CRT screen.	<ol style="list-style-type: none"> 1. No -1400 volt supply. 2. Incorrectly wired CRT socket. 3. Capacitors C107, C108, C112, or C114. 4. Incorrectly wired Position controls. 5. Transistors Q102, Q103, Q105, Q116, Q117, or Q119. 6. Mode switch.
H. Unable to center spot or trace on CRT screen.	<ol style="list-style-type: none"> 1. Mode switch in wrong position. 2. Check items G3 through G6, above. 3. RFC1, RFC2, RFC3, or RFC4. 4. Capacitors C19, C21, C201, or C202.
I. No horizontal trace deflection (Mode switch in SSB position).	<ol style="list-style-type: none"> 1. Mode switch incorrectly wired or defective. 2. Red, brown, or black shielded cables to Mode switch shorted or open. 3. Range switch incorrectly wired. 4. Sweep control incorrectly wired. 5. Transistors Q109, Q111, Q112, Q113, or Q115. 6. Diodes D103 or D104. 7. Capacitor C108. 8. No +9.0 or +180-volt power.
J. No horizontal trace deflection (Mode switch in Cross position.)	<ol style="list-style-type: none"> 1. No signal at Horiz input jack. 2. White shielded cable open or shorted. 3. Horiz input jack incorrectly wired.

	CONDITION	POSSIBLE CAUSE
K.	No vertical deflection (Mode switch in SSB position).	<ol style="list-style-type: none"> 1. No signal at Vert input jack. 2. Low input level, Atten switch in X10 position. 3. Vert input or Atten switch incorrectly wired. 4. Blue shielded cable at Atten switch open or shorted. 5. Yellow shielded cable at Vertical Gain control shorted. 6. Diodes D101 or D102. 7. Transistors Q101 through Q106. 8. Vertical Gain control. 9. Check items H3, H4, and I8, above.
L.	Poor focus of trace or spot on CRT screen.	<ol style="list-style-type: none"> 1. Paper backing not removed from graticule. 2. Astig control incorrectly wired. 3. CRT socket incorrectly wired. 4. Focus control incorrectly wired. 5. Resistors R14, R16, or R154. 6. Low -1400 volts from power supply. 7. CRT.
M.	Trace will not disappear when Intensity control is turned CCW.	<ol style="list-style-type: none"> 1. Transistor Q114. 2. Capacitor C111. 3. Resistors R125, R126, or R153.
N.	Audio signal waveforms distorted.	<ol style="list-style-type: none"> 1. Distorted audio input signal. 2. Input signal too strong, Atten switch in X1 position. 3. Check items K3, K6, K7, K8, and K9, above.
P.	Poor synchronization.	<ol style="list-style-type: none"> 1. Diode D201. 2. Orange shielded cable. 3. Transistors Q107 through Q111.
Q.	RF waveforms distorted.	<ol style="list-style-type: none"> 1. Distorted input signal. 2. Diode D201. 3. Coil L201. 4. Capacitors C201 or C202. 5. Redress leads around CRT (See Pictorials 9-2 and 9-3 on Page 52.) 6. RF input frequency too high (above 54 MHz).

	CONDITION	POSSIBLE CAUSE
R.	Unable to obtain trapezoid pattern on CRT (Mode switch in Trap position. No spot, no trace).	<ol style="list-style-type: none"> 1. Diodes D202 or D203. 2. Transistor Q201. 3. Zener diode ZD201. 4. Capacitors C205 or C206.
S.	Spot will not clamp to right side of screen (Trap position).	<ol style="list-style-type: none"> 1. Gray shielded cable open. 2. Transistors Q101 or Q201. 3. Readjust Horizontal Pos control. 4. Mode switch incorrectly wired (brown wire).
T.	Trapezoid pattern distorted or is only vertical trace.	<ol style="list-style-type: none"> 1. Exciter and linear amplifier incorrectly connected to Monitor (see Figure 6-1 on Page 74). 2. Diode D204. 3. Violet shielded cable. 4. Capacitors C207 or C208. 5. Resistor R207. 6. Recheck Q1 through Q6, above.
U.	RF vertical display not high enough, or too high, for input level. Display behaves erratically when Vertical Gain control is turned.	<ol style="list-style-type: none"> 1. Atten switch and associated capacitors incorrectly wired or installed. (See Detail 10-1B and Pictorial 10-2 on Page 55.)
V.	SSB indicator lamp stays on regardless of switch setting.	<ol style="list-style-type: none"> 1. Diode D1.
W.	Low -1400-volt supply.	<ol style="list-style-type: none"> 1. Check items A1 through A5.
X.	+180-volt supply too high or too low.	<ol style="list-style-type: none"> 1. Check items B1 through B5.
Y.	+9.0-volt supply too high or too low.	<ol style="list-style-type: none"> 1. Check items C1 and C2. 2. Check items D1 through D4.

POSSIBLE CAUSE	CORRECTIVE ACTION
1. Loose connections 2. Defective components 3. Faulty wiring 4. Improper assembly	1. Check all connections 2. Replace defective components 3. Check wiring 4. Reassemble properly
1. Incorrect component values 2. Faulty components 3. Poor soldering technique 4. Defective components 5. Improper assembly	1. Check component values 2. Replace faulty components 3. Improve soldering technique 4. Replace defective components 5. Reassemble properly
1. Loose connections 2. Defective components 3. Faulty wiring 4. Improper assembly	1. Check all connections 2. Replace defective components 3. Check wiring 4. Reassemble properly
1. Loose connections 2. Defective components 3. Faulty wiring 4. Improper assembly	1. Check all connections 2. Replace defective components 3. Check wiring 4. Reassemble properly
1. Loose connections 2. Defective components 3. Faulty wiring 4. Improper assembly	1. Check all connections 2. Replace defective components 3. Check wiring 4. Reassemble properly
1. Loose connections 2. Defective components 3. Faulty wiring 4. Improper assembly	1. Check all connections 2. Replace defective components 3. Check wiring 4. Reassemble properly
1. Loose connections 2. Defective components 3. Faulty wiring 4. Improper assembly	1. Check all connections 2. Replace defective components 3. Check wiring 4. Reassemble properly

SPECIFICATIONS

RF SAMPLING SECTION

Frequency Coverage	80 through 6 meters (3.5 - 54 MHz).
Sensitivity	1/4" vertical deflection at 10 watts. 3/4" vertical deflection at 100 watts.
RF Power Limits	
Exciter Input (50-75 Ω)	10 to 300 watts.
Antenna Input (50-75 Ω)	10 to 1000 watts.
Insertion Loss	Negligible.

VERTICAL AMPLIFIER

Input Impedance	1 M Ω shunted by 75 pF.
Sensitivity	60 millivolts/1/4" vertical deflection.
Attenuator	2-position: X1: 1 volt rms maximum, X2: 10 volts rms maximum.
Frequency Response	10 Hz to 50 kHz typical.

HORIZONTAL AMPLIFIER

Input Impedance	1 M Ω .
Sensitivity	60 millivolts rms/1/4" horizontal deflection.
Frequency Response	10 Hz to 3 MHz typical.

CIRCUIT DESCRIPTION

Refer to the Schematic diagram (fold-out from Page 103) and the Block Diagram (fold-out from Page 92) while reading this Circuit Description.

To help you locate specific parts in the Station Monitor or on the Schematic, the resistors, capacitors, transistors, and diodes are numbered in the following groups.

1-99	Parts mounted on the chassis.
100-199	Parts mounted on the main circuit board.
200-299	Parts mounted on the demodulator circuit board.

VERTICAL AMPLIFIER

A signal applied to the Vert input jack is coupled through the frequency-compensated attenuator network. Capacitor C12 blocks any DC from the attenuator circuits. From the attenuator circuit, a portion of the input signal is coupled through resistor R107 and capacitor C101 to the gate of transistor Q101. Resistor R107 protects Q101 from being damaged in case a high potential is applied to the input jack while vertical Atten switch SW3 is in the X1 position. Diodes D101 and D102 are transistors connected to provide a zener action. These diodes limit the input signal to approximately ± 9 volts, which further protect Q101 from excess gate voltage. Capacitor C101 improves high frequency response by forming a high frequency path around R107.

Transistor Q101 is a field effect transistor (FET) connected as a source follower. This type of transistor provides the high impedance input necessary to prevent loading of the signal source.

The signal is AC-coupled through capacitor C107 and applied across Vertical Gain control R9. A portion of this signal is directly applied to the gate of source follower Q102. Since the following stages are DC coupled, capacitor C107 DC-isolates Q101 from Q102. This prevents any trace shift due to varying signal levels.

The output from source follower transistor Q102 is amplified by transistor Q103. A portion of the signal applied to the base of Q103 appears at its emitter. Because transistors Q103 and Q105 have a common emitter resistance, the signal present at the Q103 emitter is effectively coupled to the emitter of Q105.

Transistor Q105 functions as a common base amplifier whose base is held constant by Vertical Pos control R7. This control positions the trace by applying a DC voltage to the base of transistor Q105, causing a DC unbalance in the vertical amplifier. When the collector output voltage of Q103 decreases, its emitter voltage will increase. An increased emitter voltage at Q105 reduces its forward bias and increases its collector output voltage. The signal at the collector of transistor Q105 reduces its forward bias and increases its collector output voltage. The signal at the collector of transistor Q105 is 180 degrees out of phase with the signal at the collector of Q103, forming a "push-pull" type of amplifier required to drive the CRT deflection plates. Capacitor C113 is an emitter bypass capacitor to boost the gain at high frequencies. Emitter resistors R131 and R132, with Vert Bal control R128, establish the DC gain of the vertical amplifier.

Output amplifiers Q104 and Q106 again amplify the differential signal and drive the vertical plates of the CRT.

SWEEP GENERATOR

Capacitor C203 couples a portion of the vertical input audio signal to the base of transistor Q107 through resistor R202 and diode D201, a shaping network. Diode D201 also demodulates any AM or SSB RF signal applied to the RF sampling circuit.

The preshaped sync signal is applied to a Schmitt trigger circuit, Q107 and Q108, a regenerative bistable circuit which produces a rectangular pulse output each time it is triggered and reset.

Transistors Q111 and Q112 form an astable multivibrator. When transistor Q112 is conducting and Q111 is cut off, one or more of the timing capacitors (C15 through C17) are charged through transistor Q112. As the voltage at the emitter of Q112 approaches the voltage at the base, as a result of charging the capacitor, Q112 will cut off and drive Q111 into conduction. The charged timing capacitor will now discharge through the constant current source circuit of Q113. The setting of Sweep control R12 determines the current flowing through Q113, which, in turn, determines the discharge current (and discharge time) of the timing capacitor. As the timing capacitor discharges, a positive-going ramp voltage (sawtooth) is generated and coupled to the horizontal amplifier. The frequency of the horizontal sweep is determined by the particular timing capacitor selected by Range switch SW4 and the discharge current.

Since transistors Q109 and Q111 have a common emitter resistor (R117), a signal applied to the base of Q109 is emitter coupled to transistor Q111. Thus, the pulse output (sync signal) of the Schmitt trigger, Q108, is coupled to Q111. This causes Q111 to turn on and Q112 to cut off and start the sweep just prior to the time it would normally begin.

When the signal at the emitter of Q109 goes positive, a positive pulse is coupled through capacitor C111 to the base of blanking amplifier Q114.

A negative-going output pulse is coupled through capacitor C119 to the grid of the CRT. This pulse turns off the electron beam during retrace, preventing the retrace from appearing on the CRT.

RF SAMPLING CIRCUIT

Transmitted RF signals as high as 1000 watts (PEP) may be viewed on the Station Monitor when these signals are properly terminated in a 50 or 75 ohm transmission line or dummy load. The transmitting antenna feedline is coupled through the Antenna jacks on the rear panel of the Monitor. A portion of the RF signal is sampled from the feedline and coupled through capacitor C1 to RF attenuator switch SW1, which can be reduced in 11 step intervals. Capacitors C2 through C11 are connected in series in descending value on the switch. Attenuator switch SW1 has no stepping detent, and is mechanically coupled to Vertical Gain control R9.

From the RF attenuator switch, the RF signal is coupled to toroid coil L201, a bifilar-wound coil on a toroid core. It is connected as an unbalanced-to-balanced balun. The balanced output of coil L201 couples the RF signal through DC blocking capacitors C201 and C202 to the vertical deflection plates of the CRT. Resistor R201 broadens the frequency response of the balun.

RF chokes RFC1 through RFC4 offer high impedance to the RF signals on the vertical deflection lines to prevent the RF sample signals from affecting the vertical deflection amplifier circuits of Q104 and Q106.

HORIZONTAL DEFLECTION

Mode switch SW2 has three positions which determine the type of signal that will be used for horizontal deflection in the CRT. When the Mode switch is in the SSB position, the sawtooth signal from the sweep generator is coupled from the collector of transistor Q113 to the gate of transistor Q115. The operation of the horizontal amplifier is identical to that of the vertical amplifier. The positive-going sawtooth voltage is amplified and applied to the horizontal deflection plates of the CRT. This increasing voltage causes the electron beam to sweep across the face of the CRT, producing a visible trace.

When Mode switch SW2 is in the Trap position, a signal from the Exciter input jack is rectified by RF demodulator diode D204. This rectified RF voltage is coupled through capacitor C208 to the gate of transistor Q115. When a modulated RF signal is applied directly to the vertical deflection plates of the CRT and the modulating audio signal is applied to the horizontal deflection plates, a trapezoidal pattern is presented on the screen of the CRT. Resistors R2 and R206 form an RF voltage divider network so the voltage limitation of diode D204 is not exceeded. RF filtering is accomplished through resistor R207 and capacitor C207.

In the Cross mode of operation, any appropriate signal applied to the Horiz input jack is coupled through capacitor C18 and the contacts of Mode switch SW2 to the gate of transistor Q115.

CLAMPER CIRCUIT

In the Trap mode of operation, when no RF signal is present at the Monitor input jacks, the trace is reduced to a small spot. Since the small spot could burn a hole in the CRT phosphor coating, a clamp voltage is generated to prevent this. A supply voltage, coupled to transistor Q201, causes Q201 to conduct. Resistor R112, in the base bias network to transistor Q119, also becomes the drain load for transistor Q201, causing it to conduct. Since Q201 is in parallel with the Horizontal Pos control, the base bias on Q119 is reduced. This unbalances the horizontal amplifier transistors, thus moving the spot off the right side of the CRT screen.

When an RF signal is applied to the Antenna jacks, a small portion of the signal is coupled through capacitor C204 from voltage divider network R1 and R203 to the negative voltage doubler circuit consisting of diodes D202 and D203 to produce a negative bias. This negative DC voltage is applied to the gate of Q201, causing the transistor to stop conducting which, in turn, causes the drain voltage and the base bias of Q119 to return to normal. This causes the trace to return to the center of the CRT screen.

Capacitor C205 and resistor R204 form the filter network. Capacitor C206 is a timing capacitor which holds a slight charge to keep transistor Q201 cut off. This causes a slight time delay to momentarily hold the spot on the screen. Thus, the display remains visible and is kept from jumping to the edge of the display area during normal voice modulation. The gate of the transistor is protected by the zener action of diode ZD201.

With the Mode switch in the Trap position, the gate of transistor Q102 is shorted to chassis ground. Shorting this gate avoids any "blooming" of the spot when the spot is clamped to the right of the display area.

POWER SUPPLY

Line voltage is connected through the slow-blow fuse and On-Off switch SW5 (on the Intensity control) to the primary windings of the power transformer. The dual-primary windings may be connected in parallel for 120-volt operation or in series for 240-volt operation.

A high voltage secondary winding of the power transformer is connected to the voltage doubler circuit consisting of diodes D105 and D106 and capacitors C122 and C123. Capacitor C121 filters this negative high voltage which is fed through resistor R154 to the grid of the CRT. The intensity and focusing voltages are also supplied to the CRT from the voltage divider network consisting of resistors R14 through R17. A separate 6.3-volt winding supplies the CRT filament voltage.

A low voltage secondary winding is connected to the voltage doubler circuit consisting of diodes D107 and D108 and capacitors C129 and C131. Zener diode ZD103 and resistor R157 maintain a constant voltage to the base of pass transistor Q122. The output voltage is regulated at +9.0 volts DC by series pass transistor Q122 and zener diode ZD103. Capacitors C126 and C127 filter the rectified voltage and capacitor C125 prevents the pass transistor from oscillating in case of load loss.

Another secondary winding is connected to a full-wave bridge rectifier consisting of diodes D109 through D113. Capacitors C128 and C124 filter the rectified voltage. Zener diodes ZD101 and ZD102, and resistors R155 and R156, provide a regulated +180 volts DC output.

CHASSIS PHOTOGRAPHS

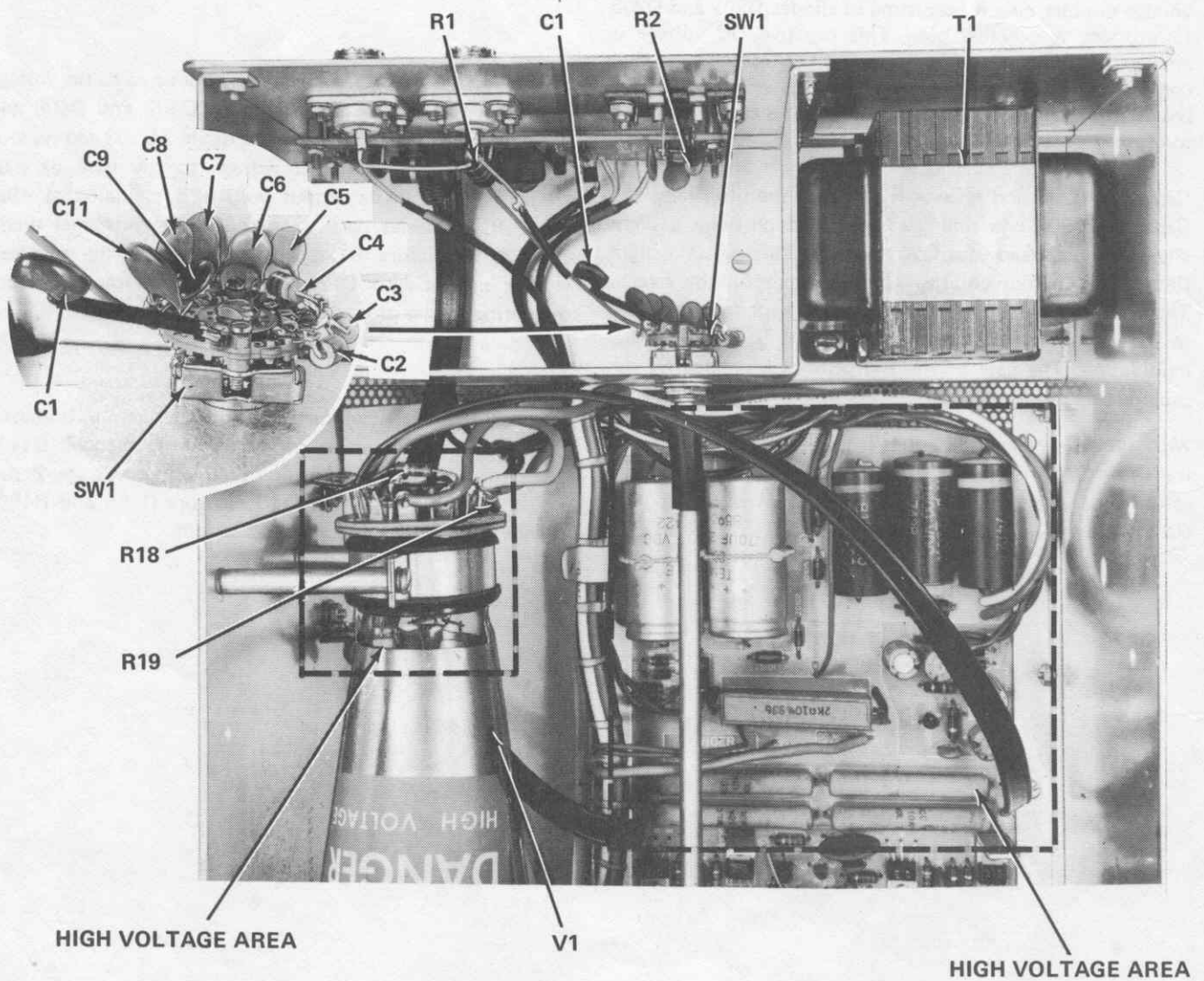

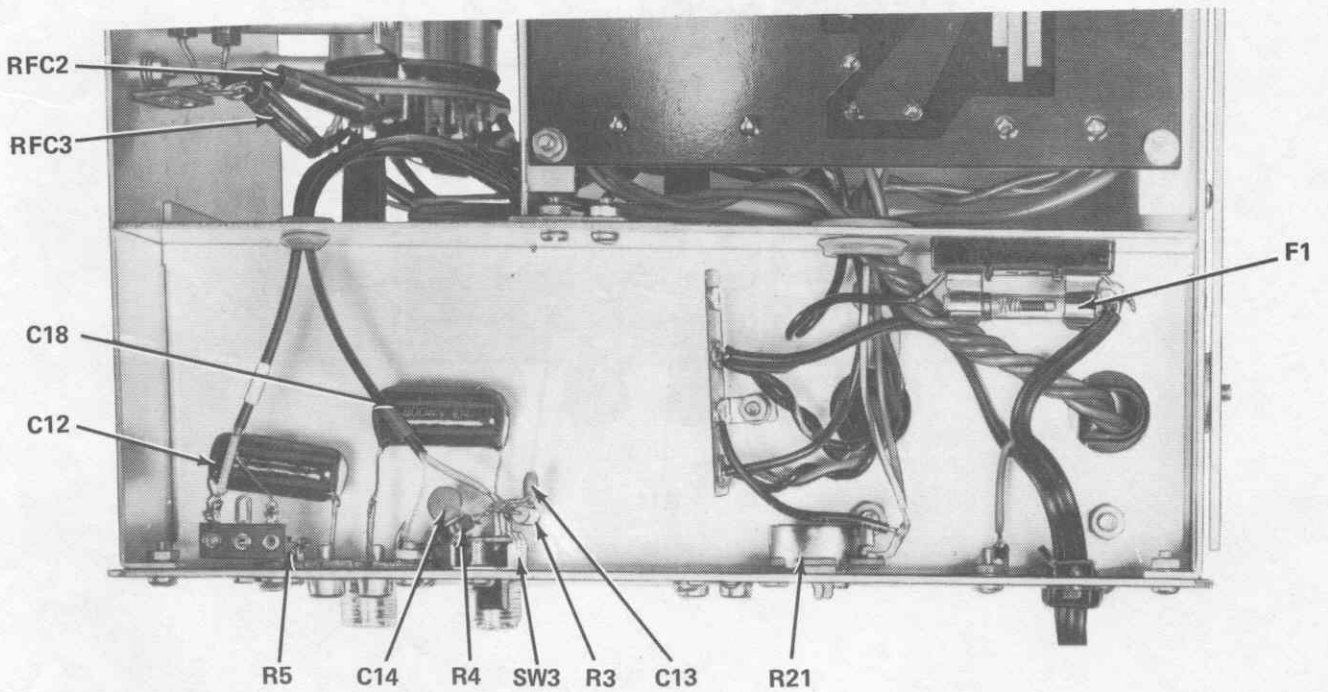
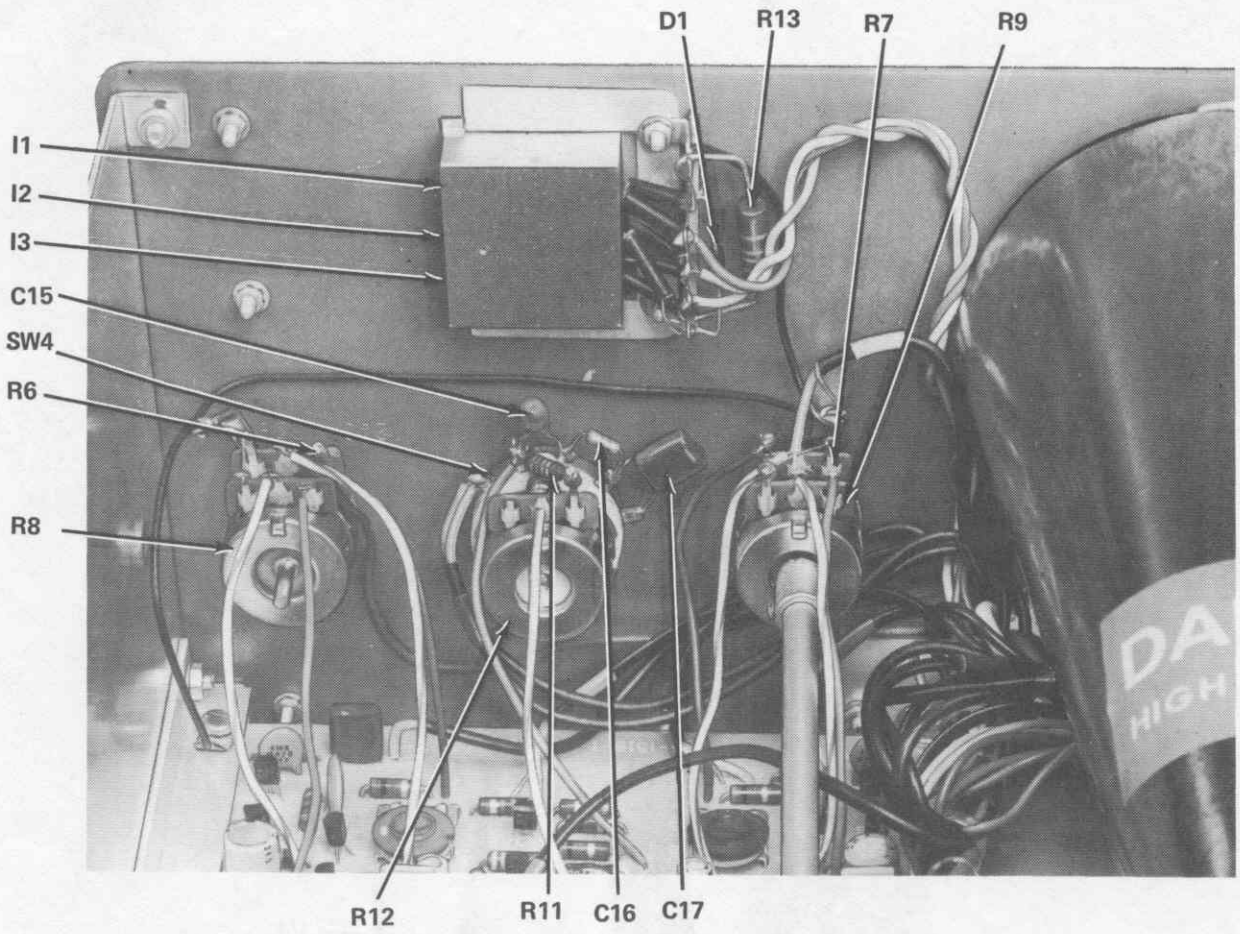

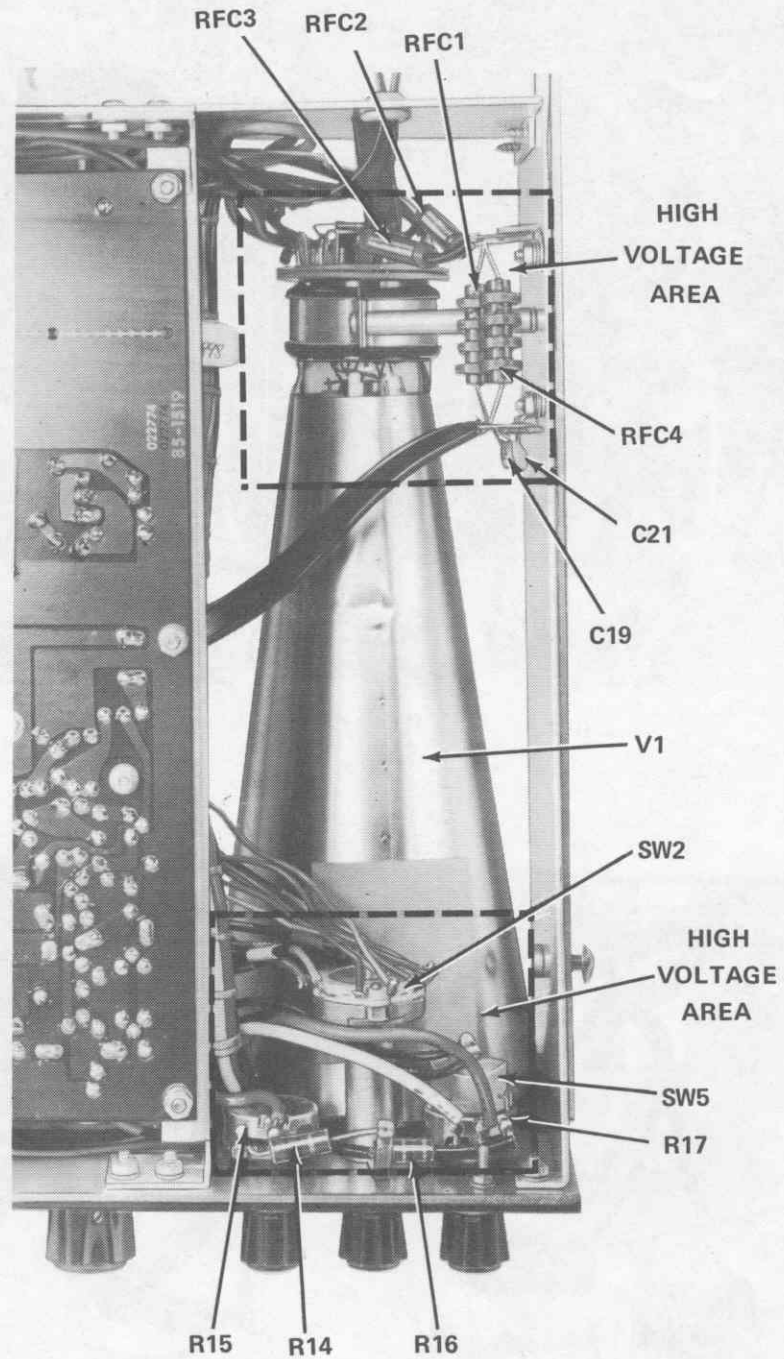

CIRCUIT BOARD X-RAY VIEWS

NOTE: To find the PART NUMBER of a component for the purpose of ordering a replacement part:

- A. Find the circuit component number (R5, C3, etc.) on the "X-Ray View" or "Chassis Photograph."
- B. Locate this same number in the "Circuit Component Number" column of the "Parts List" in the front of this Manual.
- C. Adjacent to the circuit component number, you will find the PART NUMBER and DESCRIPTION which must be supplied when you order a replacement part.

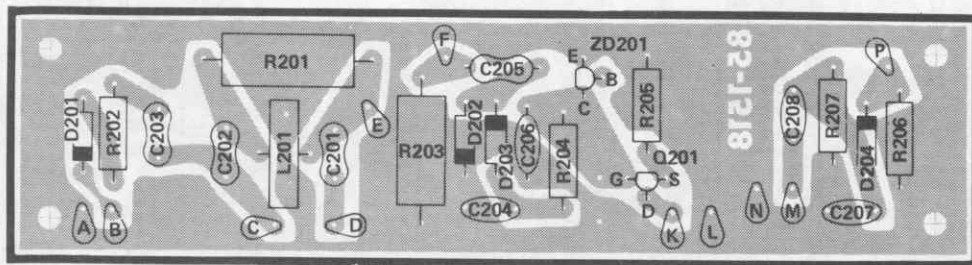

DEMODULATOR CIRCUIT BOARD
(SHOWN FROM COMPONENT SIDE)

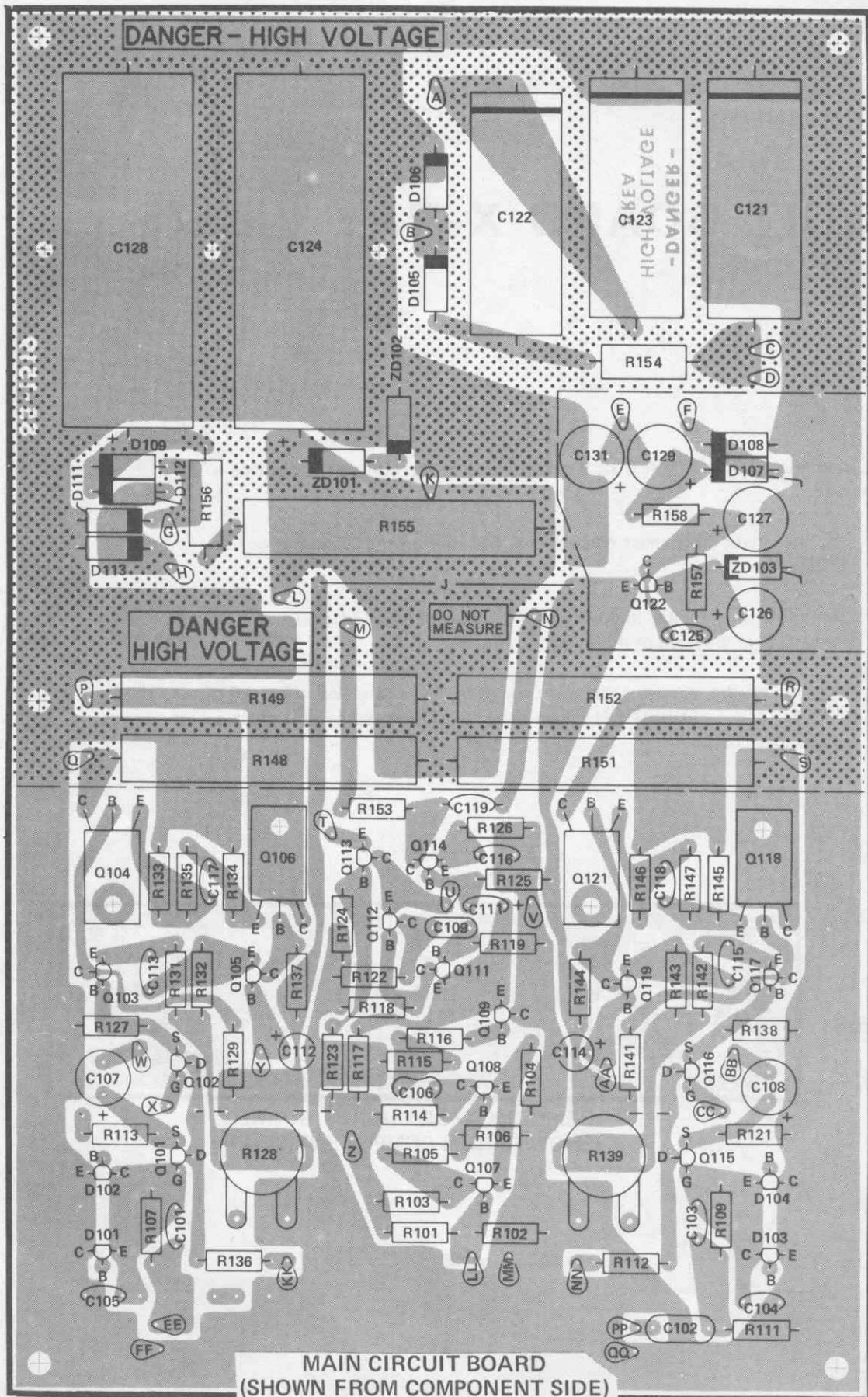

CIRCUIT BOARD VOLTAGE CHARTS

NOTES:

1. Voltages taken from the point indicated to chassis ground with a high impedance input voltmeter.
2. Voltage readings may vary $\pm 20\%$.
3. Refer to the Schematic Diagram Notes for settings of switches and controls, and for voltage symbols.
4. *This voltage may vary from 0 to -9 VDC (maximum), depending on the level of RF at the antenna input jacks.

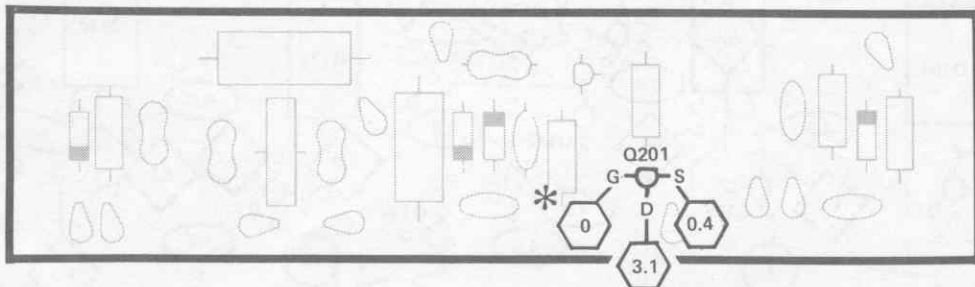

DEMODULATOR CIRCUIT BOARD
(SHOWN FROM COMPONENT SIDE)

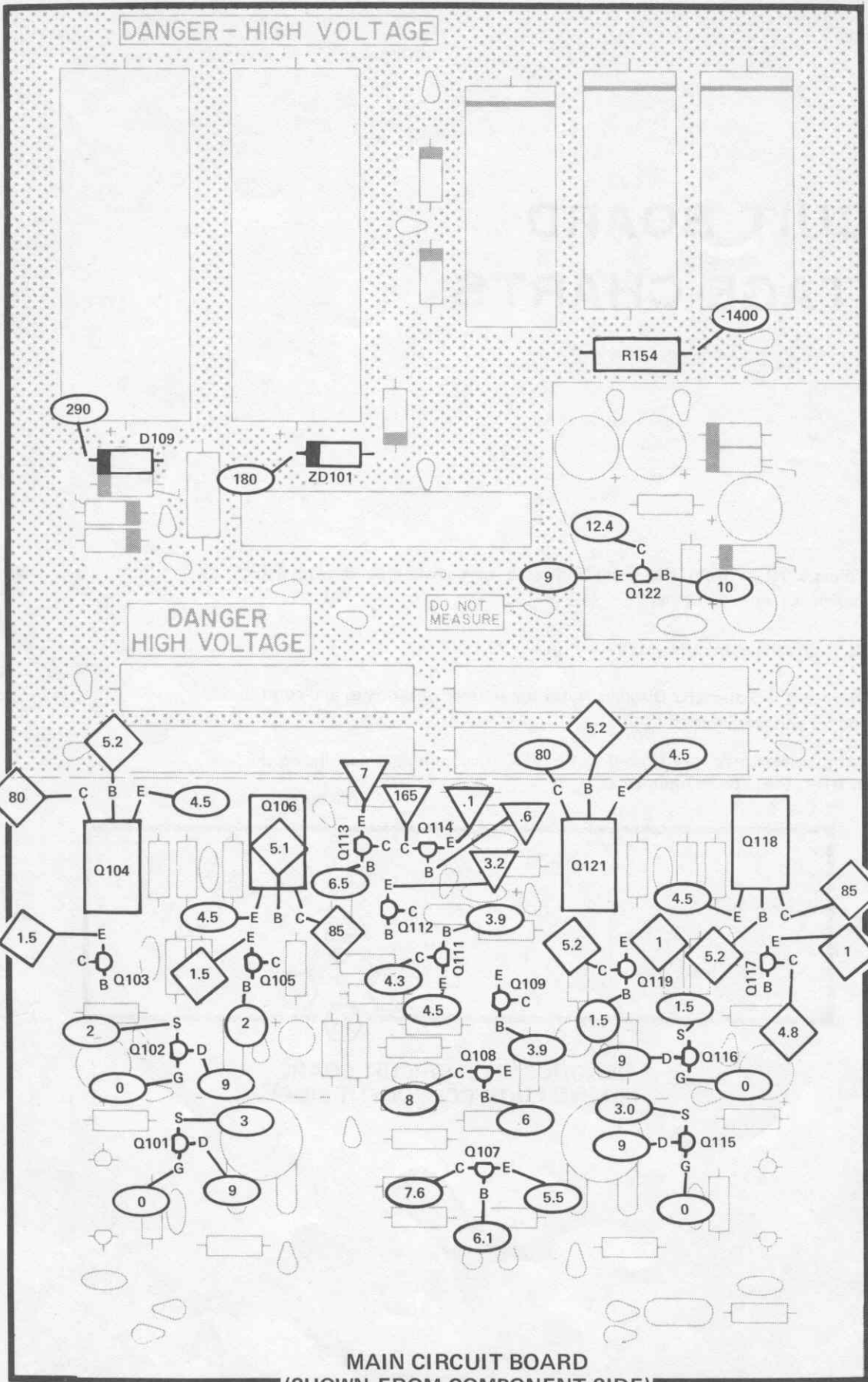

DANGER - HIGH VOLTAGE

290

D109

180

ZD101

1400

R154

12.4

9

Q122

10

DANGER HIGH VOLTAGE

DO NOT MEASURE

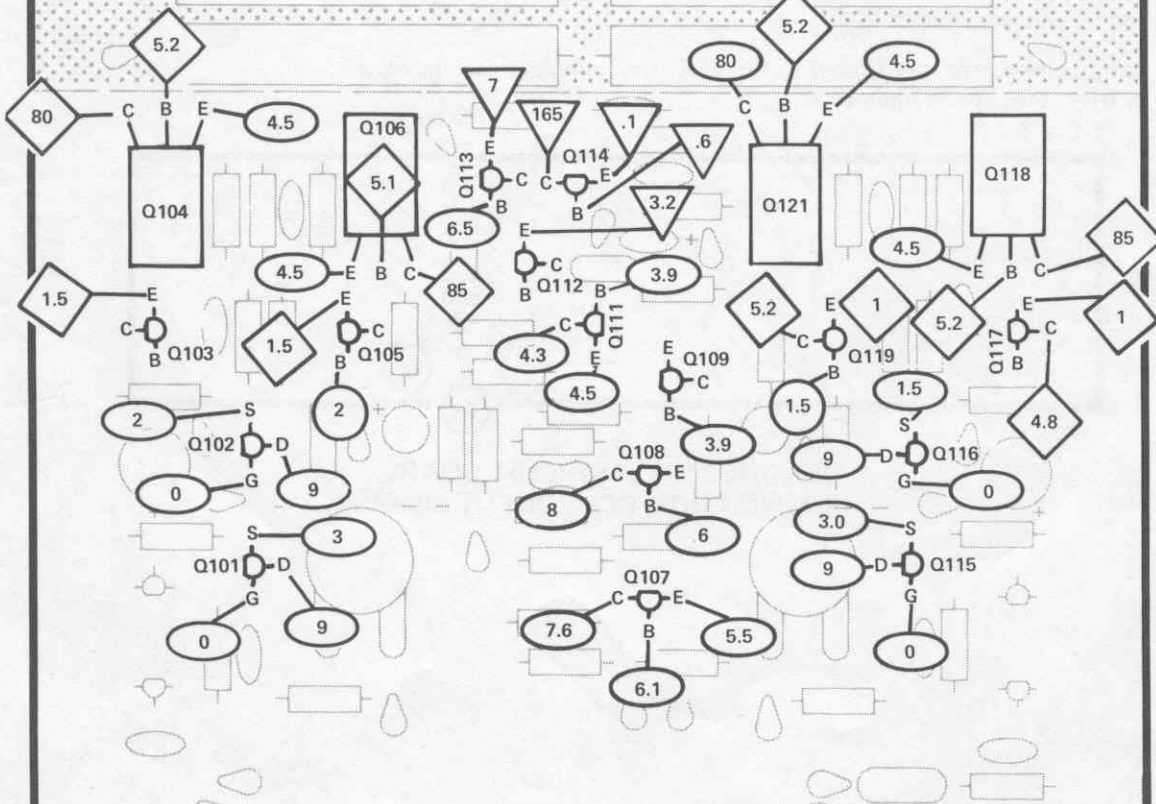

MAIN CIRCUIT BOARD
(SHOWN FROM COMPONENT SIDE)

TRANSISTOR IDENTIFICATION CHART

COMPONENT	HEATH PART NO.	MAY BE REPLACED WITH	IDENTIFICATION
Q103, Q105, Q117, Q119	417-91	2N5232A	
Q122	417-94	2N3416	
Q109, Q111, Q112, Q113	417-201	X29A829	
Q114	417-294	MPSA42	
D101, D102, D103, Q104, ZD201, Q107, Q108	417-801	MPSA20	
Q101, Q102, Q115, Q116	417-169	MPP105	
Q114	417-291	2N5458	
Q104, Q106, Q118, Q121	417-834	MPSU10	

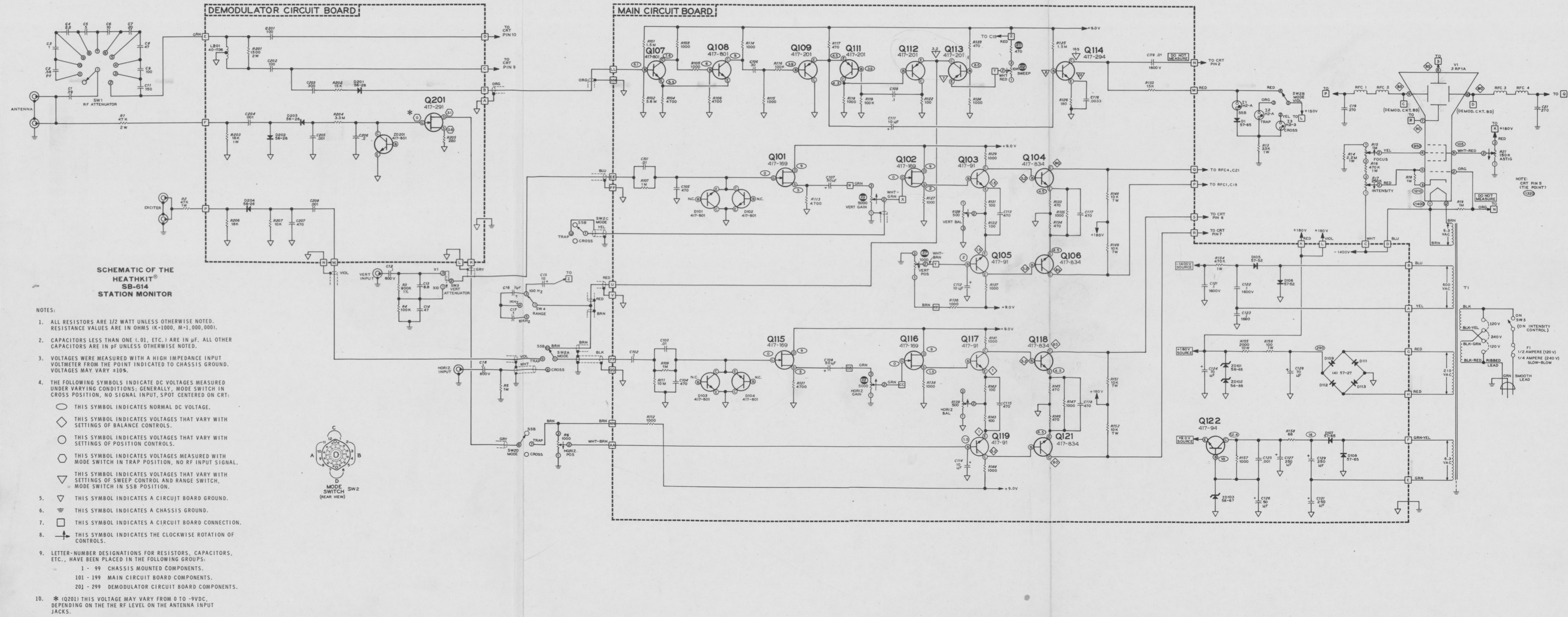

SCHMATIC OF THE HEATHKIT® SB-614 STATION MONITOR

- NOTES:
- ALL RESISTORS ARE 1/2 WATT UNLESS OTHERWISE NOTED. RESISTANCE VALUES ARE IN OHMS (K-1000, M-1,000,000).
 - CAPACITORS LESS THAN ONE (.01, ETC.) ARE IN μ F. ALL OTHER CAPACITORS ARE IN pF UNLESS OTHERWISE NOTED.
 - VOLTAGES WERE MEASURED WITH A HIGH IMPEDANCE INPUT VOLTMETER FROM THE POINT INDICATED TO CHASSIS GROUND. VOLTAGES MAY VARY $\pm 10\%$.
 - THE FOLLOWING SYMBOLS INDICATE DC VOLTAGES MEASURED UNDER VARYING CONDITIONS; GENERALLY, MODE SWITCH IN CROSS POSITION, NO SIGNAL INPUT, SPOT CENTERED ON CRT.
 - THIS SYMBOL INDICATES NORMAL DC VOLTAGE.
 - THIS SYMBOL INDICATES VOLTAGES THAT VARY WITH SETTINGS OF BALANCE CONTROLS.
 - THIS SYMBOL INDICATES VOLTAGES THAT VARY WITH SETTINGS OF POSITION CONTROLS.
 - THIS SYMBOL INDICATES VOLTAGES MEASURED WITH MODE SWITCH IN TRAP POSITION, NO RF INPUT SIGNAL.
 - THIS SYMBOL INDICATES VOLTAGES THAT VARY WITH SETTINGS OF SWEEP CONTROL AND RANGE SWITCH, MODE SWITCH IN SSB POSITION.
 - THIS SYMBOL INDICATES A CIRCUIT BOARD GROUND.
 - THIS SYMBOL INDICATES A CHASSIS GROUND.
 - THIS SYMBOL INDICATES A CIRCUIT BOARD CONNECTION.
 - THIS SYMBOL INDICATES THE CLOCKWISE ROTATION OF CONTROLS.
 - LETTER-NUMBER DESIGNATIONS FOR RESISTORS, CAPACITORS, ETC., HAVE BEEN PLACED IN THE FOLLOWING GROUPS:
 - 1 - 99 CHASSIS MOUNTED COMPONENTS.
 - 101 - 199 MAIN CIRCUIT BOARD COMPONENTS.
 - 201 - 299 DEMODULATOR CIRCUIT BOARD COMPONENTS.
 - * (Q201) THIS VOLTAGE MAY VARY FROM 0 TO -9VDC, DEPENDING ON THE THE RF LEVEL ON THE ANTENNA INPUT JACKS.

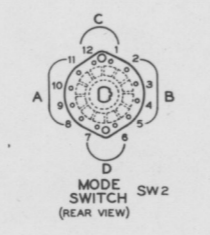

FOR PARTS REQUESTS ONLY

- Be sure to follow instructions carefully.
- Use a separate letter for all correspondence.
- Please allow 10 - 14 days for mail delivery time.

DO NOT WRITE IN THIS SPACE

INSTRUCTIONS

- Please print all information requested.
- Be sure you list the correct **HEATH** part number exactly as it appears in the parts list.
- If you wish to prepay your order, mail this card and your payment in an envelope. Be sure to include 10% (25¢ minimum, \$3.50 maximum) for insurance, shipping and handling. Michigan residents add 4% tax.
Total enclosed \$ _____
- If you prefer COD shipment, check the COD box and mail this form. COD

NAME _____

ADDRESS _____

CITY _____

STATE _____ ZIP _____

The information requested in the next two lines is not required when purchasing nonwarranty replacement parts, but it can help us provide you with better products in the future.

Model # _____ Invoice # _____

Date _____ Location _____

Purchased _____ Purchased _____

LIST HEATH PART NUMBER	QTY.	PRICE EACH	TOTAL PRICE

TOTAL FOR PARTS _____

HANDLING AND SHIPPING _____

MICHIGAN RESIDENTS ADD 4% TAX _____

TOTAL AMOUNT OF ORDER _____

SEND TO: **HEATH COMPANY**
BENTON HARBOR
MICHIGAN 49022
ATTN: PARTS REPLACEMENT

Phone (Replacement parts only): 616 982-3571

FOR PARTS REQUESTS ONLY

- Be sure to follow instructions carefully.
- Use a separate letter for all correspondence.
- Please allow 10 - 14 days for mail delivery time.

DO NOT WRITE IN THIS SPACE

INSTRUCTIONS

- Please print all information requested.
- Be sure you list the correct **HEATH** part number exactly as it appears in the parts list.
- If you wish to prepay your order, mail this card and your payment in an envelope. Be sure to include 10% (25¢ minimum, \$3.50 maximum) for insurance, shipping and handling. Michigan residents add 4% tax.
Total enclosed \$ _____
- If you prefer COD shipment, check the COD box and mail this form. COD

NAME _____

ADDRESS _____

CITY _____

STATE _____ ZIP _____

The information requested in the next two lines is not required when purchasing nonwarranty replacement parts, but it can help us provide you with better products in the future.

Model # _____ Invoice # _____

Date _____ Location _____

Purchased _____ Purchased _____

LIST HEATH PART NUMBER	QTY.	PRICE EACH	TOTAL PRICE

TOTAL FOR PARTS _____

HANDLING AND SHIPPING _____

MICHIGAN RESIDENTS ADD 4% TAX _____

TOTAL AMOUNT OF ORDER _____

SEND TO: **HEATH COMPANY**
BENTON HARBOR
MICHIGAN 49022
ATTN: PARTS REPLACEMENT

Phone (Replacement parts only): 616 982-3571

CUT ALONG DOTTED LINE

CUSTOMER SERVICE

REPLACEMENT PARTS

Please provide complete information when you request replacements from either the factory or Heath Electronic Centers. Be certain to include the **HEATH** part number exactly as it appears in the parts list.

ORDERING FROM THE FACTORY

Print all of the information requested on the parts order form furnished with this product and mail it to Heath. For telephone orders (parts only) dial 616 982-3571. If you are unable to locate an order form, write us a letter or card including:

- Heath part number.
- Model number.
- Date of purchase.
- Location purchased or invoice number.
- Nature of the defect.
- Your payment or authorization for COD shipment of parts not covered by warranty.

Mail letters to: Heath Company
Benton Harbor
MI 49022
Attn: Parts Replacement

Retain original parts until you receive replacements. Parts that should be returned to the factory will be listed on your packing slip.

OBTAINING REPLACEMENTS FROM HEATH ELECTRONIC CENTERS

For your convenience, "over the counter" replacement parts are available from the Heath Electronic Centers listed in your catalog. Be sure to bring in the original part and purchase invoice when you request a warranty replacement from a Heath Electronic Center.

TECHNICAL CONSULTATION

Need help with your kit? — Self-Service? — Construction? — Operation? — Call or write for assistance. you'll find our Technical Consultants eager to help with just about any technical problem except "customizing" for unique applications.

The effectiveness of our consultation service depends on the information you furnish. Be sure to tell us:

- The Model number and Series number from the blue and white label.
- The date of purchase.
- An exact description of the difficulty.
- Everything you have done in attempting to correct the problem.

Also include switch positions, connections to other units, operating procedures, voltage readings, and any other information you think might be helpful.

Please do not send parts for testing, unless this is specifically requested by our Consultants.

Hints: Telephone traffic is lightest at midweek — please be sure your Manual and notes are on hand when you call.

Heathkit Electronic Center facilities are also available for telephone or "walk-in" personal assistance.

REPAIR SERVICE

Service facilities are available, if they are needed, to repair your completed kit. (Kits that have been modified, soldered with paste flux or acid core solder, cannot be accepted for repair.)

If it is convenient, personally deliver your kit to a Heathkit Electronic Center. For warranty parts replacement, supply a copy of the invoice or sales slip.

If you prefer to ship your kit to the factory, attach a letter containing the following information directly to the unit:

- Your name and address.
- Date of purchase and invoice number.
- Copies of all correspondence relevant to the service of the kit.
- A brief description of the difficulty.
- Authorization to return your kit COD for the service and shipping charges. (This will reduce the possibility of delay.)

Check the equipment to see that all screws and parts are secured. (Do not include any wooden cabinets or color television picture tubes, as these are easily damaged in shipment. Do not include the kit Manual.) Place the equipment in a strong carton with at least **THREE INCHES** of *resilient* packing material (shredded paper, excelsior, etc.) on all sides. Use additional packing material where there are protrusions (control sticks, large knobs, etc.). If the unit weighs over 15 lbs., place this carton in another one with 3/4" of packing material between the two.

Seal the carton with reinforced gummed tape, tie it with a strong cord, and mark it "Fragile" on at least two sides. Remember, the carrier will not accept liability for shipping damage if the unit is insufficiently packed. Ship by prepaid express, United Parcel Service, or insured Parcel Post to:

Heath Company
Service Department
Benton Harbor, Michigan 49022



HEATH COMPANY • BENTON HARBOR, MICHIGAN
THE WORLD'S FINEST ELECTRONIC EQUIPMENT IN KIT FORM

LITHO IN U.S.A.