

Heathkit® Manual

for the

OSCILLOSCOPE CALIBRATOR Model IG-4505

595-1771-03



TABLE OF CONTENTS

Introduction	2	In Case of Difficulty	
Parts List	2	General	39
Step-by-Step Assembly	9	Troubleshooting	40
Circuit Board Checkout	18	Specifications	47
Terminal Strip Preparation	19	Circuit Description	48
Chassis Parts Mounting	24	Circuit Board X-Ray View	49
Chassis Wiring	26	Circuit Board Voltage Chart	49
Alternate Line Voltage Wiring	28	Identification Charts	50
Knob Installation	31	Schematic	In Illustration Booklet
Test and Calibration	32	Warranty	Inside front cover
Final Assembly	34	Customer Service	Inside rear cover
Operation	35		

HEATH COMPANY
BENTON HARBOR, MICHIGAN 49022

Copyright © 1975
Heath Company
All Rights Reserved



INTRODUCTION

The Heathkit Model IG-4505 Oscilloscope Calibrator is an accurate, crystal-controlled, fast-rise square wave generator. It provides you with the accurate time and amplitude signals you need to calibrate Heathkit Oscilloscopes, as well as most other oscilloscopes.

The time (or period) signals (.5 s to 1 μ s) are the fast-rise (less than 4 ns) square waves you need to adjust oscilloscope sweep speeds, delay line terminations, and high frequency compensation. A terminated output cable prevents ringing and assures a good frequency response of the time signal.

The accurate voltage signals (1 mV to 100 V) are used for oscilloscope vertical calibration and attenuator compensation.

The Calibrator also serves equally well as a bench standard. It can be used to calibrate other test equipment or as a signal source when you build or test experimental circuits.

Refer to the "Kit Builders Guide" for additional information on parts identification, tools, wiring and soldering.

PARTS LIST

Check each part against the following list. Make a check mark in the space provided (✓) as you identify each part. Any part that is packed in an individual envelope with a part number on it should be placed back in the envelope after you identify it until it is called for in a step. Do not discard any packing materials until all parts are accounted for.

To order a replacement part, always include the PART NUMBER. Use the Parts Order Form furnished with this kit. If one is not available, see "Replacement Parts" inside the rear cover of the Manual. Your Warranty is located inside the front cover. For pricing information, refer to the separate "Heath Parts Price List."

Each circuit part in this kit has its own "circuit component number" (R2, C4, Q101, etc.). This is a specific number for only that one part. The purpose of these numbers is to help you easily identify the same part in each section of the Manual. These numbers will appear:

- In the Parts List;
- At the beginning of each step where a component is installed;
- In some illustrations;
- On the Schematic;
- In the sections at the rear of the Manual.

KEY No.	QTY.	DESCRIPTION	PART No.	CIRCUIT Component No.
---------	------	-------------	----------	-----------------------

RESISTORS

NOTE: The following resistors have a tolerance of 5% unless they are listed otherwise. 5% is indicated by a fourth color band of gold. 10% is indicated by a silver fourth band. The resistors may be packed in more than one envelope.

1/4-Watt

A1 (∠)	1	10 Ω (brown-black-black)	6-100-12	R25
A1 (×)	1	.51 Ω (green-brown-black)	6-510-12	R104
A1 (∠)	7	1000 Ω (brown-black-red)	6-102-12	R3, R4, R5, R6, R7, R8, R9

A1

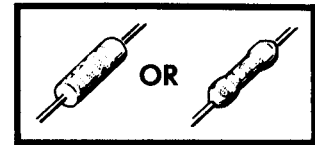

1/2-Watt

A2 (→)	1	1 Ω, .5%	2-1	R22
A2 (×)	1	9 Ω, .5%	2-2	R21
A2 (∠)	1	90 Ω, .5%	2-3	R19
A2 (∠)	1	900 Ω, .5%	2-5	R18
A2 (∠)	1	4000 Ω (4 k), 1%	2-113	R17
A2 (∠)	1	5000 Ω (5 k), 1%	2-247	R16
A2 (∠)	1	90 kΩ, .5%	2-10	R15
A3 (∠)	1	1.5 Ω, 10% (brown-green-gold)	6-159	R29
A3 (∠)	1	51 Ω (green-brown-black)	6-510	R26
A3 (∠)	1	120 Ω (brown-red-brown)	6-121	R102
A3 (∠)	1	180 Ω (brown-gray-brown)	6-181	R103
A3 (∠)	1	220 Ω, 10% (red-red-brown)	6-221	R24
A3 (∠)	4	470 Ω (yellow-violet-brown)	6-471	R2, R11, R12, R28
A3 (∠)	1	680 Ω (blue-gray-brown)	6-681	R27
A3 (∠)	1	820 Ω (gray-red-brown)	6-821	R23
A3 (∠)	1	1000 Ω, 10% (brown-black-red)	6-102	R101
A3 (∠)	1	27 kΩ, 10% (red-violet-orange)	6-273	R105
A3 (∠)	1	100 kΩ (brown-black-yellow)	6-104	R1

A2

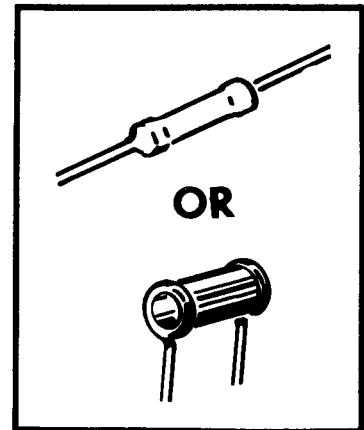

A3

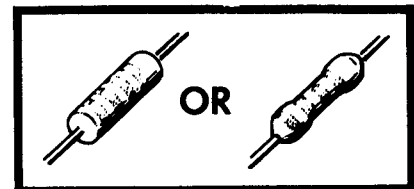

KEY No.	QTY.	DESCRIPTION	PART No.	CIRCUIT Component No.
---------	------	-------------	----------	-----------------------



1 - Watt

A4 (✓)	1	10 kΩ, 10% (brown-black-orange)	1-9-1	R13
--------	---	---------------------------------	-------	-----

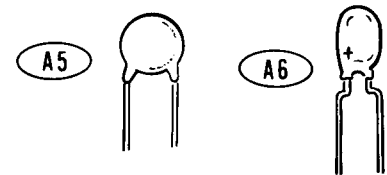

CAPACITORS

A5 (✓)	2	10 pF ceramic	21-3	C1, C9
A5 (✓)	1	47 pF ceramic	21-32	C2
A5 (✓)	5	.01 μF ceramic	21-16	C3, C4, C5, C6, C7
A6 (✓)	1	15 μF tantalum	25-252	C8
A7 (✓)	2	40 μF electrolytic	25-20	C101, C102
A7 (✓)	2	1000 μF electrolytic	25-111	C103, C104

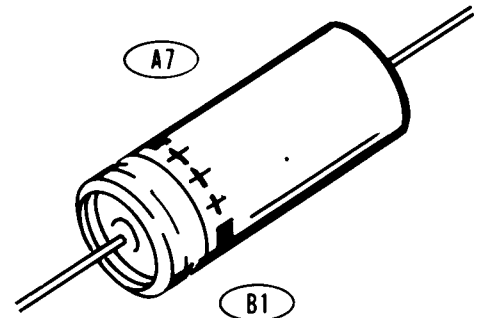

DIODES-TRANSISTORS-INTEGRATED CIRCUITS

B1 (✓)	1	BZT110A zener diode	56-48	ZD1
B1 (✓)	1	1N4149 diode	56-56	D2
B1 (✓)	1	MZ500-10 zener diode	56-63	ZD102
B1 (✓)	1	SZ5.0 zener diode	56-85	ZD101
B1 (✓)	8	1N2071 diode	57-27	D3, D4, D5, D6, D7, D8, D9, D10

NOTE: HEATH PART NUMBERS ARE STAMPED ON MOST DIODES.

NOTE: Transistors and integrated circuits are marked for identification in one of the following four ways:

1. Part number.
2. Type number. (For integrated circuits this refers only to the numbers, the letters may vary.)
3. Part number and type number.
4. Part number with a type number other than the one listed.

B2 (✓)	1	2N3393 transistor	417-118	Q1
B2 (✓)	2	2N5771 transistor	417-292	Q4, Q5
B2 (✓)	2	MPSL01 transistor	417-811	Q2, Q3
B3 (✓)	1	2N5294 transistor	417-175	Q101
B4 (✓)	1	SN7474N integrated circuit	443-6	IC1
B4 (✓)	6	SN7490N integrated circuit	443-7	IC2, IC3, IC4, IC5, IC6, IC7

B2

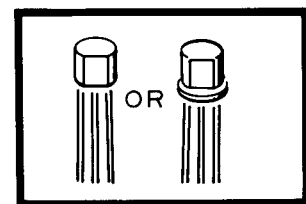

B3

B4

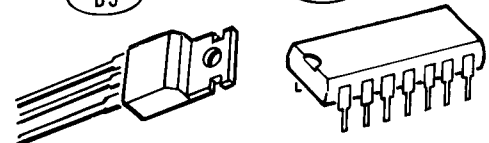

KEY No.	QTY.	DESCRIPTION	PART No.	CIRCUIT Component No.
---------	------	-------------	----------	-----------------------

CONTROL SWITCHES

B4 (X)	1	20 kΩ control	10-390	R14
B5 (A)	1	2-position slide switch	60-1	SW101
B6 (C)	1	3-position slide switch	60-73	SW102
B7 (K)	2	7-position rotary switch	63-1237	SW1, SW2

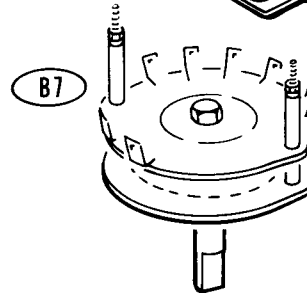
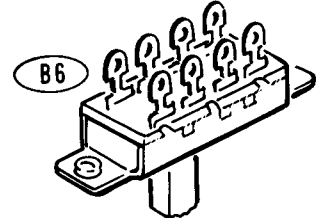
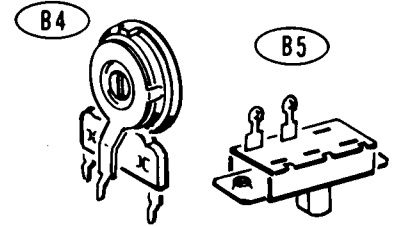
TERMINAL STRIPS-CONNECTORS-SOCKETS

C1 ()	1	5-lug terminal strip	431-42
C2 ()	1	6-lug terminal strip	431-86
C3 ()	1	7-lug terminal strip	431-35
C4 ()	1	Terminal collar	431-82
C5 ()	1	BNC connector	432-919
C6 ()	1	Connector pin	432-134
C7 ()	7	14-pin socket	434-298

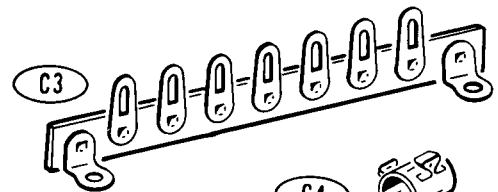
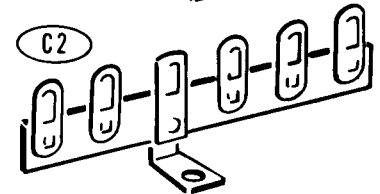
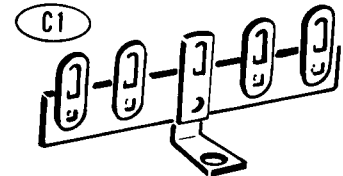

C5

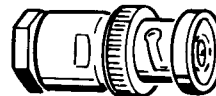

C6



C7

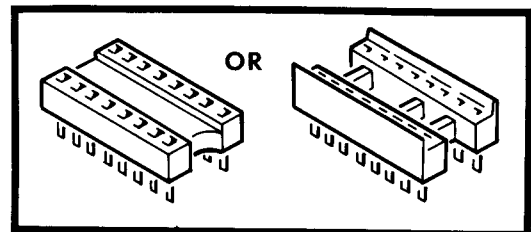

KEY No.	QTY.	DESCRIPTION	PART No.	CIRCUIT Component No.
---------	------	-------------	----------	-----------------------

HARDWARE

NOTE: The hardware may be in more than one packet. Open all hardware packets in this pack before you check the hardware against the Parts List. The hardware is shown actual size.

#6 Hardware

D1	4	#6 x 1/4" sheet metal screw	250-170
D2	12	6-32 x 3/8" screw	250-89
D3	12	6-32 nut	252-3
D4	13	#6 lockwasher	254-1
D5	5	#6 solder lug	259-1

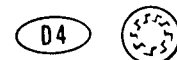
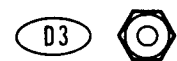
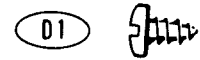

Other Hardware

D6	4	4-40 nut	252-15
D7	2	Control nut	252-7
D8	2	Control flat washer	253-10
D9	1	Push-on nut	252-9

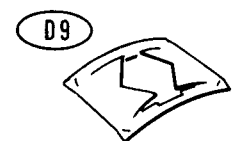
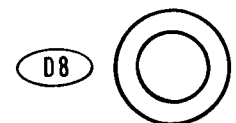
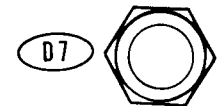
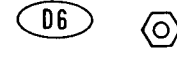

WIRE-SLEEVING

(S)	8"	Red	344-52
(S)	48"	Blue	344-56
(S)	8"	White-red	344-72
(S)	9"	White-yellow	344-74
(S)	26"	Black stranded	344-2
(S)	36"	Large shielded cable	343-2
(S)	12"	Small shielded cable	343-15
(S)	1-1/2"	Large clear sleeving	346-60
(S)	5"	Small clear sleeving	346-2
(S)	2-1/2"	Heat-shrinkable sleeving	346-46
(S)	6'	Line cord	89-23

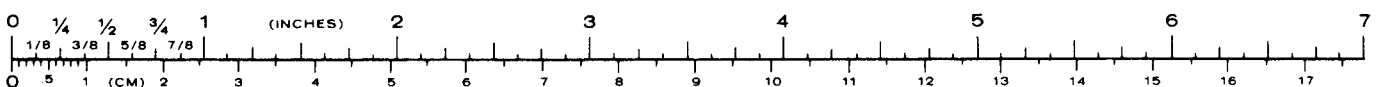

KEY No.	QTY.	DESCRIPTION	PART No.	CIRCUIT Component No.
---------	------	-------------	----------	-----------------------

MISCELLANEOUS

	1	Power transformer	54-905	T101
	1	Circuit board	85-1660-2	
E1	1	Grommet	73-4	
E2	4	Binding post insulator	75-17	
E3	2	Binding post base	427-3	
E4	1	Black binding post cap	100-16-2	
	1	Red binding post cap	100-16-18	
E5	1	Switch insulator	75-52	
E6	1	Strain relief	75-71	

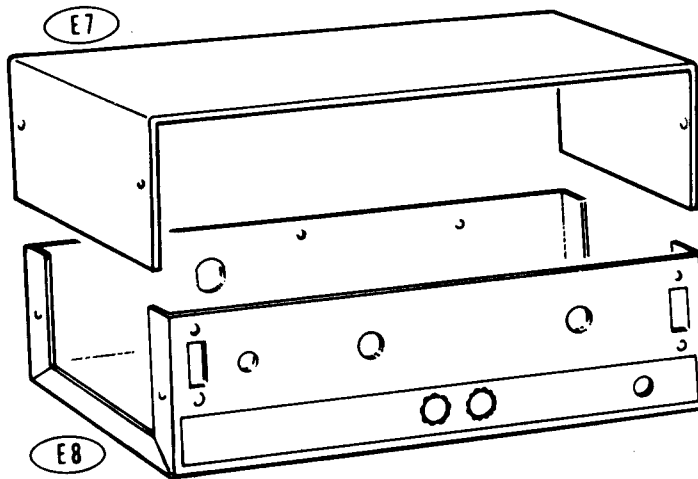

E7	1	Cabinet shell	90-320-2	
E8	1	Chassis	200-1238-1	
E9	4	Rubber foot	261-1	
E10	2	Tie	354-6	
E11	1	4 MHz crystal	404-536	Y1

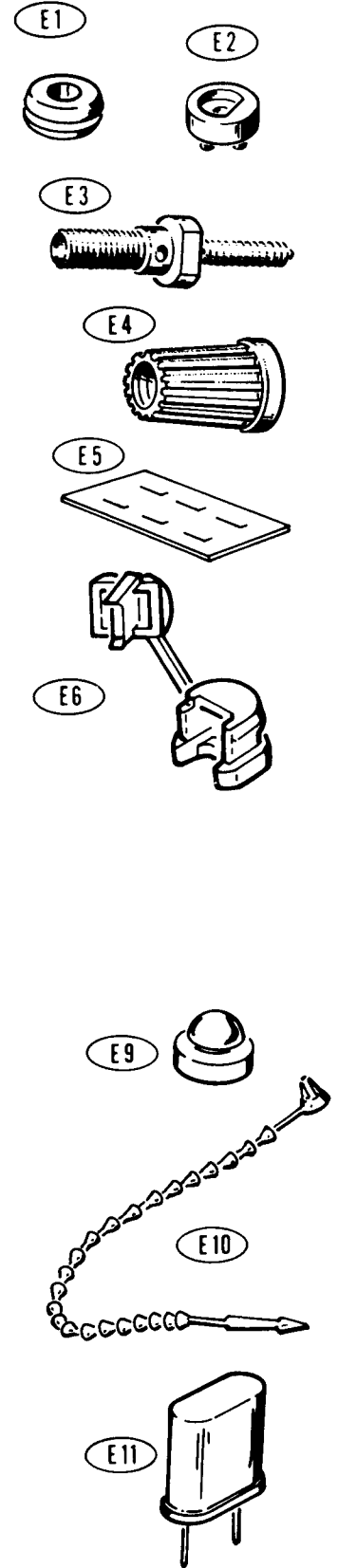

KEY No.	QTY.	DESCRIPTION	PART No.	CIRCUIT Component No.
---------	------	-------------	----------	-----------------------

MISCELLANEOUS (cont'd.)

E12	(1)	1 Neon lamp	412-15	PL101
E13	(1)	1 Red lens	413-10	
E14	(1)	1 3/16-ampere slow-blow fuse	421-40	
E15	(2)	2 Knob bushing	455-619	
E16	(2)	2 Knob	462-264	
	(1)	1 Fuse label	390-1255	
	(1)	1 Blue and white label	391-34	
E17	(1)	1 Nut starter	490-5	
	(1)	1 Parts Order Form	597-260	
	(1)	1 Kit Builders Guide	597-308	
		Solder		
	(1)	1 Assembly Manual (See front cover for part number.)		

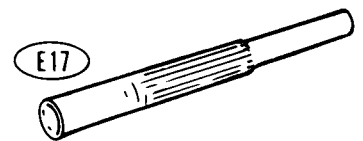
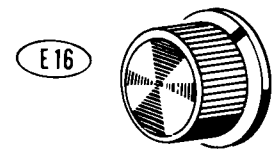
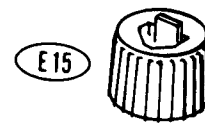
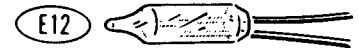

STEP-BY-STEP ASSEMBLY

IMPORTANT:

1. Before you start to assemble this kit, read the wiring and soldering information in the "Kit Builders Guide."
2. Due to the small foil area around the circuit board holes and the small areas between foils, it will be necessary to use the *utmost* care to prevent solder bridges between adjacent foil areas. Use only a minimum amount of solder and use no larger than a 40-watt soldering iron with a small tip. Allow it to reach operating temperature and then apply it only long enough to make a good solder connection.
3. Resistors will be called out by their resistance value in Ω , $k\Omega$ or $M\Omega$, and by their first three color bands. The fourth color band is normally gold, which indicates a 5% tolerance. However, when a tolerance of 10% is given in a step, the fourth color band will be silver.
4. Capacitors will be called out by their capacitance value (in pF or μF) and type (ceramic, tantalum, or electrolytic).
5. A separate "Illustration Booklet" contains numbered illustrations (Pictorials, Details, etc.) that are too large for the Assembly Manual. The Step-by-Step Assembly instructions will direct you to the proper illustration in the Booklet. After you have completed the assembly of your kit, place the Illustration Booklet with the Assembly Manual and save them for future reference.

SAFETY WARNING: Avoid eye injury when you clip off excess lead lengths. We suggest that you hold the leads, or at least clip the leads so the ends will not fly toward your eyes.

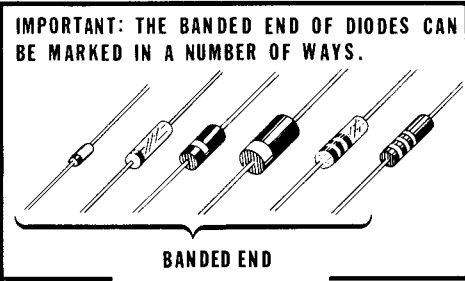

Detail 1-1A

START

Position the circuit board as shown. Then complete each step on the Pictorial.

NOTE: When you install a diode, always match the band on the diode with the band mark on the circuit board. A DIODE WILL NOT WORK IF IT IS INSTALLED BACKWARDS. See Detail 1-1A.

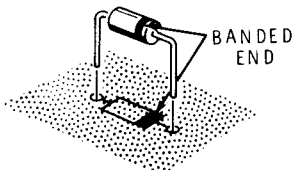

(*) Install eight 1N2071 diodes (#57-27) at D9, D7, D10, D8, and D5, D3, D6, D4.

(A) ZD1: BZT110A zener diode (#56-48).

(X) D2: 1N4149 diode (#56-56).

(L) Solder the leads to the foil and cut off the excess lead lengths.

(f) R26: 51 Ω (green-brown-black). Use the 1/2-watt resistor.

(X) R29: 1.5 Ω (brown-green-gold).

(L) R25: 10 Ω, 1/4-watt (brown-black-black).

(X) R28: 470 Ω (yellow-violet-brown).

NOTE: To prepare wires as in the following steps, cut them to the indicated lengths and remove 1/4" of insulation from each end. When bare wire is called for, cut a blue wire to the indicated length and remove all of the insulation.

(L) Prepare the following wires:
 3" blue
 1" bare

() 3" blue wire.

(L) 1" bare wire.

(L) Solder the leads to the foil and cut off the excess lead lengths.

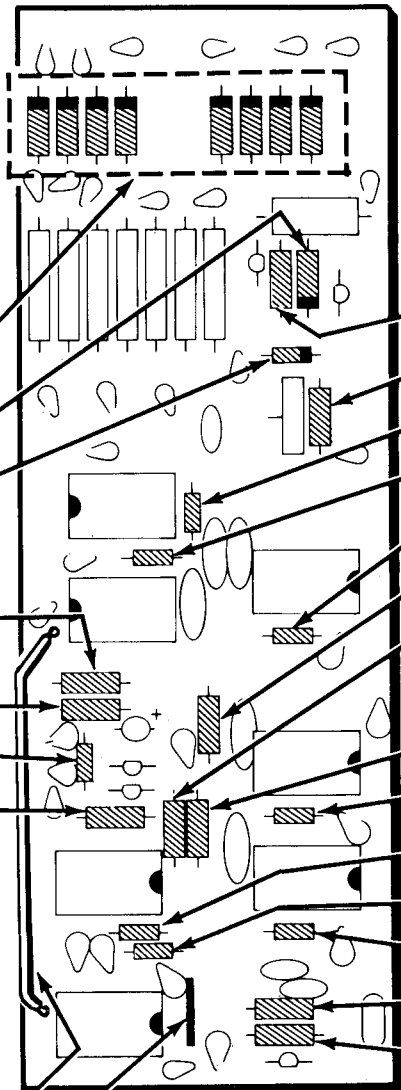

PICTORIAL 1-1

CONTINUE

- (X) R12: 470 Ω (yellow-violet-brown).
- (X) R11: 470 Ω (yellow-violet-brown).
- (L) R6: 1000 Ω, 1/4-watt (brown-black-red).
- (L) R5: 1000 Ω, 1/4-watt (brown-black-red).
- (L) R7: 1000 Ω, 1/4-watt (brown-black-red).
- (X) R23: 820 Ω (gray-red-brown).
- (X) R24: 220 Ω (red-red-brown).
- (L) Solder the leads to the foil and cut off the excess lead lengths.
- (L) R27: 680 Ω (blue-gray-brown).
- (X) R8: 1000 Ω, 1/4-watt (brown-black-red).
- (L) R3: 1000 Ω, 1/4-watt (brown-black-red).
- (L) R4: 1000 Ω, 1/4-watt (brown-black-red).
- (L) R9: 1000 Ω, 1/4-watt (brown-black-red).
- (X) R2: 470 Ω (yellow-violet-brown).
- (L) R1: 100 kΩ (brown-black-yellow).

FOR GOOD SOLDER CONNECTIONS, YOU MUST KEEP THE SOLDERING IRON TIP CLEAN.
 WIPE IT OFTEN WITH A DAMP SPONGE OR CLOTH.

(L) Solder the leads to the foil and cut off the excess lead lengths.

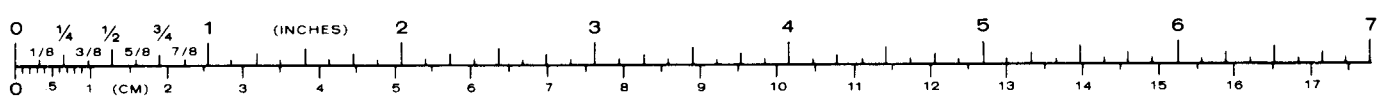

START

NOTE: To install a 14-pin integrated circuit socket. Insert the socket pins into the holes. The index mark on the circuit board should still be visible after it is installed. Solder the pins to the foil.

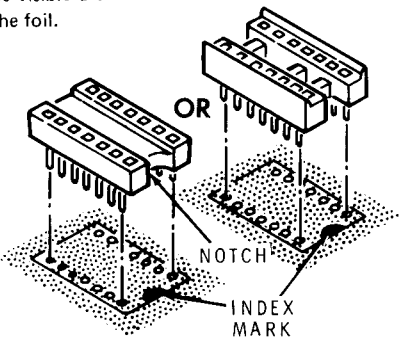

- 14-pin socket at IC4.
- 14-pin socket at IC3.
- 14-pin socket at IC5.
- 14-pin socket at IC6.
- 14-pin socket at IC7.
- 14-pin socket at IC2.
- 14-pin socket at IC1.

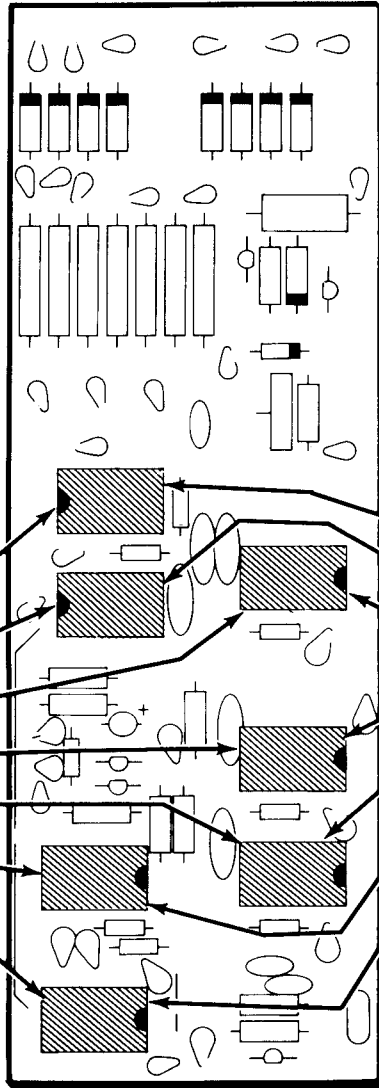

CONTINUE

In the following steps, install IC's (integrated circuits) in the designated sockets. Be careful to match the pin 1 end of each IC to the index mark on the circuit board. See Detail 1-2A (below).

Before you apply downward pressure to an IC, make sure each IC pin is centered in its proper socket aperture. Handle IC's with care, as their pins bend very easily.

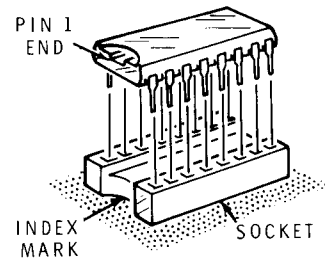

- IC4: SN7490N IC (#443-7).
- IC3: SN7490N IC (#443-7).
- IC5: SN7490N IC (#443-7).
- IC6: SN7490N IC (#443-7).
- IC7: SN7490N IC (#443-7).
- IC2: SN7490N IC (#443-7).
- IC1: SN7474N IC (#443-6).
- Check each integrated circuit to make sure the pin 1 end is nearest the dot on the circuit board.

PICTORIAL 1-2

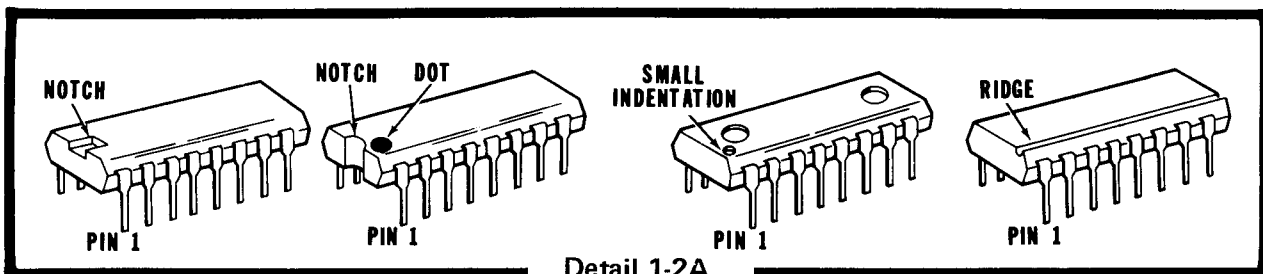

Detail 1-2A

START ▾

NOTE: The .5% resistors you install in the following steps may be shaped as shown below.

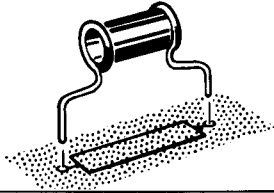

() R15: 90 kΩ, .5%.

() R16: 5000 Ω (5 k), 1%.

() R17: 4000 Ω (4 k), 1%.

() R18: 900 Ω, .5%.

() R19: 90 Ω, .5%.

() R21: 9 Ω, .5%

() R22: 1 Ω, .5%.

Solder the leads to the foil and cut off the excess lead lengths.

NOTE: When you install disc capacitors, do not push the insulated portions of the leads into the circuit board holes. This could make it difficult to solder the leads to the foil.

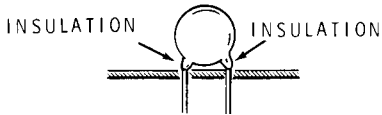

() C9: 10 pF ceramic.

() C5: .01 μF ceramic.

() C4: .01 μF ceramic.

() C3: .01 μF ceramic.

NOTE: When you install a tantalum capacitor, always match the positive (+) or dot marked side of the capacitor with the positive (+) mark on the circuit board.

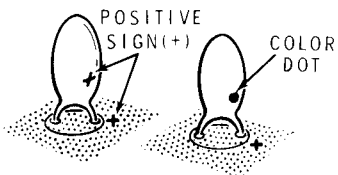

() C8: 15 μF tantalum.

() C1: 10 pF ceramic.

() C2: 47 pF ceramic.

Solder the leads to the foil and cut off the excess lead lengths.

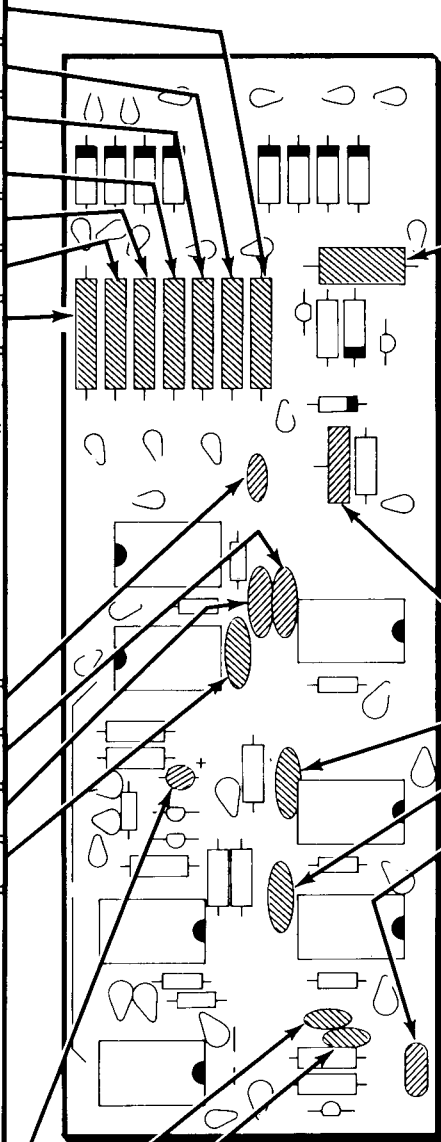

CONTINUE ▾

(X) R13: 10 kΩ, 1-watt (brown-black-orange).

NOTE: As you install the following control, solder the leads to the foil.

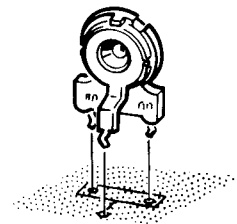

(X) R14: 20 kΩ control.

(X) C6: .01 μF ceramic.

(X) C7: .01 μF ceramic.

(X) Y1: 4 MHz crystal.

() Solder the leads to the foil and cut off the excess lead lengths.

PICTORIAL 1-3

START ▾

CAUTION: The E, B, and C leads can be in different positions for different transistor types. Be sure to look at the illustrations carefully each time you are given mounting instructions for transistors.

(X) Locate the following parts:

Two MPSL01 transistors (#417-811).

Two 2N5771 transistors (#417-292).

In the following steps, install each transistor as follows:

1. Refer to the illustration below and identify the E, B, and C leads of the transistor.
2. Insert the transistor leads into the corresponding E, B, and C holes in the circuit board.
3. Position the transistor 1/4" above the circuit board.
4. Turn the circuit board over, solder the leads to the foil, and cut off the excess lead lengths.

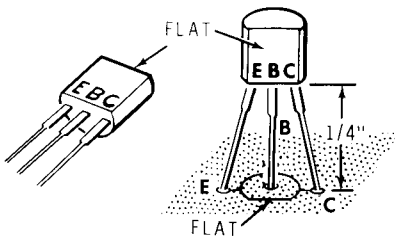

(✓) Q2: MPSL01 transistor (#417-811).

(✓) Q3: MPSL01 transistor (#417-811).

() Q4: 2N5771 transistor (#417-292).

() Q5: 2N5771 transistor (#417-292).

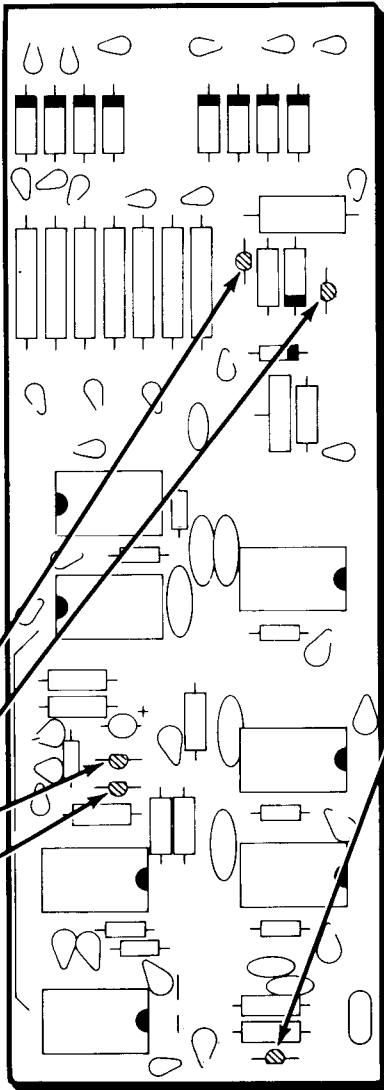

CONTINUE ▾

() Locate a 2N3393 transistor (#417-118).

() Q1: Install a 2N3393 transistor (#417-118) as follows:

1. Refer to the illustrations below and identify the E, C, and B leads of the transistor. The transistor supplied with your kit may not have a skirt as shown.
2. Insert the transistor leads into the corresponding E, C, and B holes in the circuit board.
3. Position the transistor 1/4" above the circuit board.
4. Turn the circuit board over, solder the leads to the foil, and cut off the excess lead lengths.

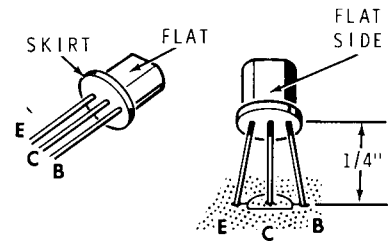

(✓) Check each of these transistors to make sure the flat on the transistor faces the same direction as the flat shown on the circuit board.

PICTORIAL 1-4

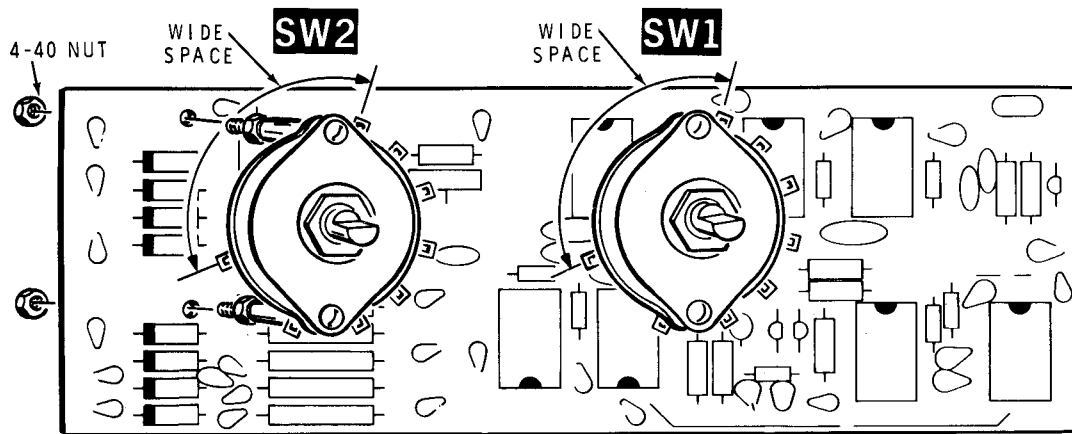

PICTORIAL 1-5

Refer to Pictorial 1-5 for the following steps.

(X SW1: Likewise, mount a 7-position rotary switch at SW1.

NOTE: Use the nut starter to start 4-40 and 6-32 nuts on screws.

Refer to Pictorial 1-6 for the following steps.

() SW2: Mount a 7-position rotary switch at SW2 with two 4-40 nuts. Install the switch so the wide space between the lugs is positioned as shown.

When wiring this kit, you will be instructed to prepare lengths of wire ahead of time as in the following step. To prepare a wire, cut it to the indicated length and then remove 1/4" of insulation from each end.

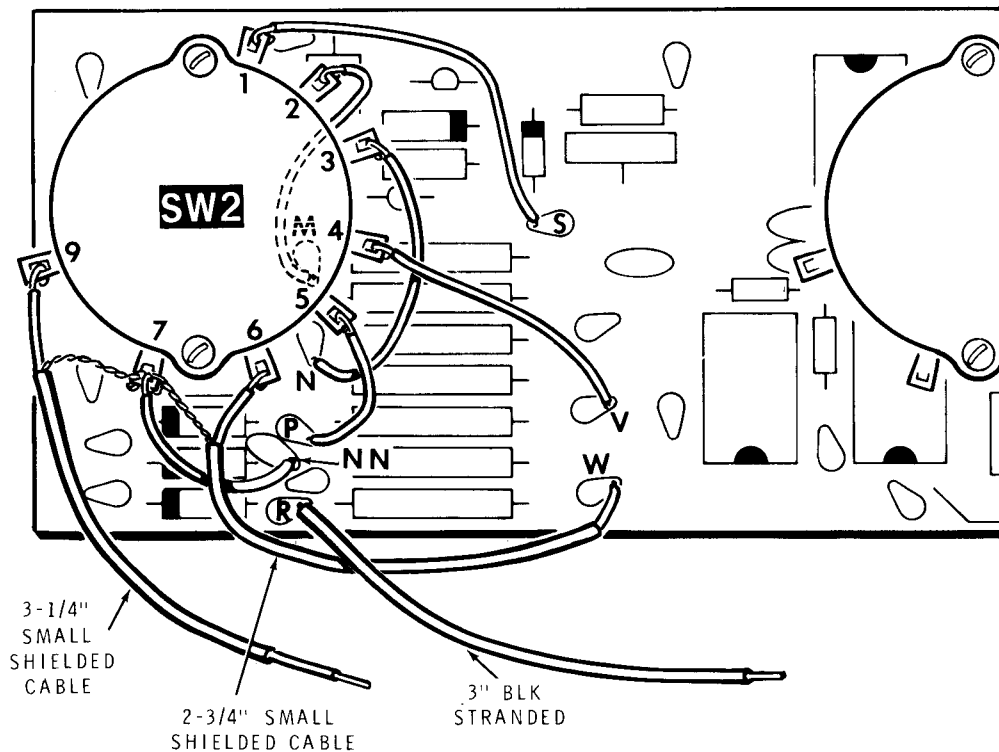

PICTORIAL 1-6

For stranded wire, twist the fine strands tightly together and melt a small amount of solder on the bare wire ends. The wires are listed in the order in which they will be used.

(1) Prepare the following wires:

- 2-1/2" blue
- two 2" blue
- 2-1/2" blue
- two 2" blue
- 3" black stranded

NOTE: In the following steps, "S-" with a number, such as (S-3), means to solder the connection. The number following the "S" tells how many wires are at the connection. (NS) means not to solder because other wires will be added later.

- (2) Connect a 2-1/2" blue wire from switch SW2 lug 1 (S-1) to circuit board hole S (S-1).
- (3) Connect a 2" blue wire from switch SW2 lug 2 (S-1) to circuit board hole M (S-1).
- (4) Connect a 2" blue wire from switch SW2 lug 3 (S-1) to circuit board hole N (S-1).
- (5) Connect a 2-1/2" blue wire from switch SW2 lug 4 (S-1) to circuit board hole V (S-1).
- (6) Connect a 2" blue wire from switch SW2 lug 5 (S-1) to circuit board hole P (S-1).
- (7) Connect a 2" blue wire from switch SW2 lug 7 (NS) to circuit board hole NN (S-1).
- (8) Connect one end of a 3" black stranded wire to circuit board hole R (S-1). The other end will be connected later.

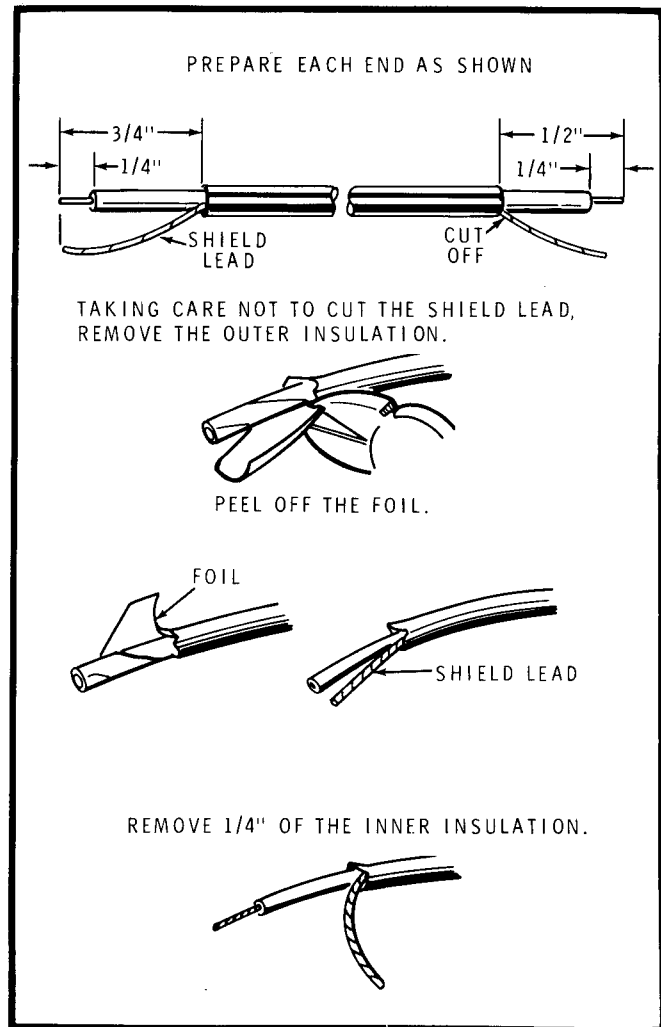

Detail 1-6A

- (9) Refer to Detail 1-6A and prepare the following lengths of small shielded cable:
 - 2-3/4"
 - 3-1/4"
- (10) At the end of a 2-3/4" small shielded cable with the shield lead, connect the inner lead to switch SW2 lug 6 (S-1) and the shield lead to switch SW2 lug 7 (NS). Connect the inner lead at the other end of this cable to circuit board hole W (S-1).
- (11) At the end of a 3-1/4" small shielded cable with the shield lead, connect the inner lead to switch SW2 lug 9 (S-1) and the shield lead to switch SW2 lug 7 (S-3). The free end of this cable will be connected later.

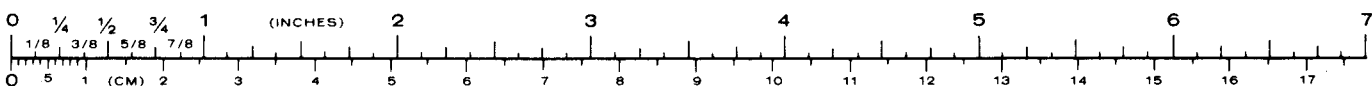

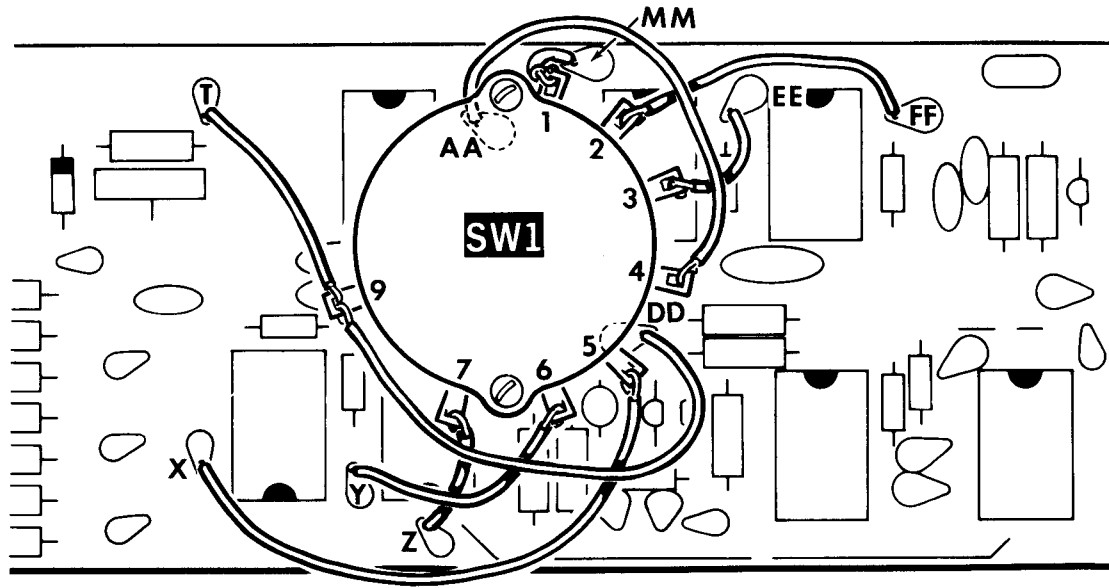

PICTORIAL 1-7

Refer to Pictorial 1-7 for the following steps.

Prepare the following blue wires:

- 1-1/4"
- 2"
- 1-3/4"
- 3"
- 3-1/2"
- 2-1/4"
- 1-1/2"
- 3-1/2"
- 2"

- Connect a 1-1/4" blue wire from switch SW1 lug 1 (S-1) to circuit board hole MM (S-1).
- Connect a 2" blue wire from switch SW1 lug 2 (S-1) to circuit board hole FF (S-1).
- Connect a 1-3/4" blue wire from switch SW1 lug 3 (S-1) to circuit board hole EE (S-1).
- Connect a 3" blue wire from switch SW1 lug 4 (S-1) to circuit board hole AA (S-1).

- Connect a 3-1/2" blue wire from switch SW1 lug 5 (S-1) to circuit board hole X (S-1).
- Connect a 2-1/4" blue wire from switch SW1 lug 6 (S-1) to circuit board hole Y (S-1).
- Connect a 1-1/2" blue wire from switch SW1 lug 7 (S-1) to circuit board hole Z (S-1).
- Connect a 3-1/2" blue wire from switch SW1 lug 9 (NS) to circuit board hole DD (S-1).
- Connect a 2" blue wire from switch SW1 lug 9 (S-2) to circuit board hole T (S-1).

Refer to Pictorial 1-8 for the following steps.

Prepare the following wires:

- 2" white-yellow
- 1-3/4" blue
- 1" blue
- 1-3/4" white-red
- 1-3/4" red

- Remove an additional 1/2" of insulation (3/4" total) from one end of the 2" white-yellow.

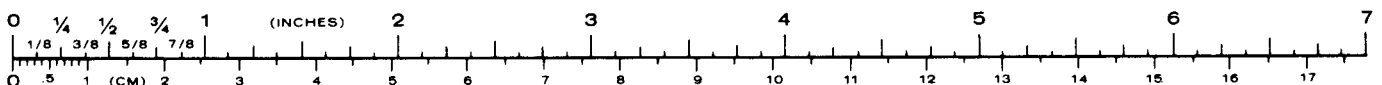

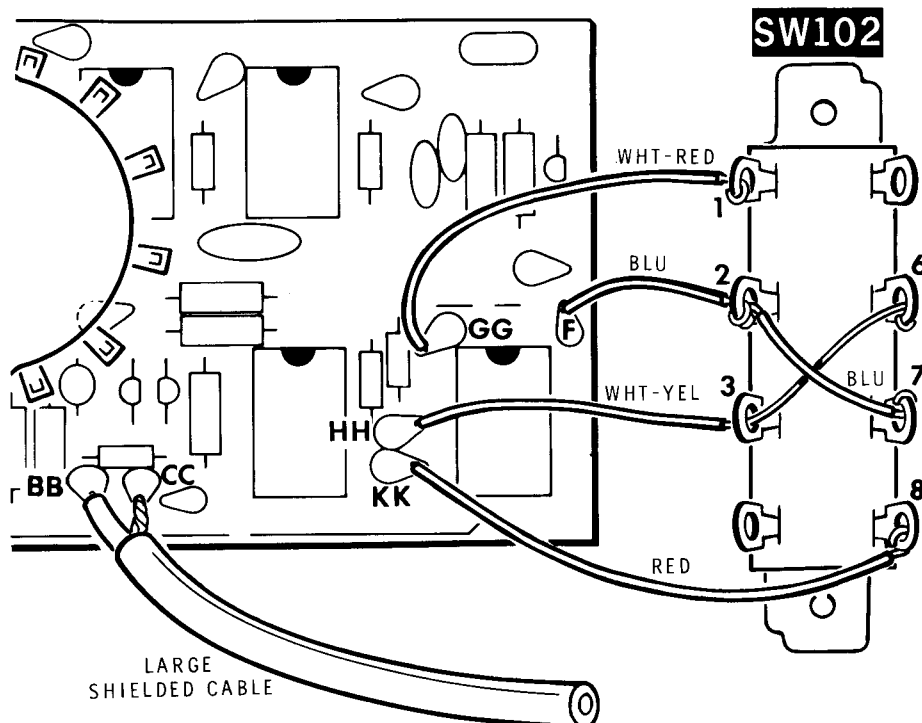

PICTORIAL 1-8

- () Locate the 3-position slide switch and position it as shown in Pictorial 1-8.

NOTE: Where a wire passes through a connection and then goes to another point, as in the next step, it will count as two wires in the solder instructions (S-2), one entering and one leaving the connection.

- (✓) Connect the 3/4" prepared end of the 2" white-yellow wire to switch SW102 through lug 3 (S-2) to lug 6 (S-1). Connect the other end to circuit board hole HH (S-1).
- (✓) Connect a 1-3/4" blue wire from switch SW102 lug 2 (NS) to circuit board hole F (S-1).
- (✓) Connect a 1" blue wire to switch SW102 between lugs 2 (S-2) and 7 (S-1).
- (✓) Connect a 1-3/4" white-red wire from switch SW102 lug 1 (S-1) to circuit board hole GG (S-1).
- (✓) Connect a 1-3/4" red wire from switch SW102 lug 8 (S-1) to circuit board hole KK (S-1).
- (✓) Refer to Detail 1-8A and prepare one end of the large shielded cable. Do not shorten this cable.
- (✓) Connect the inner lead of the large shielded cable to circuit board hole BB (S-1). Connect the shield lead to circuit board hole CC (S-1). The free end will be connected later.

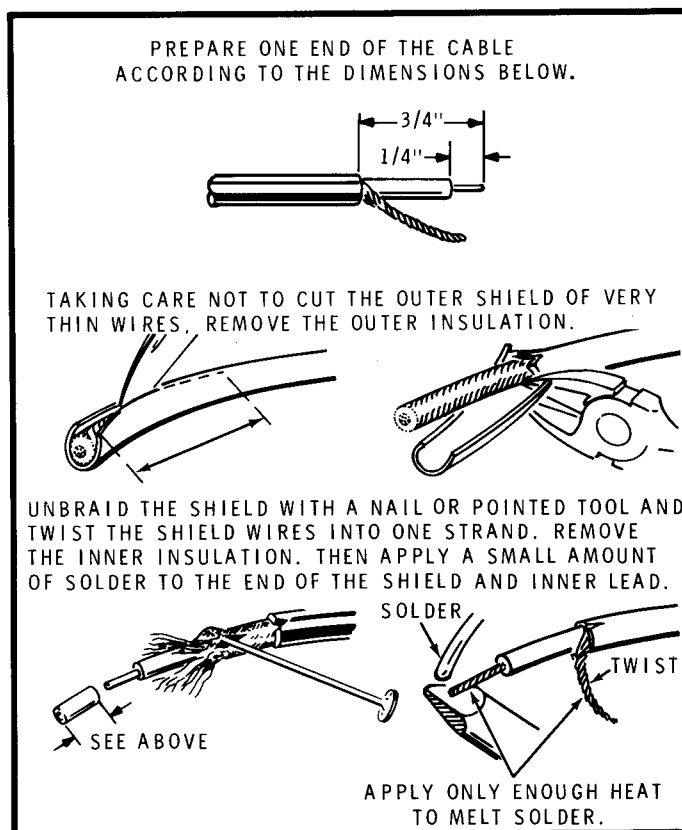

Detail 1-8A

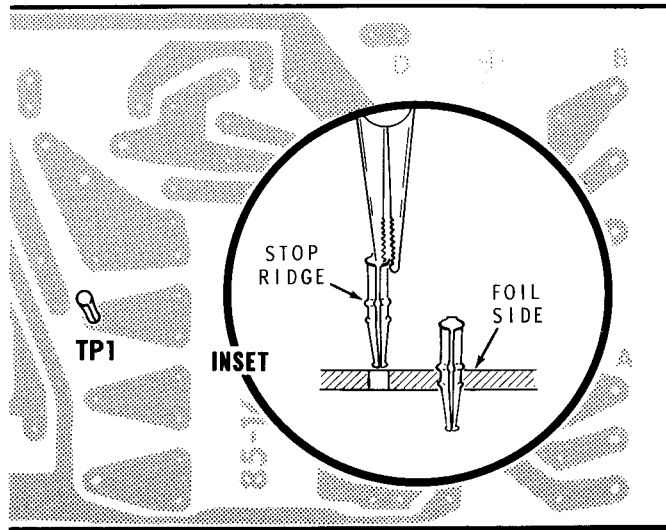

PICTORIAL 1-9

Refer to Pictorial 1-9 for the following steps.

- () Turn the circuit board foil-side-up and cutoff any excess lead lengths.
- () Install and solder a connector pin in hole TP1 on the foil side of the circuit board. NOTE: Solder may flow into the connector pin when you solder it to the foil. It is not necessary to remove the solder, as the pin is used only as a test point during calibration.

CIRCUIT BOARD CHECKOUT

Carefully inspect the circuit board for the following conditions.

- () Unsoldered connections.
- () "Cold" solder connections.
- () Protruding leads which could touch together.
- () Transistors and integrated circuits for the proper type and installation.
- () Tantalum capacitor for the correct position of the positive (+) end.
- () Diodes for the correct position of the banded end.

This completes the assembly of the circuit board. Set it aside temporarily.

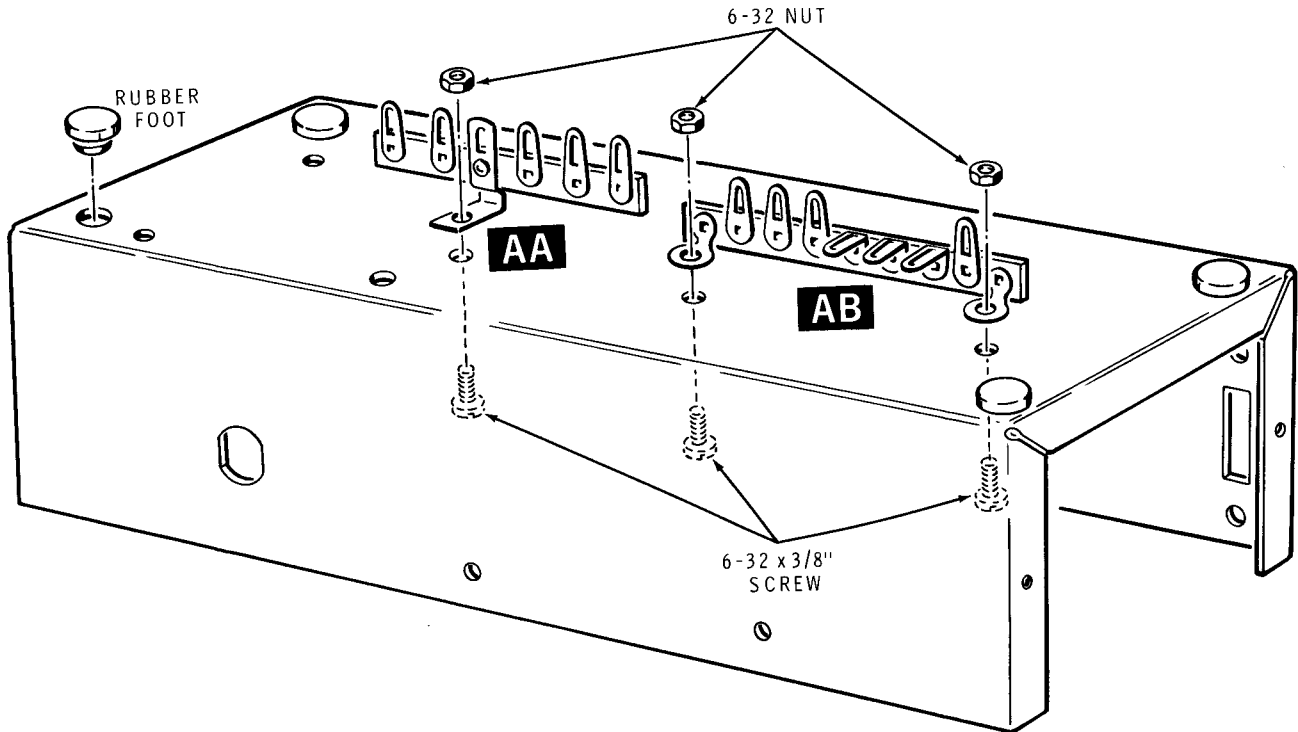

PICTORIAL 2-1

TERMINAL STRIP PREPARATION

Refer to Pictorial 2-1 for the following steps.

- ✓ Turn the chassis upside down as shown.
- ✓ Install a rubber foot in the hole at each corner of the chassis.

NOTE: Because of the limited space within the chassis, you will temporarily mount and wire the 6-lug and 7-lug terminal strips on the bottom of the chassis in the following steps. They will be removed and remounted inside the chassis later.

- ✓ Temporarily mount a 6-lug terminal strip at location AA. Use a 6-32 x 3/8" screw and a 6-32 nut.

- ✓ Refer to Detail 2-1A and bend the three indicated lugs of the 7-lug terminal strip down as shown.
- ✓ Temporarily mount the 7-lug terminal strip at location AB. Use two 6-32 x 3/8" screws and two 6-32 nuts.

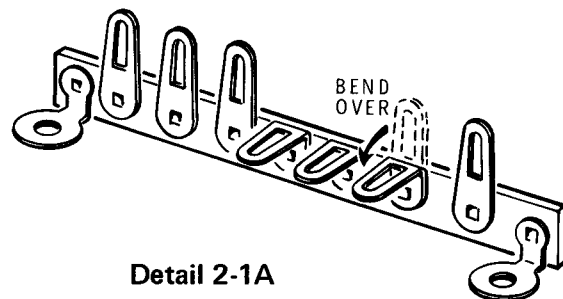

Detail 2-1A

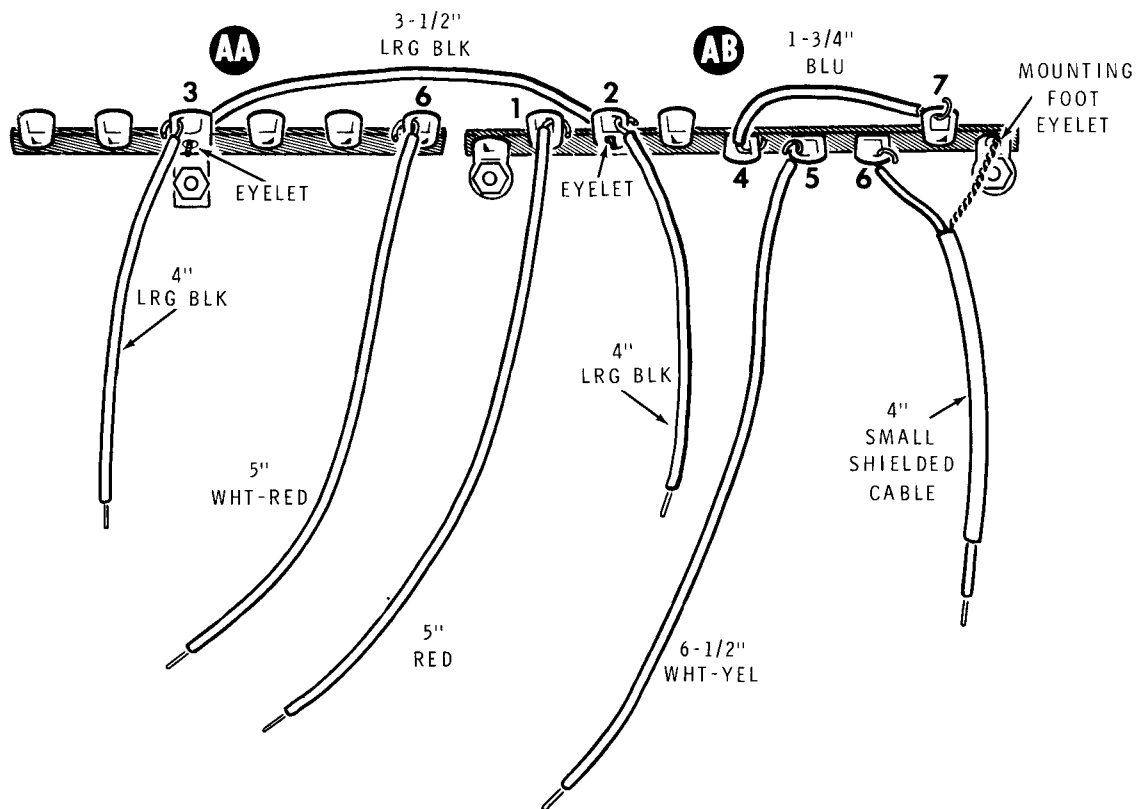

PICTORIAL 2-2

Refer to Pictorial 2-2 for the following steps.

Prepare the following wires:

- 3-1/2" large black stranded
- 4" large black stranded
- 5" white-red
- 5" red
- 4" large black stranded
- 1-3/4" blue
- 6-1/2" white-yellow

- (1) Connect a 3-1/2" large black stranded wire from terminal strip AA lug 3 (eyelet) (S-1) to terminal strip AB lug 2 (eyelet) (S-1).
- (2) Connect one end of a 4" black stranded wire to terminal strip AA lug 3 (NS). The other end will be connected later.
- (3) Connect one end of a 5" white-red wire to terminal strip AA lug 6 (NS). The other end will be connected later.
- (4) Connect one end of a 5" red wire to terminal strip AB lug 1 (NS). The other end will be connected later.
- (5) Connect one end of a 4" large black stranded wire to terminal strip AB lug 2 (NS). The other end will be connected later.
- (6) Connect a 1-3/4" blue wire to terminal strip AB between lugs 4 (NS) and 7 (NS).
- (7) Connect one end of a 6-1/2" white-yellow wire to terminal strip AB lug 5 (NS). The other end will be connected later.

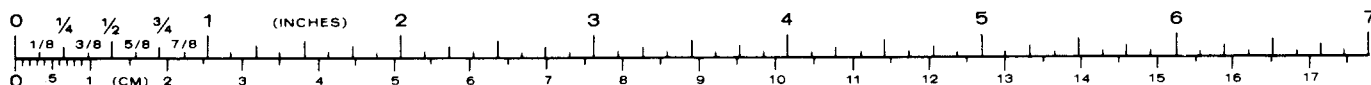

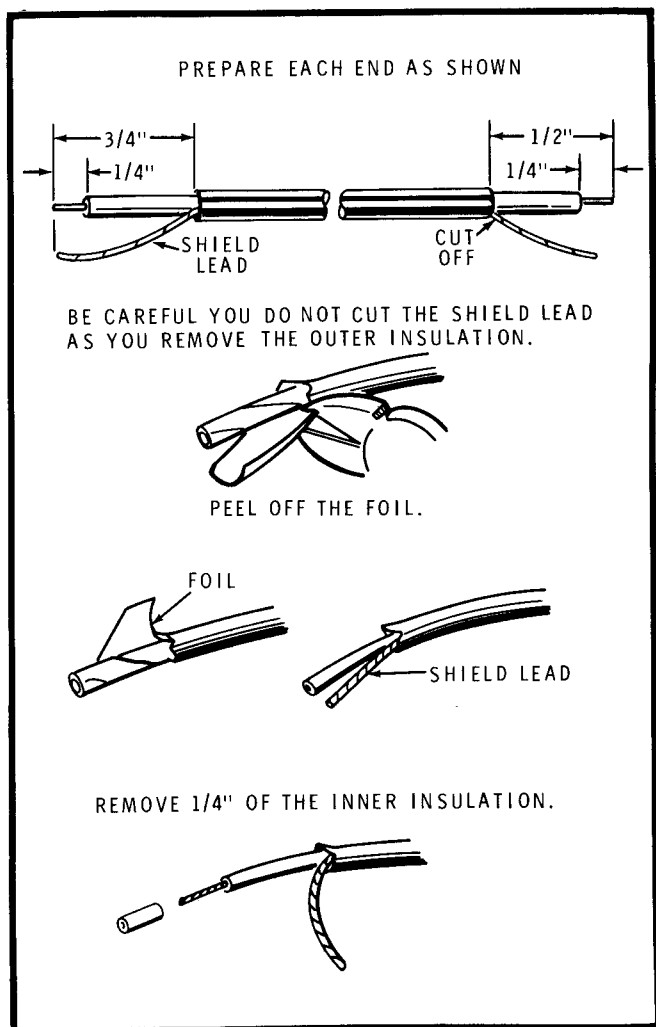

Detail 2-2A

- (✓) Refer to Detail 2-2A and prepare a 4" small shielded cable.
- (✓) Connect the inner lead at the longer prepared end of the 4" small shielded cable to terminal strip AB lug 6 (NS). Connect the shield lead to the mounting foot eyelet (S-1).

Refer to Pictorial 2-3 for the following steps.

NOTE: When you install the resistors and diodes in the following steps, position them near the terminal strips as shown in the inset drawing.

- (✓) R101: Connect a 1000 Ω (brown-black-red) resistor from terminal strip AA lug 6 (NS) to terminal strip AB lug 1 (NS).

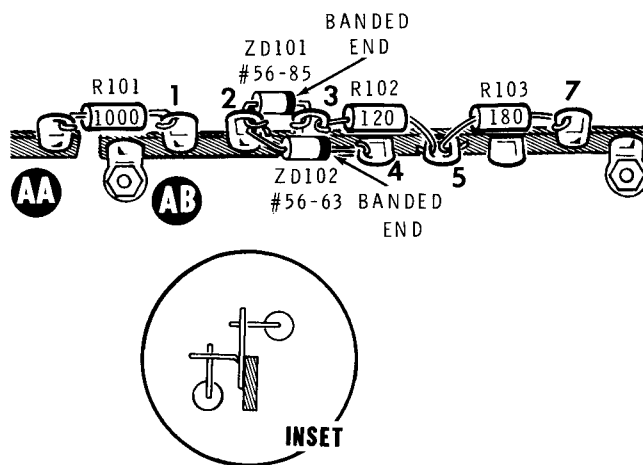

PICTORIAL 2-3

NOTE: When you install diodes in the following steps, be sure you connect the lead at the banded end (See Detail 2-3A) to the point indicated.

- (✓) ZD101: Connect the lead at the banded end of an SZ5.0 zener diode (#56-85) to terminal strip AB lug 3 (NS). Connect the other lead to terminal strip AB lug 2 (NS).
- (✓) R102: Connect a 120 Ω (brown-red-brown) resistor to terminal strip AB between lugs 3 (S-2) and 5 (NS).
- (✓) ZD102: Connect the lead at the banded end of an MZ500-10 zener diode (#56-63) to terminal strip AB lug 4 (NS). Connect the other lead to terminal strip AB lug 2 (NS).
- (✓) R103: Connect a 180 Ω (brown-gray-brown) resistor to terminal strip AB between lugs 5 (NS) and 7 (NS).

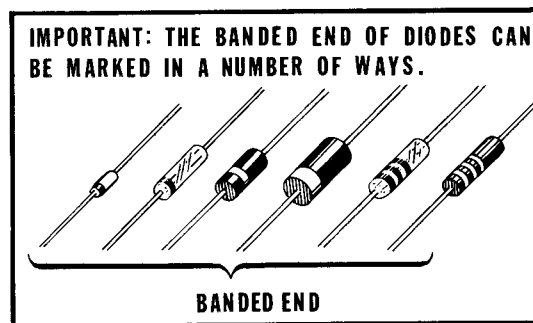

Detail 2-3A

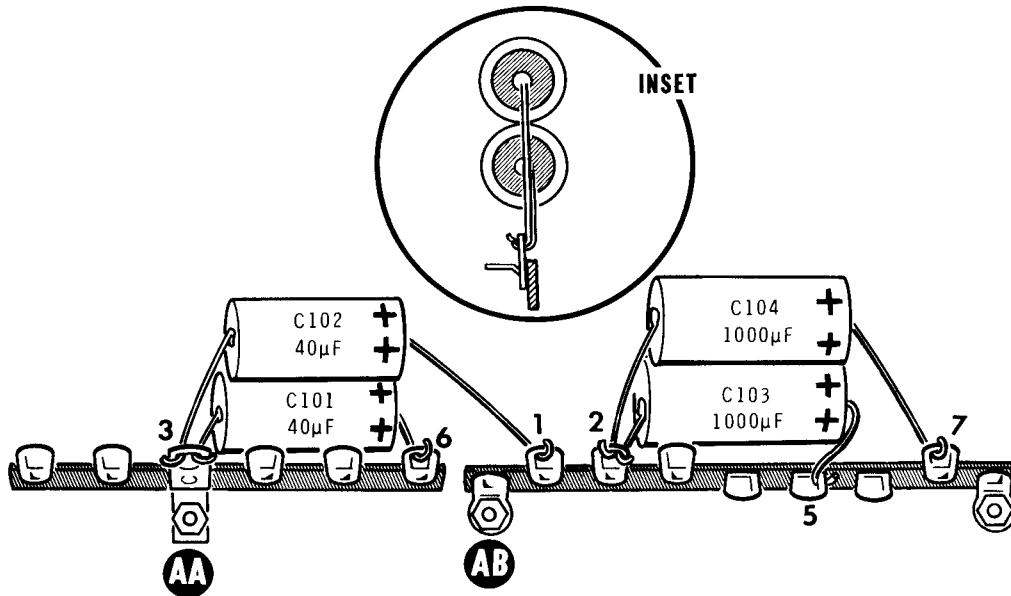

PICTORIAL 2-4

Refer to Pictorial 2-4 for the following steps.

NOTES:

1. When you install the electrolytic capacitors in the following steps, position them directly above, but not touching, the terminal strip lugs as shown in the inset drawing.
2. When several wires are connected to the lug of a terminal strip, make sure that all of them get soldered properly. It is possible to overlook a connection near the bottom of the lug.

(N) C101: Connect the lead at the positive (+) marked end of a 40 μF electrolytic capacitor to terminal strip AA lug 6 (S-3). Connect the other lead to terminal strip AA lug 3 (NS).

(N) C102: Connect the lead at the positive (+) marked end of a 40 μF electrolytic capacitor to terminal strip AB lug 1 (S-3). Connect the other lead to terminal strip AA lug 3 (S-3).

(N) C103: Connect the lead at the positive (+) marked end of a 1000 μF electrolytic capacitor to terminal strip AB lug 5 (NS). Connect the other lead to terminal strip AB lug 2 (NS).

(N) C104: Connect the lead at the positive (+) marked end of a 1000 μF electrolytic capacitor to terminal strip AB lug 7 (S-3). Connect the other lead to terminal strip AB lug 2 (S-5).

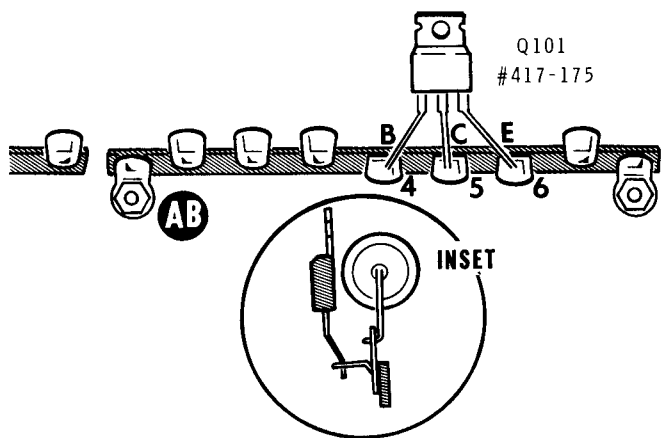

PICTORIAL 2-5

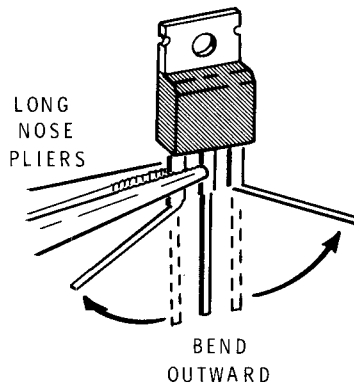

Detail 2-5A

Refer to Pictorial 2-5 for the following steps.

(✓) Refer to Detail 2-5A and grasp the outside leads of a 2N5294 transistor (#417-175) with long-nose pliers. Then carefully bend them outward as shown.

(✓) Q101: Connect the 2N5294 transistor (#417-175) to terminal strip AB as follows:

Base (B) lead to lug 4 (S-3).

Collector (C) lead to lug 5 (S-5).

Emitter (E) lead to lug 6 (S-2).

(✓) Refer to the inset drawing and push the transistor back against the electrolytic capacitors.

(✓) Remove terminal strips AA and AB from the bottom of the chassis and carefully set them aside. Save the screws and nuts, as they will be used again.

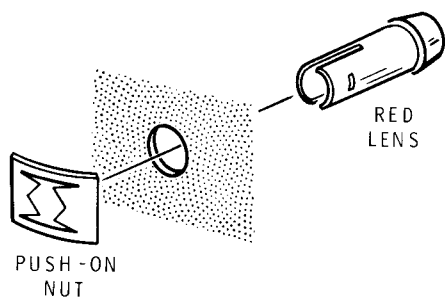

Detail 2-6A

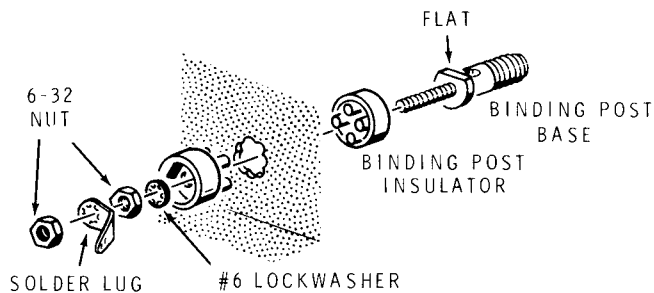

Detail 2-6D

CHASSIS PARTS MOUNTING

Refer to Pictorial 2-6 in the Illustration Booklet for the following steps.

() Refer to Detail 2-6A and install a red lens at PL101 with a push-on nut. Push the nut all the way onto the lens.

() PL101: Refer to Detail 2-6B in the Illustration Booklet and install a neon lamp and a terminal collar on the lens at PL101.

() SW101: Refer to Detail 2-6C and mount a 2-position slide switch at SW101. Use 6-32 x 3/8" screws. Position the switch as shown in the Pictorial.

() Refer to Detail 2-6D and install binding posts at AC and AD as follows:

1. Place a binding post insulator in the hole. Position the insulator so the flat is parallel with the bottom edge of the chassis.
2. Insert a binding post base into the insulator. Make sure the flat on the base lines up with the flat in the insulator.
3. Install another binding post insulator, a #6 lockwasher, and a 6-32 nut on the binding post base. Use long-nose pliers to tighten the nut.
4. Install a #6 solder lug and 6-32 nut on the binding post base. Position the solder lug as shown in the Pictorial.

() Refer to Detail 2-6E and install a rubber grommet in hole AE.

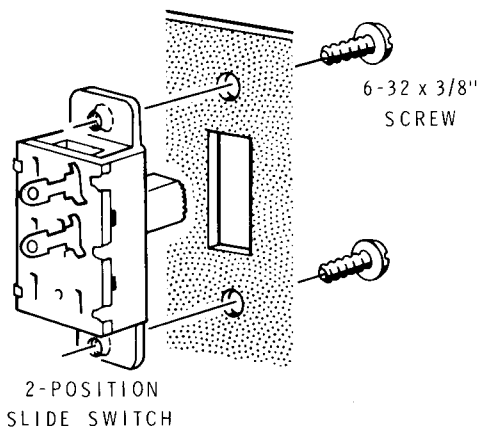

Detail 2-6C

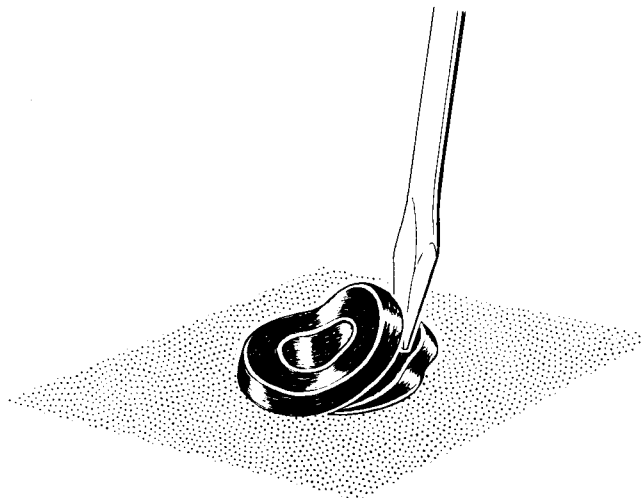

Detail 2-6E

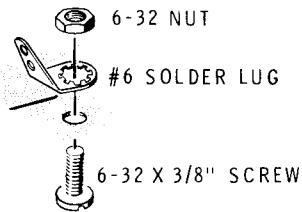

Detail 2-6F

✓) Refer to Detail 2-6F and install a #6 solder lug at AL with a 6-32 x 3/8" screw, and 6-32 nut. Position the solder lug as shown. NOTE: Scrape away any paint overspray from around the hole on the inside of the chassis before you install this hardware.

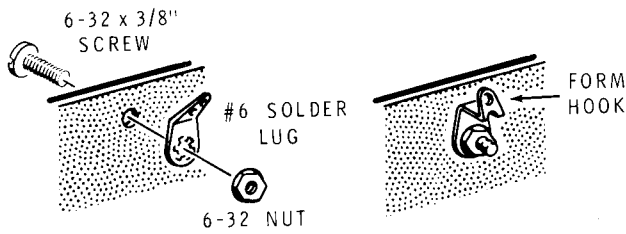

Detail 2-6G

✓) Refer to Detail 2-6G and install #6 solder lugs at AH and AJ with 6-32 x 3/8" screws and 6-32 nuts. Position the solder lugs as shown in the Pictorial. Then bend the end of each lug to form a hook as shown. Make sure the end of the lug is below the edge of the chassis.

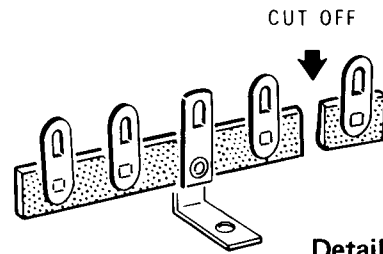

Detail 2-6H

✓) Refer to Detail 2-6H and cut off the indicated lug of the 5-lug terminal strip to form a 4-lug terminal strip.

✓) T101: Refer to Detail 2-6J and mount the power transformer at T101. Use a 6-32 x 3/8" screw, two #6 lockwashers, and a 6-32 nut at AG. Use a 6-32 x 3/8" screw, three #6 lockwashers, a 4-lug terminal strip, and a 6-32 nut at AF as shown. Position the transformer and terminal strip as shown in the Pictorial.

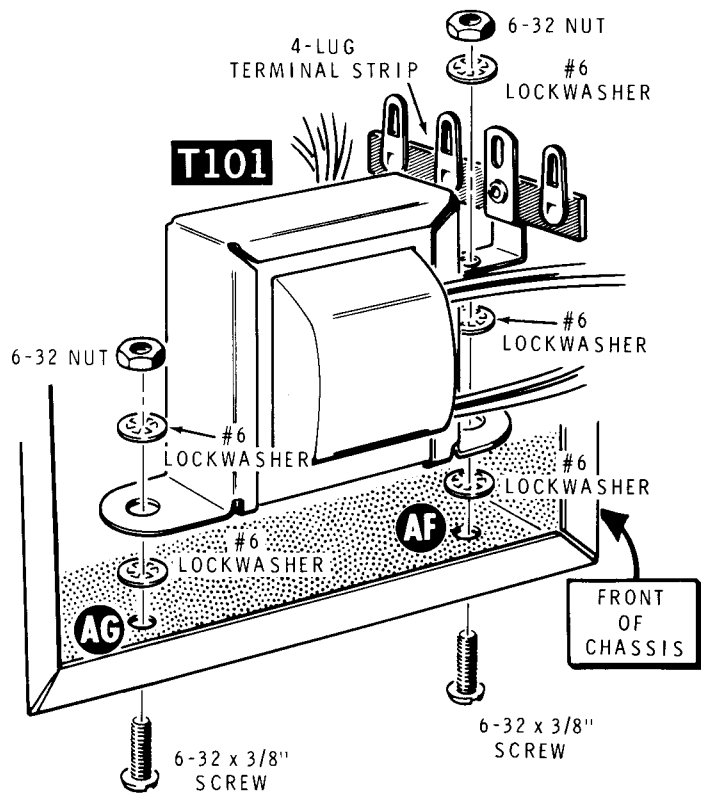

Detail 2-6J

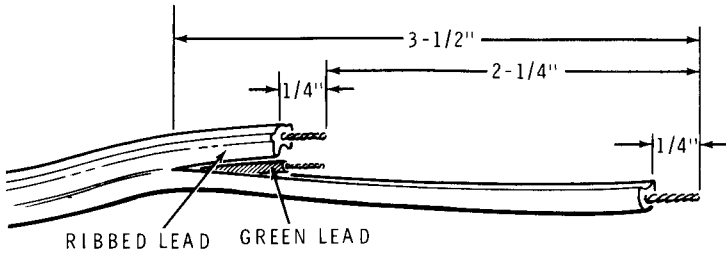

Detail 2-7A

CHASSIS WIRING

Refer to Pictorial 2-7 in the Illustration Booklet for the following steps.

- (A) Refer to Detail 2-7A and separate the ends of the line cord approximately 3-1/2". Examine the outer insulation of the line cord and notice that one side is smooth and the other has a rib (or ribs) along it. Cut off 2-1/4" from the end of the ribbed lead and the end of the green lead. Remove 1/4" of insulation from the end of each lead. Tightly twist the wire ends and add a small amount of solder to each lead to hold the small strands together.
- (B) Pass the end of the line cord through hole AK in the rear panel of the chassis.
- (C) Refer to Detail 2-7B and install a strain relief on the line cord 4-1/2" from the end. Then mount it in the chassis at AK.

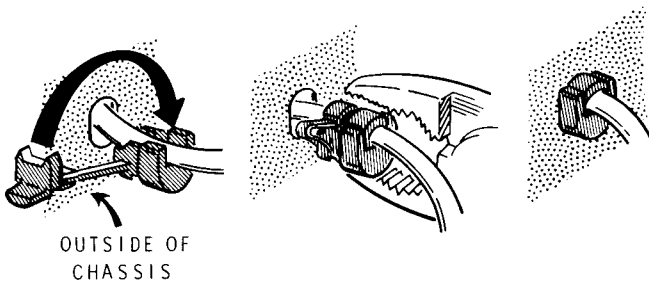

Detail 2-7B

NOTE: In some of the following steps you will be instructed to "make a mechanically secure connection." To do this, insert the wire through the lug or terminal and wrap it around the lug or terminal before you solder the connection. See inset drawing #1 on Pictorial 2-7.

- (D) Connect the green lead of the line cord to solder lug AL (S-1). Make a mechanically secure connection.
- (E) Connect the smooth lead of the line cord to terminal strip AF lug 4 (NS). Make a mechanically secure connection.
- (F) Refer to Detail 2-7C and mount the previously assembled terminal strips in the chassis at AA and AB. Use three 6-32 x 3/8" screws, six #6 lockwashers, and three 6-32 nuts.
- (G) Route a tie around capacitors C101 and C102 and over the hook in solder lug AH. Insert the pointed end of the tie through the locking collar and pull it tight around the capacitors as shown in inset drawing #2 of Pictorial 2-7. Cut off the excess tie.
- (H) Likewise, install a tie around capacitors C103 and C104, and over the hook in solder lug AJ.
- (I) Route the black-yellow transformer lead around the transformer and connect it to terminal strip AA lug 1 (NS). Make a mechanically secure connection.
- (J) Route the black-red transformer lead around the transformer and connect it to terminal strip AA lug 2 (NS). Make a mechanically secure connection.
- (K) Connect the black-green transformer lead to terminal strip AF lug 3 (NS). Make a mechanically secure connection.
- (L) Connect the black transformer lead to terminal strip AF lug 1 (NS). Make a mechanically secure connection.
- (M) Connect the ribbed lead of the line cord to terminal strip AA lug 2 (NS). Make a mechanically secure connection.

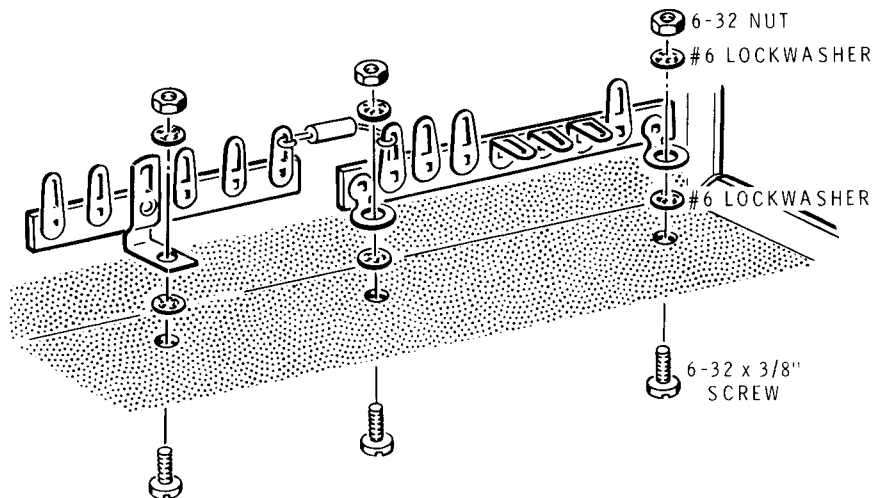

Detail 2-7C

(1) Prepare the following wires:

1-3/4" black stranded

5" black stranded

(2) Refer to Detail 2-7D and slide a switch insulator onto the lugs of switch SW101. NOTE: If the lugs are in the center of the switch, discard the insulator; if is not required on this type of switch.

(3) Connect a 1-3/4" black stranded wire from switch SW101 lug 1 (NS) to terminal strip AF lug 1 (NS). Make mechanically secure connections.

(4) Connect a 5" black stranded wire from terminal strip AA lug 1 (NS) to pilot lamp PL101 lug 2 (S-2). Make a mechanically secure connection.

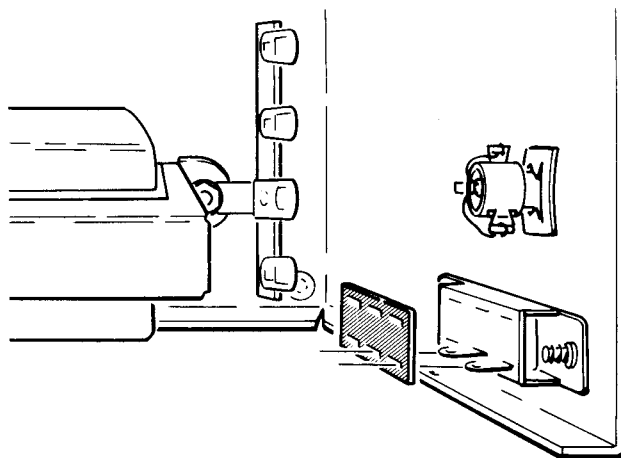

Detail 2-7D

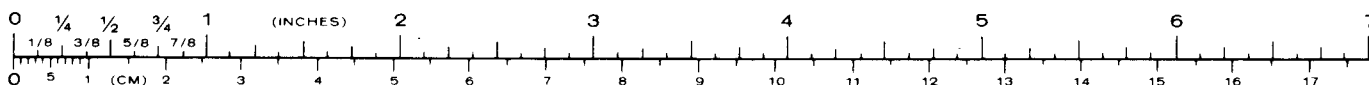

ALTERNATE LINE VOLTAGE WIRING

Two sets of line voltage wiring instructions are given below, one for 120 VAC line voltage and one for 240 VAC line voltage. In the U.S.A., 120 VAC is most often used, while in the other countries 240 VAC is more common. USE ONLY THE INSTRUCTIONS THAT AGREE WITH THE LINE VOLTAGE IN YOUR AREA.

120 VAC Wiring

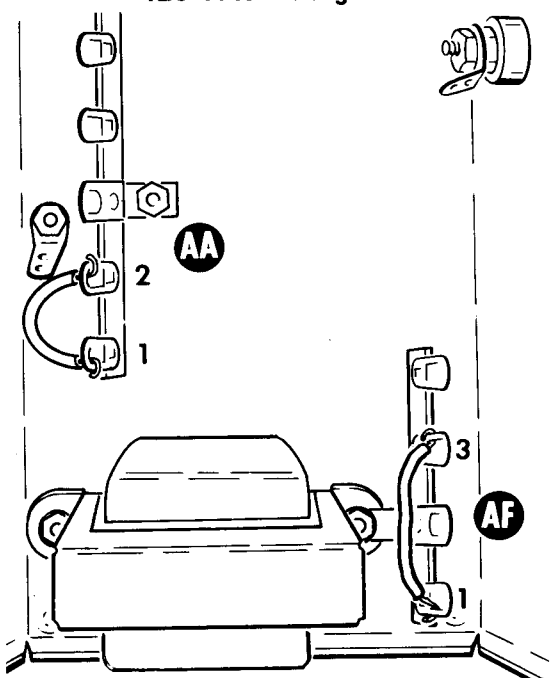

Detail 2-7E

Refer to Detail 2-7E for the following steps.

() Prepare the following wires:

- 1-3/4" black stranded
- 1-3/4" black stranded

() Connect a 1-3/4" black stranded wire to terminal strip AA between lugs 1 (S-3) and 2 (S-3). Make a mechanically secure connection.

() Connect a 1-3/4" black stranded wire to terminal strip AF between lugs 1 (S-3) and 3 (S-2). Make a mechanically secure connection.

240 VAC Wiring

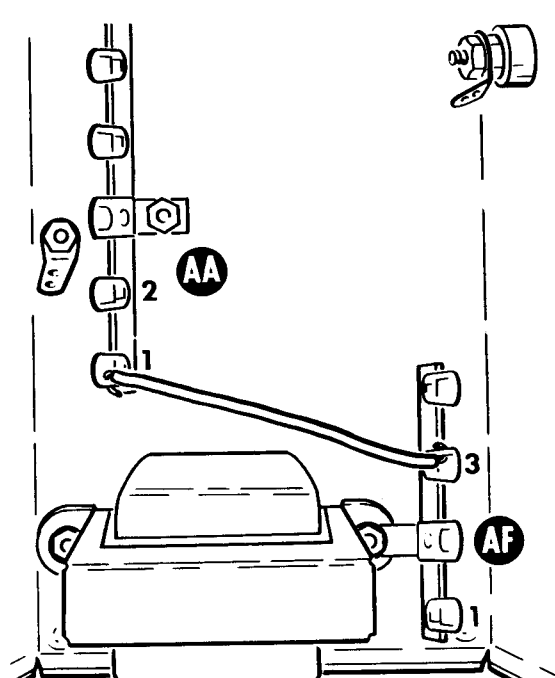

Detail 2-7F

Refer to Detail 2-7F for the following steps.

() Prepare a 3" black stranded wire.

() Connect the 3" black stranded wire from terminal strip AA lug 1 (S-3) to terminal strip AF lug 3 (S-2). Make a mechanically secure connection.

() Solder the wires at terminal strip AA lug 2 (S-2).

() Solder the wires at terminal strip AF lug 1 (S-2).



CHASSIS WIRING-Continued

Refer to Pictorial 2-8 in the Illustration Booklet for the following steps.

- () R105: Connect a 27 k Ω (red-violet-orange) resistor from pilot lamp PL101 lug 1 (S-2) to switch SW101 lug 1 (S-2).
- () Place the 1-1/2" length of large clear sleeving over the 3/16-ampere fuse.
- () F101: Connect the 3/16-ampere slow-blow fuse from terminal strip AF lug 4 (S-2) to switch SW101 lug 2 (S-1). Make sure the fuse leads do not touch any other lugs or parts.
- () Write "3/16-ampere slow-blow" in the blank space provided on the fuse label. Then peel the paper backing from the label and press it in place above the line cord in the chassis.
- () Position the free ends of all wires coming from terminal strips AA and AB over the back of the chassis and out of the way.
- () Place the previously assembled circuit board in the chassis as shown in the Pictorial. Insert the free end of the large shielded cable, coming from circuit board holes BB and CC, through grommet AE. NOTE: Since grommet AE serves as a strain relief for the large shielded cable, the cable will not slide easily through the grommet. Therefore, use your fingers to apply a soapy solution (either liquid or bar type soap will do) to the cable to make it slide through the grommet. Then wipe off the excess soap.

Connect the transformer leads to the circuit board as follows:

- () Short yellow lead to hole L (S-1).
- () Long yellow lead to hole K (S-1).
- () Either red lead to hole H (S-1).
- () Other red lead to hole G (S-1).
- () Connect the inner lead of the small shielded cable coming from switch SW2 to solder lug AC (S-1).
- () Connect the large black stranded wire coming from circuit board hole R to solder lug AD (S-1).

Refer to Pictorial 2-9 in the Illustration Booklet for the following steps.

NOTE: When you connect the following wires to the foil side of the circuit board, leave the insulation 1/8" away from the foil so that solder can flow around the bare wire end. See the inset drawing.

- () Reposition the circuit board as shown.

Connect the wires coming from terminal strip AA to the foil side of the circuit board as follows:

- () Large black wire coming from lug 3 to hole C (S-1).
- () White-red wire coming from lug 6 to hole B (S-1).

Connect the wires coming from terminal strip AB to the foil side of the circuit board as follows:

- () Red wire coming from lug 1 to hole D (S-1).
- () Large black wire coming from lug 2 to hole E (S-1).
- () White-yellow wire coming from lug 5 to hole A (S-1).
- () Inner lead of the small shielded cable coming from lug 6 to hole LL (S-1).

Refer to Pictorial 2-10 for the following steps.

- () Mount the circuit board to the front of the chassis as shown. Position switch SW102 so the lug with the white-red wire is on top. Then mount switch SW102 to the chassis with two 6-32 x 3/8" screws. Install control flat washers and control nuts on switches SW1 and SW2.

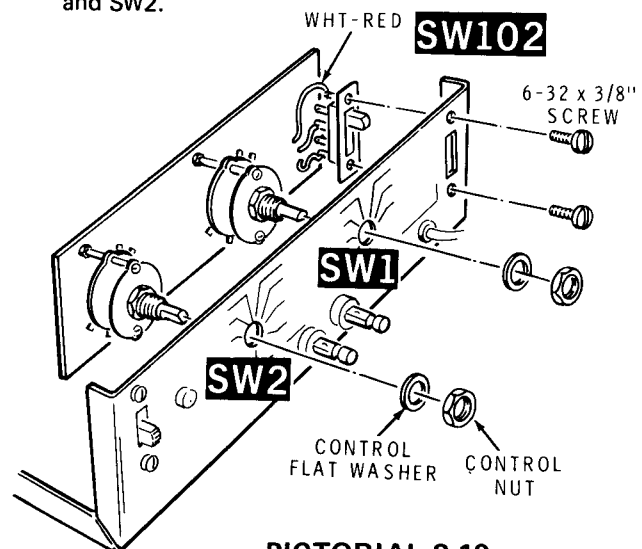

PICTORIAL 2-10

CABLE PREPARATION

Refer to Pictorial 2-11 in the Illustration Booklet and the indicated Details for the following steps.

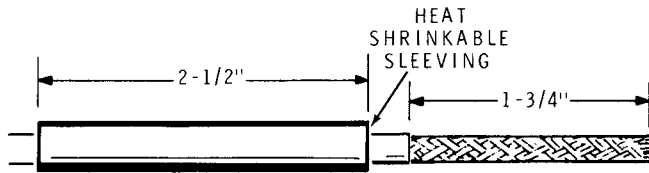

Detail 2-11A

Refer to Detail 2-11A and:

1. () Slide a 2-1/2" length of heat shrinkable sleeving onto the free end of the large shielded cable.
2. () Carefully remove 1-3/4" of outer insulation.

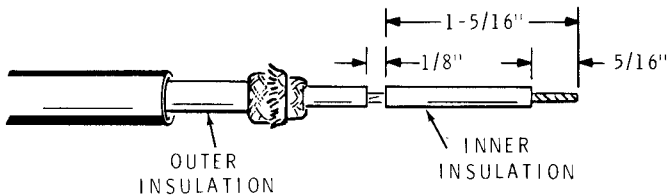

Detail 2-11B

Refer to Detail 2-11B and:

1. () Push the braided shield wires back over the outer insulation.
2. () Remove 5/16" of insulation from the end of the inner lead. Then apply a small amount of solder to the bare wire ends.
3. () Measure 1-5/16" from the end of the cable and carefully remove 1/8" of insulation.

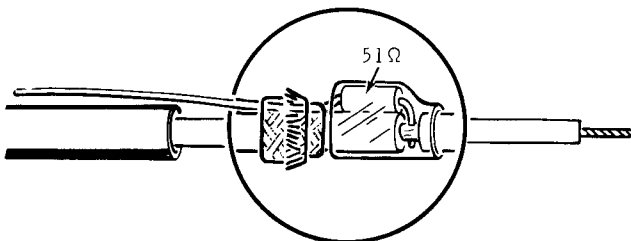

Detail 2-11C

Refer to Detail 2-11C and:

1. () Insert one lead of a 51 Ω (green-brown-black), 1/4-watt resistor through the braided shield wires.

2. () Wrap the other lead around the inner lead of the shielded cable and solder the connection. Keep the resistor as close to the inner lead as possible. Cut off the excess lead length.

3. () Slide a 1/2" length of small clear sleeving over the resistor and inner lead as shown.

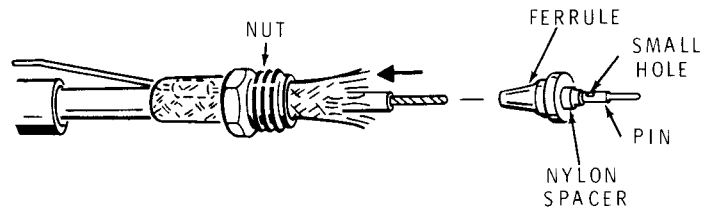

Detail 2-11D

Refer to Detail 2-11D and:

1. () Pull the braided shield wires back over the resistor to their original position.
2. () Slide the BNC nut over the shield wires onto the end of the cable.
3. () Push the braided shield wires back enough to expose the end of the inner lead.
4. () Push the BNC pin (this includes the ferrule and the nylon spacer) onto the end of the inner lead. Solder the pin to the inner lead. To do this, position the pin so the small hole faces upward. Then hold your soldering iron against the under side of the pin and apply a small amount of solder into the small hole. Do not allow solder to accumulate on the outside of the pin.

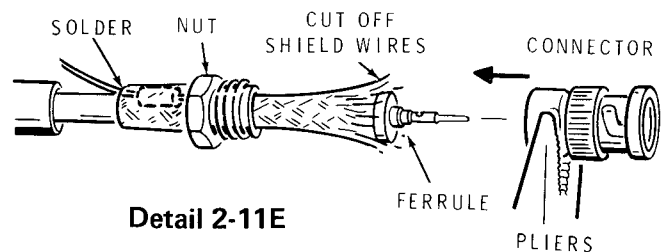

Detail 2-11E

Refer to Detail 2-11E and:

1. () Pull the braided shield wires over the ferrule. Then cut off the shield wires that extend beyond the sides of the ferrule.
2. () Push the connector onto the pin until it seats against the nylon spacer.

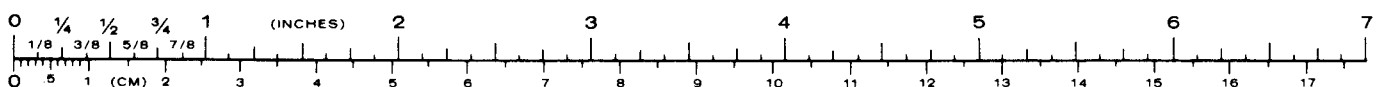

- 3. () Grasp the connector with long-nose pliers. Slide the nut into the connector and turn the nut until it is tight.
- 4. () Solder the resistor to the shield wires and cut off the excess lead lengths.
- () Grasp the bushings just installed and turn switches SW1 and SW2 fully clockwise.
- () Refer to Detail 2-11H and install a knob on switch SW1. Line up the pointer with the 1- μ S mark on the front panel.

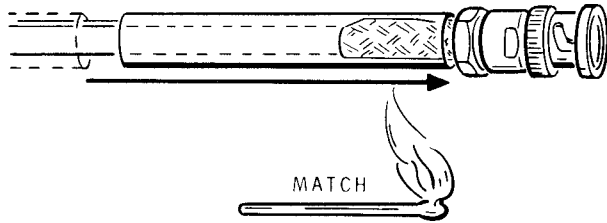

Detail 2-11F

Refer to Detail 2-11F and:

- 1. () Slide the 2-1/2" length of heat shrinkable sleeving up against the nut.
- 2. () Use the heat from a match to shrink the sleeving. Turn the cable to shrink the sleeving evenly.

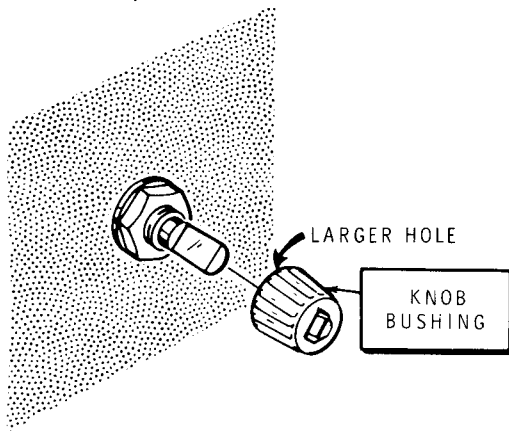

Detail 2-11G

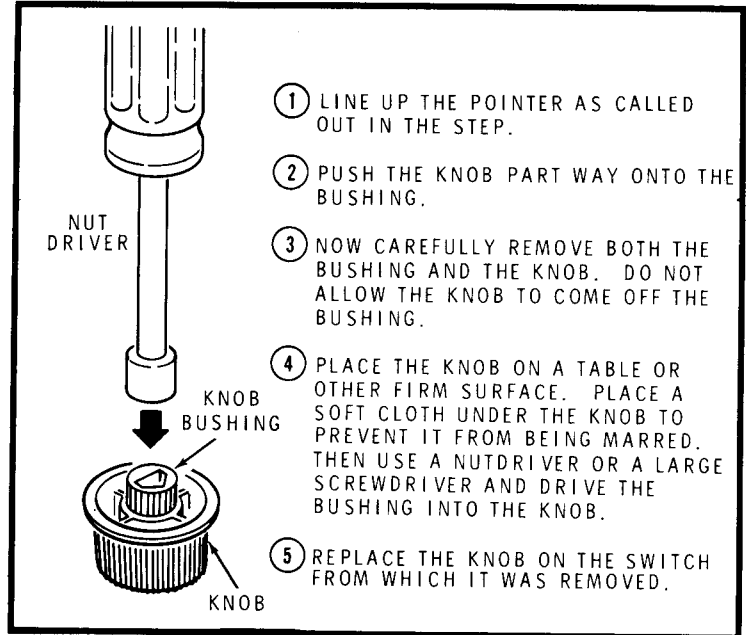

Detail 2-11H

- () Refer to Detail 2-11H and install a knob on switch SW2. Line up the pointer with the GND mark on the front panel.
- () Install a red binding post cap on the binding post at AC.
- () Install a black binding post cap on the binding post at AD.
- () Carefully peel the backing paper from the blue and white identification label. Then press the label onto the outside of the rear panel as shown in the inset drawing.

NOTE: The blue and white identification label shows the model number and production series number of your kit. Refer to these numbers in any communications with the Heath Company; this assures you that you will receive the most complete and up-to-date information in return.

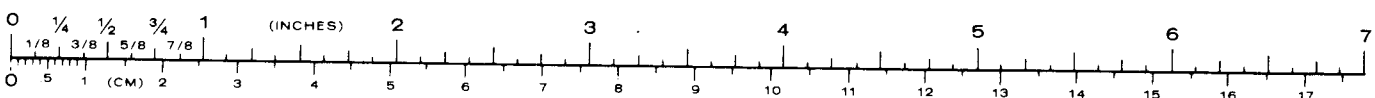

KNOB INSTALLATION

Refer to Pictorial 2-11 in the Illustration Booklet for the following steps.

Examine the knob bushings before you perform the following steps. Notice that the triangular hole is larger at one end of the bushing than the other. Always start at the end of the bushing with the larger hole onto the switch shaft.

- () Refer to Detail 2-11G and push knob bushings onto the shafts of switches SW1 and SW2.

TESTS AND CALIBRATION

In this section of the Manual you will test and calibrate your Oscilloscope Calibrator. If at any time you do not obtain the results indicated, refer to the "In Case of Difficulty" section on Page 39. Locate and repair any problems before you continue with the calibration.

- () Carefully inspect all connections for loose wires or unsoldered connections. Remove any clippings or solder splashes.

TESTS

- () Set the calibrator front panel switches as follows:

POWER (SW101) – OFF

VOLTS OUT (SW2) – 1V

TIME OUT (SW1) – 1mS

MULTIPLIER (SW102) – X1

- () Set the CAL control R14 (located on the circuit board) to the center of rotation.

WARNING: When the line cord is connected to an AC outlet, AC voltage is present at several places. These areas are shown in the boxed-in area on Figure 1-1 in the Illustration Booklet. Be careful – you may receive a severe electrical shock if you touch this voltage.

- () Connect the calibrator line cord plug to an AC outlet.

- () Set your oscilloscope controls as follows:

INPUT ATTENUATOR – .5V/cm

TIME BASE – 1mS/cm

- () Connect the BNC connector to the input of your oscilloscope.

- () Slide the POWER switch to the ON position.

- () Adjust the trigger and stability control on your oscilloscope to obtain a waveform similar to the waveform in Figure 1-2.

- () Turn the TIME OUT and MULTIPLIER switches through each of their positions. You should obtain a waveform for each switch position. Readjust your oscilloscope time base controls as necessary.

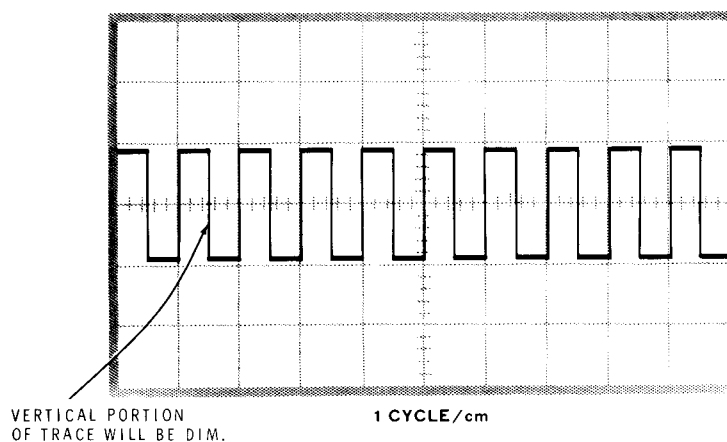

Figure 1-2

- () Disconnect the BNC connector from the input of your oscilloscope.
- () Set the Calibrator TIME OUT switch to the 1 mS position.
- () Place the MULTIPLIER switch in the X1 position.
- () Set your oscilloscope time base to 1 mS/cm.
- () Connect oscilloscope test lead from the input of the oscilloscope to the VOLTS OUT binding posts.
- () Turn the VOLTS OUT switch through each of its positions. You should obtain a waveform similar to the waveform in Figure 1-2. The signal amplitude, however, will reflect the setting of the VOLTS OUT switch. Readjust the input attenuator of your oscilloscope as necessary. **WARNING:** To avoid a possible shock, do not touch the Volts Out signal when the VOLTS OUT switch is in the 100V position.
- () Disconnect the oscilloscope leads from the Calibrator.
- () Refer to Figure 1-3 in the Illustration Booklet and adjust the CAL control R14 for exactly 1.000 volts DC on the DVM.
- () Disconnect the DVM test leads.
- () Slide the POWER switch to the OFF position.
- () Unplug the line cord from the AC outlet.

Proceed to "Final Assembly."

Using an Analog Voltmeter

Set the Calibrator front panel switches as follows:

VOLTS OUT – 1V

TIME OUT – DC

MULTIPLIER – X1

CALIBRATION

The Oscilloscope Calibrator can be calibrated with either a DVM (digital voltmeter) or an analog voltmeter. The DVM provides the greatest accuracy (usually greater than 1%). Proceed to the method, either "Using a DVM" or "Using an Analog Voltmeter," that you are going to use.

Using a DVM

- () Set the calibrator front panel switches as follows:
 - VOLTS OUT – 1V
 - TIME OUT – DC
 - MULTIPLIER – X1
- () Slide the POWER switch to the ON position.
- () Connect the DVM test leads to the VOLTS OUT binding posts.
- () Slide the POWER switch to the ON position.
- () Set the voltmeter to measure +5 volts DC.
- () Connect the voltmeter ground lead to the black VOLTS OUT binding post.
- () Measure the voltage at TP2 (on terminal strip AB lug 3). See Figure 1-3 in the Illustration Booklet. Notice and remember the exact meter indication.
- () Measure the voltage at TP1 (on the foil side of the circuit board). Adjust the CAL control R14 for the same meter indication you obtained at TP2 in the previous strip.
- () Repeat the two previous steps several times to obtain an accurate adjustment.
- () Disconnect the test leads.
- () Slide the POWER switch to the OFF position.
- () Unplug the line cord plug from the AC outlet.

Proceed to "Final Assembly."

FINAL ASSEMBLY

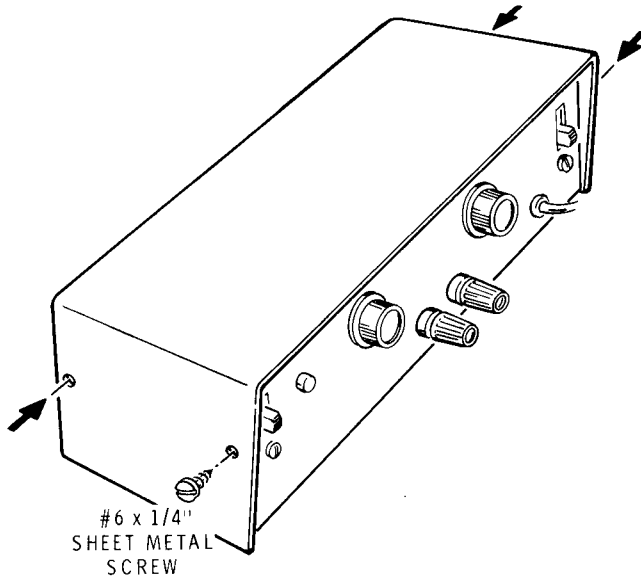

PICTORIAL 3-1

Refer to Pictorial 3-1 for the following step.

- () Install the cabinet shell on the chassis with the sloping edge toward the front. Use #6 x 1/4" sheet metal screws.

This completes the "Final Assembly" of your Oscilloscope Calibrator. Proceed to the "Operation" section for operating instructions.

OPERATION

Figure 2-1 in the Illustration Booklet shows the front panel of the Calibrator. Study this Figure carefully to become familiar with each switch and binding post.

The Oscilloscope Calibrator provides both the accurate time and amplitude signals needed to calibrate Heathkit Oscilloscopes, as well as most other oscilloscopes. An output cable with its own built-in termination assures good frequency response. The Calibrator is also quite useful as a bench standard. Use it to calibrate other test equipment or as a signal source when you build and test experimental circuits.

TIME OUTPUT SIGNAL

The Calibrator provides 18 accurate fast-rise output signals from .5 S (2 Hz) to 1 μ S (1 MHz) in a 1-2-5 sequence. The 1-2-5 sequence of the output signal is obtained from the three positions of the MULTIPLIER switch (X1, X2, X5). This means that each setting of the TIME OUT switch has three outputs in a 1-2-5 sequence. Because the rise time of these signals is less than 4 nanoseconds, they are well suited for making high frequency compensation adjustments on oscilloscope vertical amplifiers. Oscilloscope time base adjustments can also be made using these signals. The amplitude of this signal is approximately 200 millivolts.

The actual period of the TIME OUT output signal is obtained when you multiply the TIME OUT switch setting by the MULTIPLIER switch setting. For example, a TIME OUT switch setting of .1 ms and a MULTIPLIER switch setting of X2 provides an output signal of .2 ms.

$$.1 \text{ ms} \times 2 = .2 \text{ ms}$$

Even though these signals are indicated as a time (or period) signal, they can be easily converted to a frequency using the formula $f = 1/t$. For example, a signal with a period of .2 ms is also a 5000 Hz signal.

$$f = \frac{1}{t} = \frac{1}{.2\text{mS}} = \frac{1}{.0002} = 5000 \text{ Hz}$$

The output cable has its own 50 Ω termination. Therefore, do not use a separate 50 Ω terminator on the end of the output cable.

Because the components in most oscilloscope vertical amplifiers have a rather short time constant (as compared to the vertical attenuators), use a high frequency square wave signal (1 μ S) to make vertical amplifier compensation adjustments. The optimum overall high frequency response of an oscilloscope vertical amplifier occurs when it can display a square wave signal that has a fast rise time without excessive overshoot. The 1 μ S (1 MHz) TIME OUT signal is best suited for this purpose. Adjust the appropriate vertical amplifier compensation control to "fill-in" the leading corner of the square wave to obtain the squarest corner, flattest top, and the steepest leading edge. See Figure 2-2.

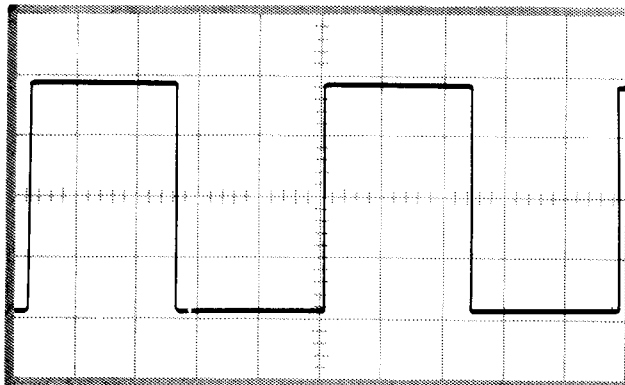

Figure 2-2

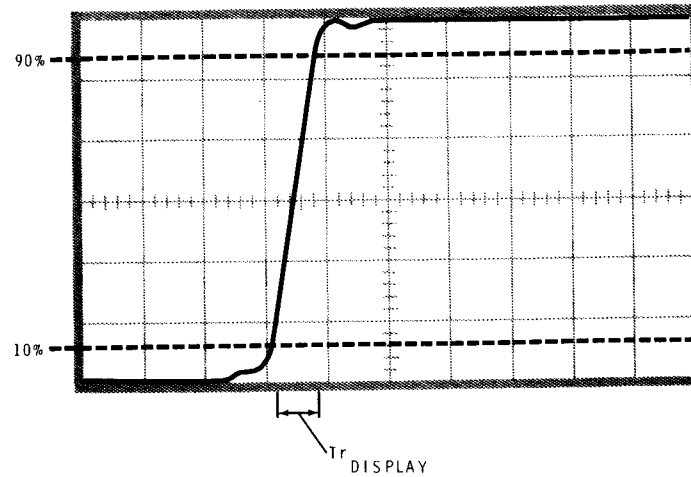

Figure 2-3

You can also use the calibrator to measure the rise time of most oscilloscopes as shown in Figure 2-3. Rise time T_r is defined as the time required for the trace to move from 10% to 90% of the total waveform. This measurement is usually made with the $1 \mu s$ (1 MHz) signal from the calibrator and the fastest sweep speed of your oscilloscope (including any sweep magnifier if it has this feature).

However, if your oscilloscope has sufficient bandwidth ≈ 35 MHz (where the rise time is less than 10 ns), the inherent rise time of the calibrator signal becomes a significant factor. In which case you should use the formula

$$T_{r \text{ scope}} = \sqrt{(T_{r \text{ display}})^2 - (4 \text{ ns})^2}$$

The 4 ns is the rise time of the calibrator signal.

The bandwidth of most oscilloscopes can be determined from the formula $BW \approx = \frac{.35}{T_r}$

where BW is expressed in MHz and T_r is expressed in ns.

NOTE: When you make rise time measurements, always keep the vertical attenuator in its calibrated position. Otherwise, the measurement may not be accurate.

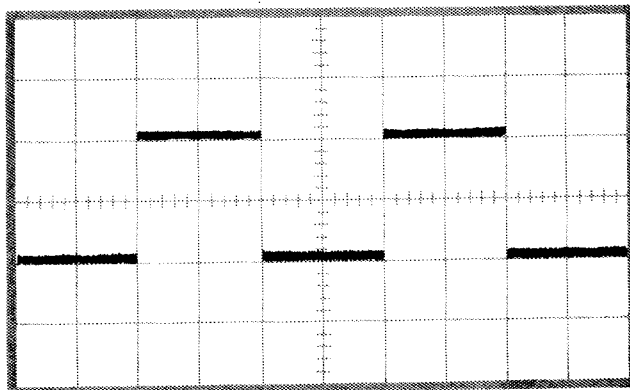
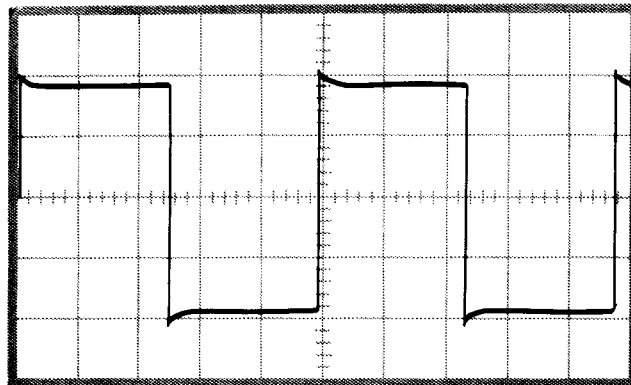

Figure 2-4

VOLTAGE OUTPUT SIGNAL

The repetition rate (period) of the VOLTS OUT signal is also set by the TIME OUT and MULTIPLIER switch settings. The 1 ms (1000 Hz) output is best suited for oscilloscope vertical input attenuator and probe compensation. Since the VOLTS OUT signal has a slower rise time than the TIME OUT signal, it is not meant to be a high frequency signal. Also, since the Volts Out circuits have a rather low frequency response, a VOLTS OUT signal may not appear or may be distorted when you select the 10 μ s and 1 μ s positions of the TIME OUT switch.

Steady state DC voltages are available from the VOLTS OUT binding posts when the TIME OUT switch is in the DC position. These are only reference voltages and they should not be used as power supply voltages. A small amount of hash (noise) will appear on the 1 mV signal; this is normal. See Figure 2-4.



A

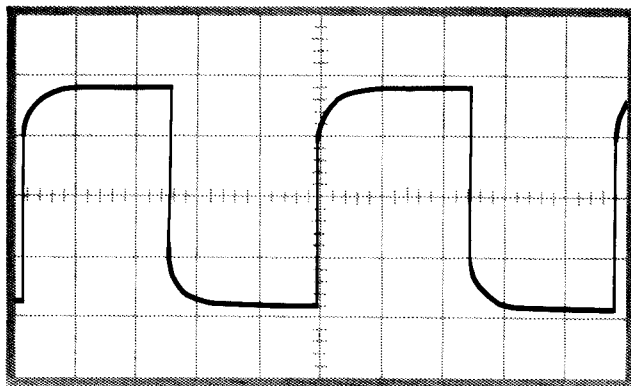

B

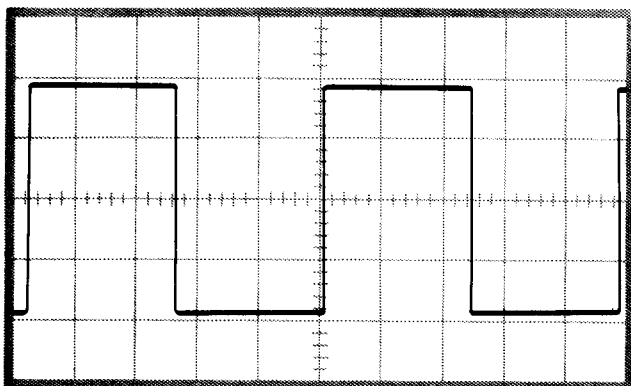

C

Figure 2-5

Since the components in most oscilloscope vertical input attenuators have a rather long time constant (as compared to the vertical amplifier circuits), use a lower frequency square wave signal (1 ms) to make vertical attenuator compensation adjustments. Also, an adjustable amplitude signal is needed for the various attenuator ranges, especially the highly attenuated ranges. Therefore, use the 1 ms (1000 Hz) VOLTS OUT signal from the Calibrator when you make vertical attenuator compensation adjustments.

When you make vertical attenuator compensation adjustments on an oscilloscope, set the TIME OUT switch to

the 1 ms position and the MULTIPLIER switch to X1. Set the VOLTS OUT switch to obtain a trace approximately 4-5 cm high. You will encounter one of three waveforms. Parts A, B, and C of Figure 2-5 show the conditions of too much compensation, too little compensation, and the correct amount of compensation respectively. Adjust the appropriate trimmer capacitors in the vertical attenuator to obtain the waveform shown in Part C.

NOTE: Make sure the oscilloscope vertical gain is in its calibrated position when you make vertical attenuator compensation adjustments.

IN CASE OF DIFFICULTY

This part of the Manual provides you with information that will help you locate and correct difficulties which might occur in your Oscilloscope Calibrator. This information is divided in various sections. The first section, "General," contains suggestions of a general nature in the following areas:

Visual check and inspection.

Precautions to observe when bench testing.

The second section, "Troubleshooting," contains a series of three test charts:

TEST #1 — If the Calibrator is completely inoperative.

TEST #2 — If the TIME OUT function is inoperative.

TEST #3 — If the VOLTS OUT function is inoperative.

Start your troubleshooting procedure by first reading the following "General" section. Then proceed to the appropriate Test.

General

Visual Checks

1. About 90% of the kits that are returned for repair do not function properly due to poor soldering. Therefore, you can eliminate many troubles by a careful inspection of connections to make sure they are soldered as described in the Soldering section of the "Kit Builders Guide." Reheat any doubtful connections and be sure all the wires are soldered at places where several wires are connected. Check carefully for solder bridges between circuit board foils.
2. Check to be sure that all transistors are in their proper locations, and are installed correctly.
3. Check the value of each part. Be sure that the proper part has been wired into the circuit, as shown in the Pictorial diagrams and as called out in the wiring instructions. It would be easy, for example, to install a 2200 Ω (red-red-red) resistor in a step that calls for a 220 Ω (red-red-brown) resistor.

4. Recheck the wiring. Trace each lead in colored pencil on the Pictorial as you check it. It is frequently helpful to have a friend check your work. Someone who is not familiar with the unit may notice something you have consistently overlooked.
 5. Check all component leads connected to the circuit boards. Make sure the leads do not extend too far through the circuit board and make contact with other connections or parts, such as shields or the chassis.
 6. Check all of the wires that are connected to the circuit boards to be sure the wires do not touch the chassis or other lugs. Make sure all wires are properly soldered.
 7. If the difficulty still is not cured, read the "Precautions for Bench Testing" section, and the section titled "Troubleshooting."
- Do not remove any components or circuit boards while the Oscilloscope Calibrator is turned on.
 - When you make repairs to the Calibrator, make sure you eliminate the cause as well as the effect of the trouble. If, for example, you should find a damaged resistor, be sure you find out what (wiring error, etc.) caused the resistor to become damaged. If the cause is not eliminated, the replacement resistor may also become damaged when the Calibrator is put back into operation.
 - Refer to the "X-Ray Views," "Component Charts," and the "Schematic Diagram" to locate the various components.
 - Use a high impedance voltmeter and an oscilloscope to make the specified measurements in this section.
 - If you suspect that a transistor is defective, first measure the base-to-emitter voltage (V_{be}). This voltage is normally between .6 and .8 volts. If the voltage is above this range, the transistor is open. If the voltage is 0 volts, the transistor may be shorted or a base-to-emitter short exists (possibly on the foil side of the circuit board).

Precautions for Bench Testing

WARNING: The full AC line voltage and high voltage DC is present at several points in the calibrator. Be careful to avoid electrical shock when working on the Calibrator.

- Be cautious when testing transistors and integrated circuits. Although they have almost unlimited life when used properly, they are much more vulnerable to damage from excessive voltage and current than other circuit components.
- Be careful so you do not short any terminals to ground when you make voltage measurements. If the probe should slip, for example, and short out a bias or voltage supply point, it may damage one or more components.

NOTE: In an extreme case where you are unable to resolve a difficulty, refer to the "Customer Service" information inside the rear cover of the Manual. Your Warranty is located inside the front cover.

Troubleshooting

- The following symbols and procedures are used in the troubleshooting charts:



Follow the "YES" arrow when you obtain the proper measurement or condition.



Follow the "NO" arrow when you do not obtain the proper measurement or condition.

≈ This symbol, "APPROXIMATELY EQUAL TO," before a voltage measurement indicates that this voltage may vary as much as $\pm 20\%$.

- All voltages given in the troubleshooting charts were taken with a normal line voltage of 117 VAC.
- Components are listed in the order in which failure or a problem is most likely to occur.

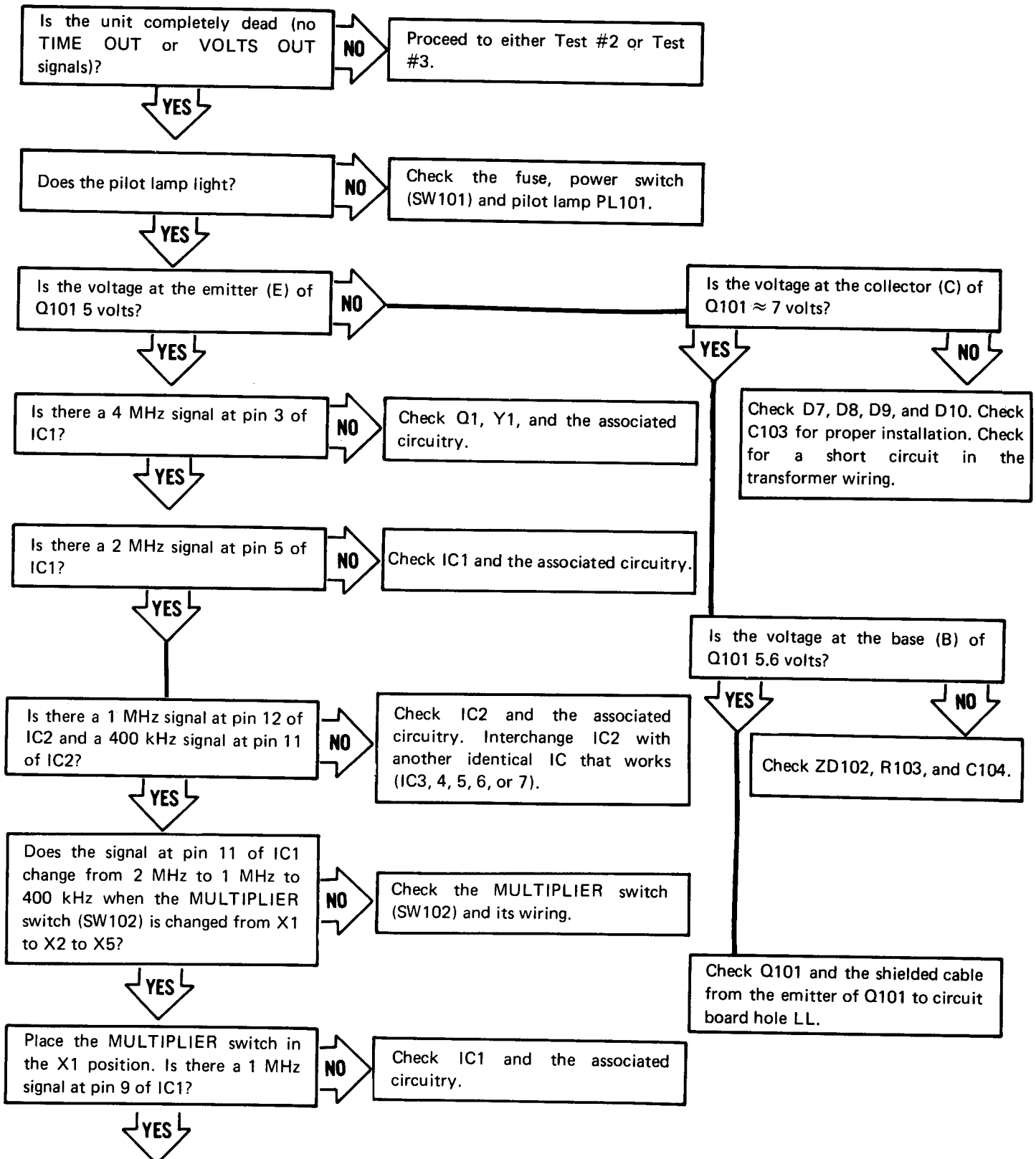
TEST #1 START HERE

Continued on Page 42

Test # 1 Cont'd.

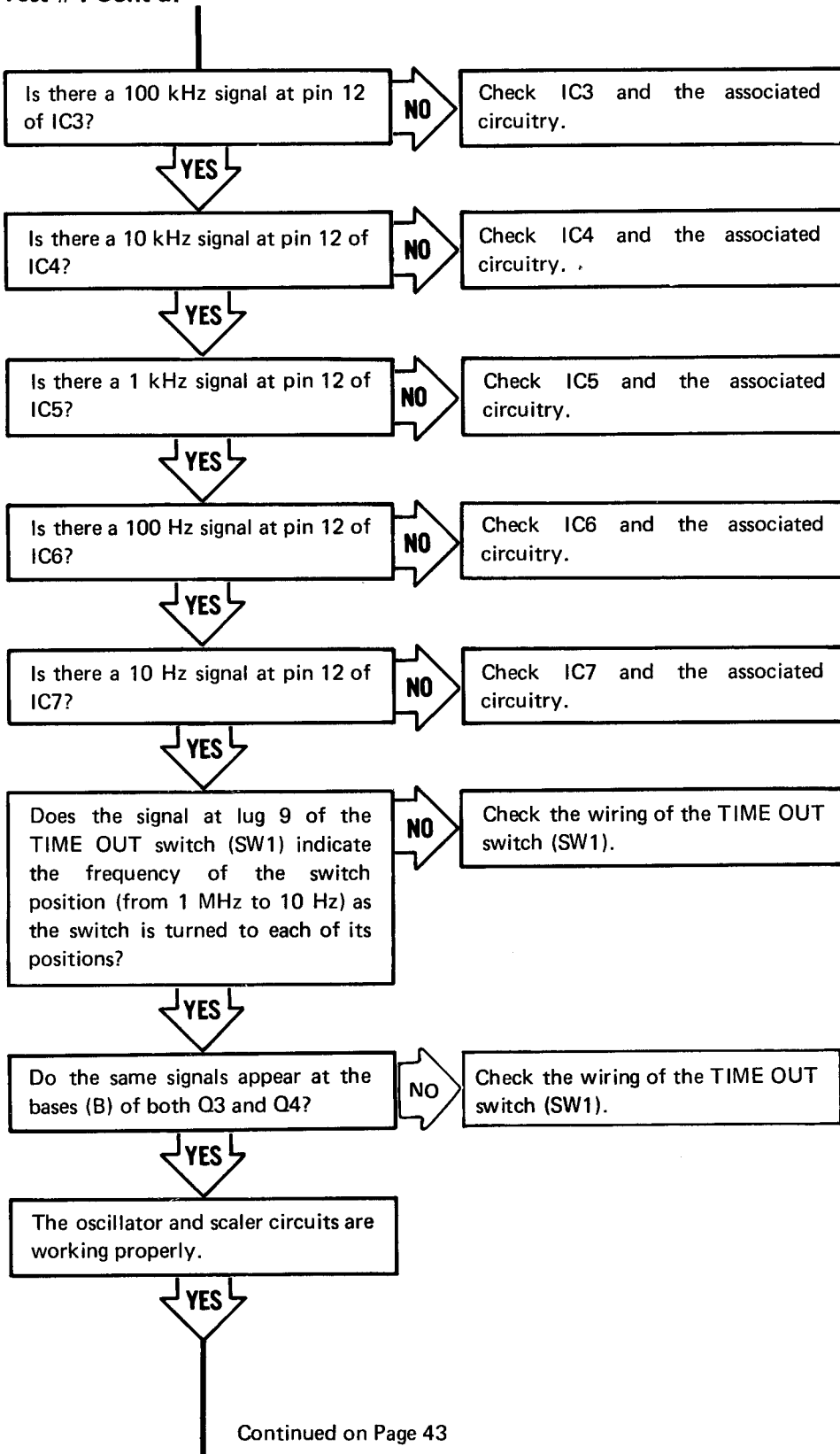

Test #1 Cont'd.

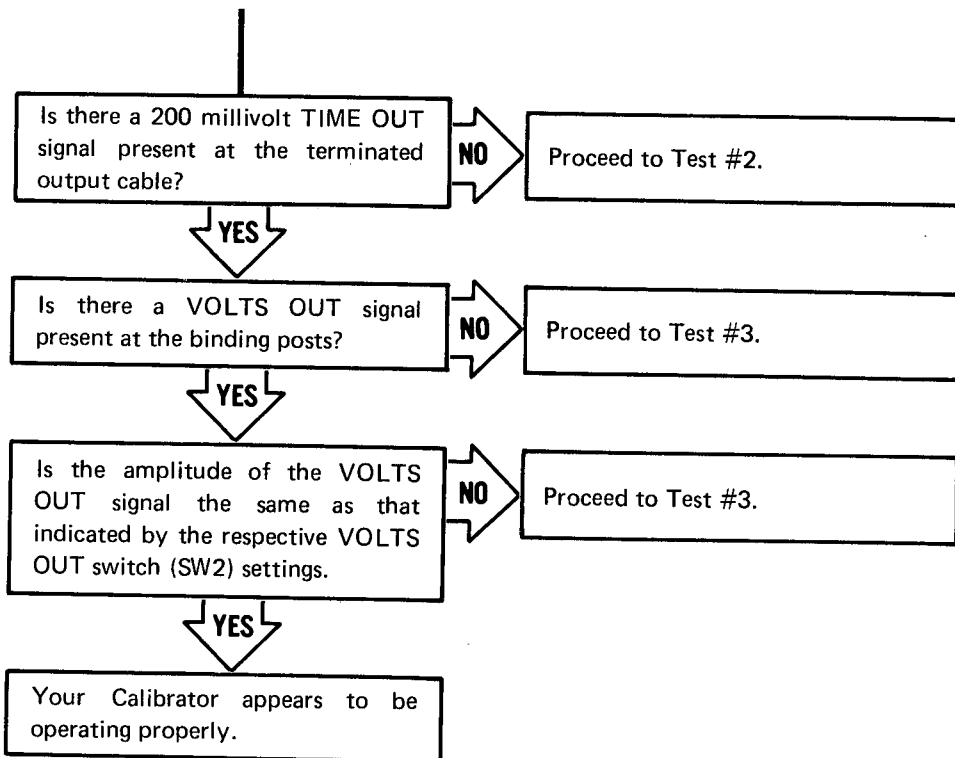

TEST #2

Perform this test if you have a VOLTS OUT signal, but no TIME OUT signal.

START

Set the TIME OUT switch (SW1) to the 1 mS position.

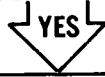

Is there a 1000 Hz (1 mS) signal at the base (B) of Q4?



Perform the steps in TEST #1.



Is there a 1000 Hz signal at the collector (C) of Q5?



Check Q4, Q5, and the associated circuitry.



Is there a 1000 Hz signal at the connector end of the terminated output cable?



Check for a short circuit at both ends of the output cable. Check R25, R26, R29, and the associated circuitry.



The TIME OUT function of your Calibrator appears to be operating properly.

TEST #3

Perform this test if you have a TIME OUT signal, but no VOLTS OUT signal.

START

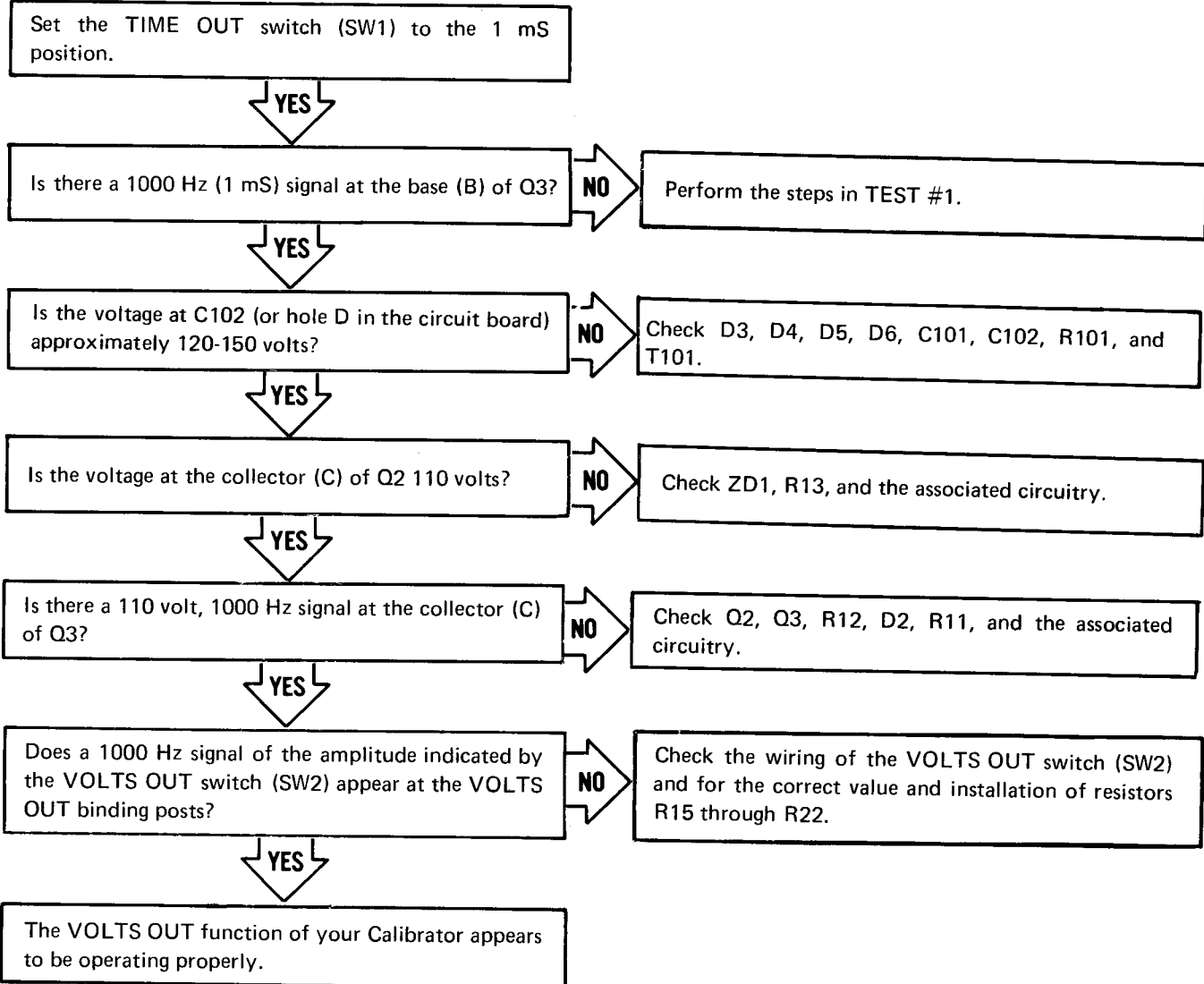





SPECIFICATIONS

TIME OUTPUT SIGNAL

Range	0.5 s to 1 μ s square wave in a 1-2-5 sequence.
Accuracy	0.01%.
Amplitude	200 mV peak (approx.)
Rise Time	\leq 4 ns.
Overshoot	\leq 3%.
Output	50 Ω terminated cable.

VOLTAGE OUTPUT SIGNAL

Ranges	1 mV to 100 V peak square wave.
Accuracy	Within 2% into a 1 M Ω load when referenced to the 1V position.
Rise Time	\leq 2 μ s.
Frequency	DC, 2 Hz to 10 kHz in a 1-2-5 sequence.

GENERAL

Internal Voltage Reference	5 volts \pm 1%.
Power Requirements	120/240 VAC, 50/60 Hz, 12 watts.
Dimensions:	
Height	7 cm (2-3/4 in.).
Width	23.2 cm (9-1/8 in.).
Depth	10.8 cm (4-1/4 in.).

The Heath Company reserves the right to discontinue products and to change specifications at any time without incurring any obligation to incorporate new features in products previously sold.

CIRCUIT DESCRIPTION

Transistor Q1, the crystal Y1 and the associated circuitry form a 4 MHz oscillator. This oscillator, the heart of the calibrator circuit, assures an accurate and stable time reference signal.

Integrated circuit IC1 contains two separate flip-flop circuits. Each flip-flop is wired to form a divide-by-two circuit. The frequency of the output signal of this type of circuit is exactly one-half the frequency of the input signal. Also, a useful characteristic of a flip-flop circuit is its symmetrical square wave output.

The 4 MHz signal is first divided by two by IC1A and coupled to the Multiplier switch and to another divider circuit IC2. This divider is a decade divider wired to produce two separate outputs, a 1 MHz output ($\div 2$) and a 400 kHz output ($\div 5$). Both of these signals are also connected to the Multiplier switch. The output signal of the Multiplier switch, either 2 MHz, 1 MHz, or 400 kHz, provides the 1-2-5 sequence of the output signal. IC1B again divides the signal by 2 ($\div 2$) to obtain a symmetrical output signal.

Integrated circuits IC3, IC4, IC5, IC6, and IC7 are decade dividers. The period of the output signal of a decade divider is ten times the period of its input signal. Thus, the output signal of IC1B is successively divided by ten by IC3, IC4, IC5, IC6, and IC7. This produces .1 s to 1 μ s output signals in a 1-2-5 sequence.

The Time Out switch (SW1) selects one of the scaled signals and couples it to the base of transistor Q3 in the Volts Out circuitry, and to the base of transistor Q4 in the Time Out circuitry.

Resistor R24 limits the current through transistors Q4 and Q5 to prevent either of them from saturating. Since they can only operate in their active region, they can switch (turn on and off) very quickly. Transistor Q4 is turned on and off by the square wave signal from the Time Out switch. When the signal is low (logic 0) transistor Q4 turns on and when the signal goes high (logic 1) transistor Q4 turns off. Since the emitters of Q4 and Q5 are coupled together, Q4 can control Q5. Transistor Q5 is normally biased on by resistors R27 and R28. When Q4 turns on, it starves current from Q5, causing Q5 to turn off very quickly. Then as Q4 turns off, current is again available to Q5 and it turns on very quickly.

This turn on and off of Q5 occurs very rapidly producing a fast rise time (≤ 4 ns) output signal.

Resistors R26, R29, and termination resistor R104 provide the proper impedance to drive and terminate the output cable with a minimum of ringing and reflections.

Transistors Q2 and Q3 form a totem-pole switch driven by the signal from the Time Out switch. The collector voltage of Q3 is either at near zero volts or at 110 volts. Calibration control R14 is adjusted so the voltage across R15 through R22 is 100 volts. The Volts Out switch (SW2) selects one of six output voltages (1 mV to 100 V).

Transistor Q101, zener diode ZD102, and the associated power supply circuitry forms a series regulator circuit to operate the logic circuits. The voltage at test point 2 (TP2), which is 5 volts $\pm 1\%$, is used only during calibration as a comparison or reference voltage. Calibration control R14 is adjusted during calibration so the voltage at TP1 is also 5 volts $\pm 1\%$.

CIRCUIT BOARD X-RAY VIEW

NOTE: To find the PART NUMBER of a component for the purpose of ordering a replacement part:

- A. Find the circuit component number (R5, C3, etc.) on the "X-Ray View."
- B. Locate this same number in the "Circuit Component Number" column of the "Parts List" in the front of this Manual.
- C. Adjacent to the circuit component number, you will find the PART NUMBER and DESCRIPTION which must be supplied when you order a replacement part.

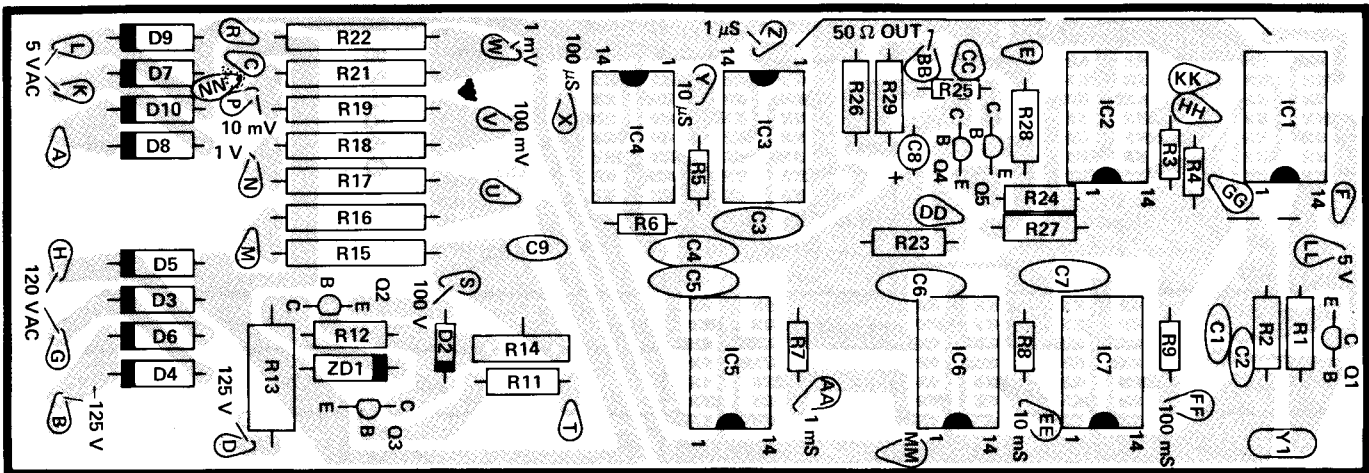

(Viewed from foil side)

CIRCUIT BOARD VOLTAGE CHART

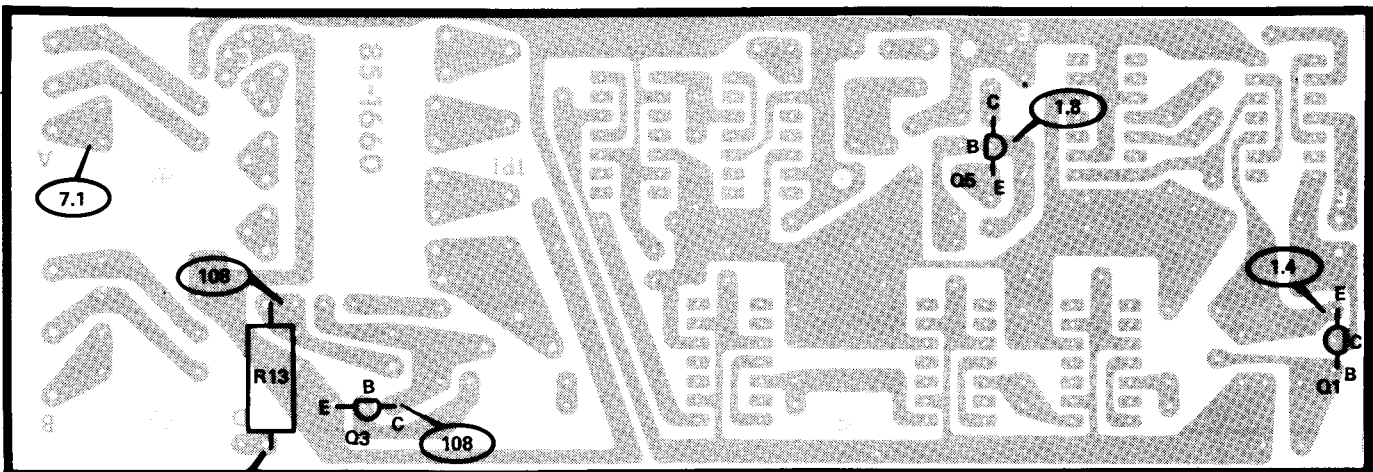

(Viewed from foil side)

IDENTIFICATION CHARTS

DIODES

COMPONENT	HEATH PART NUMBER	MAY BE REPLACED WITH	IDENTIFICATION
ZD101	56-85	SZ5.0 ZENER DIODE DIODE $\pm 1\%$	<p>NOTE: HEATH PART NUMBERS ARE STAMPED ON MOST DIODES.</p>
ZD102	56-63	MZ500-10 ZENER DIODE	
ZD1	56-48	BZT110A ZENER DIODE	
D2	56-56	1N4149 DIODE	
D3-D10	57-27	1N2071 DIODE	

TRANSISTORS

TRANSISTORS	HEATH PART NUMBER	MAY BE REPLACED WITH	BASING DIAGRAM
Q1	417-118	2N3393	
Q2, Q3	417-811	MPS-L01	
Q4, Q5	417-292	2N5771	
Q101	417-175	2N5294	



INTEGRATED CIRCUITS

INTEGRATED CIRCUITS	HEATH PART NUMBER	MAY BE REPLACED BY	BASING DIAGRAM TOP VIEW
IC1	443-6	SN7474N	<p>The diagram shows a top view of the SN7474N integrated circuit. It features two inverters. The left inverter has inputs labeled CLEAR (pin 1), D (pin 2), and CLOCK (pin 3), and outputs labeled Q (pin 4) and \bar{Q} (pin 5). The right inverter has inputs labeled PRESET (pin 6), D (pin 7), and CLOCK (pin 8), and outputs labeled \bar{Q} (pin 9) and Q (pin 10). Power pins include VCC (pin 14), 2D (pin 12), 2CLOCK (pin 11), 2PRESET (pin 10), 2Q (pin 9), and $2\bar{Q}$ (pin 8). Pin 1 is labeled CLEAR, pin 2 is D, pin 3 is CLOCK, pin 4 is Q, pin 5 is \bar{Q}, pin 6 is PRESET, pin 7 is D, pin 8 is CLOCK, pin 9 is \bar{Q}, pin 10 is Q, and pin 14 is VCC.</p>
IC2, IC3, IC4, IC5, IC6, IC7	443-7	SN7490N	<p>The diagram shows a top view of the SN7490N integrated circuit. It contains four J-K flip-flops (J A, J B, J C, J D) and two SR flip-flops (S1, S2). The J-K flip-flops have inputs labeled A (pin 12), B (pin 13), C (pin 14), and D (pin 11), and outputs labeled A (pin 1), B (pin 2), C (pin 3), and D (pin 4). The SR flip-flops have inputs labeled S1 (pin 5) and S2 (pin 6), and outputs labeled R (pin 7) and D (pin 8). Power pins include VCC (pin 10) and GND (pin 11). Pin 1 is labeled BD INPUT, pin 2 is R₀(1), pin 3 is R₀(2), pin 4 is NC, pin 5 is S1, pin 6 is S2, pin 7 is R, pin 8 is D, pin 9 is B, pin 10 is VCC, pin 11 is GND, pin 12 is A, pin 13 is NC, pin 14 is A.</p>



KEEP THIS PARTS LIST WITH YOUR MANUAL AND USE THE PRICES SHOWN BELOW (DISREGARD ANY PRICES SHOWN IN YOUR MANUAL) WHEN ORDERING PARTS. THESE PRICES ARE SUBJECT TO CHANGE WITHOUT NOTICE.

PART NUMBER	PRICE	* PART NUMBER	PRICE	* PART NUMBER	PRICE	* PART NUMBER	PRICE
1-	9-1	.30	* 343-	15	.10	* *	*
2-	1	.60	* 344-	5	.05	* *	*
3-	5	.60	* 344-	5	.05	* *	*
4-	5	.60	* 344-	72	.05	* *	*
5-	10	.60	* 344-	74	.05	* *	*
6-	173	.45	* 346-	4	.05	* *	*
6-	100-12	.25	* 346-	60	.10	* *	*
6-	102	.25	* 354-	6	.15	* *	*
6-	102-12	.25	* 390-	1255	.15	* *	*
6-	104	.25	* 391-	34	.20	* *	*
6-	121	.25	* 404-	536	5.20	* *	*
6-	159	.25	* 412-	15	.30	* *	*
6-	181	.25	* 413-	10	.15	* *	*
6-	221	.25	* 417-	118	.50	* *	*
6-	273	.25	* 417-	175	1.60	* *	*
6-	411	.25	* 417-	297	1.3	* *	*
6-	510-12	.25	* 417-	811	.25	* *	*
6-	510-12	.25	* 421-	40	.65	* *	*
6-	681	.25	* 427-	3	.40	* *	*
6-	821	.25	* 431-	2	.15	* *	*
10-	390	.75	* 431-	422	.15	* *	*
21-	3	.25	* 431-	822	.15	* *	*
21-	16	.25	* 431-	86	.15	* *	*
21-	32	1.25	* 432-	134	.03	* *	*
22-	20	.75	* 432-	919	3.50	* *	*
22-	119	.90	* 432-	298	.25	* *	*
51-	22	.75	* 443-	9	.95	* *	*
51-	805	5.50	* 443-	9	1.65	* *	*
56-	48	1.45	* 455-	619	1.15	* *	*
56-	56	.25	* 466-	264	1.05	* *	*
56-	63	.25	* 490-		.25	* *	*
56-	85	1.55	* *			* *	*
57-	27	.60	* *			* *	*
60-	71	.70	* *			* *	*
69-	73	1.20	* *			* *	*
69-	1237	3.60	* *			* *	*
73-	17	.45	* *			* *	*
75-	52	.05	* *			* *	*
75-	71	.15	* *			* *	*
89-	1660-2	2.15	* *			* *	*
89-	23	2.50	* *			* *	*
90-	320-2	2.55	* *			* *	*
100-	16-2	.25	* *			* *	*
100-	18-18	.25	* *			* *	*
209-	1238-1	3.20	* *			* *	*
250-	89	.25	* *			* *	*
250-	170	.05	* *			* *	*
252-	3	.05	* *			* *	*
252-	7	.05	* *			* *	*
252-	9	.05	* *			* *	*
252-	15	.05	* *			* *	*
252-	10	.05	* *			* *	*
254-	1	.05	* *			* *	*
259-	1	.05	* *			* *	*
361-	1	.05	* *			* *	*
361-	6	.05	* *			* *	*
343-	2	.20	* *			* *	*

ADDITIONAL 3' ROLLS OF SOLDER, #331-6, CAN BE ORDERED FOR 25 CENTS EACH.

The prices shown on this "Heath Parts Price List" apply only on purchases from the Heath Company where shipment is to a U.S.A. destination. Add 10% (minimum 25 cents) to the price when ordering (Michigan residents add 4% sales tax) to cover insurance, postage, and handling. Outside the U.S.A., parts and service are available from your local Heathkit source and will reflect additional transportation, taxes, duties, and rates of exchange.