

# HEATHKIT<sup>®</sup> MANUAL

*for the*

**LASER RECEIVER**  
Model ETA-4200

595-3367-01



HEATH COMPANY • BENTON HARBOR, MICHIGAN

## Table of Contents

Introduction . . . . .	2	In Case of Difficulty . . . . .	20
		Troubleshooting Chart . . . . .	21
Assembly Notes . . . . .	3	Specifications . . . . .	22
Parts List . . . . .	6	Circuit Description . . . . .	23
Step-by-Step Assembly . . . . .	8	Circuit Board X-Ray View . . . . .	23
Circuit Board Assembly . . . . .	8	Semiconductor Identification Chart . . . . .	24
Chassis Assembly . . . . .	13	Schematic Diagram . . . . .	25
Initial Tests . . . . .	17	Customer Service . . . . .	inside the back cover
Final Assembly . . . . .	18	Warranty . . . . .	inside the front cover
Adjustments . . . . .	19		

## INTRODUCTION

Your Model ETA-4200 Laser Receiver is a complementary unit to your ET-4200 Laser Trainer. Its purpose is to capture the laser beam from the Trainer and to decipher any intelligence present on it.

The built-in meter will provide an indication of the laser beam's intensity to help you determine the beam profile and power density.

The Receiver's audio amplifier will reproduce any audio information that was encoded on the beam by the modulation circuits in the Laser Trainer. The Receiver will also detect other types of beam modulation, such as that from an interferometer.

You will need two NEDA Type 1604A 9-volt alkaline batteries for this kit. We suggest that you purchase these batteries right away so that you have them on hand when you complete the assembly of your kit.

## ASSEMBLY NOTES

### TOOLS

You will need these tools to assemble your kit.

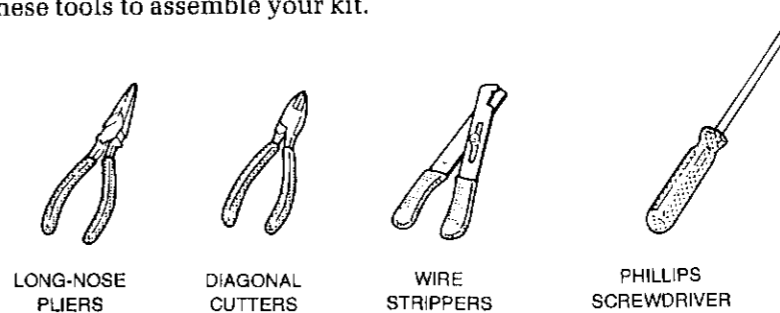

### OTHER HELPFUL TOOLS

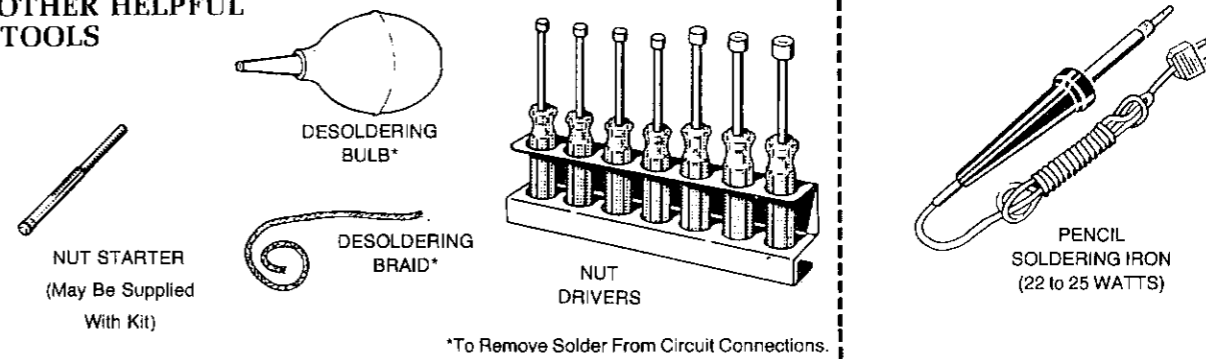

### ASSEMBLY

1. Follow the instructions carefully. Read the entire step before you perform each operation.
2. The illustrations in the Manual are called Pictorials and Details. Pictorials show the overall operation for a group of assembly steps; Details generally illustrate a single step. When you are directed to refer to a certain Pictorial "for the following steps," continue using that Pictorial until you are referred to another Pictorial for another group of steps.
3. Most kits use a separate "Illustration Booklet" that contains illustrations (Pictorials, Details, etc.) that are too large for the Assembly Manual. Keep the "Illustration Booklet" with the Assembly Manual. The illustrations in it are arranged in Pictorial number sequence.
4. Position all parts as shown in the Pictorials.
5. Solder instructions are generally given only at the end of a series of similar steps. You may solder more often if you desire.

6. Each circuit part in an electronic kit has its own component number (R2, C4, etc.). Use these numbers when you want to identify the same part in the various sections of the Manual. These numbers, which are especially useful if a part has to be replaced, appear:

- In the Parts List,
- At the beginning of each step where a component is installed,
- In some illustrations,
- In Troubleshooting Charts,
- In the Schematic,
- In the sections at the rear of the Manual.

7. When you are instructed to cut something to a particular length, use the scales (rulers) provided at the bottom of the Manual pages.

**SAFETY WARNING: Avoid eye injury when you cut off excessive lead lengths. Hold the leads so they cannot fly toward your eyes.**

**SOLDERING**

Soldering is one of the most important operations you will perform while assembling your kit. A good solder connection will form an electrical connection between two parts, such as a component lead and a circuit board foil. A bad solder connection could prevent an otherwise well-assembled kit from operating properly.

It is easy to make a good solder connection if you follow a few simple rules:

1. Use the right type of soldering iron. A 22 to 25-watt pencil soldering iron with a 1/8" or 3/16" chisel or pyramid tip works best.
2. Keep the soldering iron tip clean. Wipe it often on a wet sponge or cloth; then apply solder to the tip to give the entire tip a wet look. This process is called tinning, and it will protect the tip and enable you to make good connections. When solder tends to "ball" or does not stick to the tip, the tip needs to be cleaned and retinned.

NOTE: Always use rosin core, radio-type solder (60:40 tin-lead content) for all of the soldering in this kit. This is the type we have supplied with the parts. The Warranty will be void and we will not service any kit in which acid core solder or paste has been used.

**PARTS**

Resistors are identified in Parts Lists and steps by their resistance value in Ω (ohms), kΩ (kilohms), or MΩ (megohms). They are usually identified by a color code and four or five color bands, where each color represents a number. These colors (except for the last band, which indicates a resistor's "tolerance") will be given in the steps in their proper order. Therefore, the following color code is given for information only. NOTE: Occasionally, a "precision" or "power" resistor may have the value stamped on it.

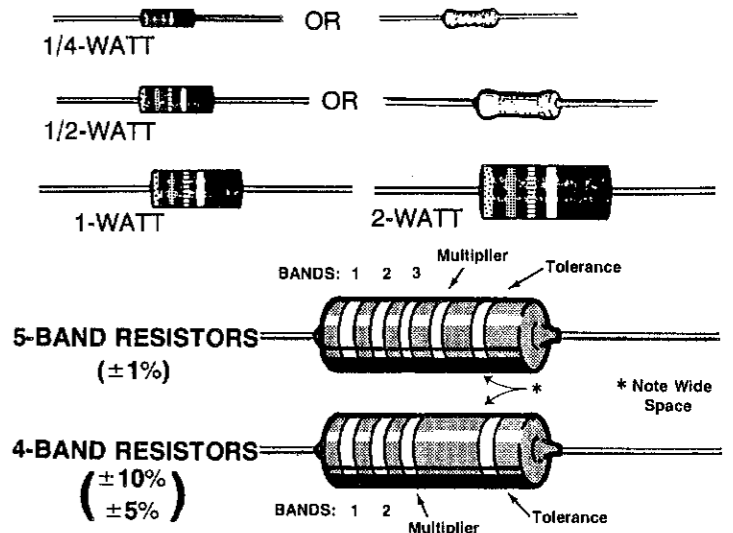

Band 1 1st Digit		Band 2 2nd Digit		Band 3 (if used) 3rd Digit		Multiplier		Resistance Tolerance	
Color	Digit	Color	Digit	Color	Digit	Color	Multiplier	Color	Tolerance
Black	0	Black	0	Black	0	Black	1	Silver	± 10%
Brown	1	Brown	1	Brown	1	Brown	10	Gold	± 5%
Red	2	Red	2	Red	2	Red	100	Red	± 2%
Orange	3	Orange	3	Orange	3	Orange	1,000	Brown	± 1%
Yellow	4	Yellow	4	Yellow	4	Yellow	10,000	Green	± .5%
Green	5	Green	5	Green	5	Green	100,000	Blue	± .25%
Blue	6	Blue	6	Blue	6	Blue	1,000,000	Violet	± .1%
Violet	7	Violet	7	Violet	7	Silver	0.01	Gray	± .05%
Gray	8	Gray	8	Gray	8	Gold	0.1		
White	9	White	9	White	9				

Capacitors will be called out by their capacitance value in μF (microfarads) or pF (picofarads) and type: ceramic, Mylar\*, electrolytic, etc. Some capacitors may have their value printed in the following manner:

EXAMPLES:  
 151K = 15 × 10 = 150 pF  
 759 = 75 × 0.1 = 7.5 pF

NOTE: The letter "R" may be used at times to signify a decimal point; as in: 2R2 = 2.2 (pF or μF).

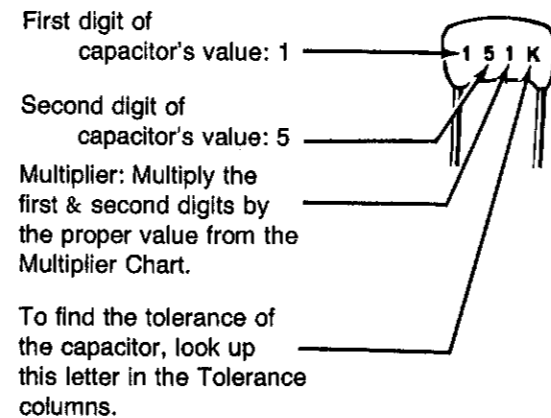

MULTIPLIER		TOLERANCE OF CAPACITOR		
FOR THE NUMBER:	MULTIPLY BY:	10 pF OR LESS	LETTER	OVER 10 pF
0	1	±0.1 pF	B	
1	10	±0.25 pF	C	
2	100	±0.5 pF	D	
3	1000	±1.0 pF	F	±1%
4	10,000	±2.0 pF	G	±2%
5	100,000		H	±3%
			J	±5%
8	0.01		K	±10%
9	0.1		M	±20%

\*DuPont Registered Trademark.

**PARTS LIST**

Check each part against the following list and the accompanying "Parts Pictorial." The key numbers correspond to the numbers on the "Parts Pictorial." Return any part that is packed in an individual envelope, with the part number on it, back into its envelope until that part is called for in a step. Do not throw away any packing material until you have accounted for all the parts.

To order a replacement part, always include the PART NUMBER. Use the Parts Order Form furnished with this kit. If a Parts Order Form is not available, refer to "Replacement Parts" inside the rear cover of this Manual. For prices, refer to the separate "Heath Parts Price List."

KEY No.	HEATH Part No.	QTY.	DESCRIPTION	CIRCUIT Comp. No.
---------	----------------	------	-------------	-------------------

**RESISTORS**

NOTE: The following resistors are 1/4-watt, 5% tolerance (gold fourth band) unless otherwise stated.

A1	6-100-12	1	10 Ω (brn-blk-blk)	R9
A1	6-472-12	2	4700 Ω (yel-viol-red)	R4, R5
A1	6-273-12	1	27 kΩ (red-viol-org)	R7
A1	6-473-12	1	47 kΩ (yel-viol-org)	R3
A1	6-474-12	1	470 kΩ (yel-viol-yel)	R2

**CAPACITORS**

B1	21-176	1	.01 μF ceramic	C5
B2	25-880	2	10 μF electrolytic	C3, C4
B3	25-887	3	220 μF electrolytic	C1, C2, C6

**METAL PARTS**

C1	90-1343-1	1	Cabinet top
C2	90-1344-1	1	Chassis
C3	204-2375	1	Meter bracket
C4	208-48	2	Battery holder

KEY No.	HEATH Part No.	QTY.	DESCRIPTION	CIRCUIT Comp. No.
---------	----------------	------	-------------	-------------------

**HARDWARE**

D1	250-321	4	4-40 × 1/8" screw
D2	250-1423	2	6-32 × 3/8" flat head screw
D3	250-1280	10	6-32 × 3/8" screw
D4	250-1432	4	#6 × 3/8" sheet metal screw
D5	252-3	6	6-32 nut
D6	253-1	4	#6 fiber washer
D7	254-1	8	#6 lockwasher

**CABLE-WIRE**

134-1322	1	Cable assembly
344-52	6"	Red wire
344-54	6"	Yellow wire
344-55	12"	Green wire
344-56	6"	Blue wire
344-59	9"	White wire

**GENERAL**

E1	9-108	1	Sensor	
E2	10-1138	2	10 kΩ control	R6, R8
E2	10-1213	1	1 MΩ control	R1
E3	60-2	1	Slide switch	SW1
E4	401-210	1	Speaker	SP1
E5	407-705	1	Meter	M1

KEY No.	HEATH Part No.	QTY.	DESCRIPTION	CIRCUIT Comp. No.
---------	----------------	------	-------------	-------------------

**General (cont'd)**

NOTE: Integrated circuits may be marked for identification in any of the following four ways:

1. Part number.
2. Type number (this refers only to the numbers printed in **bold** type; the letters may be different or missing).
3. Part number and type number.
4. Part number with a type number other than the one listed.

E6	442-21	1	<b>MC1458</b> IC	U1
E6	442-612	1	<b>LM386N</b> IC	U2

KEY No.	HEATH Part No.	QTY.	DESCRIPTION	CIRCUIT Comp. No.
---------	----------------	------	-------------	-------------------

**MISCELLANEOUS**

	73-92	1	Double-sided foam tape	
	85-3013-1	1	Printed circuit board	
F1	255-71	2	Threaded spacer	
F2	261-49	4	Foot	
F3	432-798	2	Battery clips	
F4	434-230	2	8-pin IC socket	
F5		1	Blue and white label	
	597-260	1	Parts Order Form	
		1	Assembly Manual (See title page for part number.)	
			Solder	

NOTE: You will need two NEDA Type 1604A 9-volt alkaline batteries for this kit. We suggest that you purchase these batteries right away so you have them on hand when you complete the assembly of your kit.

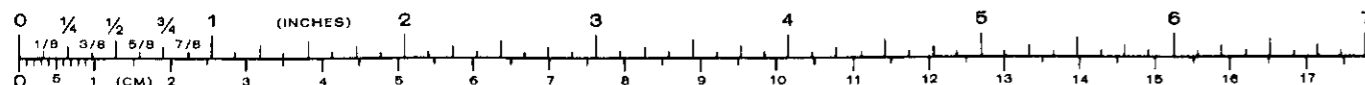

## STEP-BY-STEP ASSEMBLY

## CIRCUIT BOARD ASSEMBLY

Refer to Pictorial 1-1 (Illustration Booklet, Page 2) as you read the following notes and perform the following steps.

NOTE: In the following steps, you will be given detailed instructions on how to install and solder the first part on the circuit board. Read and perform each step carefully. Then use the same procedure as you install the remaining parts on the board.

Note that the circuit board has foil patterns on one side and outlines of components (parts) on the other side. The side with the foils will be called the "foil side," and the other side will be called the "component" side.

( ) Position the circuit board on your work area in front of you with the component side up as shown in Pictorial 1-1. NOTE: Always install parts on the component side of the circuit board and solder the leads or wires to the circuit board foils, unless you are specifically directed to do otherwise.

( ) Locate the first part, a 470 k $\Omega$  (yel-viol-yel) resistor. Bend the resistor leads as shown to fit the hole spacing at R2 on the circuit board.

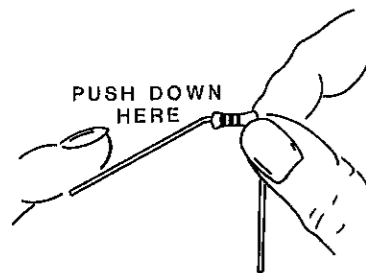

( ) R2: Start the leads into the holes at the resistor location near the top left corner of the circuit board. The end with the color bands may be positioned either way. NOTE: Resistors are identified by the following outline:

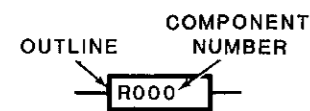

( ) Press the resistor down against the top of the circuit board. Then bend the leads outward slightly to hold it in place.



( ) Solder the resistor leads to the circuit board as follows:

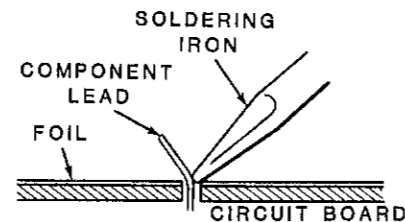

1. Push the soldering iron tip against both the lead and the circuit board foil. Heat **both** for two or three seconds.

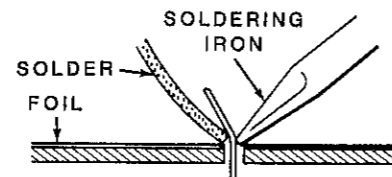

2. Then apply solder to the other side of the connection. **IMPORTANT:** Let the heated lead and the circuit board foil melt the solder.

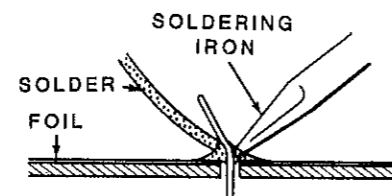

3. As the solder begins to melt, allow it to flow around the connection. Then remove the solder and the iron and let the connection cool.

( ) Cut off the excess lead lengths close to the connection. **WARNING:** Clip the leads so the ends will not fly toward your eyes.

( ) Check each connection. Compare it to the illustrations in Figure 1 (Illustration Booklet, Page 2). After you have checked the solder connections, proceed with the assembly on this and on the following pages. Use the same soldering technique for each connection.

( ) R5: 4700  $\Omega$  (yel-viol-red).

( ) R3: 47 k $\Omega$  (yel-viol-org).

( ) R4: 4700  $\Omega$  (yel-viol-red).

( ) R7: 27 k $\Omega$  (red-viol-org).

( ) R9: 10  $\Omega$  (brn-blk-blk).

( ) Cut two 1" pieces of white wire. Remove all the insulation from each wire. Use these bare wires for jumpers in the next two steps.

NOTE: In the next two steps, when a bare wire jumper is called for, form each bare wire to fit the hole spacing on the circuit board. After you install a wire, bend its ends outward as you did with other components.

( ) W1: 1" bare wire jumper.

( ) W2: 1" bare wire jumper.

( ) Solder the leads and wires to the foil and cut off the excess lengths.

Refer to Pictorial 1-2 (Illustration Booklet, Page 2) for the following steps.

As you install IC sockets, be very careful that you do not bridge solder between socket pins. (Solder between two pins on the same foil is all right.) If a solder bridge should occur, hold the circuit board bottom side down. Then hold your soldering iron tip between the two points where solder is bridged. The solder will flow down the iron. You can also use desoldering braid (not supplied).

To install IC sockets, as in the following steps, be sure the socket pins are straight and insert the socket pins into their designated holes. The notch on the socket should be positioned to correspond with the index mark on the circuit board as shown. The index mark must still be visible after you have installed the socket. Solder the pins to the foil as you install each socket. The sockets supplied in your kit may have fewer or a greater number of pins than shown here.

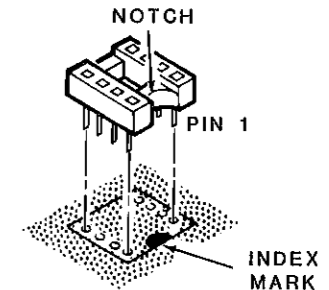

( ) 8-pin IC socket at U1. Solder its pins to the foil.

( ) 8-pin IC socket at U2. Solder its pins to the foil.

**CAUTION:** Integrated circuits (ICs) are complex electronic devices that perform many complicated functions in the circuit. However, these devices can be damaged during installation. Read all of the following information before you install any ICs.

The pins on the ICs are bent out at an angle so they do not line up with the holes in the IC socket. **DO NOT** try to install an IC without first bending the pins. To do so may damage the IC pins or the socket, causing intermittent contact.

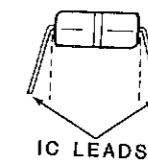

Before you install an IC, lay it down on its side as shown and very carefully roll it toward the pins to bend the lower pins into line. Then turn the IC over and bend the pins to the other side in the same manner.

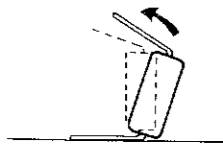

Compare the IC to the drawing shown below. Then determine which end of the IC is the pin 1 end.

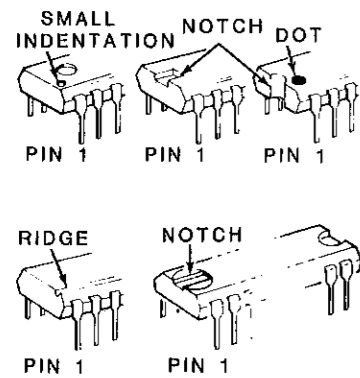

Make sure that the pin 1 end of the IC is positioned over the index mark on the circuit board. Also make sure that all of the pins are started into the socket. Then press the IC firmly into the socket. NOTE: An IC pin can become bent under the IC and it will appear as though it is correctly installed in the socket.

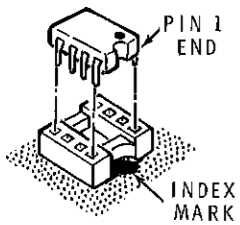

Use an IC lifter or the blade of a small screwdriver to lift and remove ICs from their sockets, if necessary, without bending the IC pins.

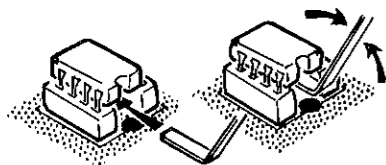

- ( ) U1: MC1458 IC at U1.
- ( ) U2: LM386N-4 IC at U2.

NOTE: In the following step, when you install the ceramic capacitor, do not push the insulated portion of the leads into the holes. This could make it difficult to solder the leads to the foil.

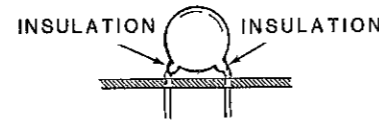

- ( ) C5: .01  $\mu$ F ceramic capacitor.

NOTE: In the following steps, when you install electrolytic capacitors, always match the negative (-) mark on the capacitor with the negative (-) mark on the circuit board, or match the positive (+) mark on the capacitor with the positive (+) mark on the board.

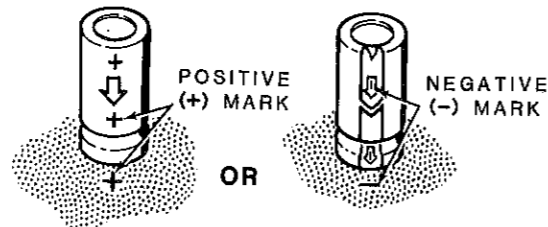

- ( ) C1: 220  $\mu$ F electrolytic.
- ( ) C2: 220  $\mu$ F electrolytic.
- ( ) C3: 10  $\mu$ F electrolytic.
- ( ) C4: 10  $\mu$ F electrolytic.
- ( ) C6: 220  $\mu$ F electrolytic.
- ( ) Solder the leads to the foil and cut off the excess lead lengths.

Refer to Pictorial 1-3 (Illustration Booklet, Page 2) for the following steps.

NOTE: In the following steps, when you install controls on the circuit board, position them as shown below. Push each control all the way down onto the surface of the circuit board; then solder its leads to the foil and cut off the excess lead lengths.

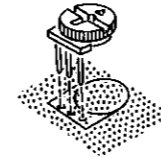

- ( ) R1: 1 M $\Omega$  control (#10-1213). Bend the leads of this control so it will be flat on the board as shown above.
- ( ) R6: 10 k $\Omega$  control (#10-1138).
- ( ) R8: 10 k $\Omega$  control (#10-1138).

NOTE: To prepare wires, as in the following steps, cut the wires to the lengths indicated. Then remove 1/4" of insulation from each wire end.

- ( ) Prepare the following wires:
  - Two 5" green      5" white
  - 5" red            5" blue
  - 5" yellow

- ( ) Tightly twist together the two green wires, making sure both ends are even.
- ( ) In the same manner, twist together the 5" red and yellow wires.
- ( ) In the same manner, twist together the 5" white and blue wires.

NOTE: In the following steps, when you install a wire in a circuit board hole, solder it to the foil and cut off the excess wire end. Connect only one end of each twisted pair at this time; the free ends will be connected later.

- ( ) Red-yellow wires: Yellow wire to hole E; red wire to hole G.
- ( ) White-blue wires: White wire to hole F; blue wire to hole H.
- ( ) Green wires: One green to hole I; other green to hole J.
- ( ) Refer to Detail 1-3A and cut the wires of the two battery clips to 6". To prepare the wires, remove 1/4" of insulation from each wire end. Then tightly twist each bare wire end and add a small amount of solder to hold the fine strands together.

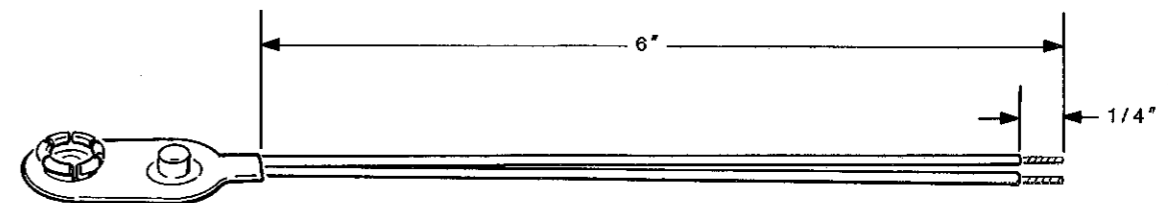

DETAIL 1-3A

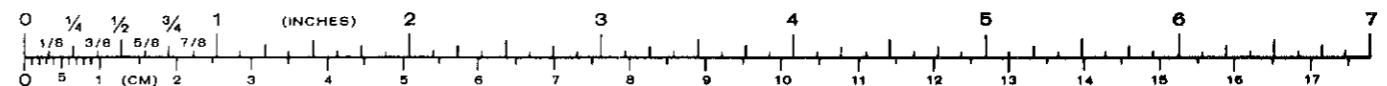

Connect the wires coming from the battery clips to the circuit board holes as follows:

- ( ) Black wire from one battery clip to hole C.
- ( ) Red wire from the **other** battery clip to hole D.
- ( ) Solder the wires to the foil and cut off the excess wire ends.
- ( ) Refer to Detail 1-3B and mount a threaded spacer on the component side of the circuit board at P with a 6-32 × 3/8" screw and a #6 lockwasher. Be sure to place the lockwasher between the spacer and the circuit board as shown.
- ( ) In the same manner, mount the remaining threaded spacer on the circuit board at R.

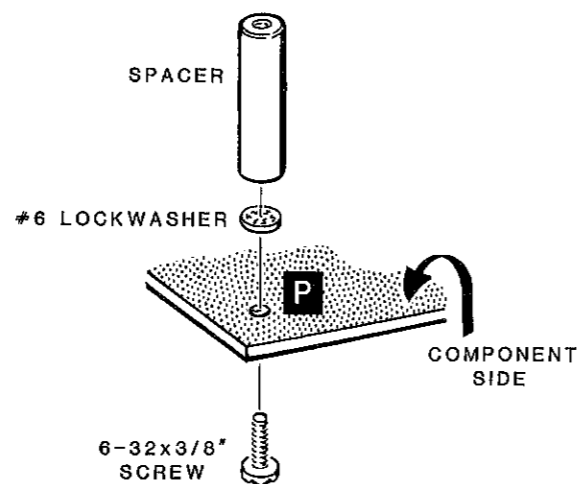

DETAIL 1-3B

### CIRCUIT BOARD CHECKOUT

Carefully inspect the circuit board for the following conditions.

- ( ) Unsoldered connections.
- ( ) Poor solder connections.
- ( ) Solder bridges between foil patterns.
- ( ) Protruding leads which could touch together.
- ( ) Electrolytic capacitors for the correct position of the positive (+) and negative (-) marks.
- ( ) ICs for the proper type and installation.

NOTE: At this time, there are two unused holes in the circuit board.

Set the circuit board aside temporarily.

### CHASSIS ASSEMBLY

Refer to Pictorial 2-1 (Illustration Booklet, Page 2) for the following steps.

- ( ) Refer to Detail 2-1A and mount a battery holder in the bottom of the chassis at E1. Use two 4-40 × 1/8" screws.
- ( ) In the same manner, mount the other battery holder at E2.

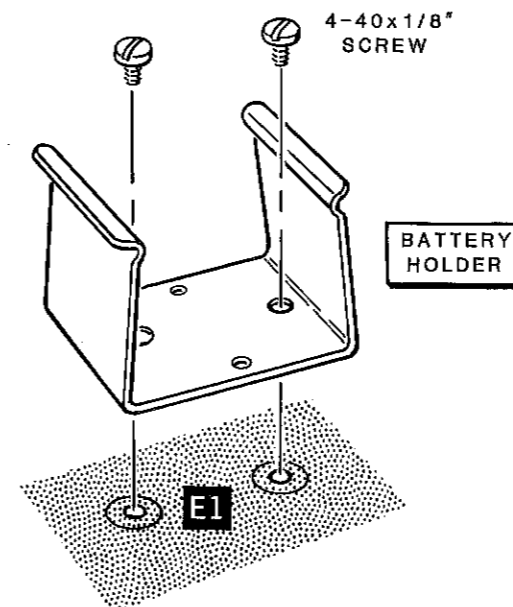

DETAIL 2-1A

NOTE: When a step calls for hardware, only the screw size is given. For instance, if "6-32 × 3/8" hardware" is called for, it means you should use a 6-32 × 3/8" screw, one or more #6 lockwashers, and a 6-32 nut at the indicated mounting hole.

- ( ) SP1: Mount the speaker onto the back panel of the chassis as shown. Secure the speaker with four sets of 6-32 × 3/8" hardware at A, B, C, and D. Be sure to position the speaker lugs up as shown in the Pictorial.
- ( ) Refer to Detail 2-1B and install the slide switch at SW1 on the chassis front panel using two 6-32 × 3/8" screws.

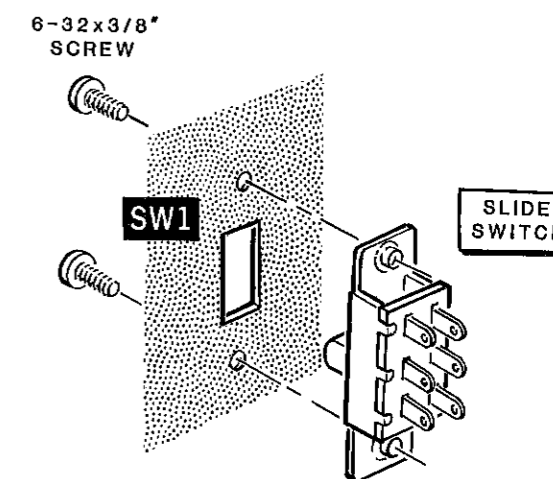

DETAIL 2-1B

Refer to Detail 2-1C for the next four steps.

- ( ) 1. Very loosely install the meter bracket in the bottom of the chassis at E and F using two sets of 6-32 × 3/8" hardware.
- ( ) 2. Cut a 1-1/2" piece of double-sided foam tape. Remove the paper backing from one side of the tape and press the tape in place on the back of the meter as shown.

NOTE: In the following step, do not remove the remaining paper backing from the foam tape.

- ( ) 3. Position the meter into the front panel cutout. Push the top of the meter bracket firmly against the foam tape on the back of the meter and tighten the bracket screws.
- ( ) 4. If there is a shorting wire between the meter lugs, remove and discard the wire.

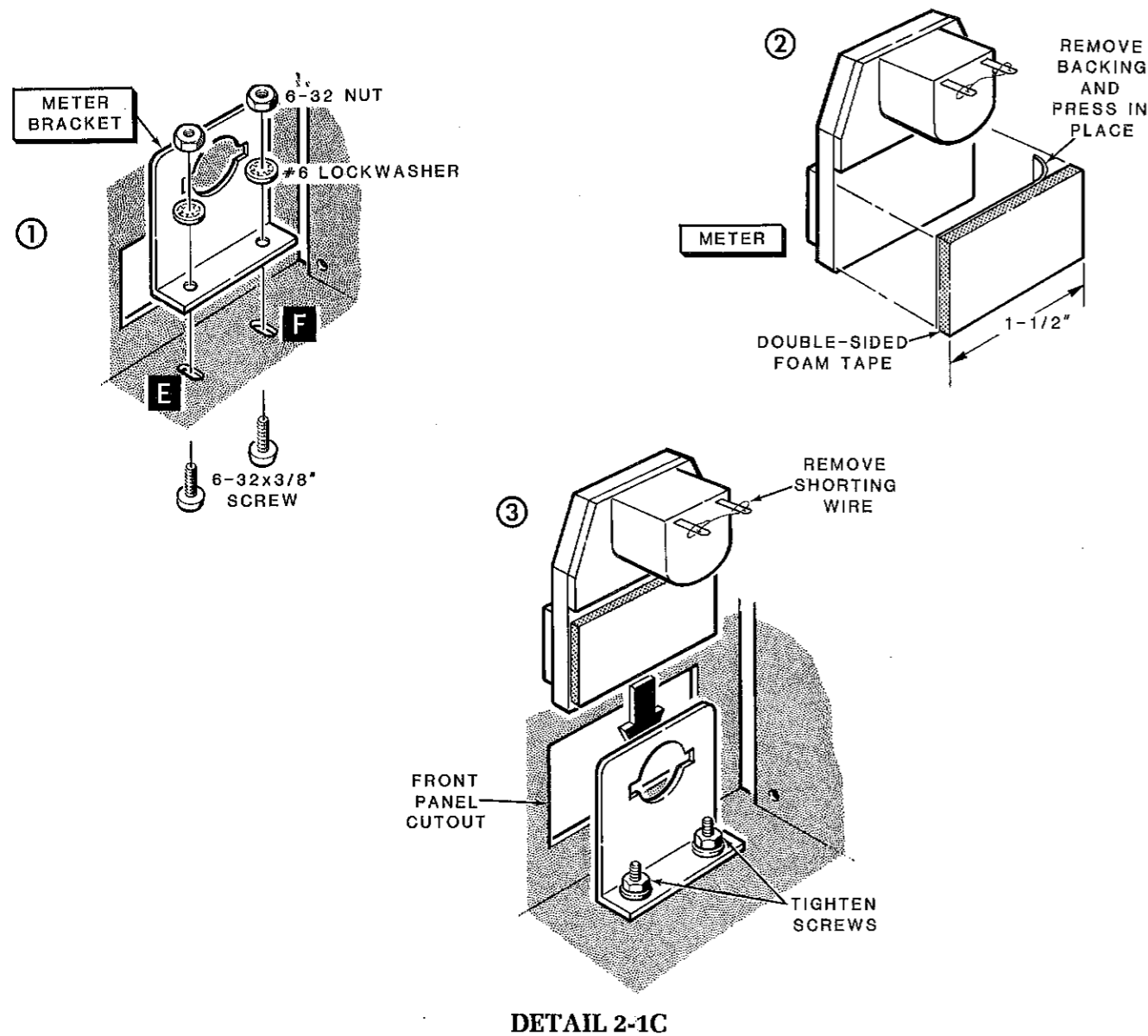

DETAIL 2-1C



Refer to Detail 2-1D for the next four steps.

- ( ) 1. Cut two 1-1/2" pieces of double-sided foam tape.
- ( ) 2. Fold one piece of foam tape in the center. Then, with scissors (or some other sharp tool), cut a diamond shape out of the center. See the inset drawing on the Detail.

- ( ) 3. Remove the backing from one side of the foam tape with the center cutout. Then carefully unwrap the sensor and position it, black side down, onto the cutout as shown. NOTE: Do not apply under pressure on the sensor; it is delicate and can easily be damaged.

- ( ) 4. Remove the backing from one side of the other piece of foam tape and press it in place on the top of the sensor; so as to sandwich the sensor between the two tapes.

- ( ) Remove the paper backing from the side of the tape with the cutout and press the tape and sensor onto the inside of the left side panel as shown in the Pictorial. Be sure the cutout in the tape is centered over the hole in the panel. NOTE: The sensor wires will be connected in another step.

NOTE: In the following steps, be sure to handle the sensor very carefully; it is fragile and can be easily damaged.

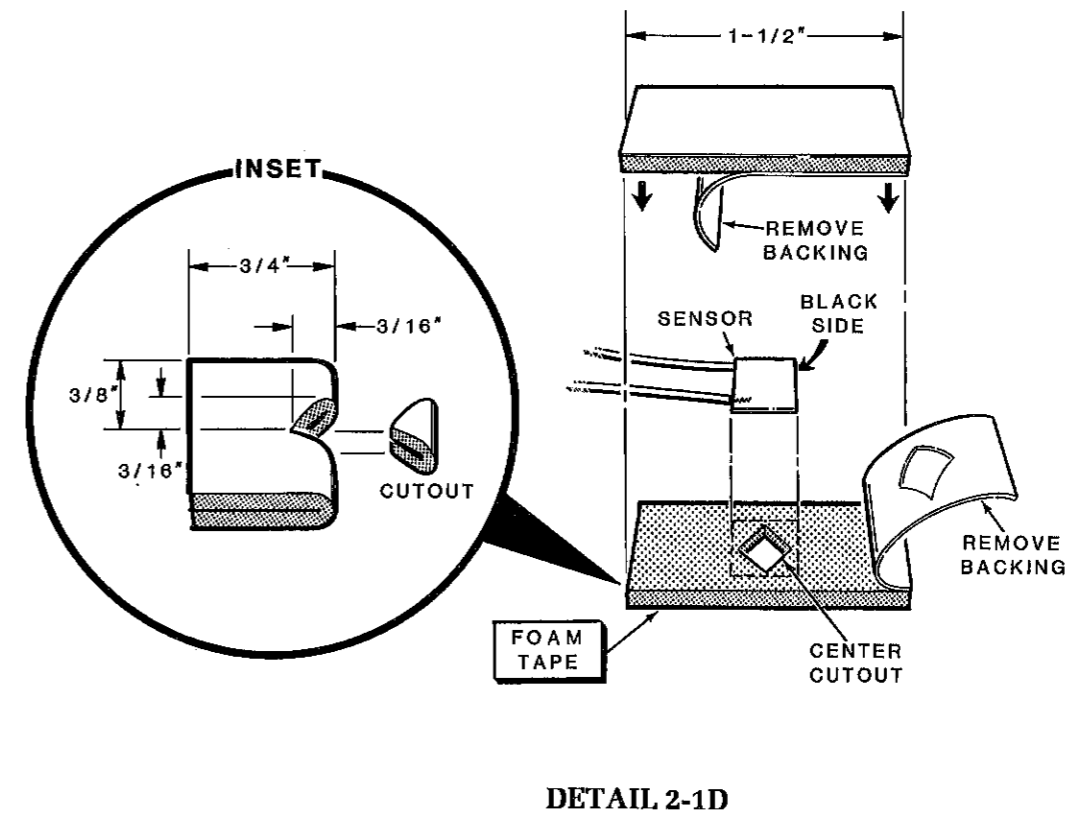

DETAIL 2-1D

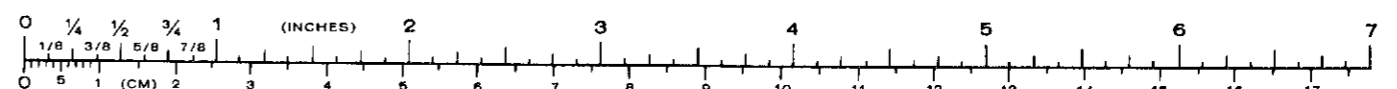



Refer to Pictorial 2-2 (Illustration Booklet, Page 3) for the following steps.

- ( ) Position the assembled circuit board along the right side of the chassis as shown.

NOTE: In the following steps, when you connect a wire to a circuit board hole or to a component lug, solder the connection and cut off any excess wire end.

- ( ) Connect the red wire in the twisted pair coming from the circuit board to switch SW1 lug 2, and the yellow wire to SW1 lug 5. Solder both wires.
- ( ) Connect the remaining battery clip wires as follows: Connect the red wire coming from one clip to SW1 lug 1, and the black wire from the other clip to SW1 lug 6. Solder both wires.
- ( ) Connect one of the green wires in the twisted pair to speaker SP1 lug 1 and the other green wire to SP1 lug 2. Solder both wires.
- ( ) Connect the blue wire in the twisted pair to meter M1 lug 1. Note that lug 1 is the **negative (-)** lug. Connect the white wire to M1 positive (+) lug 2. Solder both wires.

Refer to Pictorial 2-3 (Illustration Booklet, Page 4) for the following steps.

- ( ) Make sure the slide switch is in the OFF position.
- ( ) Locate the battery clip whose red wire comes from circuit board hole D. Push this clip onto a 9-volt transistor battery. Then push the battery down into the battery holder at E2.
- ( ) Push the other battery clip onto a 9-volt transistor battery. Push this battery into the battery holder at E1.
- ( ) Turn the circuit board up on edge, just inside the right side of the chassis, with its component side facing out. Secure the circuit board spacers to the chassis at G and H with two 6-32 × 3/8" flat head screws.

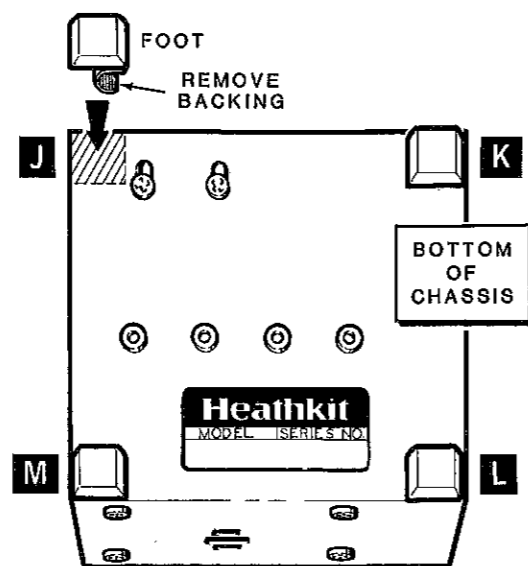

PICTORIAL 2-4

- ( ) Tightly twist the two sensor wires together. Then install the red wire in circuit board hole A and the black wire in hole B. Solder each wire to the foil and cut off the excess wire ends.

Refer to Pictorial 2-4 for the following steps.

- ( ) Position the chassis assembly bottom side up on your work area as shown.
- ( ) Remove the paper backing from one of the feet and press the foot in place at one corner of the chassis at J as shown.
- ( ) In the same manner, install feet on the bottom of the chassis at K, L, and M.
- ( ) Remove the paper backing from the blue and white label and press the label in place on the bottom of the chassis as shown. NOTE: Be sure to refer to the Model and Series numbers on the blue and white label in any correspondence you have with the Heath Company about your kit.

Except for the installation of the cabinet top, this completes the "Step-by-Step Assembly" of your Laser Receiver. Proceed to "Initial Tests."

## INITIAL TESTS

Refer to Pictorial 3-1 for the following steps.

- ( ) Position the Laser Receiver on your work area as shown.
- ( ) Using a small screwdriver, turn the VOL (Volume) and NULL controls fully counterclockwise.
- ( ) Similarly, turn the SENS (Sensitivity) control fully clockwise.

NOTE: In the following steps, if you do not get the desired results, turn OFF the POWER switch. Then refer to the "In Case of Difficulty" section of the Manual. After you have found and corrected your problem, refer again to this section and continue with the tests and adjustments.

- ( ) Push the POWER switch to ON. The meter pointer should deflect upscale.
- ( ) Alternately cover and uncover the SENSOR as you observe the meter; the pointer should change (rise and fall) significantly.
- ( ) With the SENSOR uncovered, adjust the NULL control for a zero meter indication. This compensates for ambient lighting.

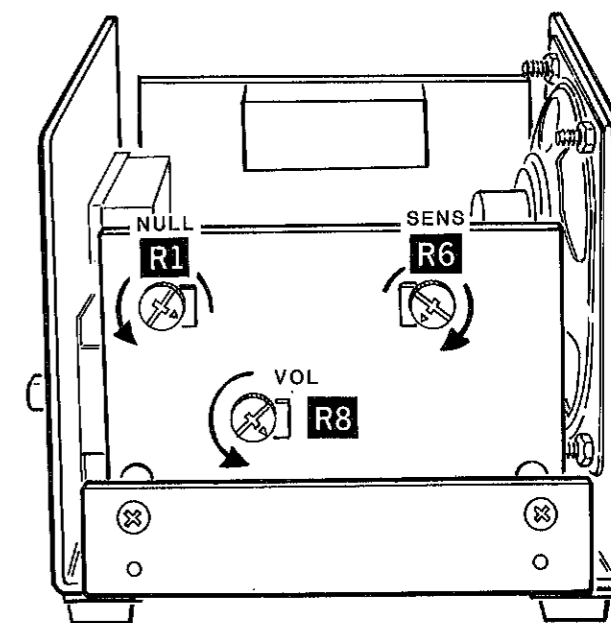

PICTORIAL 3-1

- ( ) Turn the VOL control fully clockwise.
- ( ) Place the Laser Receiver near a flickering light source, such as a fluorescent light or a TV receiver. The Laser Receiver should produce a buzzing sound.
- ( ) Push the POWER switch to OFF.

## FINAL ASSEMBLY

Refer to Pictorial 3-2 for the following steps.

- ( ) Place the Laser Receiver on your work area as shown.
- ( ) Place the cabinet top down over the chassis assembly with the SENSOR opening in the side panel over the sensor in the chassis. Secure the cabinet top to the chassis assembly with four #6 × 3/8" sheet metal screws.

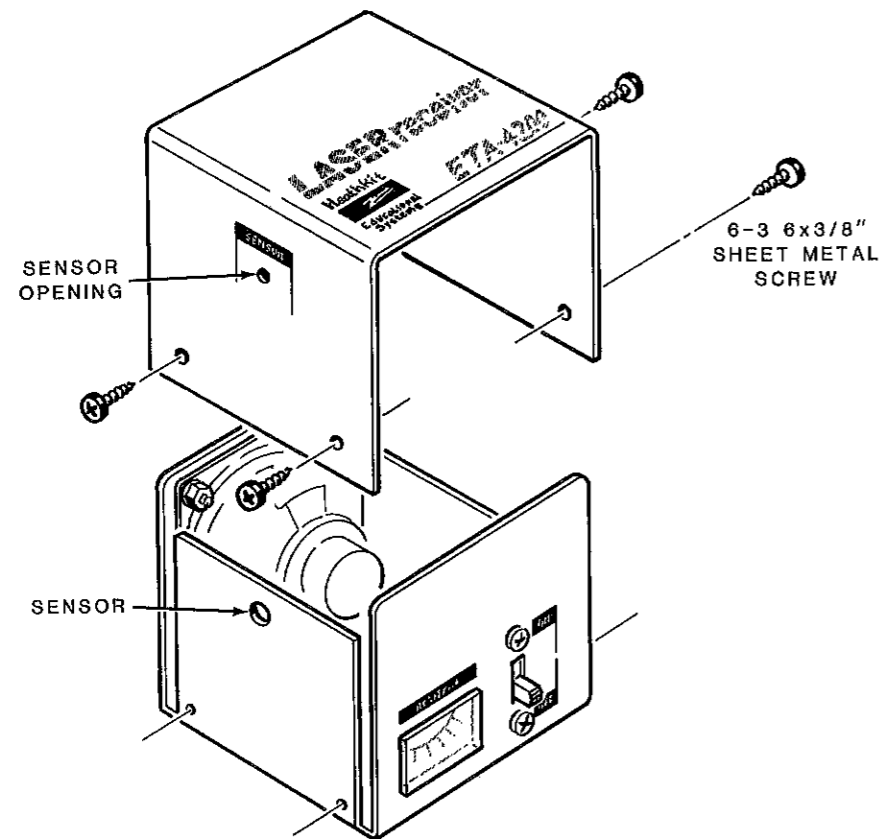

PICTORIAL 3-2

## ADJUSTMENTS

Refer to Pictorial 4-1 (Illustration Booklet, Page 4) for the following steps.

**WARNING: In the following steps, when you make any adjustments or reposition either component take extra precautions to avoid looking into the laser beam.**

- ( ) Close the Trainer aperture; then adjust the Receiver NULL control for a meter indication of zero.
- ( ) Open the Trainer aperture and adjust the Receiver SENS control for a meter reading of 10.
- ( ) Turn off the power on both the Receiver and the Trainer.
- ( ) Refer to Detail 4-1A and, using a small screwdriver, turn the NULL and SENS controls to the centers of their rotation. Turn the VOL control fully counterclockwise.
- ( ) Position the Trainer approximately 12" from the Receiver. Open the aperture on the Trainer, and position the laser ray so it is centered on the SENSOR opening on the Receiver.
- ( ) Turn the Receiver POWER switch ON.

This completes the "Adjustments" of your ETA-4200 Laser Receiver. Further adjustments and the operation of your Laser Trainer and Receiver are covered in the Heathkit Continuing Education Laser Course. Refer to that text for complete details.

### IN CASE OF DIFFICULTY

The first part of this section of the Manual, titled "Visual Checks," tells you what to do about any difficulties that occur right after your unit is assembled.

If the "Visual Checks" fail to clear up the problems, or if difficulties occur after your unit has been in use for some time, refer to the "Troubleshooting Chart."

NOTE: Refer to the "Circuit Board X-Ray View" for the physical location of parts.

#### VISUAL CHECKS

1. Recheck the wiring. Trace each lead with a colored pencil on the Pictorial as you check it. It is frequently helpful to have a friend check your work. Someone who is not familiar with the unit may notice something you have consistently overlooked.
2. About 90% of the kits that are returned to the Heath Company for service do not function properly due to poor connections and soldering. Therefore, you can eliminate many troubles by reheating all connections to make sure they are soldered as described in the "Soldering" instructions on Pages 4, 8, and 10.
3. Closely examine the circuit board foil in a good light to see that no solder bridges exist between adjacent connections. Remove any solder bridges by holding a clean, hot soldering iron tip between the two points that are

bridged until the excess solder flows down onto the tip. Compare your foil patterns with those in the "Circuit Board X-Ray View."

4. Check each capacitor value. Make sure that a capacitor of the correct value is installed at each capacitor location. Check electrolytic capacitors to be sure their positive (+) and negative (-) leads are at the correct positions.
5. Check each resistor value carefully. Be sure in each step that the proper part has been wired into the circuit as shown in the Pictorial diagrams. It would be easy, for example, to install a 4700Ω (yel-viol-red) resistor where a 470 kΩ (yel-viol-yel) resistor should have been installed.
6. Be sure all the wires and leads connected to the circuit boards have been trimmed as close as possible to the circuit board foils.
7. Check for bits of solder, wire ends, or other foreign matter which may be lodged in the wiring.

If you still have not located the trouble after the "Visual Checks" are completed, and if a voltmeter is available, check the voltage readings at the locations indicated on the Schematic diagram. NOTE: All voltage readings were taken with a high-input impedance voltmeter. Voltages may vary slightly, up to ±10%.

NOTE: In an extreme case where you are unable to resolve a difficulty, refer to the "Customer Service" information inside the rear cover of this Manual. Your Warranty is located inside the front cover.

### Troubleshooting Chart

Problem	Possible Cause
Meter deflects in wrong direction	1. NULL control incorrectly adjusted. 2. Meter or sensor incorrectly wired.
Unable to obtain correct NULL adjustment.	1. Ambient lighting too bright. 2. Weak batteries.
No audio at any time.	1. VOL control incorrectly set. 2. Integrated circuit U2.
Audio output distorted.	1. Modulating signal overdriving input of Laser Trainer unit. 2. Laser Trainer OSC control not properly adjusted. 3. Batteries weak.

## SPECIFICATIONS

Meter Reading .....	Directly proportional to intensity of coherent light emitted by Laser Trainer unit.
Audible Output .....	Reproduces modulation of light incident on its sensor.
Power Requirement .....	Two series-connected Type 1604 9-volt DC batteries.
Dimensions (overall) .....	3.5" H = 4.25" W = 4" D. (8.9 = 10.8 = 10.2 cm).
Net Weight .....	1.2 lbs. (0.54 kg).

The Heath Company reserves the right to discontinue products and to change specifications at any time without incurring any obligation to incorporate new features in products previously sold.

## CIRCUIT DESCRIPTION

Refer to the Schematic Diagram as you read the following circuit description.

## INPUT CIRCUITRY

Sensor A1 is a photovoltaic cell which is sensitive to light on its surface. It produces an output current proportional to the instantaneous peak power of the incident light. Its output current is routed to the input of a non-inverting current-to-voltage converter circuit consisting of integrated circuit U1A and resistors R3 and R4.

Null control R1 and resistor R2 provide balancing currents which cancel the effect of any ambient light. You will adjust the Null control so that, when normal ambient light falls on sensor A1 and no laser beam is present, the output of IC U1A is zero volts.

## METER CIRCUITRY

IC U1B, resistor R5, and Sensitivity control R6 form an inverting voltage amplifier. The Sensitivity control adjusts the gain of the amplifier, controlling the amount of meter deflection per unit of beam intensity. Resistor R7 limits the current from the amplifier through meter M1.

## AUDIO CIRCUITRY

Any fluctuations in the laser beam's intensity, such as amplitude modulating signals, are coupled from the input circuits to the Volume control through capacitor C3. The center tap of R6 is connected to the input of audio amplifier IC U2.

Capacitor C4 is a bypass capacitor to decouple the input of IC U2. Capacitor C5 and resistor R9 form a compensation network which regulates the amplifier's frequency response.

CIRCUIT BOARD  
X-RAY VIEW

NOTE: To find the PART NUMBER of a component for the purpose of ordering a replacement part:

- Find the circuit component number (R5, C3, etc.) on the X-Ray View.
- Locate this same number in the "Circuit Component Number" column of the "Parts List" in the front of this Manual.
- Adjacent to the circuit component number, you will find the PART NUMBER and DESCRIPTION which must be supplied when you order a replacement part.

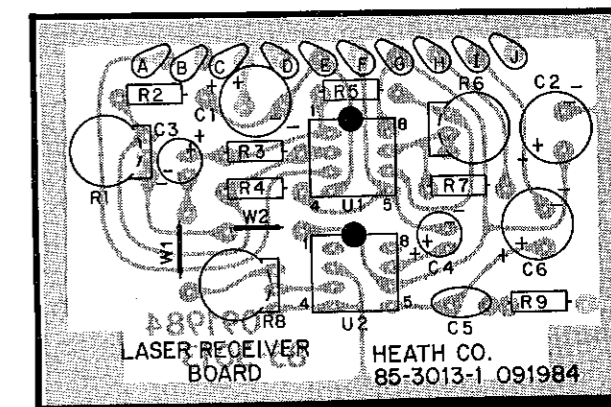

### SEMICONDUCTOR IDENTIFICATION CHART

CIRCUIT COMPONENT NUMBER	HEATH PART NUMBER	MAY BE REPLACED WITH	IDENTIFICATION (TOP VIEW)
U1	442-21	MC1458	
U2	442-612	LM386N	

### SCHEMATIC OF THE LASER RECEIVER Model ETA-4200

NOTES:

- ALL RESISTORS ARE 1/4-WATT, 5% TOLERANCE UNLESS OTHERWISE NOTED. (K=1000, M=1,000,000.)
- CAPACITORS LESS THAN 1 ARE IN  $\mu\text{F}$  (MICROFARADS); 1 OR GREATER ARE IN pF, UNLESS OTHERWISE NOTED.
- THE FOLLOWING SYMBOLS ARE USED ON THIS SCHEMATIC:
  - THIS SYMBOL DENOTES A CIRCUIT BOARD GROUND.
  - THIS SYMBOL DENOTES A CIRCUIT BOARD WIRE CONNECTION.
  - THIS SYMBOL DENOTES A DC VOLTAGE TAKEN WITH A HIGH-INPUT IMPEDANCE VOLTMETER FROM THE POINT INDICATED TO CIRCUIT BOARD GROUND.
- TO FIND THE PHYSICAL LOCATION OF PARTS, REFER TO THE "CIRCUIT BOARD X-RAY VIEW" ON MANUAL PAGE 24.

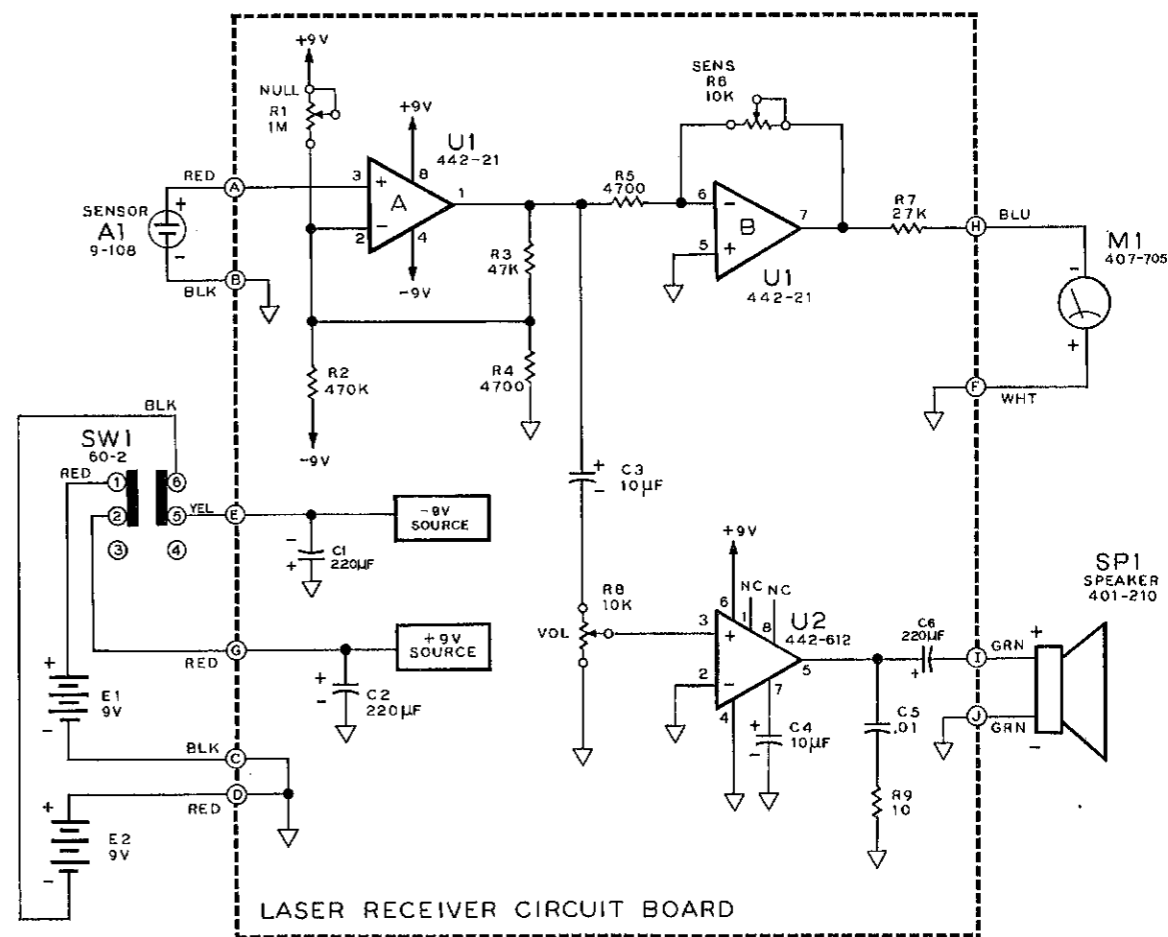



**HEATH COMPANY • BENTON HARBOR, MICHIGAN**  
***THE WORLD'S FINEST ELECTRONIC EQUIPMENT IN KIT FORM***

LITHO IN U.S.A.