

# ASSEMBLY AND OPERATION OF THE HEATHKIT CODE PRACTICE OSCILLATOR MODEL CO-1

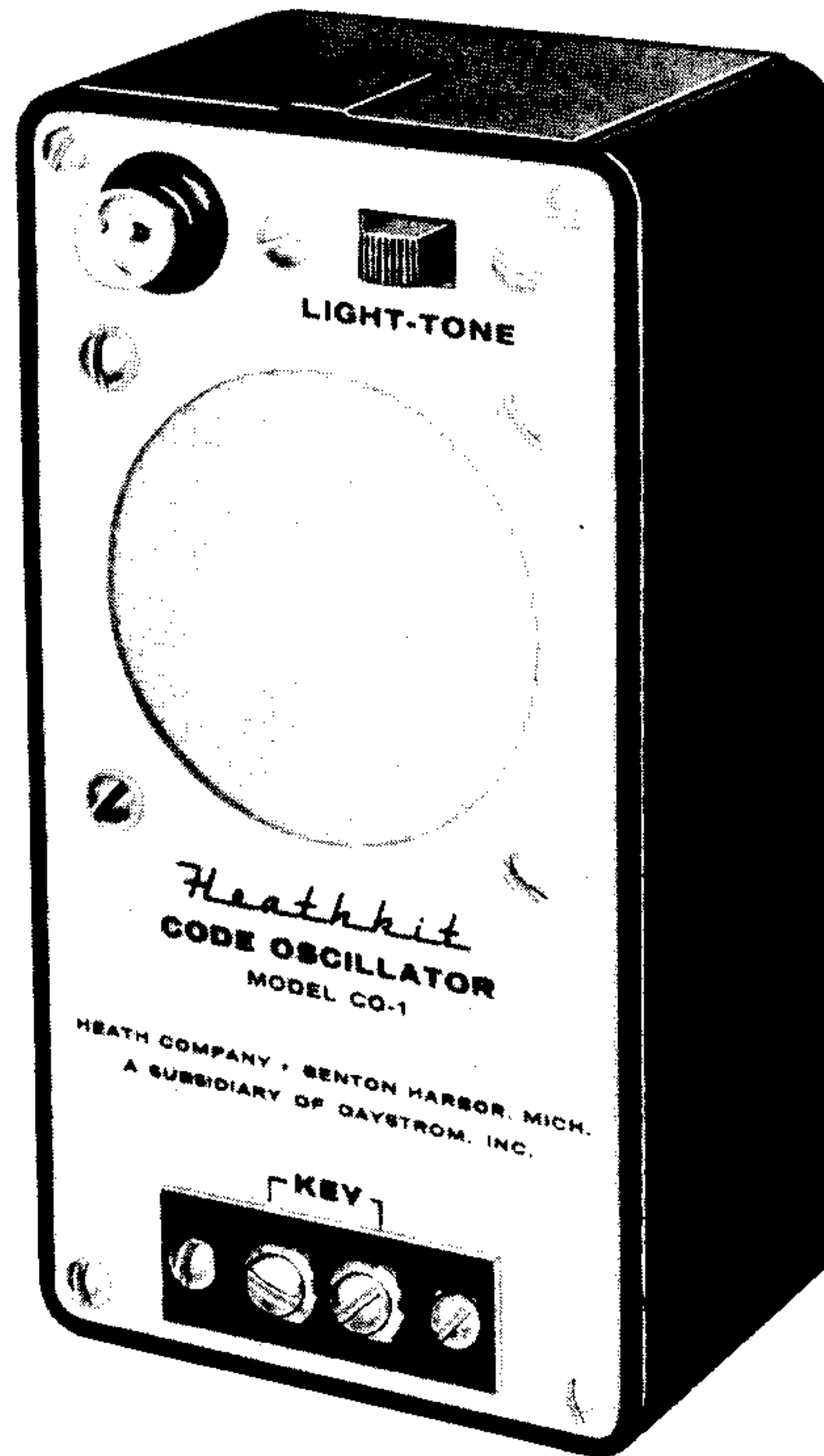

## SPECIFICATIONS

- Tone Frequency:..... Approximately 1000 cycles per second.
- Controls:..... Tone or light switch.
- Current Drain (Light):..... 300 milliamperes at 3 volts DC.
- Current Drain (Tone):..... Approximately 10 milliamperes at 3 volts DC.
- Case Size:..... 6" long, 3" wide, 2 1/8" deep.
- Net Weight:..... 1 lb. 3 oz.
- Shipping Weight:..... 2 lbs.

## INTRODUCTION

The Heathkit Model CO-1 Code Practice Oscillator is a combination tone oscillator-flashing light signaling device, designed to be used for the teaching of the Morse Code.

Novice Radio Amateurs and Boy Scouts, as well as many other groups of radio enthusiasts, are required to attain a given speed in Morse Code sending and receiving in order to qualify in their examinations. The Heathkit Model CO-1 is a very practical unit when learning the code, as a teaching unit and as a means of practicing this teaching. It should give years of service.

Being a construction kit, the CO-1 also offers the novice an opportunity to gain some experience with transistor circuitry. The basic design is of maximum simplicity and compactness. Mechanically it features a ruggedness that should withstand much abuse. This would allow the Model CO-1 to be packed with other necessities for cross-country jaunts that are so often enjoyed by Boy Scout groups.

While the distance covered by the tone is somewhat limited, after dark the flashing light signals may be seen a great distance. In this latter respect, much enjoyable communication could be established between groups, which would no doubt result in added incentive toward signaling as a whole.

The mechanics of the circuit and its theory may pose a slight problem for some of the younger experimenters, at which time the assistance of a more experienced person could be enlisted. Perseverance will be rewarded by the satisfaction gained upon completion of the kit.

When properly constructed as outlined in the manual, ample clearance will be provided for inserting the finished assembly into the bakelite case.

The values of resistance and capacity in the circuit have been chosen to provide a pleasing tone. There will be some variation in the frequency of this tone with some transistors, but generally it will be within reasonable limits.

## CIRCUIT DESCRIPTION

The transistorized Code Practice Oscillator employs a PNP transistor in a "blocking oscillator" circuit, using the common emitter configuration. The only necessary power is provided by two size "C" batteries which supply 3 volts to operate the transistor oscillator or light. A terminal strip provides connections for a key, which initiates the tone or light signals.

In operation, a push-pull type output transformer, T1, serves the dual purpose of providing the necessary feedback to start and sustain oscillation, and at the same time matches the transistor's high output impedance to the low impedance speaker voice coil.

The repetition rate, or frequency of oscillation, is determined by the RC time constant of coupling capacitor C1 and the base resistor, which includes resistor R1 and the "beat rate" resistor R2. Changing the value of resistor R2 changes the RC time constant, and thus changes the operating rate or frequency of oscillation; in effect, the pitch of the audible tone is raised or lowered.

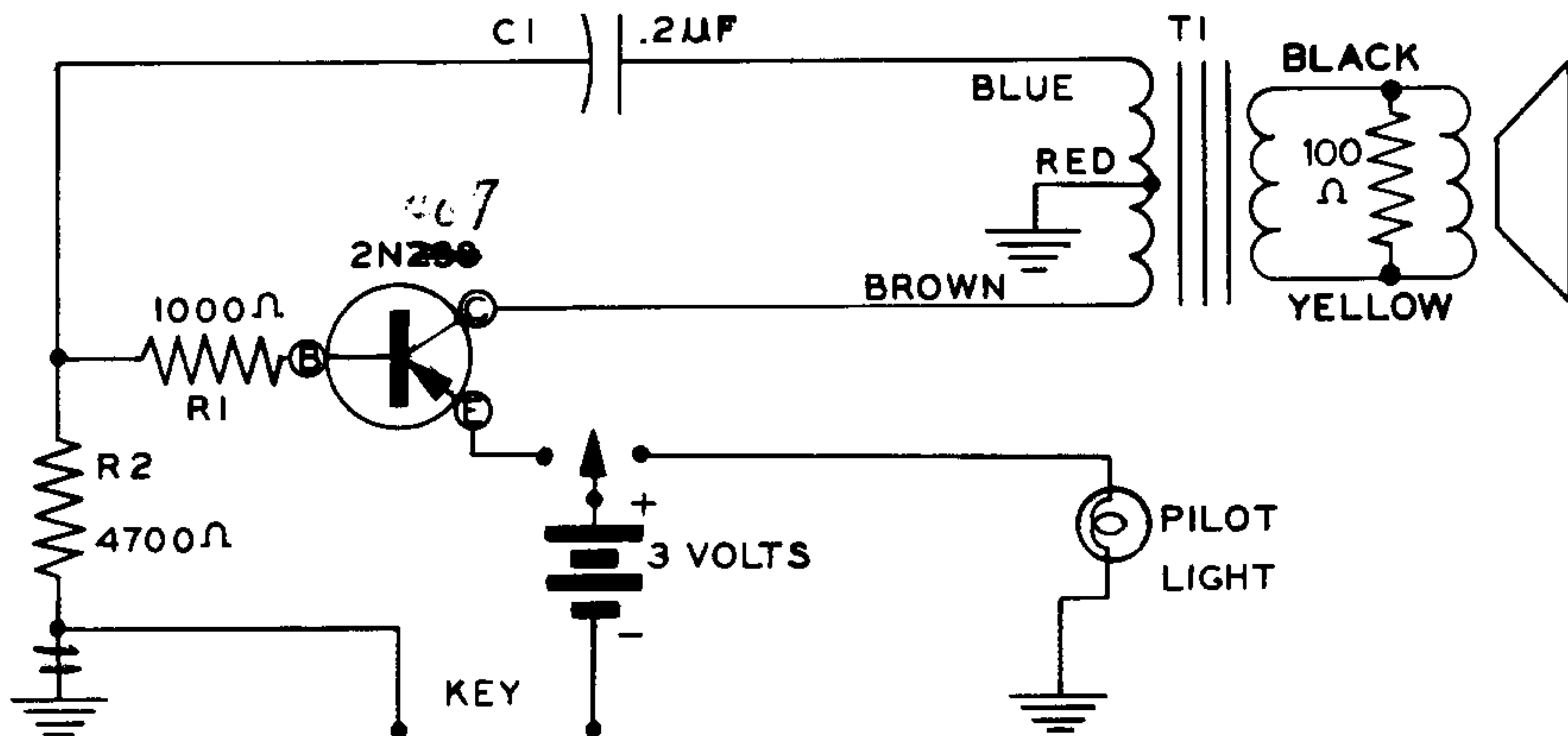

### CONSTRUCTION NOTES

This manual is supplied to assist you in every way to complete your kit with the least possible chance for error. While the arrangement shown is probably not the only satisfactory arrangement, nevertheless it is the result of extensive experimentation and trial. If followed carefully, it will result in a stable instrument which is rugged and dependable. We suggest that you retain the manual in your files for future reference, both in the use of the instrument and for its maintenance.

UNPACK THE KIT CAREFULLY AND CHECK EACH PART AGAINST THE PARTS LIST on Page 19. In so doing, you will become acquainted with them. Refer to parts illustrations on Page 19 to help you identify these components. If some shortage is found in checking the parts, please notify us promptly and return the inspection slip with your letter to us.

### PROPER SOLDERING TECHNIQUES

Only a small percentage of Heathkit purchasers find it necessary to return an instrument for factory service. Of these instruments, by far the largest proportion of malfunctions are due to poor or improper soldering.

If terminals are bright and clean and free of wax, frayed insulation and other foreign substances, no difficulty will be experienced in soldering. Correctly soldered connections are essential if the performance engineered into a kit is to be fully realized. If you are a beginner with no experience in soldering, a half hour's practice with some odd lengths of wire may be a worthwhile investment.

For most wiring, a 30 to 100 watt iron or its equivalent in a soldering gun is very satisfactory. A lower wattage iron than this may not heat the connection enough to flow the solder smoothly over the joint. Keep the iron tip clean and bright by wiping it from time to time with a piece of cloth.

### CHASSIS WIRING AND SOLDERING

1. Crimp or bend the lead (or leads) around the lug or terminal to form a good joint without relying on solder for physical strength. If the wire is too large to allow bending, position the wire so that a good solder connection can still be made.

2. Position the work, if possible, so that gravity will tend to keep the solder where you want it.
3. Place a flat side of the soldering iron tip against the joint to be soldered until it is heated sufficiently to melt the solder.
4. Place the solder against the heated terminal and it will immediately flow over the joint; use only enough solder to thoroughly wet the junction. It is usually not necessary to fill the entire hole in the terminal with solder.
5. Remove the solder and then the iron from the completed junction. Use care not to move the leads until the solder is solidified.

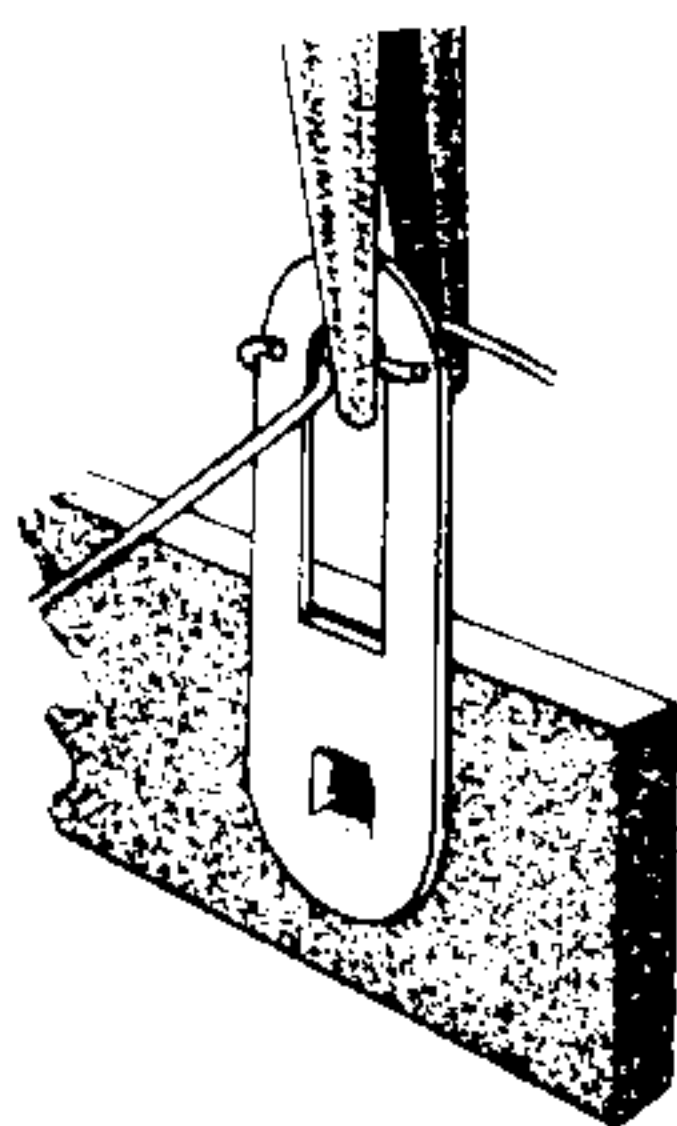

CRIMP WIRES

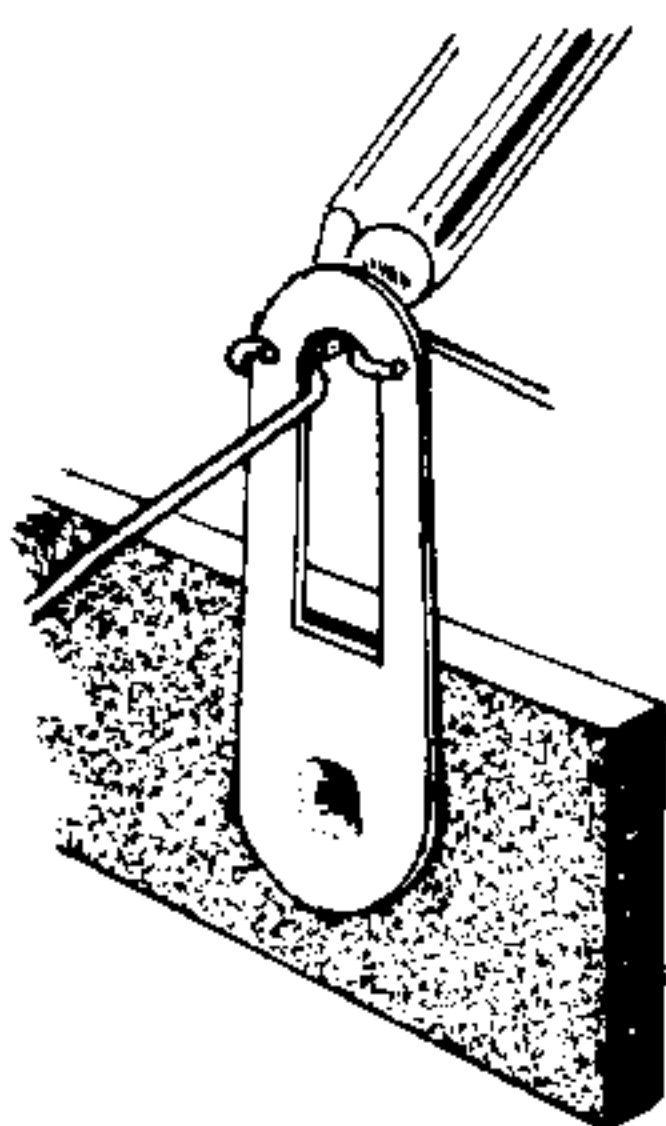

HEAT CONNECTION

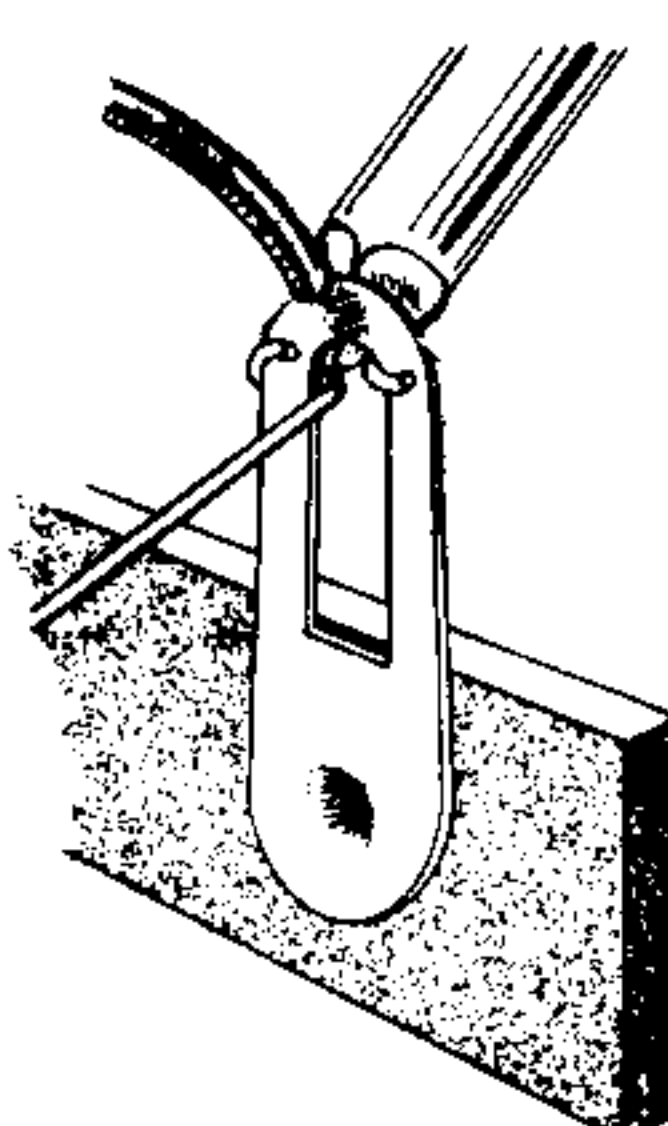

APPLY SOLDER

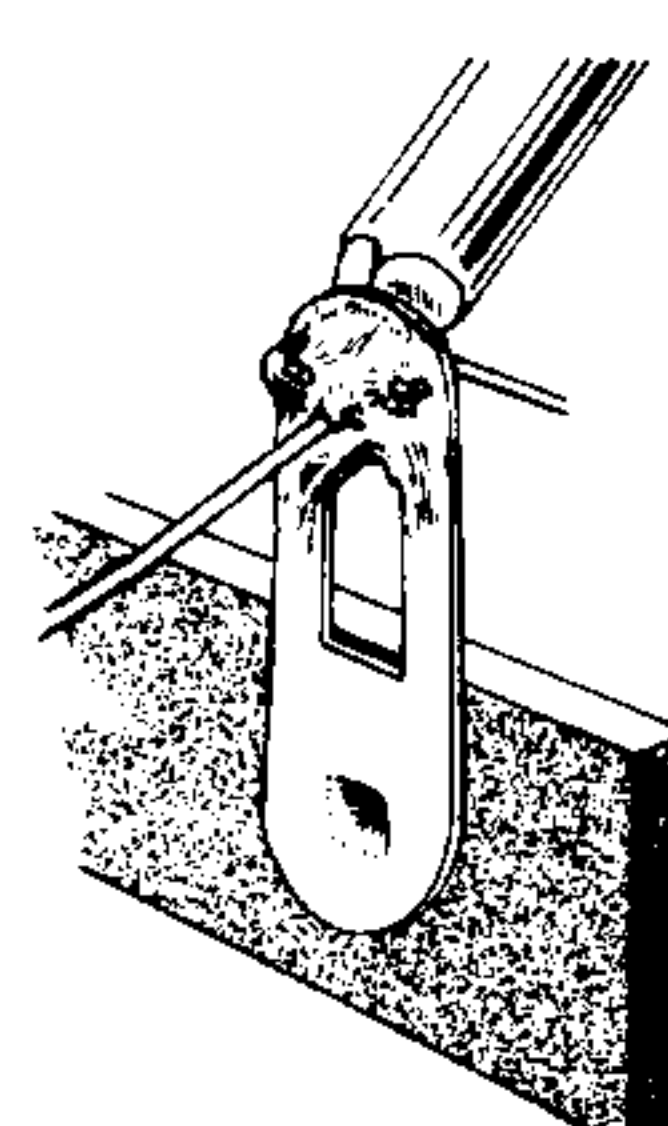

ALLOW SOLDER  
TO FLOW

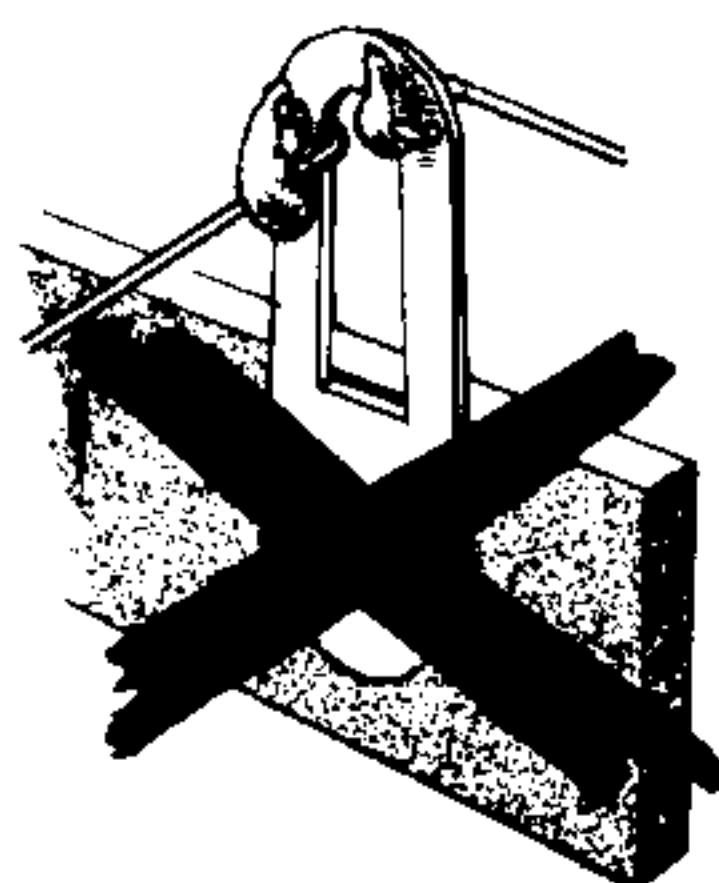

COLD SOLDER JOINT  
CONNECTION INSUFFICIENTLY  
HEATED

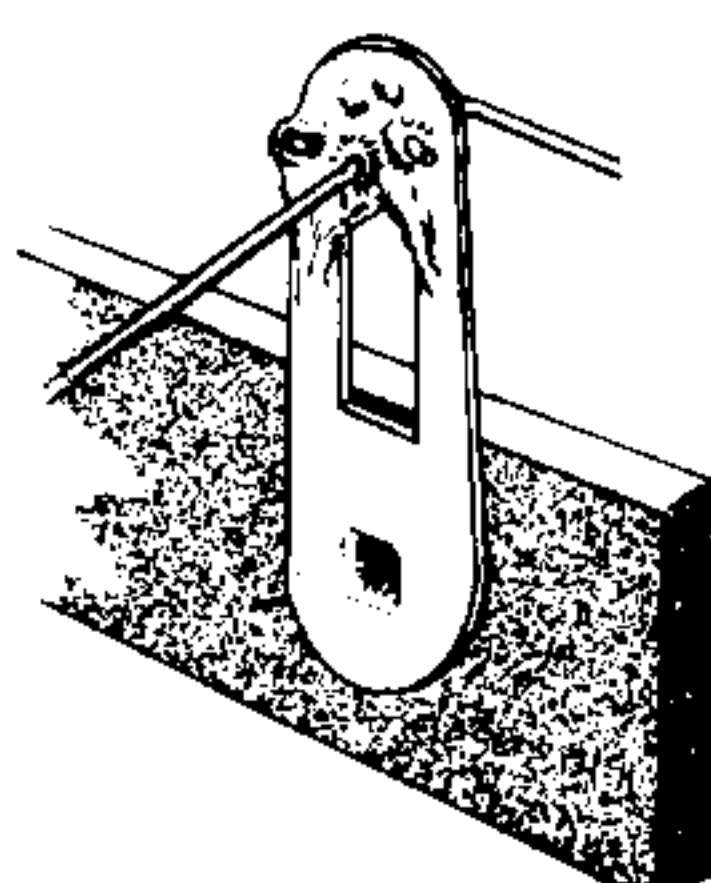

PROPER SOLDER  
CONNECTION

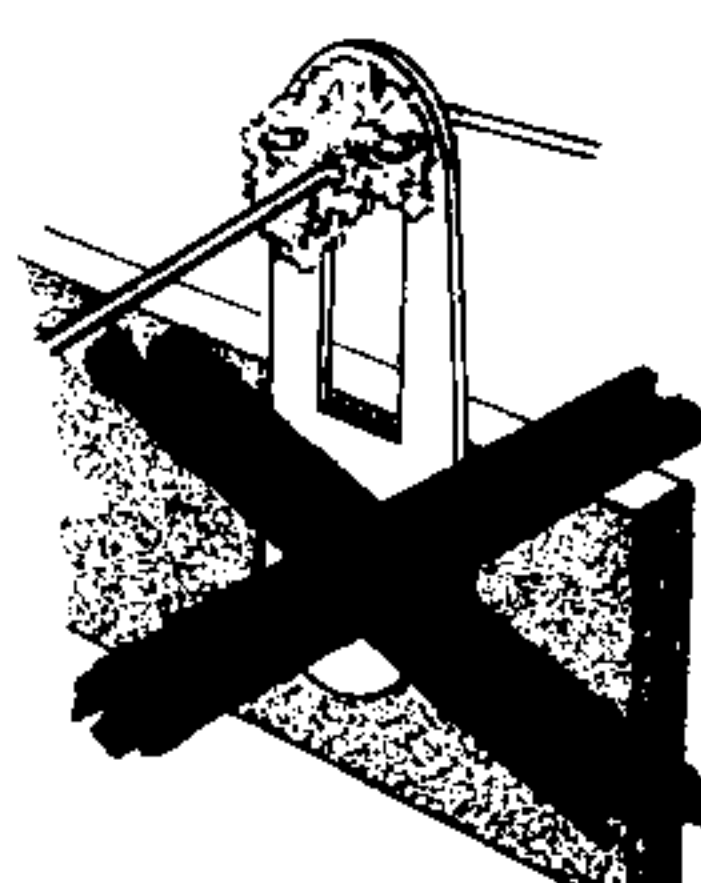

COLD SOLDER JOINT  
CONNECTION MOVED  
WHILE COOLING

A poor or cold solder joint will usually look crystalline and have a grainy texture, or will stand up in a blob and will not have adhered to the joint. Such joints should be reheated until the solder flows smoothly over the entire junction. In some cases, it may be necessary to add a little more solder to achieve a smooth, bright appearance.

ROSIN CORE SOLDER HAS BEEN SUPPLIED WITH THIS KIT. THIS TYPE OF SOLDER MUST BE USED FOR ALL SOLDERING IN THIS KIT. ALL GUARANTEES ARE VOIDED AND WE WILL NOT REPAIR OR SERVICE EQUIPMENT IN WHICH ACID CORE SOLDER OR PASTE FLUXES HAVE BEEN USED. IF ADDITIONAL SOLDER IS NEEDED, BE SURE TO PURCHASE ROSIN CORE (60:40 or 50:50 TIN-LEAD CONTENT) RADIO TYPE SOLDER.



We suggest that you do the following before work is started:

1. Read several steps ahead of the actual step being performed. This will familiarize you with the relationship of the subsequent operations.
2. Lay out all parts so that they are readily available.
3. Provide yourself with good quality tools. Basic tool requirements consist of a screwdriver with a 1/4" blade; a small screwdriver with a 1/8" blade; long-nose pliers; wire cutters, preferably separate diagonal cutters; a pen knife or a tool for stripping insulation from wires; a soldering iron (or gun) and rosin core solder. A 1/4" (#8) and a 5/16" (#10) nut driver and a nut starter, while not necessary, will aid extensively in construction of the kit.

### STEP-BY-STEP PROCEDURE

The following instructions are presented in a simple logical step-by-step sequence to enable you to complete your kit with the least possible confusion. Be sure to read each step all the way through before beginning. When the step is completed, check it off in the space provided. This is particularly important as it may prevent errors or omissions, especially if your work is interrupted.

The abbreviation "NS" indicates that a connection should not be soldered as yet because one or more other wires will be added. When the last wire is installed, the terminal should be soldered and the abbreviation "S" is used to indicate this. Note that a number will appear after each solder instruction. This number indicates the number of leads that should be connected to the terminal before it is soldered. For example, if the instruction reads, "Connect one lead of a 47 K $\Omega$  resistor to lug 1 (S-2)", it will be understood that there should be two leads connected to lug 1 at the time it is soldered. This additional check will help avoid errors.

### STEP-BY-STEP

Before proceeding with the construction, the various components and hardware should be sorted out. An egg carton, or small boxes, would be convenient for isolating the small parts but if none are available, separating the components into individual groups on the working surface will suffice.

Locate the four #4 lockwashers (see parts illustrations on Page 20) which are to be used with the four 4-40 screws. These are the smaller of the lockwashers and they will not go on a 6-32 screw. A good practice would be to identify the four smaller 4-40 screws, then take one of the screws and slip the four #4 lockwashers onto it, secured with a 4-40 nut. All 4-40 hardware, the nuts and screws with the #4 lockwashers, should be grouped together.

Identification of the remaining hardware should be no problem.

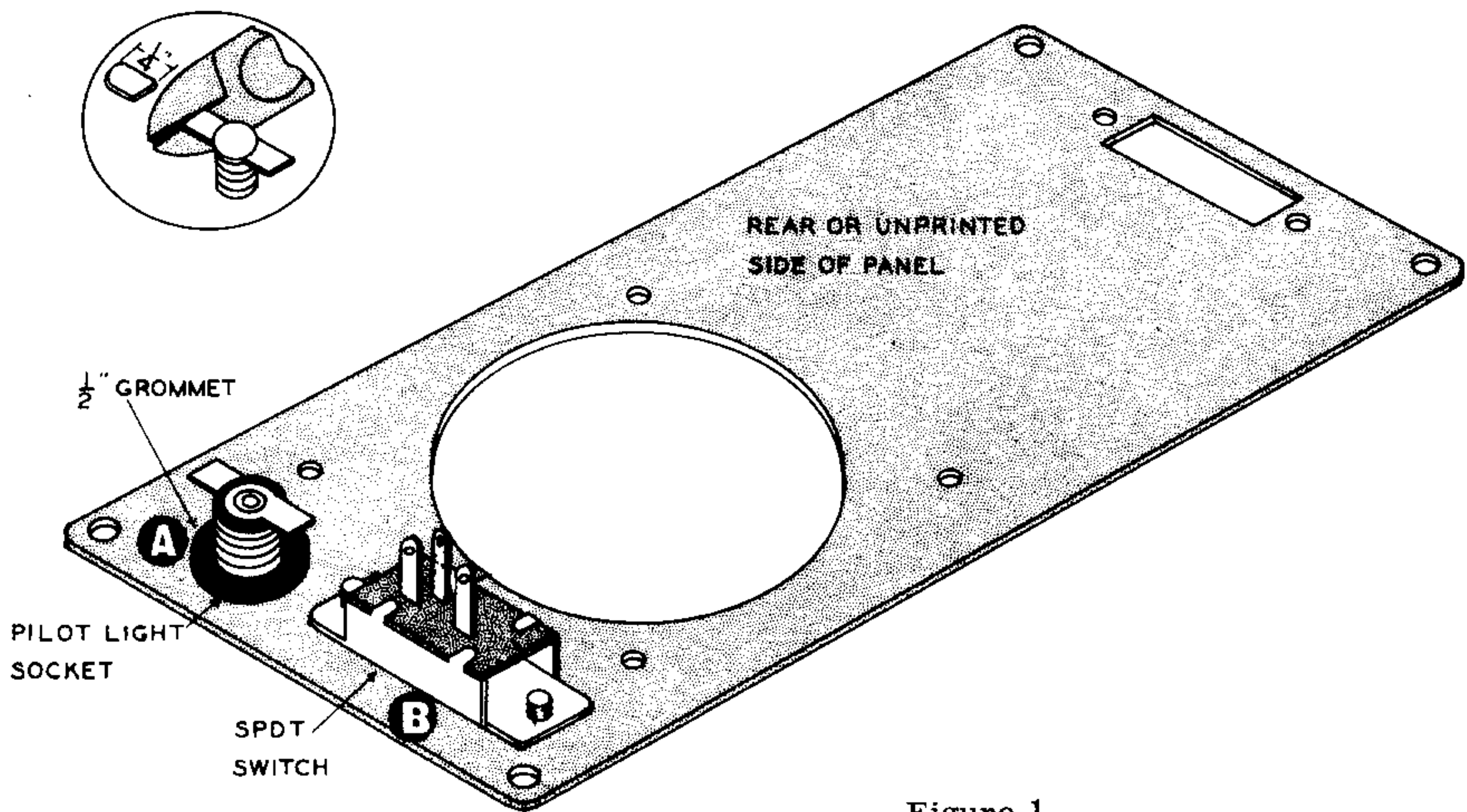

Figure 1

### PRELIMINARY PANEL ASSEMBLY

- ( ) Mount the 1/2" rubber grommet in hole A. Refer to Figure 1.
- ( ) Clip 1/4" off each terminal lug on the pilot light socket, as shown in the same figure.
- ( ) Moisten the inside edge of the 1/2" grommet with soapy water, or a similar slippery substance. From the rear side of the panel, work the pilot light socket through the grommet until it emerges flush with the grommet on the front side of the panel. Rotate the socket until the terminals face as shown in Figure 1.
- ( ) Mount the SPDT (Single Pole Double Throw) slide switch in hole B with the center terminal of the switch facing toward the large speaker hole. A nut and lockwasher is not necessary. Use two 6-32 x 1/4" BHMS (Binder Head Machine Screws). See Figure 1.

### TRANSFORMER TO SPEAKER ASSEMBLY

- ( ) Refer to Figure 2 and trim the black and yellow leads of the output transformer (#51-46) to 2 1/2" long. Trim the red and brown leads to 2" long and the blue to 2 3/8" long. Now trim the insulation 3/8" off the end of each lead. Twist the strands tightly together and tin lightly (apply a small amount of solder using a hot iron). Set the transformer aside for now.

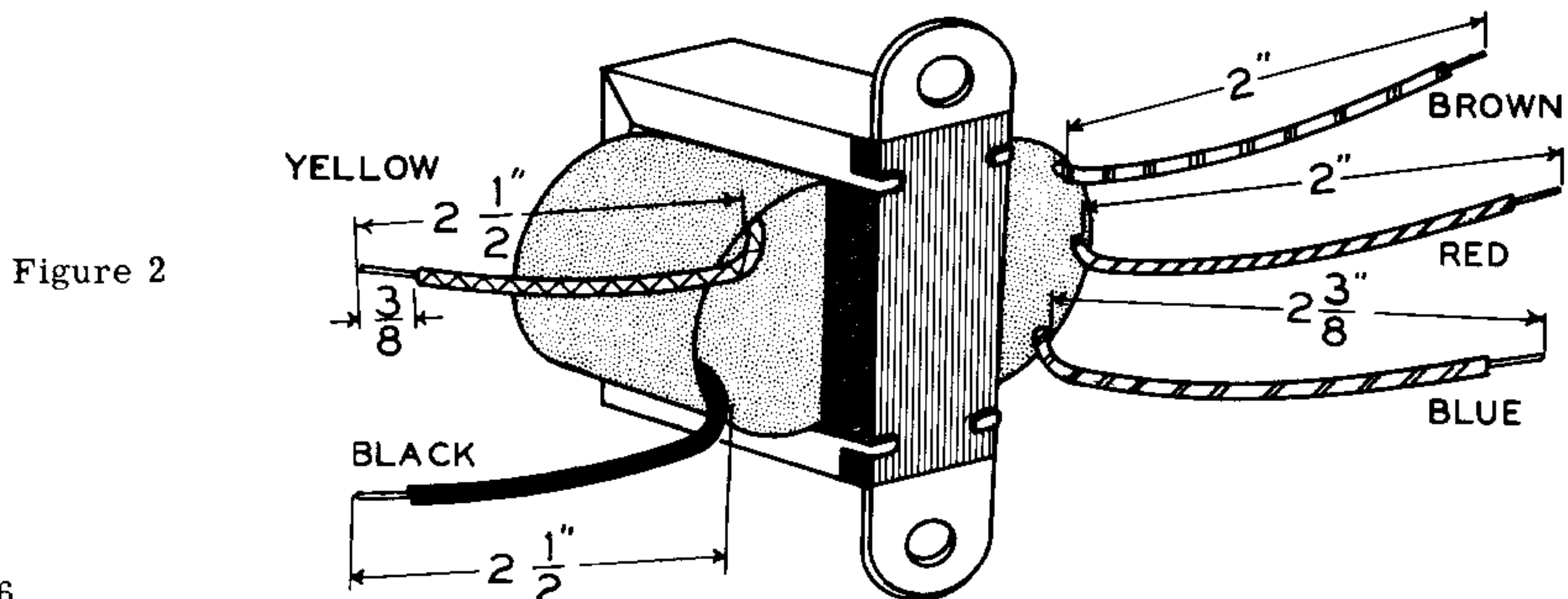

Figure 2

- ( ) Refer to Figure 3 and insert a 6-32 x 3/4" RHMS (Round Head Machine Screw) first through the transistor L bracket, then insert the transistor socket in the bracket with the emitter and base connections next to the screw head. With the transistor socket in the L bracket, turn it upside down and force the mounting clip onto the socket with the points of narrow-nose pliers until the small spring tabs are retained in the depressions of the socket. Set this assembly aside until required.
- ( ) See Figure 4 and assemble the associated parts; insert a 6-32 x 3/4" RHMS through a 2-lug terminal strip, a #6 lockwasher, the two mounting brackets, the mounting foot of the transformer (3 leads facing up), a #6 lockwasher, a 3-lug terminal strip, another #6 lockwasher, and finally, a 6-32 nut which is screwed on only enough to hold these parts together for the time being.

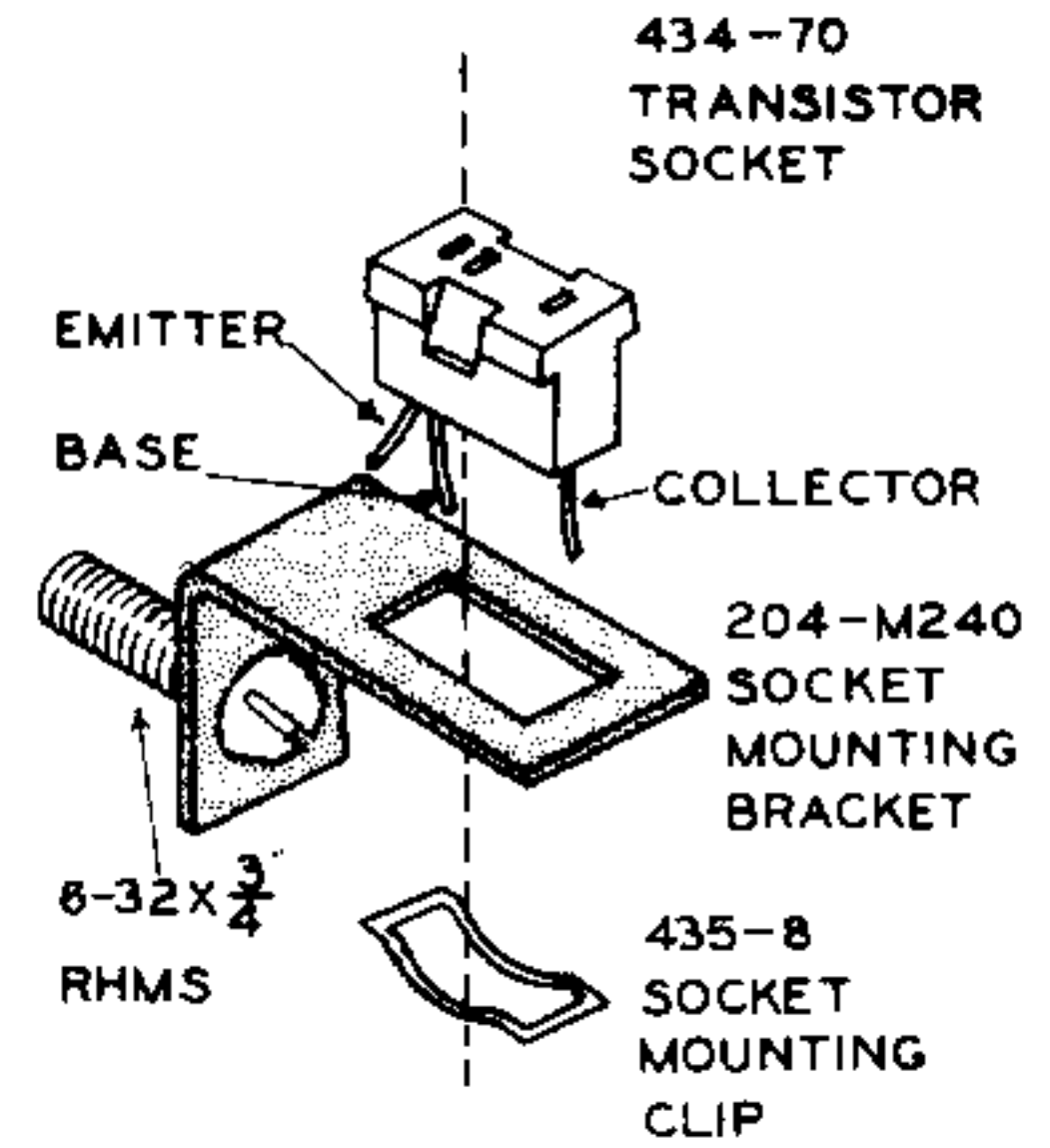

Figure 3

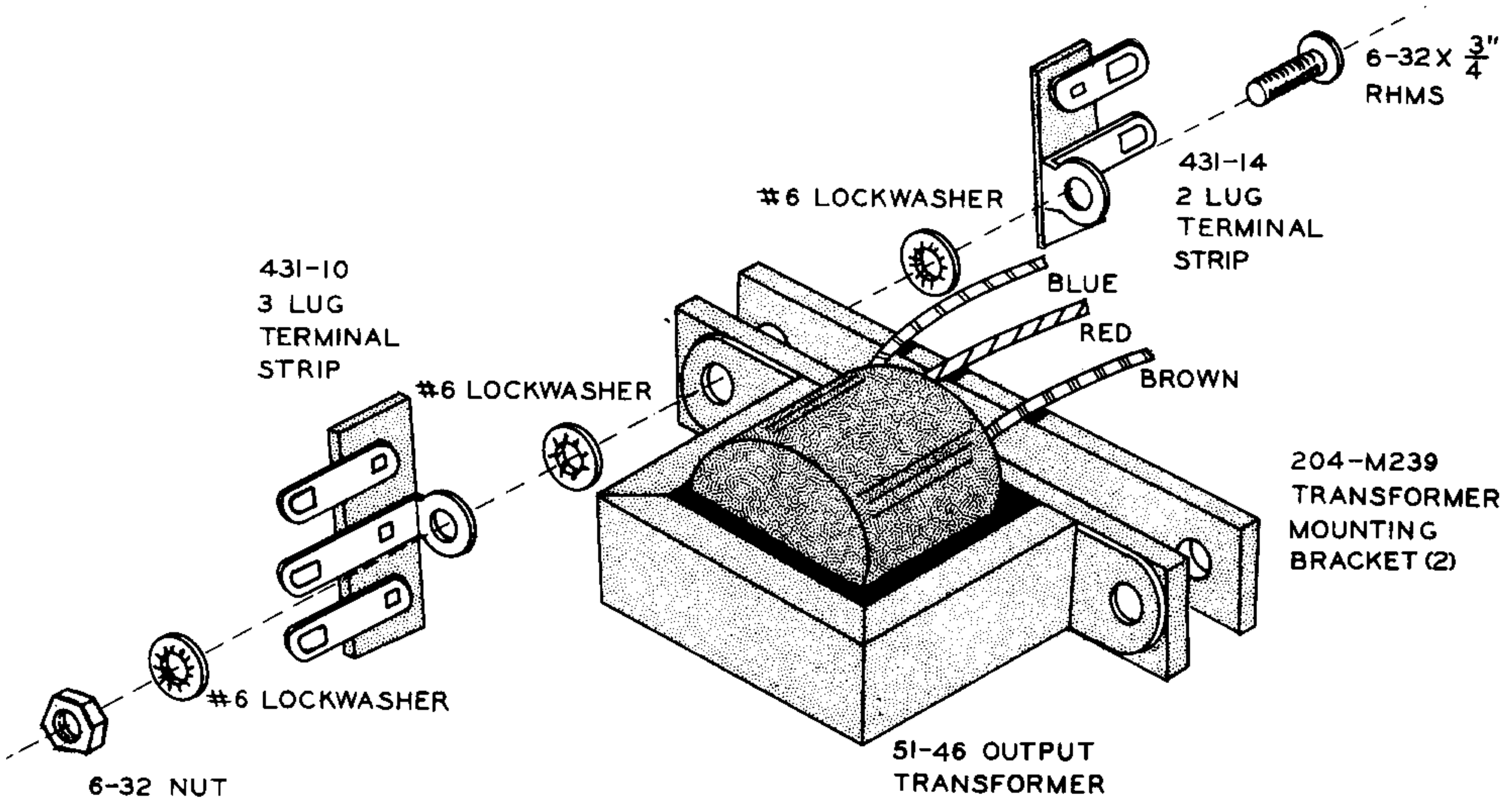

Figure 4

- ( ) Refer to Figure 5 on Page 8 and with the yellow lead on one side of the speaker and the black lead on the other, insert the preceding assembly through the speaker frame on the side away from the voice coil solder lugs. Insert the 6-32 x 3/4" screw (which mounts the transistor socket assembly) through a #6 lockwasher, through the two bracket ends, the transformer foot, a #6 lockwasher, and secure with a 6-32 nut. Do not tighten screws until the center of the transformer is aligned with the center of the speaker. Then, use a thin screwdriver to do the tightening while holding the nut (to avoid damaging the transistor socket).

NOTE: If the assembly is too far to one side, it will not fit into the case.



NOTE:  
3 LEADS OF  
TRANSFORMER  
ON TOPSIDE

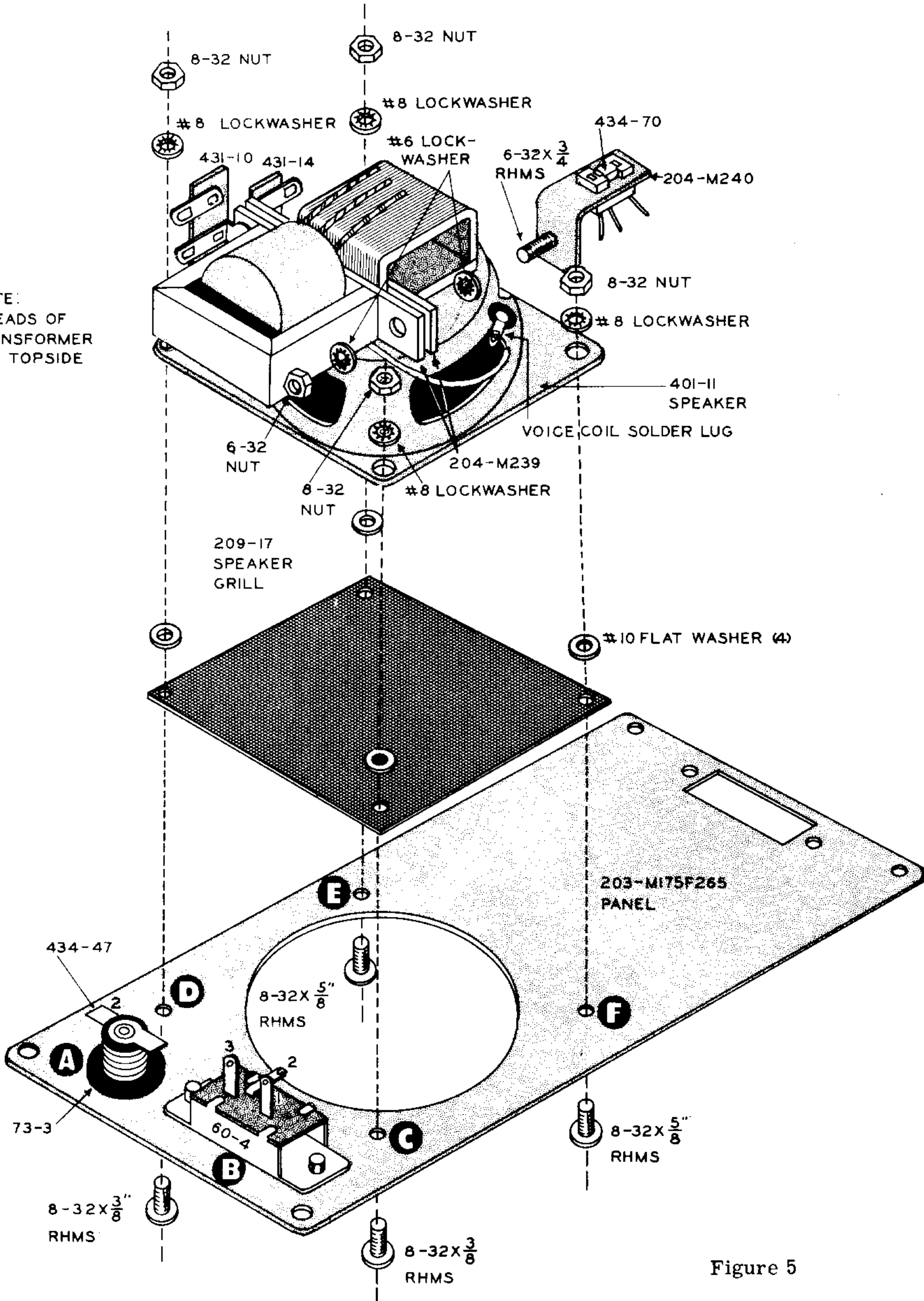

Figure 5



- ( ) Once the transformer is secured to the speaker, connect the black transformer lead to the nearest voice coil solder lug (NS).
- ( ) Connect the yellow transformer lead to the remaining voice coil solder lug (NS).
- ( ) Connect a 100  $\Omega$  (brown-black-brown) 1/2 watt resistor between the voice coil solder lugs. Solder both lugs.

### SPEAKER-TO-PANEL ASSEMBLY

- ( ) Bend the center lug of the SPDT switch down flat and toward the large speaker hole. The other two lugs should be bent outward slightly to clear the output transformer which is mounted in the following steps. Refer to Figure 5.
- ( ) Place the 2 1/2" speaker grill over the large hole in the panel on the panel rear side (with the fuzzy side against the panel). See Figure 5. Insert an 8-32 x 3/8" RHMS through hole C in the panel (the hole next to the switch), through the grill, a flat washer, the speaker frame, a #8 lockwasher and secure with an 8-32 nut. Do not tighten until all the screws are in and the speaker is aligned straight and even with the panel.
- ( ) Insert another 8-32 x 3/8" RHMS through hole D (next to the pilot light), through the grill, a flat washer, the speaker frame, a #8 lockwasher and secure with an 8-32 nut.
- ( ) Insert 8-32 x 5/8" RHMS through hole E, through the grill, a flat washer, the speaker frame, a #8 lockwasher and secure with an 8-32 nut.
- ( ) Insert another 8-32 x 5/8" RHMS through hole F, through the grill, a flat washer, the speaker frame, a #8 lockwasher and secure with an 8-32 nut. Now, align the speaker with the panel, and then tighten all screws. Set this assembly aside for now.

### PHENOLIC BOARD ASSEMBLY

- ( ) Refer to Figure 6 and use 4-40 hardware as shown. Mount the four spring battery contactors and small #6 solder lugs in their proper positions on the phenolic board. Use a 4-40 x 1/4" PHMS from the topside of the board through the small #6 solder lug first, then through a spring contactor (if too snug, use a screwdriver), the phenolic board, a #4 lockwasher and secure with a 4-40 nut. (Note that two of the solder lugs lay flat and two bend up.)

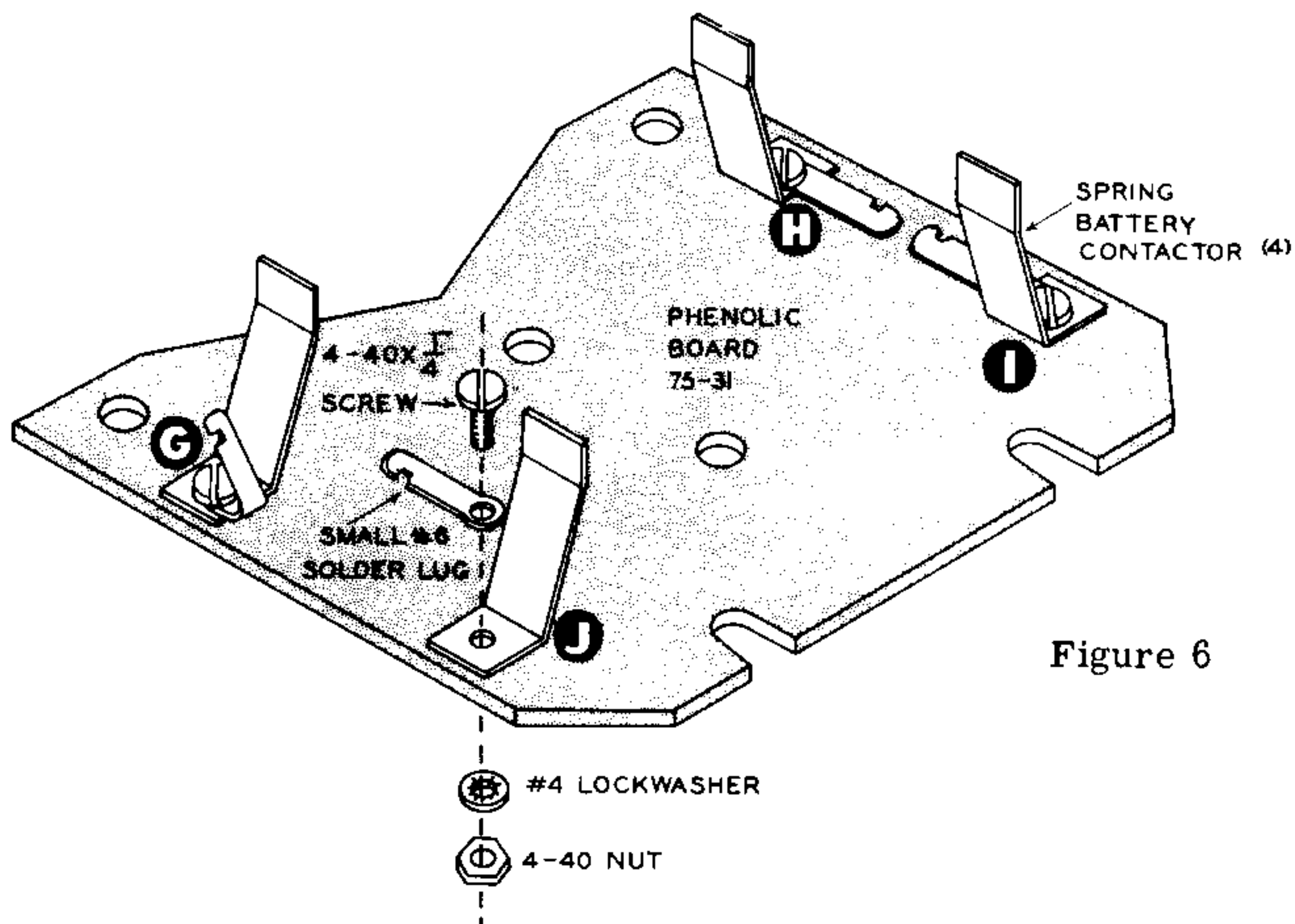

Figure 6

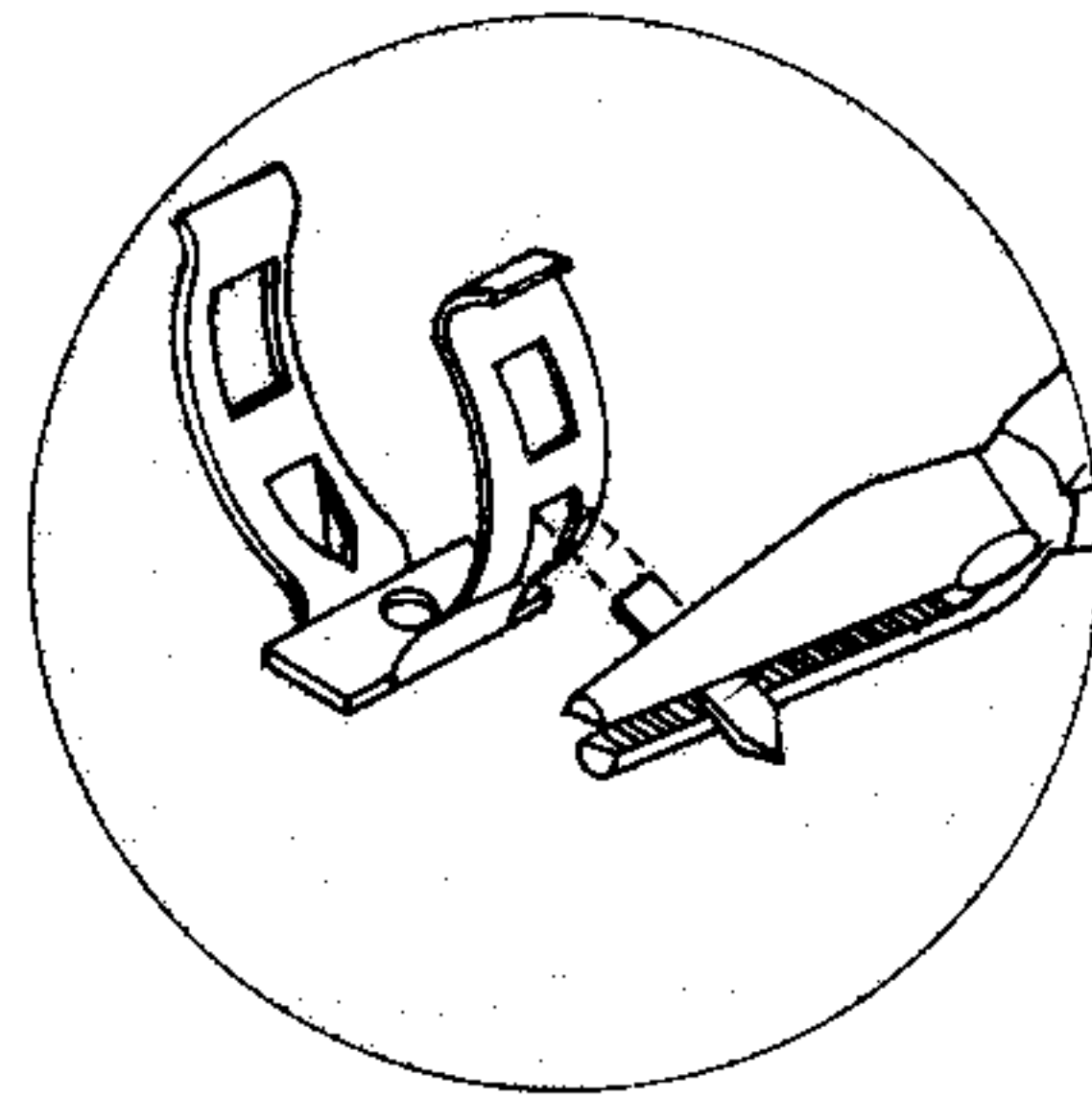
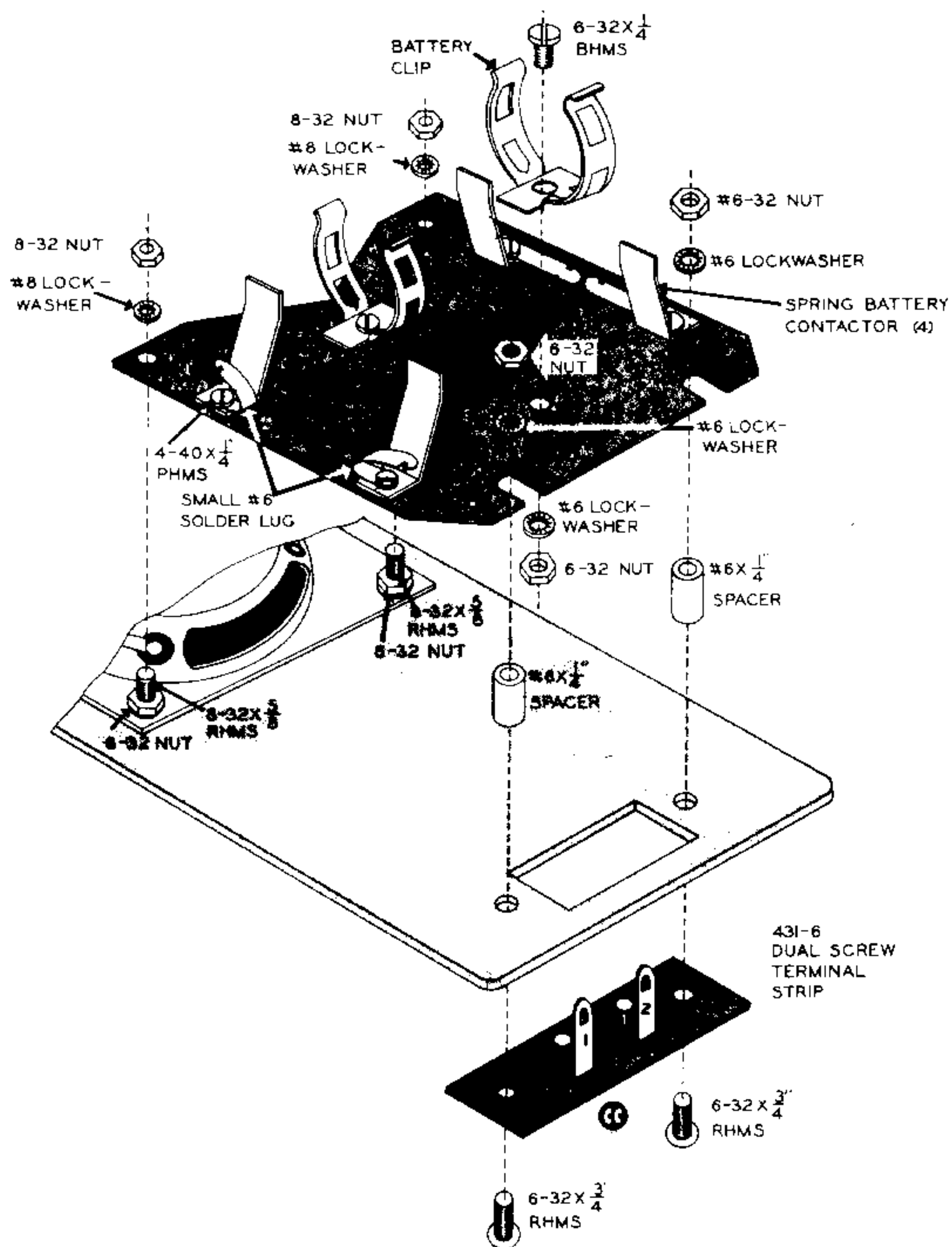

Figure 7

- ( ) Break off the two points on each battery holder clip as shown in Figure 7.
- ( ) Mount the two clips in their positions on the phenolic board as shown in Figure 7. Use a 6-32 x 1/4" BHMS through the clip, through the phenolic board, a #6 lockwasher and secure with a 6-32 nut.

### PHENOLIC BOARD-TO-PANEL ASSEMBLY

- ( ) Insert the two 6-32 x 3/4" RHMS through the dual screw terminal strip (terminal lugs face outward), then through the panel and the 1/4" spacers. While holding these screws in position, place the phenolic board assembly over the four exposed screw ends. Refer to Figure 7. Place a #6 lockwasher over each 6-32 screw and secure with 6-32 nuts. On the two 8-32 screws on the speaker, use #8 lockwashers and secure with 8-32 nuts.

### CIRCUIT WIRING

- ( ) Cut a piece of hookup wire 4 1/2" long. Trim 1/4" of the insulation off the ends. Refer to Figure 8, route the lead under the phenolic board and connect to lug 1 on terminal strip AA (NS). Connect the other lead end to lug 2 on terminal strip CC (S-1).
- ( ) Cut a piece of hookup wire 2" long. Trim 1/4" of the insulation off the ends. Connect one end to solder lug J on the phenolic board (S-1). Connect the other end to terminal 1 on the dual screw terminal strip CC (S-1). See Figure 8.
- ( ) Cut a piece of hookup wire 3 1/2" long. Trim 1/4" of the insulation off of the ends. Connect one end to the SPDT switch terminal 2 (center terminal) (S-1). Connect the other end to solder lug G on the phenolic board (S-1).

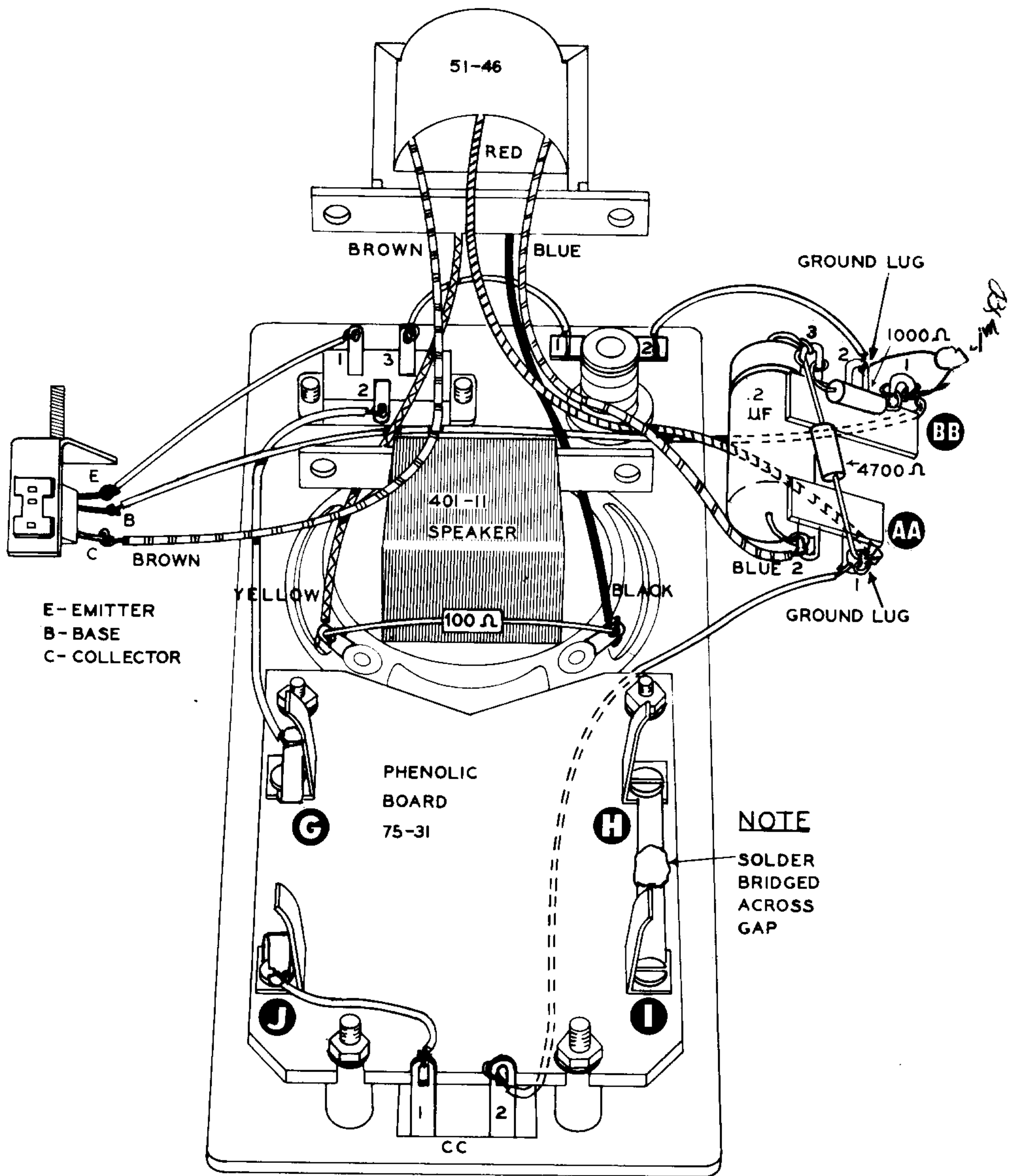

Figure 8

- ( ) Cut a piece of hookup wire 2 1/2" long. Trim the insulation 1/4". Form a small hook at one end of the lead and pinch it tight around the emitter terminal of the transistor socket (S-1). See Figure 8. Connect the other end of the lead to the SPDT switch terminal 1 (S-1).
- ( ) Form the brown lead from the transformer around the L bracket, as shown in Figure 8, and connect it to the transistor collector terminal (S-1).
- ( ) Cut a piece of hookup wire 3 3/4" long. Trim the insulation 1/4". Form a small hook at one end of the lead and pinch it tight around the base terminal of the transistor socket (S-1). Route the lead under the transformer, as shown, and connect to lug 1 on terminal strip BB (NS). Refer to Figure 8.
- ( ) Trim both leads on a 1000  $\Omega$  (brown-black-red) 1/2 watt resistor to 5/8" long. Connect one end to lug 3 on terminal strip BB (NS). Connect the other end to lug 1 on terminal strip BB (NS).
- Trim both leads of a .1  $\mu$ f disc cap to 1/2" long to lug 1 NSBB*
- ( ) Trim both leads on a 4700  $\Omega$  (yellow-violet-red) 1/2 watt resistor to 1" long. Connect one end to lug 1 on terminal strip AA (NS). Connect the other end to lug 3 on terminal strip BB (NS).
- ( ) Route the red lead, as shown in Figure 8, from the output transformer to the grounded solder lug 1 on terminal strip AA (S-3).
- ( ) Trim both leads on the .2  $\mu$ f paper capacitor to 3/4" long. Connect one lead to lug 2 on terminal strip AA (NS). (Pull the capacitor up tight to the terminal strips and bend the lead ends around the lugs.) Refer to Figure 8. Connect the other lead to lug 3 on terminal strip BB (S-3).
- ( ) Route the blue transformer lead around the end of the capacitor and connect to lug 2 on terminal strip AA (S-2).
- ( ) Cut a piece of hookup wire 1 1/4" long. Trim the insulation 1/4". Connect one end to terminal 3 on the SPDT switch (S-1). Connect the other lead end to terminal 1 on the pilot light socket (S-1).
- ( ) Cut a piece of hookup wire 1 1/4" long. Trim 1/4" of the insulation from the ends. Connect one end to lug 2 on terminal strip BB (S-2). Connect the other end to terminal 2 on the pilot light socket (S-1).
- ( ) Form a solder bridge across the two flat solder lugs H and I at the one side of the phenolic board, as shown in Figure 8. A 1/2" piece of bare wire could be used, soldered across the gap.
- ( ) Refer to Figure 9 and, noting the position of the battery caps, install the two size "C" batteries by pulling out slightly on the one spring contactor and pushing the battery against the other. Apply only sufficient pressure to allow the battery to slip into place. NOTE: If the contactors are sprung too far out to make contact with the battery, or if the batteries are installed without proper regard to polarity, your Code Oscillator will not operate!
- ( ) Be sure the 2N407 transistor leads are not bent out of line, then plug it into the socket on the L bracket.

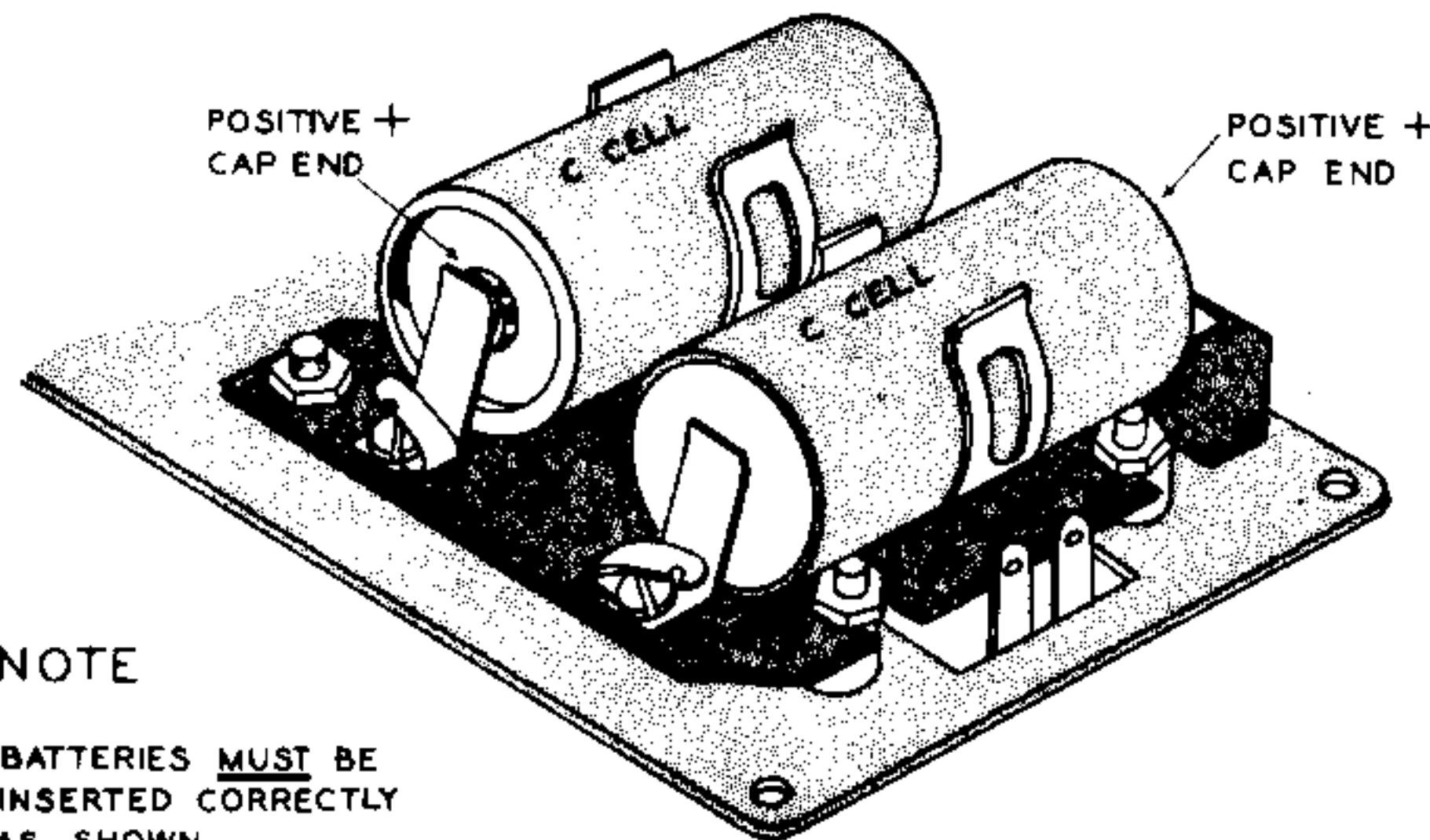

Figure 9



( ) Mount the assembled unit into its case, using the 6-32 x 2" RHMS screws at the four corners.

( ) Finally, screw the bulb into its socket.

Your Code Oscillator is now completed. Congratulations!

A Morse Code sending key needs to be connected to the two terminals marked "Key".

( ) Connect the transmitting key to the two terminals marked "Key" as shown in Figure 10.

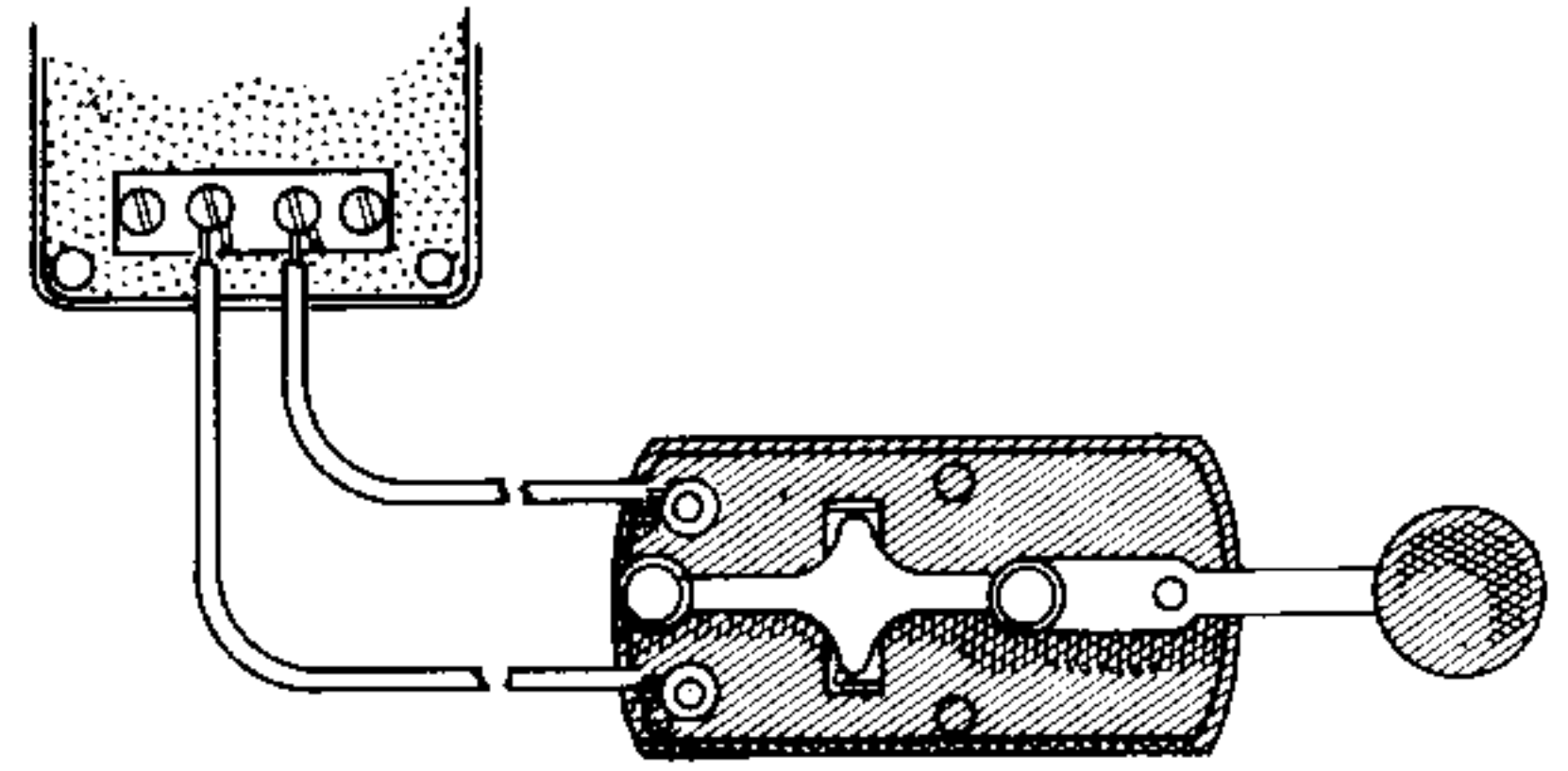

Figure 10

### KEYING TECHNIQUE

Sending on the conventional "straight" key, which requires an up and down movement of the hand and wrist, can become quite a chore after an hour or more of practicing unless a proper keying stance is used. Before any practicing is begun, a comfortable position should be chosen at the operating desk or table which will afford ample area for the key and the entire forearm and elbow. See Figure 11.

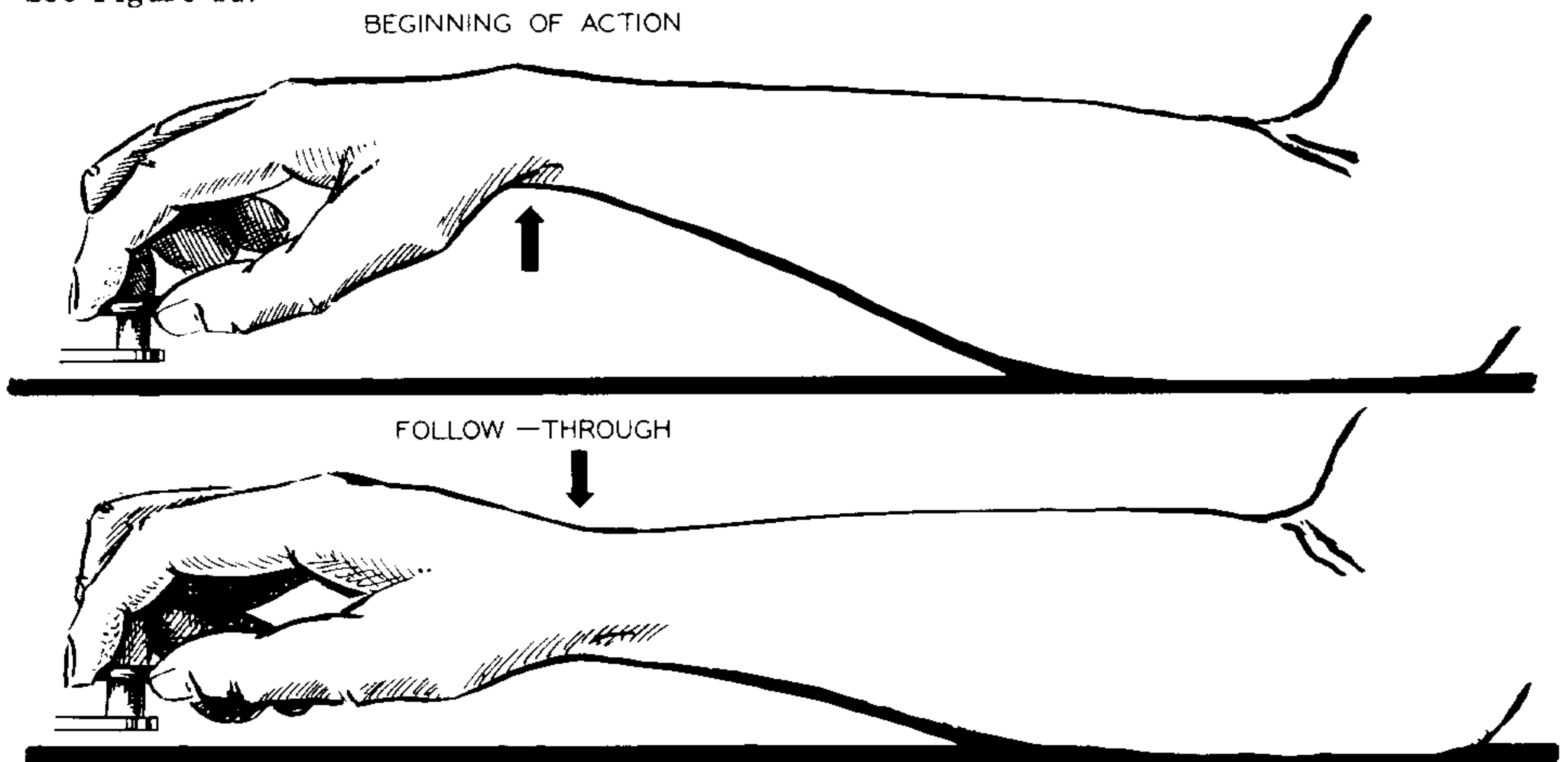
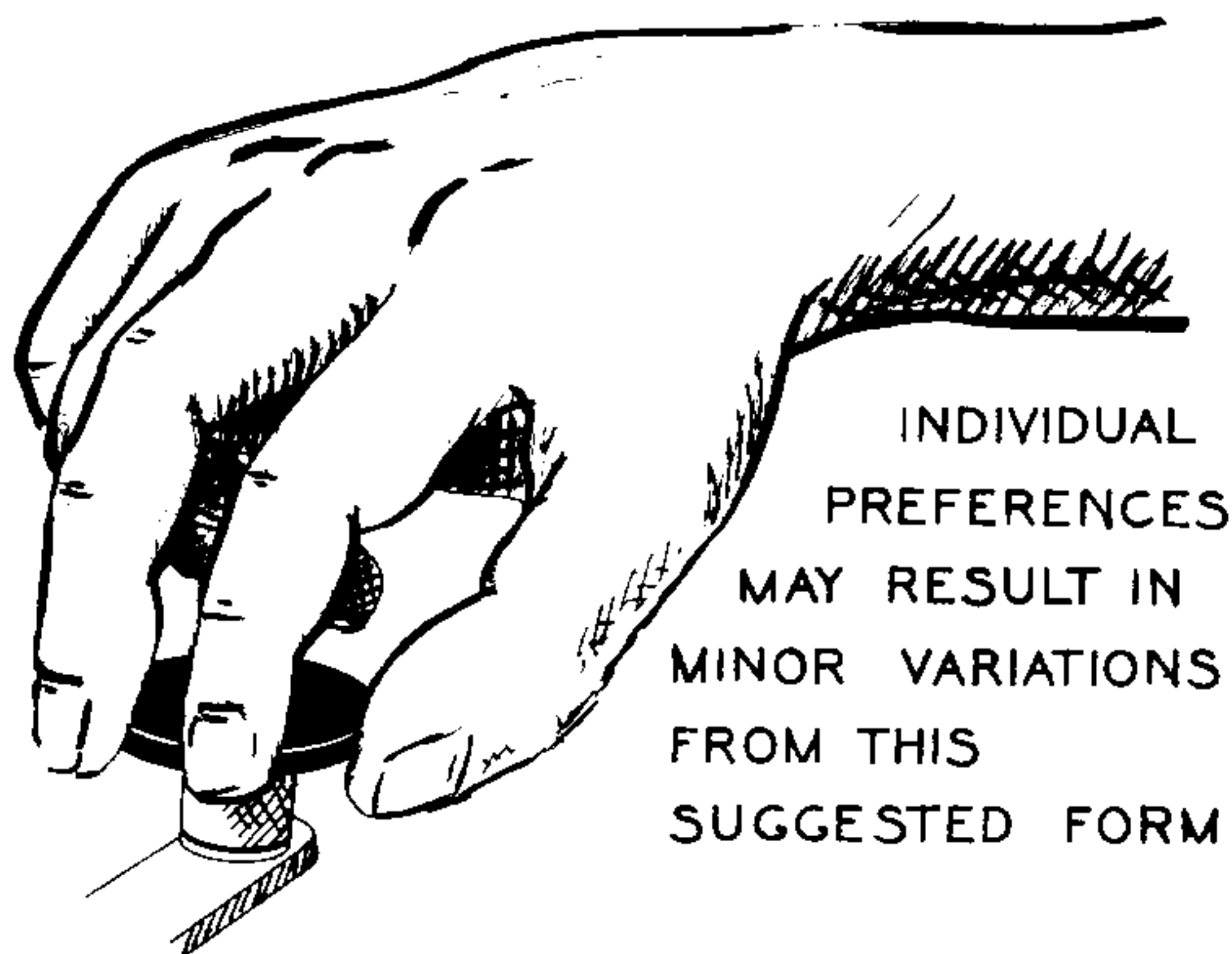

Figure 11

Unless the key is mounted on a weighted base, it will be necessary to screw it down to a thin board or, if permissible, to the operating surface. This is to prevent the key from "walking" around while operating it.

A firm, comfortable hold of the key knob is necessary. See Figure 12 on Page 14. Avoid a cramped hand position. The entire hand should form an arch with the fingers resting lightly on the key knob, as shown. Before sending, the wrist should be held up in a slight continuation of the arch formed by the hand. See Figure 13 on Page 14.

Figure 12



INDIVIDUAL  
PREFERENCES  
MAY RESULT IN  
MINOR VARIATIONS  
FROM THIS  
SUGGESTED FORM

The action of sending is accomplished by throwing the wrist downward, with the hand transferring this energy to the key. Opposition to this movement is afforded by the spring tension adjustment on the key. See Figure 13. Adjust this spring tension until sending feels free and relatively effortless.

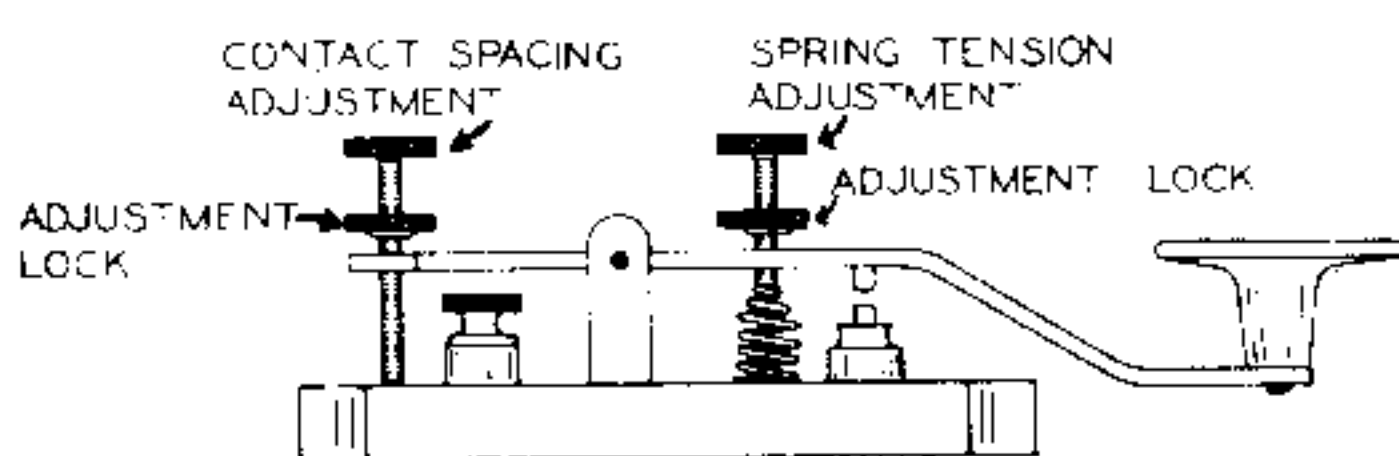
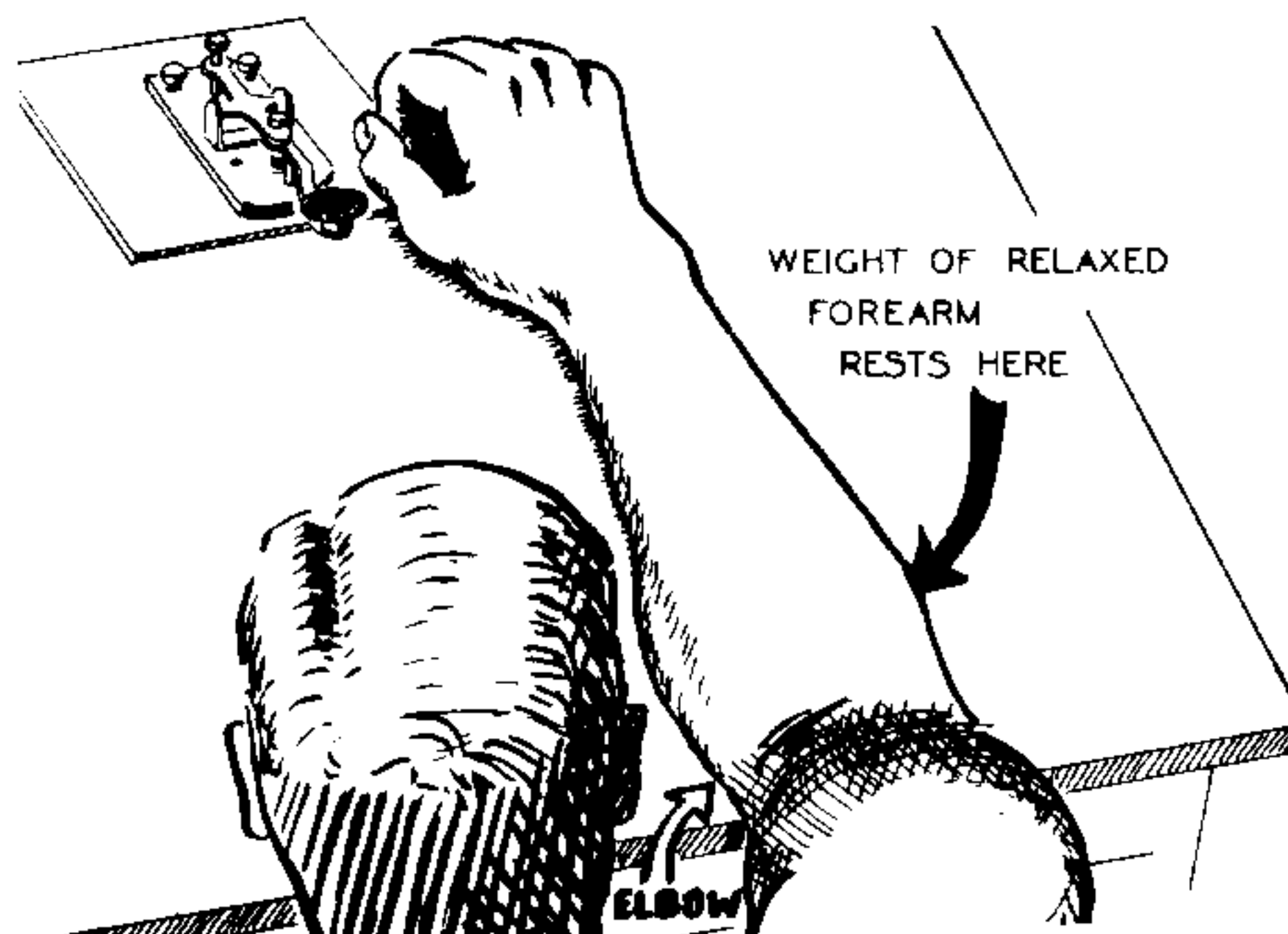

Figure 13A

Figure 13



Contact spacing should be adjusted to approximately the thickness of a business card or near twelve-thousandths of an inch.

### LEARNING THE MORSE CODE

The Morse Code has long been a reliable means of communication or means of conveying information. Speaking, reading, writing, typewriting, shorthand, semaphore and sign language are but a few of the many ways of conveying information. While each of these methods present a problem in learning, there are some who believe the Morse Code to be less difficult to master than most.

An individual would first of all require sufficient desire and determination to stick with it until the code is mastered.

A deciding factor could well be the prospect of enjoying all the privileges of communications afforded to the many thousands of holders of Amateur Radio licenses.

The Morse Code should be thought of as a language of sound and never as a particular combination of dots and dashes. The code equivalents may be spoken of as "dit" and "dah" with the letter A being "didah" (the "T" being dropped in such combinations). The "di" sound should be staccato. The number "5" sent as a code character should sound like a machine gun burst: "didididit". Each "dah" should be stressed equally, with one being no longer or shorter than the other.

Only a few characters should be taken at one time, to be learned thoroughly in didah language, before taking on a new group. Sometimes an experienced friend can be enlisted to "send" to you by means of your CO-1 or by just sounding the characters in "dit" and "dah" language. The Morse Code may be learned by listening to it and writing it down or calling it out. Increasing speed should be no consideration at this time, although it may be preferable to send the letters fast with long spaces in between to allow more time for the mental transition to take place. Then, to gain speed, the sender need only decrease the time space between each character sent.

Any characters that seem to be especially difficult should be given special concentration with repetition until they no longer remain a problem.

#### THE CONTINENTAL (INTERNATIONAL) MORSE CODE

A	● —	didah	N	— ●	dahdit
B	— ● ● ●	dahdididit	O	— — —	dahdahdah
C	— ● — ●	dahdidahdit	P	● — — ●	didahdahdit
D	— ● ●	dahdidit	Q	— — ● —	dahdahdidah
E	●	dit	R	● — ●	didahdit
F	● ● — ●	dididahdit	S	● ● ●	dididit
G	— — ●	dahdahdit	T	—	dah
H	● ● ● ●	didididit	U	● ● —	dididah
I	● ●	didit	V	● ● ● —	didididah
J	● — — —	didahdahdah	W	● — —	didahdah
K	— ● —	dahdidah	X	— ● ● —	dahdididah
L	● — ● ●	didahdidit	Y	— ● — —	dahdidahdah
M	— —	dahdah	Z	— — ● ●	dahdahdidit

1	● ■ ■ ■ ■	didahdahdah	6	■ ● ● ● ●	dahdididit
2	● ● ■ ■ ■	dididahdah	7	■ ■ ● ● ●	dahdahdidit
3	● ● ● ■ ■	didididah	8	■ ■ ■ ● ●	dahdahdidit
4	● ● ● ● ■	didididah	9	■ ■ ■ ■ ●	dahdahdahdit
5	● ● ● ● ●	didididit	0	■ ■ ■ ■ ■	dahdahdahdah

Period	● ■ ● ■ ● ■	didahdididah
Comma	■ ■ ● ● ■ ■	dahdahdididah
Question Mark	● ● ■ ■ ● ●	dididahdidit
Error	● ● ● ● ● ● ● ●	didididididit
Double Dash	■ ● ● ● ■	dahdididah
Wait	● ■ ● ● ●	didahdidit
End of Message	● ■ ● ■ ●	didahdahdit
Invitation to Transmit	■ ● ■	dahdidah
End of Work	● ● ● ■ ● ■	didididah
Fraction Bar	■ ● ● ■ ●	dahdididahdit

### MAINTENANCE

There should be no real maintenance problems. A definite dimming out of the light, or little or no tone, will indicate weak batteries. These are standard "C" cells and are readily available at many stores.

Sufficient spring tension should be maintained against the battery ends by bending the contactors toward each other before inserting the batteries.

No trouble should be anticipated from the <sup>407</sup>2N228 transistor.

If the bulb is burned out or broken, a proper replacement would be marked #14 or 2.5 volts at .3 ampere. Any 2 cell (screw base) flashlight bulb should work as well.

The contacts on the key should be kept clean to ensure clean-cut keying. Use a strip of fine grade sandpaper (or emery cloth). Open the space between the key contacts about 1/16", insert the sandpaper and depress the key with just slight pressure. Draw the sandpaper through the contacts, turn it over, and repeat the process to clean both contacts. Reset the key to proper contact spacing.

**CAUTION:** Dead batteries should be removed immediately and disposed of, as they quite often leak an acid which will damage some of the components in your kit.





PART No.	PARTS Per Kit	DESCRIPTION
----------	---------------	-------------

Hardware (Cont'd.)

250-92	2	8-32 x 5/8" round head machine screw
252-2	4	4-40 nut
252-3	6	6-32 nut
252-4	6	8-32 nut
253-8	4	#10 flat washer (brass)
254-1	9	#6 lockwasher
254-2	6	#8 lockwasher
254-9	4	#4 lockwasher
255-13	2	#6 x 1/4" spacer
258-6	4	Spring battery contactor
259-6	4	#6 small solder lug

8-32 x 5/8" RHMS



#8 LOCKWASHER

252-2	4	4-40 nut
252-3	6	6-32 nut
252-4	6	8-32 nut
253-8	4	#10 flat washer (brass)



8-32 NUT



6-32 NUT



4-40 NUT

254-1	9	#6 lockwasher
254-2	6	#8 lockwasher
254-9	4	#4 lockwasher



#8 LOCKWASHER



#6 LOCKWASHER

255-13	2	#6 x 1/4" spacer
258-6	4	Spring battery contactor
259-6	4	#6 small solder lug

SMALL #6 SOLDER LUG

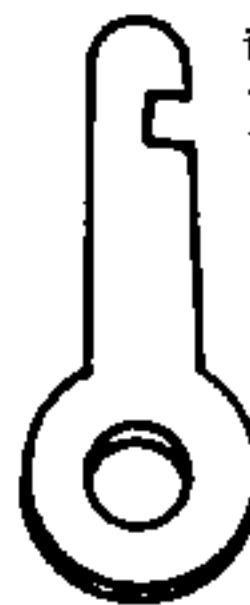

#6 x 1/4" SPACER

Miscellaneous

73-3	1	7/16" x 1/2" rubber grommet
75-31	1	Phenolic board
209-17	1	Speaker grille
344-1	1	Length hookup wire
401-11	1	Speaker (2 1/2")
412-6	1	#14 pilot bulb (screw base)
417-28	1	<del>2N238</del> transistor 2N407
434-47	1	Pilot light socket (screw base)
435-7	1	Transistor socket mounting clip
408-M3	1	Case (black bakelite)
1441-2	1	Transmitting key
331-6	1	Solder
595-259	1	Manual

7/16" x 1/2" RUBBER GROMMET

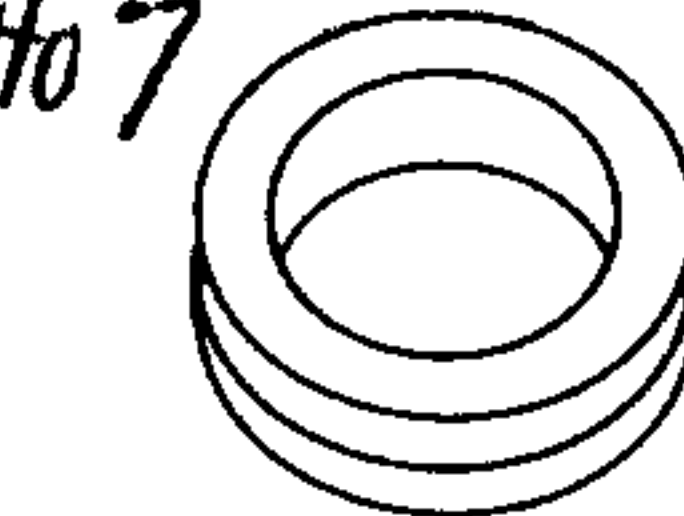

#10 FLAT WASHER

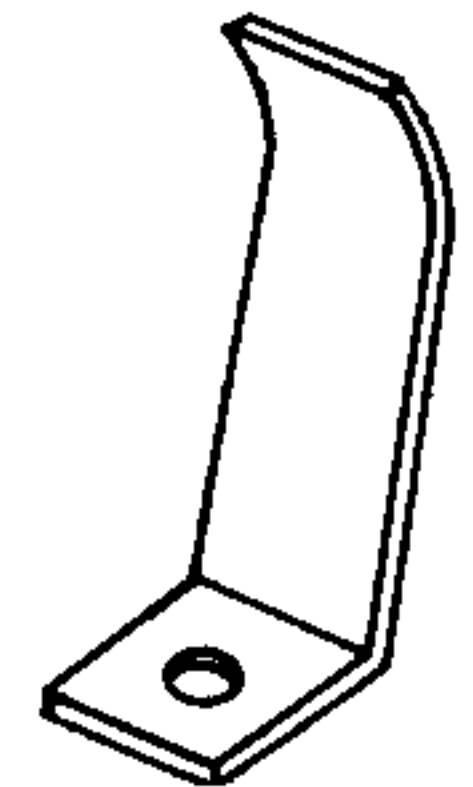

SPRING BATTERY CONTACTOR

417-28	1	<del>2N238</del> transistor 2N407
434-47	1	Pilot light socket (screw base)

435-7	1	Transistor socket mounting clip
-------	---	---------------------------------

408-M3	1	Case (black bakelite)
1441-2	1	Transmitting key
331-6	1	Solder
595-259	1	Manual



2N238 TRANSISTOR

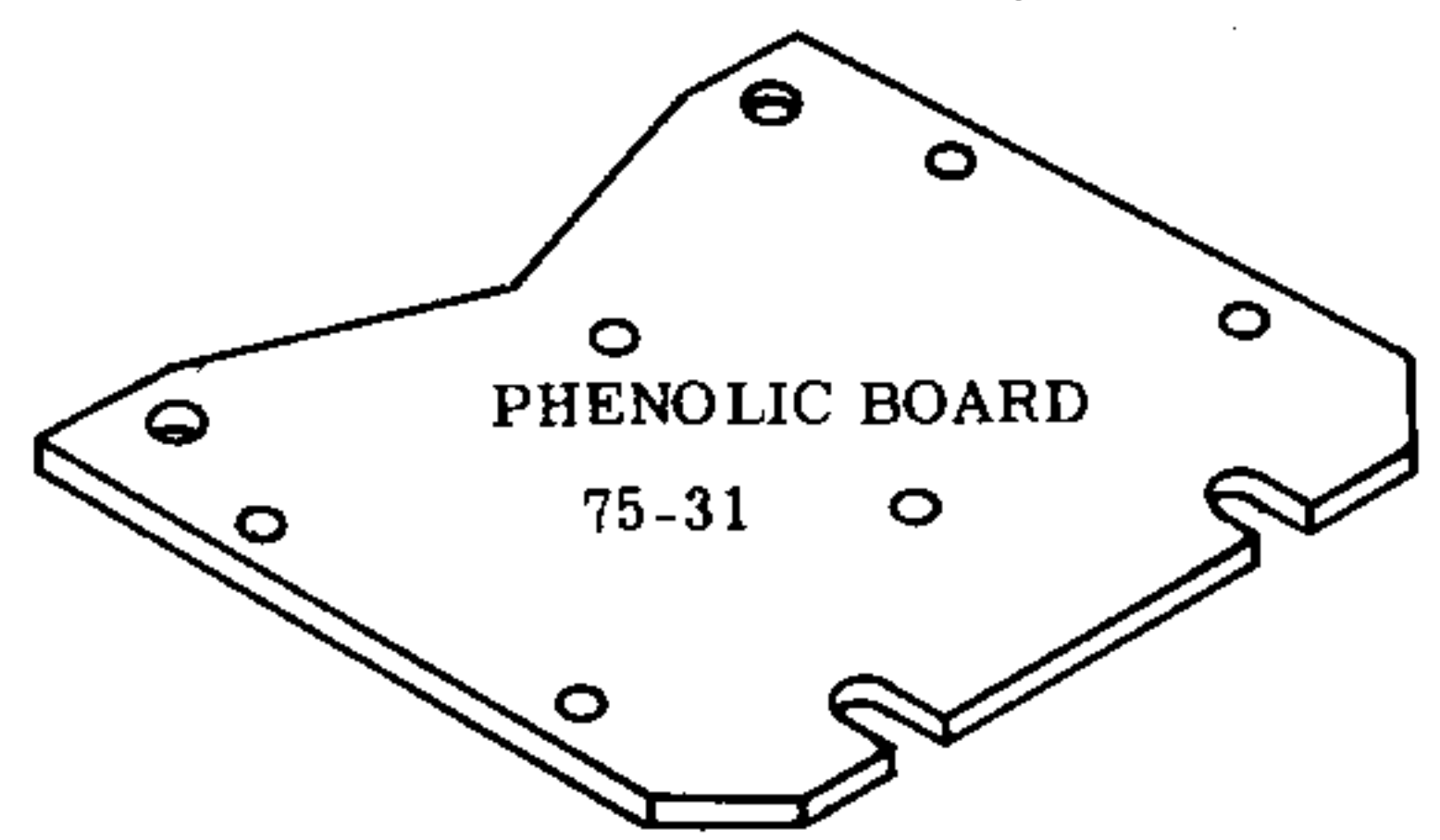

PHENOLIC BOARD

75-31

Two standard size "C" flashlight batteries should be purchased at this time for use in the completed kit.



TRANSISTOR SOCKET MOUNTING CLIP

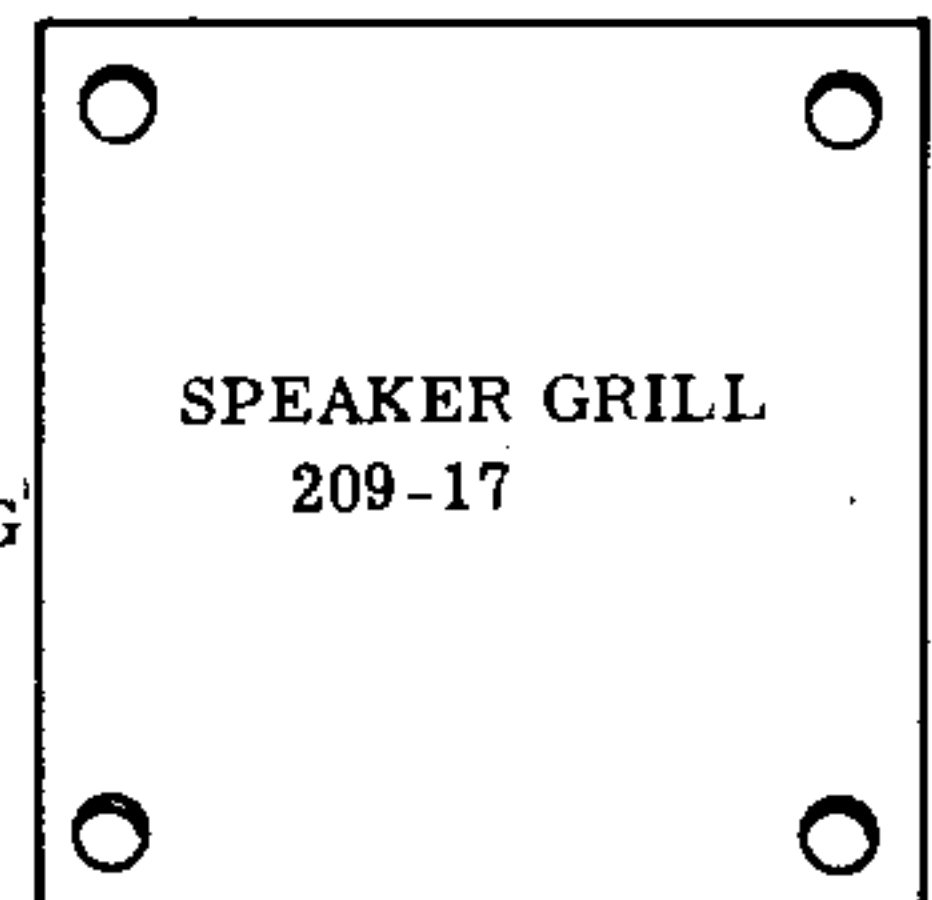

SPEAKER GRILL

209-17

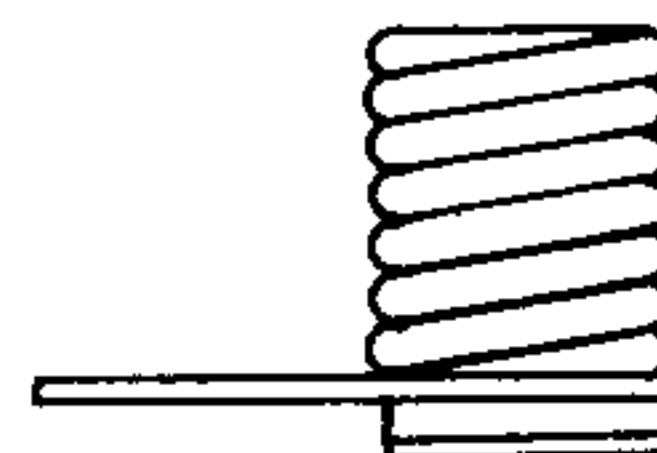

PILOT LIGHT SOCKET

434-47

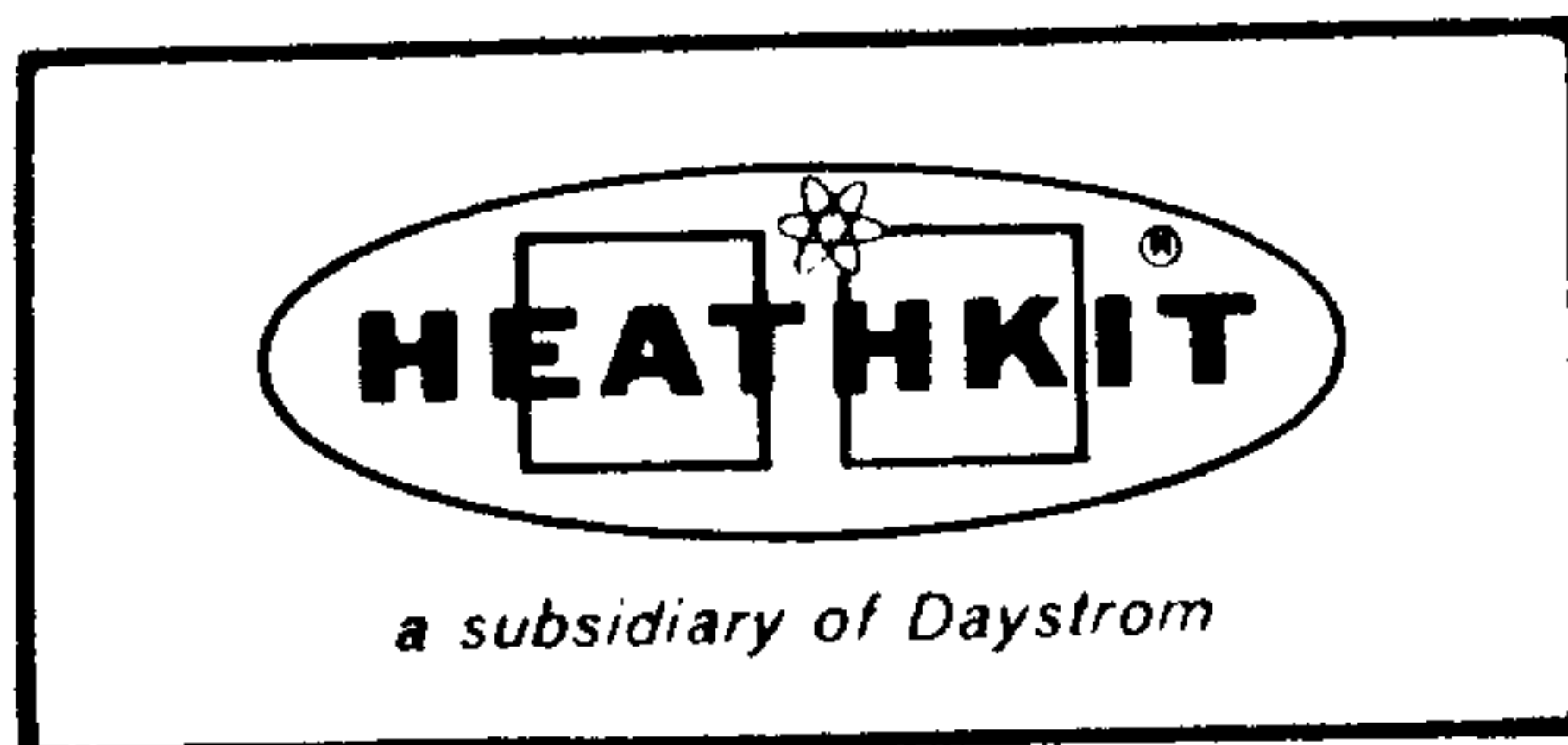

# HEATH COMPANY

BENTON HARBOR, MICHIGAN  
YUKON 3-3961 TWX-616-983-3897

February 5, 1964

Dear Customer:

A new type of transistor and a disc capacitor are being supplied with your Model CO-1 Code Oscillator kit to improve circuit operation. To incorporate these new parts in your kit, please make the following changes in the CO-1 Manual before beginning assembly.

Page 3 - On the Schematic Diagram, change the 2N238 transistor number to read "2N407."

Also, draw in a capacitor (C2, .1 $\mu$ fd) from the "B" transistor lug to the line that connects from the KEY to R2 and ground ( $\frac{1}{\text{---}}$ ).

Page 11 - Mark Figure 8 to indicate a .1  $\mu$ fd disc capacitor connected between lugs 1 and 2 of terminal strip BB.

Page 12 - In the fourth step, change the last soldering instruction from (S-2) to (NS).

In the tenth step, change the first soldering instruction from (S-1) to (S-2).

In the last step, change the transistor number from 2N238 to "2N407."

Add the following step just after the fourth step:

- ( ) Trim both leads of a .1  $\mu$ fd disc capacitor to 1/2" long. Connect one lead to lug 1 (S-3) and the other lead to lug 2 (NS) of terminal strip BB.

Page 16 - In the third paragraph, change the transistor number from 2N238 to "2N407."

Page 19 - Add the following item to the "Capacitor" section,

Add:        21-81        1        .1  $\mu$ fd disc capacitor

(over)

Page 20 - Make the following change in the "Miscellaneous" section,

Change:	417-5	1	2N238 transistor
To:	<u>417-28</u>	1	<u>2N407</u> transistor

Also, the new 2N407 transistor is round, not oblong like the 2N238 transistor shown on Page 20.

Thank you,

HEATH COMPANY

CO-1  
2-5-64