

PRICE \$1.00



Assembling
and Using Your...

Heathkit

CA-1

**CONELRAD
ALARM**

MODEL CA-1

HEATH COMPANY

A Subsidiary of Daystrom Inc.

BENTON HARBOR, MICHIGAN

ASSEMBLY AND OPERATION OF THE HEATHKIT CONELRAD ALARM MODEL CA-1

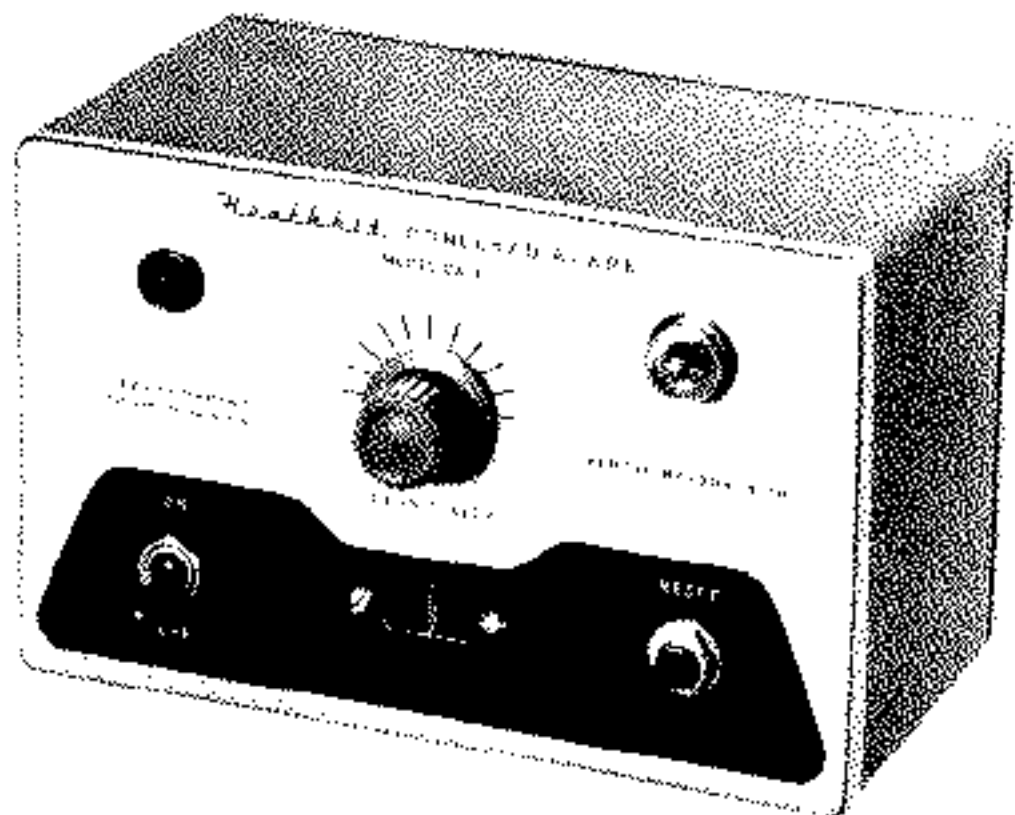

SPECIFICATIONS

Tube Complement:	2D31 thyratron.
AVC Sensitivity:	-2 volts to -20 volts
Operating Power:	115 volts AC, 60 cycles 7 watts.
Power Capability:	115 volts AC, 60 cycles 700 watts.
Cabinet Size:	7 3/8" wide x 4 11/16" high x 4 1/8" deep.
Net Weight:	3 lbs.
Shipping Weight:	4 lbs.

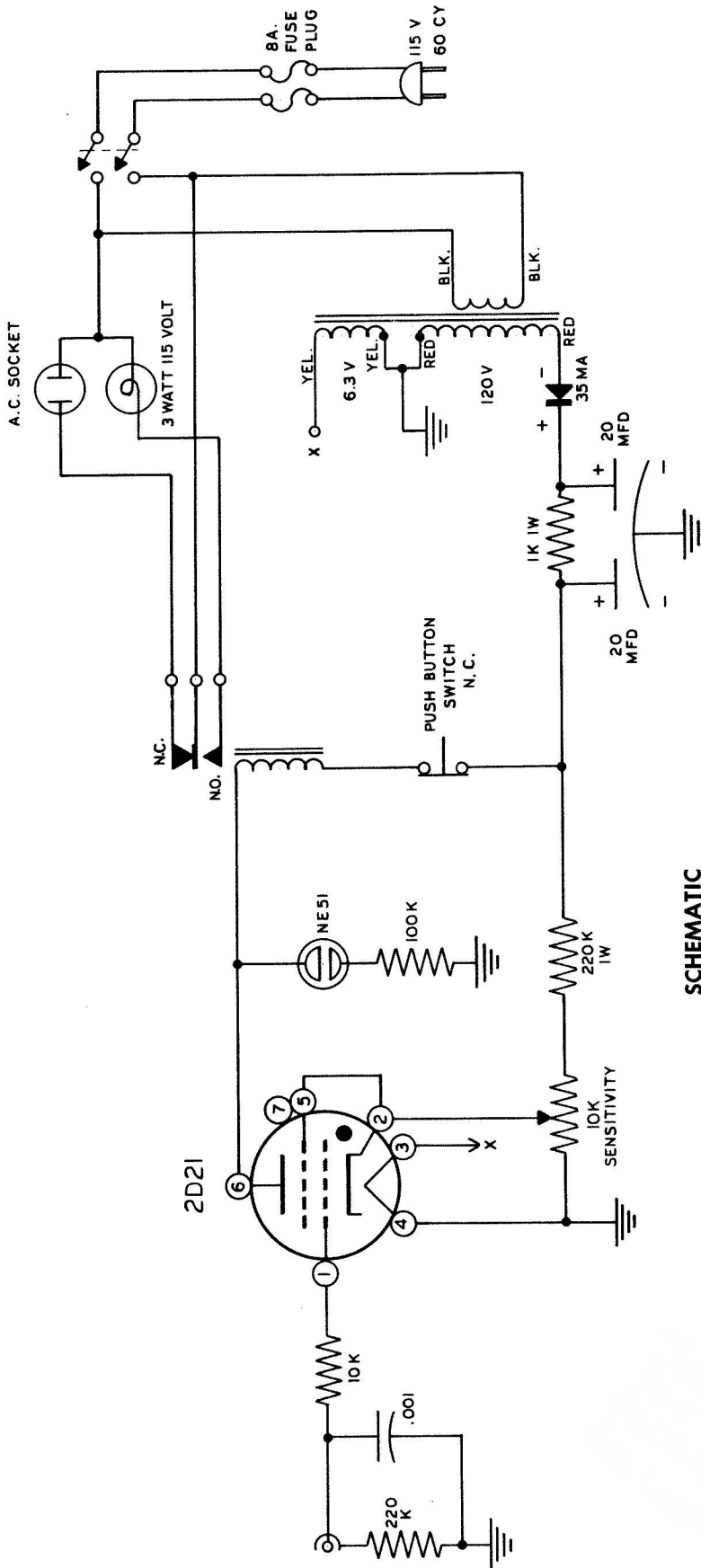

SCHEMATIC
HEATHKIT CONELRAD ALARM
MODEL CA-1

INTRODUCTION

The Heathkit Conelrad Alarm, model CA-1, is used in conjunction with a broadcast receiver to provide automatic alarm control for your transmitter.

As of January 2, 1957 the government requires that any operator of a radio transmitter must have some means of determining when a Conelrad alert is in progress and to leave the air at this time. At the time of an alert, broadcast stations will interrupt their carrier twice, transmit a 1000 cycle tone for fifteen seconds, give the alert message and then either close down or change frequency to 640 or 1240 KC. The simplest means of obeying the Conelrad regulation is to continuously monitor a Conelrad key broadcast station. However, it is normally human to forget to monitor a broadcast station while transmitting, or to overlook the fact that the monitored station has left the air.

When properly connected, the CA-1 will not permit transmitter operation unless a station is being monitored for an alert. It also will shut down the transmitter in the event of an alert. This precludes the possibility of your station being the recipient of a guided missile which is using the antenna for a homing device.

CIRCUIT DESCRIPTION

The CA-1 uses a 2D21 thyratron as a control tube. This is a gas filled tetrode type tube in which the grid normally exercises control as in ordinary vacuum tubes. However, once the grid loses control it cannot regain this function until the plate voltage drops below the firing point of the gas. In this application the tube acts as a switch which is tripped electrically and must be reset manually. The grid is controlled by a negative AVC (automatic volume control) bias from a broadcast receiver. This keeps the tube cut off until the broadcast carrier wave is interrupted. When the carrier wave is interrupted by a Conelrad alert the tube fires and stays in this state. A relay in the plate circuit is actuated by the current through the tube and removes the AC power from the transmitter. At the same time another contact on the relay lights a red warning light. At the end of an alert when the broadcast station returns to the air, the CA-1 may be reset by depressing the push button on the panel. This removes the plate voltage momentarily and allows the grid to regain control.

A sensitivity control on the panel permits the CA-1 to be adjusted for different AVC levels, which might be encountered in various receivers. The unit is self powered from the AC line and in turn supplies AC power to the transmitter. It has its own power supply consisting of a transformer to supply the 2D21 filament voltage and to obtain isolation from the AC line, a selenium rectifier and a resistance-capacitance filter. A neon light on the panel indicates the presence of DC voltage and is used as a safety check to prove the unit is in operating condition. The CA-1 may be used on AC-DC receivers without danger of electrical shocks. This is possible because of a 220 K Ω isolating resistor which effectively separates the CA-1 chassis from the AC-DC receiver.

NOTES ON ASSEMBLY AND WIRING

The assembly and wiring of the CA-1 is quite simple and very little difficulty should be experienced in construction. Read the notes on soldering and wiring on the inside rear cover. Crimp all leads tightly to the terminal before soldering. Be sure both the lead and terminal are free of wax, corrosion or other foreign substances. Use only the best rosin core solder, preferably a type containing the new activated fluxes such as Kester "Resin-Five," Ersin "Multicore" or similar types.

Unless otherwise indicated, all wire used is insulated. Wherever there is a possibility of the bare leads on resistors and capacitors shorting to other parts or to chassis, the leads should be covered with insulated sleeving. This is indicated in the instructions by the phrase "use sleeving." Bare wire is used where the lead lengths are short and the possibility of short circuits are non-existent.

Leads on resistors, capacitors and transformers are generally much longer than they need to be to make the indicated connections. In these cases, the excess leads should be cut off before the part is added to the chassis. In general, the leads should be just long enough to reach their terminating points. Not only does this make the wiring much neater but in many instances, the excessively long leads will actually interfere with proper operation of the instrument.

The pictorials indicate actual chassis wiring and designate values of the component parts. We very strongly urge that the chassis layout, lead placement and grounding connections be followed exactly as shown. While the arrangement shown is probably not the only satisfactory layout, it is the result of considerable experimentation and trial. If followed carefully, it will result in a stable instrument operating at a high degree of accuracy and dependability.

Space has been provided for you to check off each operation as it is completed. This is particularly important in wiring and it may prevent omissions or errors, especially where your work is interrupted frequently as the wiring progresses. Some kit builders have also found it helpful to mark each lead in colored pencil on the pictorial as it is added.

The abbreviation (NS) indicates that the connection should not be soldered as yet, for other wires will be added. When the last wire is installed, the terminal should be soldered and the abbreviation (S) is used to indicate this.

Soldering in this kit, as in all radio equipment, is extremely important. If you are inexperienced in this art pay particular attention to the soldering instructions which follow this section of the manual.

PROPER SOLDERING PROCEDURE

Only a small percentage of Heathkit purchasers find it necessary to return an instrument for factory service. Of these, by far the largest proportion function improperly due to poor or improper soldering.

Correct soldering technique is extremely important. Good solder joints are essential if the performance engineered into the kit is to be fully realized. If you are a beginner with no experience in soldering, a half-hour's practice with odd lengths of wire and a tube socket will be a worthwhile investment.

High quality solder of the proper grade is most important. There are several different brands of solder on the market, each clearly marked "Rosin Core Radio Solder." Such solders consist of an alloy of tin and lead, usually in the proportion of 50:50. Minor variations exist in the mixture such as 40:60, 45:55, etc. with the first figure indicating the tin content. Radio solders are formed with one or more tubular holes through the center. These holes are filled with a rosin compound which acts as a flux or cleaning agent during the soldering operation.

NO SEPARATE FLUX OR PASTE OF ANY KIND SHOULD BE USED. We specifically caution against the use of so-called "non-corrosive" pastes. Such compounds, although not corrosive at room temperatures, will form residues when heated. The residue is deposited on surrounding surfaces and attracts moisture. The resulting compound is not only corrosive but actually destroys the insulation value of non-conductors. Dust and dirt will tend to accumulate on these "bridges" and eventually will create erratic or degraded performance of the instrument.

NOTE: ALL GUARANTEES ARE VOIDED AND WE WILL NOT REPAIR OR SERVICE INSTRUMENTS IN WHICH ACID CORE SOLDER OR PASTE FLUXES HAVE BEEN USED. WHEN IN DOUBT ABOUT SOLDER, IT IS RECOMMENDED THAT A NEW ROLL PLAINLY MARKED "ROSIN CORE RADIO SOLDER" BE PURCHASED.

If terminals are bright and clean and wires free of wax, frayed insulation and other foreign substances, no difficulty will be experienced in soldering. Crimp or otherwise secure the wire (or wires) to the terminal, so a good joint is made without relying on solder for physical strength. To make a good solder joint, the clean tip of the soldering iron should be placed against the joint to be soldered so that the terminal is heated sufficiently to melt solder. The solder is then placed against both the terminal and the tip of the iron and will immediately flow out over the joint. Refer to the sketch on the following page. Use only enough solder to cover wires at the junction; it is not necessary to fill the entire hole in the terminal with solder. Excess solder may flow into tube socket contacts, ruining the socket, or it may creep into switch contacts and destroy their spring action. Position the work so that gravity tends to keep the solder where you want it.

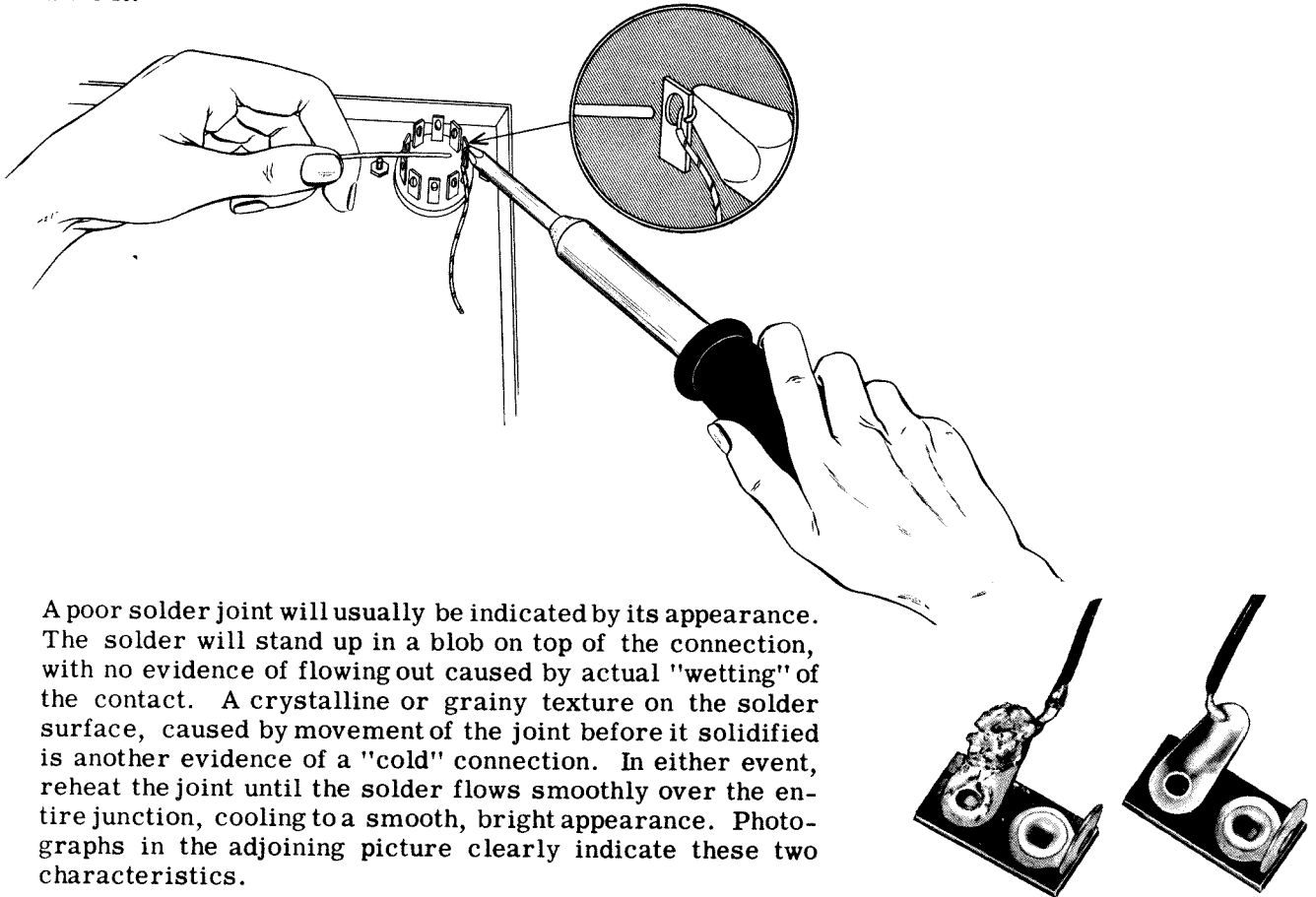

A poor solder joint will usually be indicated by its appearance. The solder will stand up in a blob on top of the connection, with no evidence of flowing out caused by actual "wetting" of the contact. A crystalline or grainy texture on the solder surface, caused by movement of the joint before it solidified is another evidence of a "cold" connection. In either event, reheat the joint until the solder flows smoothly over the entire junction, cooling to a smooth, bright appearance. Photographs in the adjoining picture clearly indicate these two characteristics.

A good, clean, well-tinned soldering iron is also important to obtain consistently perfect connections. For most wiring, a 60 or 100 watt iron, or the equivalent in a soldering gun, is very satisfactory. Smaller irons generally will not heat the connections enough to flow the solder smoothly over the joint and are recommended only for light work, such as on etched circuit boards, etc. Keep the iron tip clean and bright. A pad of steel wool may be used to wipe the tip occasionally during use.

Take these precautions and use reasonable care during assembly of the kit. This will insure the wonderful satisfaction of having the instrument operate perfectly the first time it is turned on.

Resistors and controls generally have a tolerance of $\pm 10\%$ unless otherwise stated in the parts list. Therefore, a 100 K Ω resistor may test anywhere between 90 K Ω and 110 K Ω . (The letter K is commonly used to designate a multiplier of 1000.) Tolerances on capacitors are generally even greater. Limits of +100% -50% are common for electrolytic capacitors. The components furnished with your Heathkit have been specified to enable you to obtain maximum performance, accuracy and life from the completed instrument.

ASSEMBLY AND WIRING

- () Examine Figure 1 closely and insert two 5/16" rubber grommets and three 3/8" rubber grommets where shown.
- () Take the #6 small solder lug and bend at a right angle about 1/8" from the center of the hole.
- () Using the 3-48 screws, nuts and #3 lockwashers, with the #6 small solder lug, mount the 7-pin miniature socket, positioning the tube pins and the #6 small solder lug as shown in Figure 1.

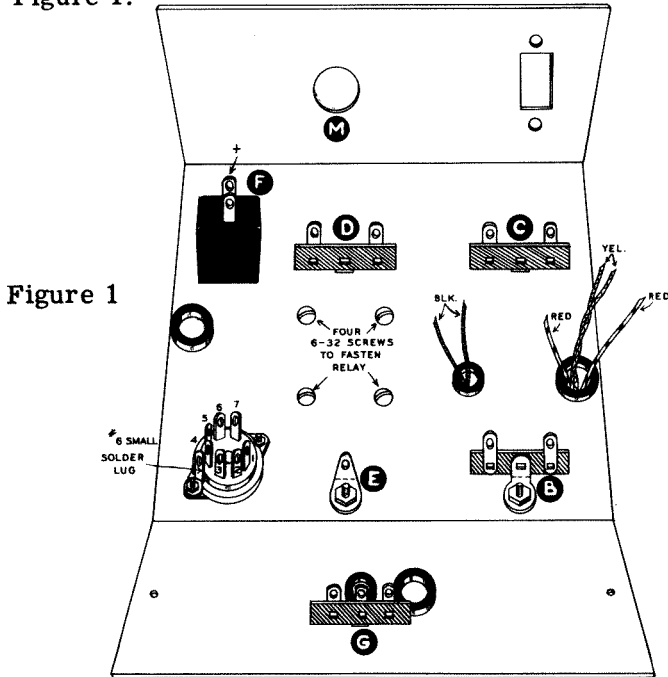

Figure 1

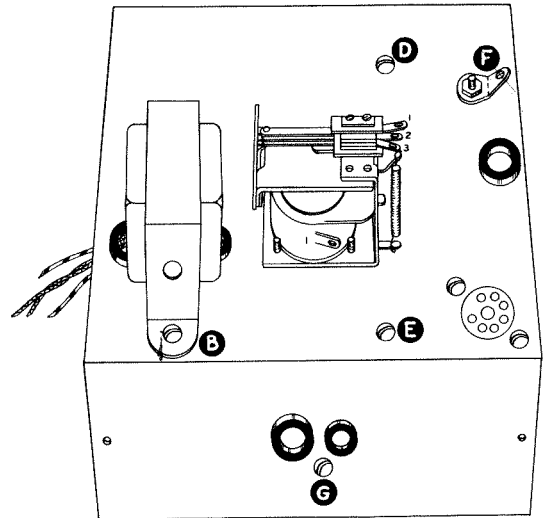

Figure 2

- () Referring to Figure 1, mount a #6 solder lug at hole (E) using a 6-32 x 1/4" screw. Position as shown and secure with a 6-32 nut.
- () Mount a 2-lug terminal strip at hole (D) using a 6-32 x 1/4" screw. Position as shown and secure with a 6-32 nut and a #6 lockwasher under the nut.
- () Mount the selenium rectifier in hole (F). Position the rectifier so that the side marked plus will appear as shown in Figure 1. On the other side of the chassis place a #6 solder lug over the stud and secure with a 6-32 nut. Position the lug as shown in Figure 2.
- () Mount the 3-lug terminal strip at hole (G) with a 6-32 x 1/4" screw and nut, using a #6 lockwasher under the mounting foot of the terminal strip and a #6 lockwasher under the nut. See Figure 1.
- () Next mount the power transformer. Insert the two red and two yellow leads of the transformer through the 3/8" rubber grommet and pass the two black leads through the 5/16" rubber grommet. See Figure 2.
- () Using the 6-32 x 1/4" transformer mounting screws, secure the two 2-lug terminal strips on the underside of the chassis. Position as shown in Figure 1, and secure the transformer and the two terminal strips with 6-32 nuts and #6 lockwashers.
- () Mount the relay so that the solder lugs on the contact leaves are facing away from the transformer. Refer to Figure 2. Place a #6 lockwasher over each of four 6-32 x 1/4" screws. Note that the relay has four tapped holes in the bottom. Fasten the relay by inserting the screws through the chassis from the underside. See Figure 1.

PANEL ASSEMBLY

1. Remove the first nut from the DPST switch. Insert the switch through hole H with the lockwasher between the second nut and the panel and replace the first nut on the front of the panel. See Figure 3. Adjust the rear nut so that the switch bushing and the front nut are flush. Position the switch so that the OFF position is down on the panel. (A slot on the switch bushing indicates OFF position.) Tighten the nut.
2. Screw a 3/8" nut and place a 3/8" lockwasher on the push button switch. Insert the switch through hole (J) and place a 3/8" flat washer and a 3/8" nut on the front. Adjust in the same manner as with the DPST switch. Position the switch as shown in Figure 3 and tighten.

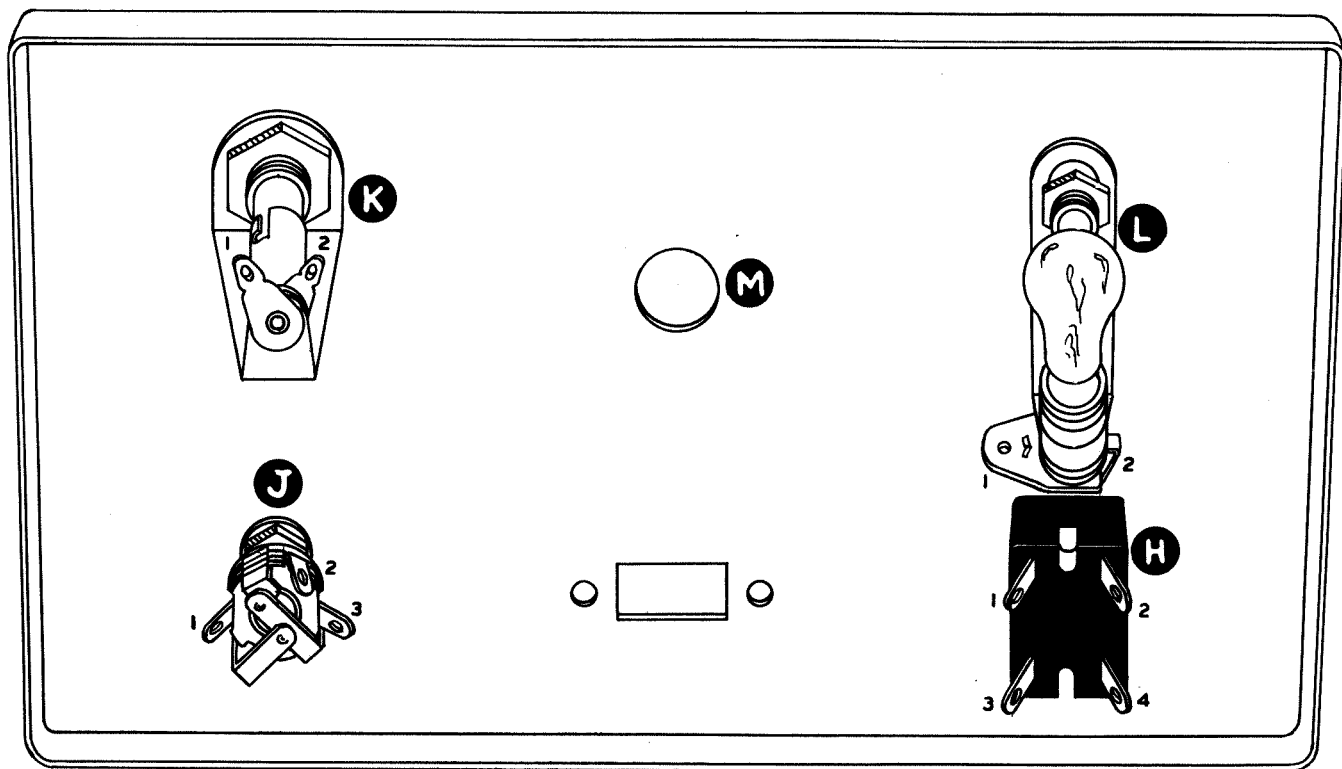
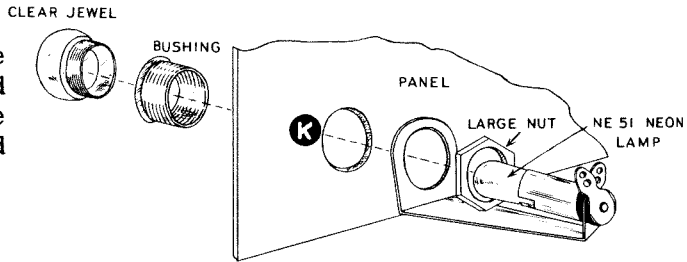

Figure 3

(N) Mount the clear pilot light assembly at hole (K). See Detail 1 and position as shown in Figure 3, and tighten.

(N) Mount the red pilot light assembly at hole (L). Insert the 3 watt 120 volt lamp and move the bracket up and down so that the filaments in the lamp line up with the red jewel. Remove the lamp and tighten the nut.



Detail 1

MOUNTING THE CHASSIS TO THE PANEL

(N) Take the control solder lug, bend and form as shown in Detail 2 and cut off 3/8". Place the solder lug on the control and insert the control through hole (M) of the chassis and then through the front panel. Place a 3/8" flat washer and a 3/8" nut on the front. See Figures 4 and 5. Do not tighten. Line the control solder lug up with terminal #1 (S).

(N) Mount the AC receptacle in the rectangular hole using the two 6-32 x 3/8" screws. Secure the receptacle with 6-32 nuts with #6 lockwashers under the nuts. Tighten the 3/8" control nut. See Figure 5.

(N) Dress one of the yellow leads from the transformer along the edge of the chassis to pin 3 of the tube socket (S). Refer to Pictorial 1.

(N) Take the other yellow lead and one of the red leads and cut to a length of 4 1/2". Strip off 5/16" of insulation and dress along with the other yellow lead and connect to solder lug E (NS).

(N) Dress the other red lead along the two terminal strips and connect to the unmarked terminal of the selenium rectifier (S). See Pictorial 1.

(N) Cut one of the black leads to a length of 2 3/4" and strip 5/16" of insulation from the end. Connect to CC1 (NS).

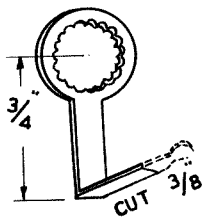

Detail 2

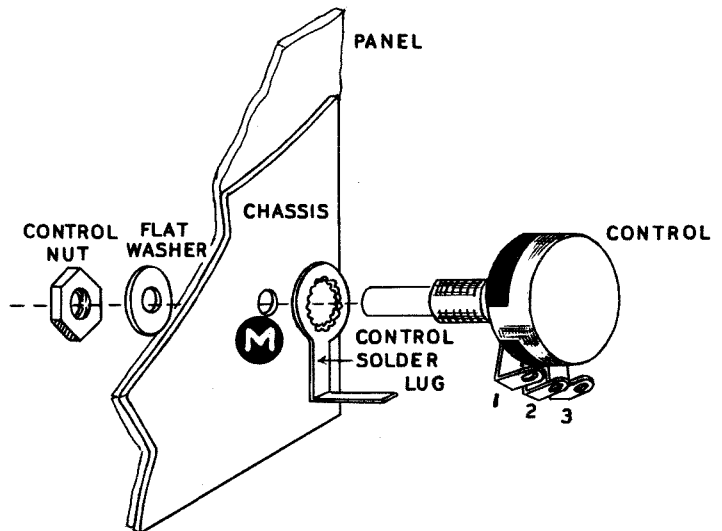

Figure 4

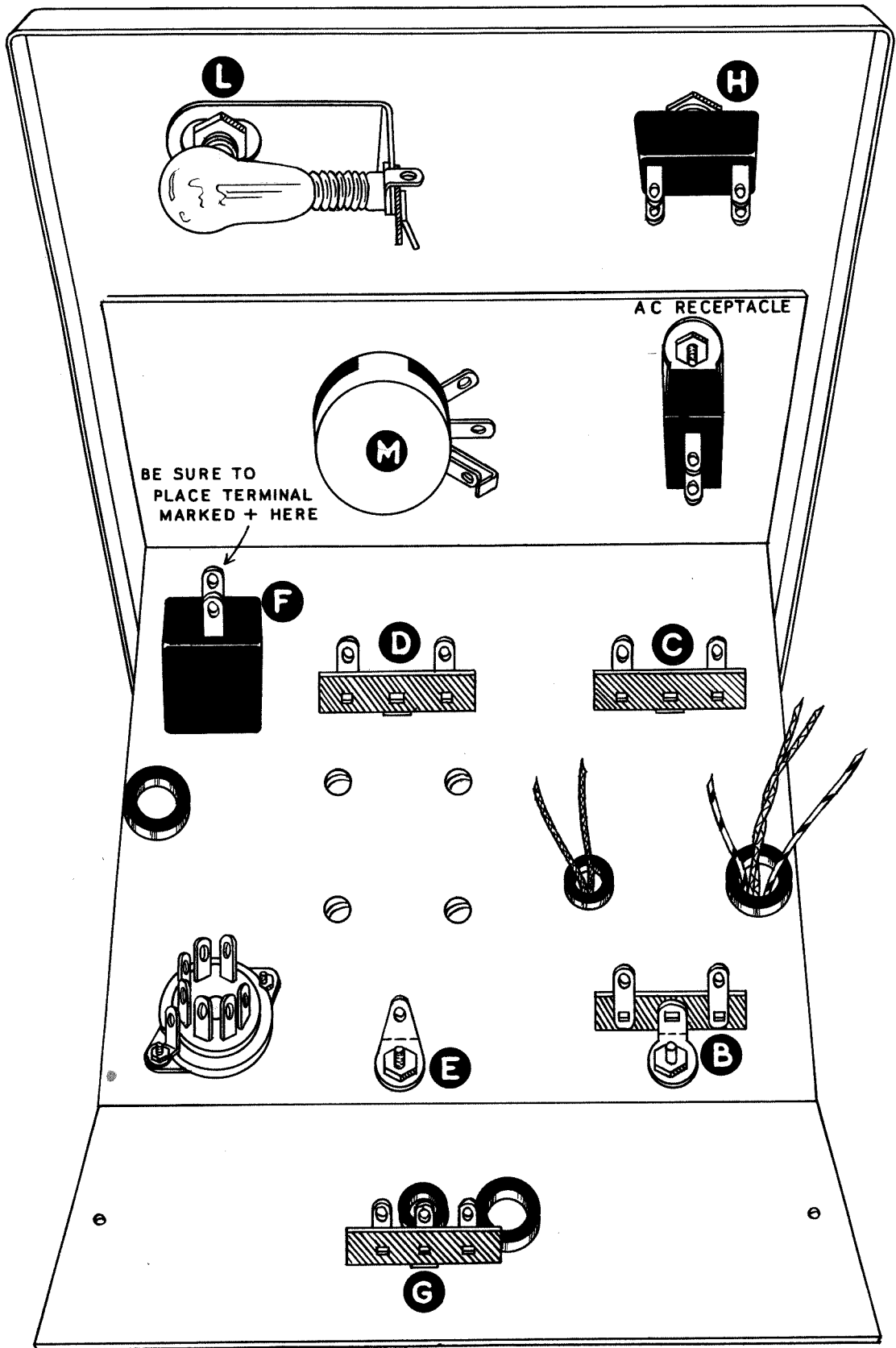
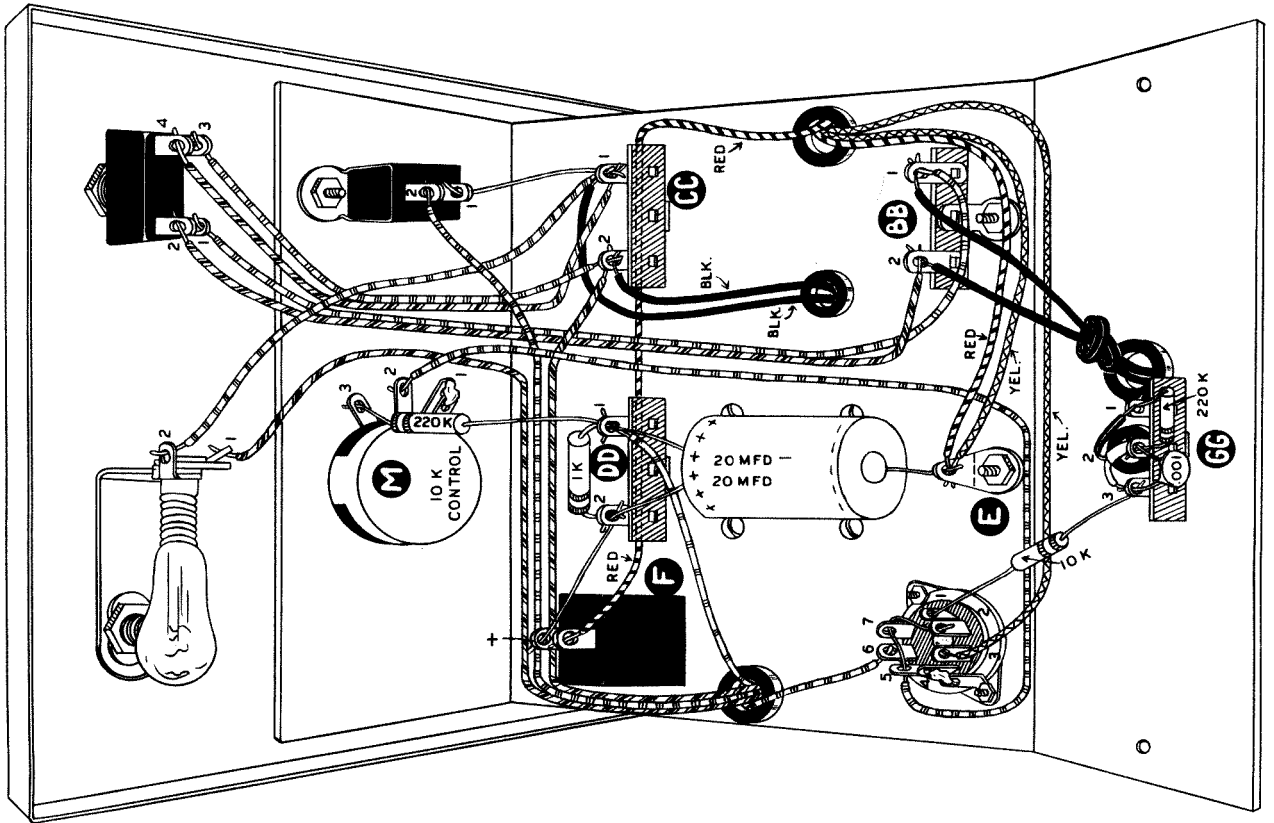
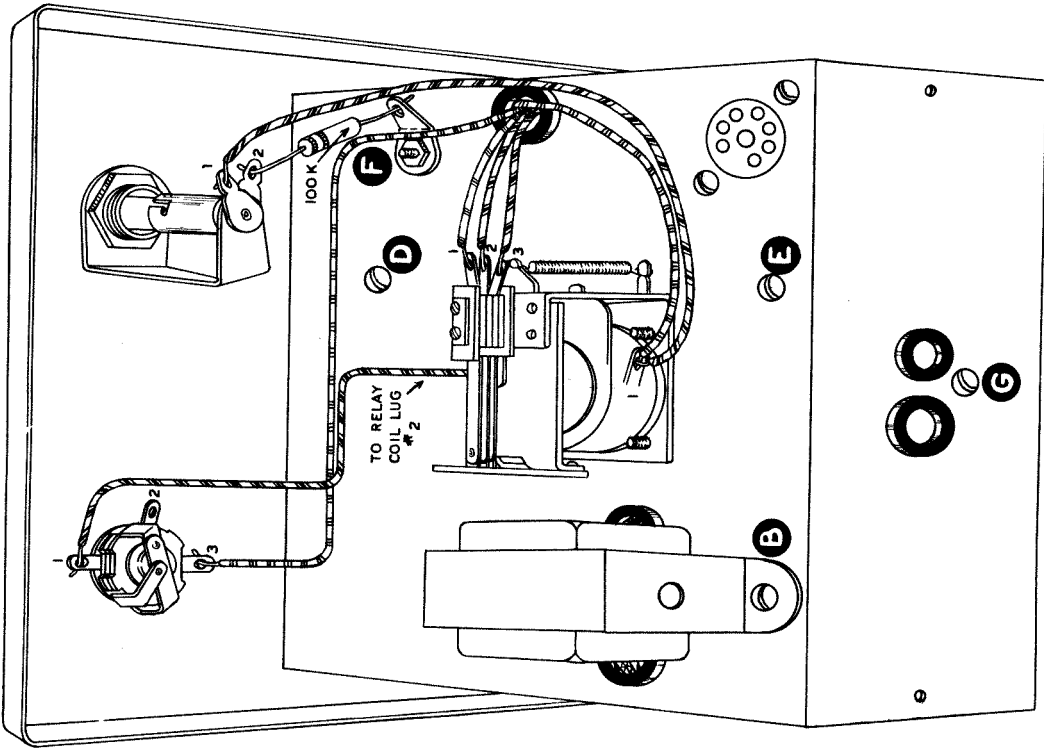

Figure 5



PICTORIAL 1



PICTORIAL 2

- 2 Cut the other black lead to a length of 1 3/4" and strip 5/16" of insulation from the end. Connect to CC2 (NS).
- 2 Cut a wire to a length of 8 3/4" and strip 5/16" of insulation from both ends. Connect one end to terminal #1 of the DPST switch (S). Connect the other end to BB1 (NS). Dress the following leads as shown in Pictorial 1.
- 2 Cut a wire to a length of 8 3/4" and strip 5/16" of insulation from both ends. Connect one end to terminal #2 of the DPST switch (S). Connect the other end to BB2 (NS).
- 2 Cut a wire to a length of 6 1/2" and strip 5/16" of insulation from both ends. Connect one end to terminal #3 of the DPST switch (S). Connect the other end to CC2 (NS).
- 2 Cut a wire 8" in length and strip 5/16" from one end and 3/4" from the other end. Connect the 5/16" stripped end to terminal #4 of the DPST switch (S). Feed the other end through CC1 (NS) and then connect to terminal #1 of the AC receptacle (S).
- 2 Cut a wire 6 1/2" in length and strip 5/16" from both ends. Connect one end to terminal #2 of the red pilot light assembly (S). Connect the other end to CC1 (S).
- 2 Cut a wire 6 1/4" in length and strip 5/16" from both ends. Connect one end to CC2 (S). Dress this lead as shown and up through the 3/8" rubber grommet to relay contact #2 (S). See Pictorial 2.
- 2 Cut a wire 7 1/2" in length and strip 5/16" from both ends. Connect one end to terminal #2 of the AC receptacle (S). Dress the other end up through the 3/8" rubber grommet to relay contact #1 (S).
- 2 Cut a wire 8 3/4" in length and strip 5/16" from both ends. Connect one end to terminal #1 of the red pilot light assembly (S). Dress the other end through the 3/8" rubber grommet to relay contact #3 (S).
- 2 Cut a wire 7 1/4" in length and strip 5/16" from one end and 1" from the other end. Feed the 7/8" end through pin 5, through pin 7 and connect to pin 2 of the tube socket. Solder these three connections. Connect the other end to terminal #2 of the control (S). Dress the lead as shown.
- 2 Cut a wire 8 1/2" in length and strip 5/16" from both ends. Connect one end to terminal #3 of the push button switch (S). Dress the lead through the 3/8" rubber grommet and connect to DD1 (NS). See Pictorials 1 and 2.
- 2 Cut a wire 3 3/4" in length and strip 5/16" from both ends. Connect one end to pin #6 of the tube socket (S). Feed the other end through the 3/8" rubber grommet to terminal #1 of the relay coil (NS).
- 2 Cut a wire 5 1/2" in length and strip 5/16" from both ends. Connect one end to terminal #1 of the push button switch (S). Connect the other end to terminal #2 of the relay coil (S). Terminal #2 of the push button switch is not used.
- 2 Cut a wire 4" in length and strip 5/16" from both ends. Connect one end to terminal #1 of the relay coil (S). Connect the other end to terminal #1 of the clear pilot light assembly (S).
- 2 Cut both leads of a 100 K Ω 1/2 watt resistor (brown-black-yellow) to 3/8". Connect one lead to terminal #2 of the clear pilot light assembly (S) and the other lead to the #6 ground lug (S). See Pictorial 2.
- 2 Cut one lead of a 220 K Ω 1 watt resistor (red-red-yellow) to 5/8" and the other lead to 3/8". Connect the 5/8" end to terminal #3 of control M (S) and the other end to DD1 (NS).

- (N) Cut the common negative lead of the electrolytic condenser to 5/8". Cut one of the positive leads to 5/8" and the other to 1 1/2". The positive leads are designated by a series of + marks on one end of the case. Connect the common negative lead to the #6 ground lug (S). Feed the 1 1/2" lead through DD2 (NS) and then connect to the + terminal of the selenium rectifier (S). Connect the 3/8" lead to DD1 (NS).
- (N) Cut both leads of a 1 K Ω 1 watt resistor (brown-black-red) to 5/8". Bend the leads at right angles. Connect one lead to DD1 (S) and the other lead to DD2 (S).
- (N) Cut both leads of a 10 K Ω 1/2 watt resistor (brown-black-orange) to 5/8". Connect one lead to pin 1 of the tube socket (S) and the other end to GG3 (NS).
- (N) Move pin 4 of the tube socket over against the #6 small solder lug (S).
- (N) Cut both leads of a 220 K Ω 1/2 watt resistor (red-red-yellow) to 1/2" and bend at right angles. Connect one lead to GG1 (NS) and the other lead to GG2 (NS).
- (N) Cut both leads of a .001 μ fd 600 volt disc ceramic capacitor to 1/2". Connect one lead to GG2 (S) and the other lead to GG3 (NS).
- (N) Insert the shielded cable through the 5/16" rubber grommet on the rear apron of the chassis. Strip a 3/4" length of outer insulation from the shielded cable. Unwind the braid and twist to form a lead. Slip a 3/4" length of sleeving over this lead. Strip the inner conductor 5/16" and connect the inner conductor to GG3 (S), then connect the braid to GG1 (S).
- (N) Insert the line cord through the 3/8" rubber grommet on the rear apron of the chassis and tie a knot about 1 1/2" from the end for strain relief. Separate the leads and strip 5/16" of insulation from both ends. Connect one lead to BB1 (S) and the other lead to BB2 (S).
- (N) Pass the line cord and the shielded cable through the large hole in the back of the cabinet.
- (N) Connect the fused plug to the line cord as follows: Open the plug to expose the screw terminals. Tie a knot approximately 1" back from the end of the cord and separate the leads back to the knot. Strip the end of the leads back 1/2" and tin the bare strands lightly. Position the knot in the "bell" of the plug, run the leads along the separate channels provided and connect the wires to the screw terminals with a hook in the same direction as the screw rotation. Reassemble the plug and insert the two fuses.
- (N) Strip 3/4" of outer insulation from the shielded cable, unwind the braid and twist. Strip 1/2" of insulation from the inner conductor and tin.
- (N) Install the 2D21 tube, the NE51 neon lamp and the 117 volt 3 watt lamp in their respective sockets.
- (N) Install the four rubber feet on the cabinet and slide the Conelrad Alarm into the cabinet. Secure by installing two sheet metal screws through the rear of the cabinet into the rear apron of the chassis. Install the knob on the sensitivity control.

CONNECTION TO THE RECEIVER

Selection of a good sensitive receiver is very important, particularly for those that live in fringe areas from Conelrad key broadcast stations. A list of Conelrad key broadcast stations and their operating schedules are at the back of this manual. This list may change from the time of printing so it is important that a check be made for your particular locality. A good check would be to monitor aurally several stations to ascertain their relative signal strength and operating schedule.

- () On the following page there are step-by step instructions for connecting the CA-1 Conelrad Alarm to the Heathkit AR-3 and BR-2 receivers.

CONNECTIONS FOR THE HEATHKIT AR-3 RECEIVERS

- () Remove the chassis from the cabinet and locate the A. N. L. switch and accessory socket on the rear apron of the chassis. Mount the phono socket between these two. Refer to Figure 6.
- () Cut both leads of the 10 megohm resistor (brown-black-blue) to $3/4$ ".
- () Refer to Page 11, Pictorial 3 in the AR-3 manual. Connect one lead of the 10 megohm resistor to CC4 (S).

If the AR-3 manual is not available locate the 5-lug terminal strip and connect one lead of the 10 megohm resistor to the junction of the 3.3 megohm (orange-orange-green), the 47 K Ω (yellow-blue-orange), the 100 μ fd disc ceramic capacitor and a yellow lead with a spiral shield around it on the A. V. C. line (S).

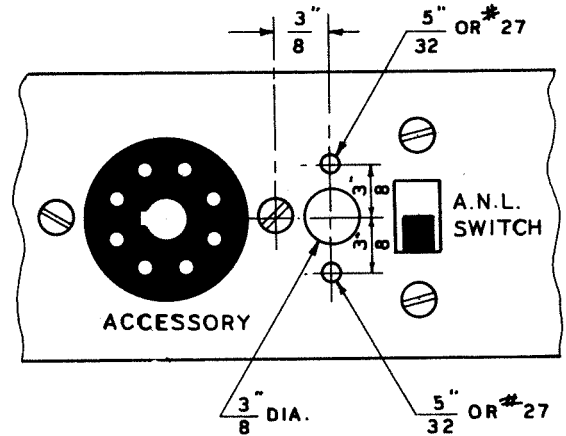

Figure 6

AR-3 CHASSIS

- () Connect the other lead to the center conductor of the phono socket (S).

When these connections are completed, continue with the first step on Page 15.

CONNECTIONS FOR THE HEATHKIT BR-2 RECEIVERS

- () Remove the chassis from the cabinet and locate the 3-lug terminal strip.
- () Refer to Page 11, Pictorial 3 in the BR-2 manual. Connect one lead of the 10 megohm resistor to N1 (S) and the other lead to D3 (NS).
- () If the phono socket on the receiver is not being used, remove the short length of wire going from the phono socket terminal #2 to the slide switch J terminal #1.
- () Cut a length of wire to 6" and strip 5/16" insulation from both ends.
- () Connect one end to D3 (S) and the other end to terminal #2 of the phono socket (S).
- () If the phono socket on the receiver is being used mount the phono socket supplied with the kit on the rear apron of the chassis directly in line with tube socket D. Refer to Figure 7 for hole sizes.

If the BR-2 manual is not available, connect one lead of the 10 megohm resistor to the junction of the 3.3 megohm resistor (orange-orange-green), the .05 μ fd condenser, and two wires in the 3-lug terminal strip. Then refer to the preceding steps on this page.

When these connections are completed, continue with the first step on Page 15.

- () The first step in connecting the CA-1 to the receiver is to locate the second detector and AVC circuit. Remove the receiver from the cabinet and examine the tubes used. The second detector can be identified by the type tube used. Most receivers have a tube layout chart located somewhere on the cabinet or chassis. Some may have the tube type stamped on the chassis near its respective socket, or the tube type may be read from the tube itself. On the following page is a partial list of diode second detectors most commonly used.

1S5	6BF6	12SF7	12BF6	12AV6	19T8	6SR7	1U5
7B6	1LH4	12SR7	6AL5	12AL5	6AT6	12SQ7	6T8
1H5	6SQ7	7C6	14B6	12AT6	6AQ6	6H6	6AV6
							7A6

Following is a schematic of the general type of second detector and automatic volume control (AVC) circuits that may be encountered. Locate the second detector and its associated circuitry.

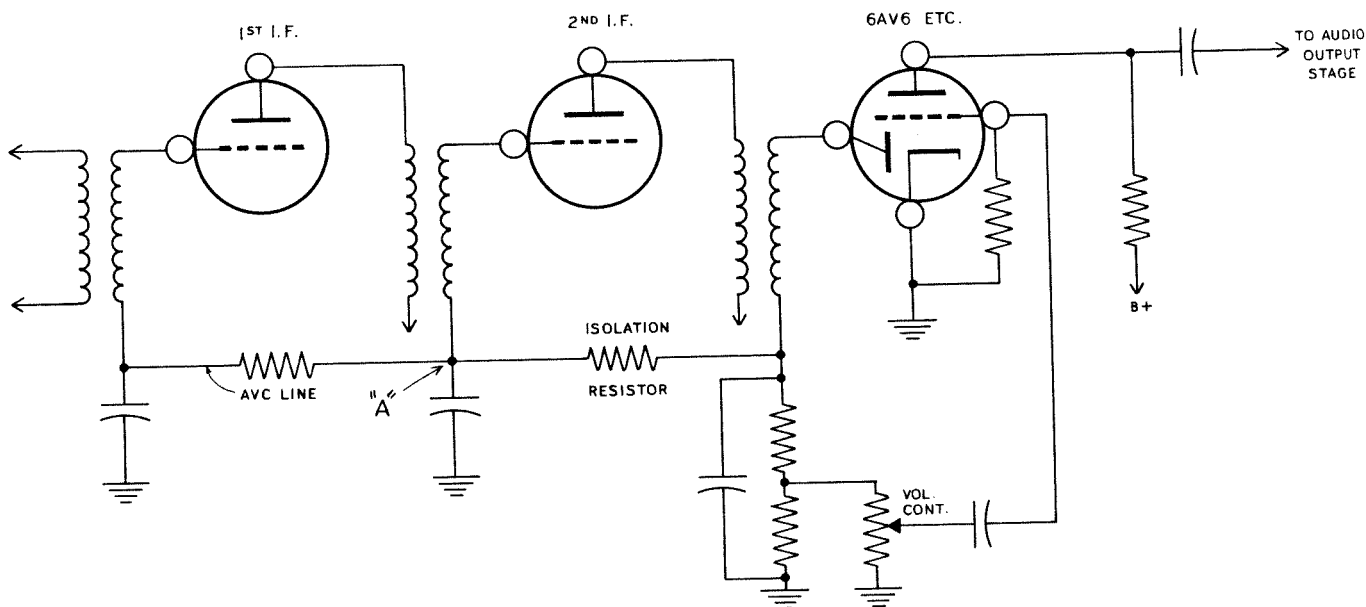

Figure 7

Supplied with the CA-1 are two resistors, a 1 megohm (brown-black-green) and a 10 megohm (brown-black-blue). Just one of these resistors will be needed, depending on the AVC bias voltage developed in the particular receiver to be used. To determine what the AVC bias voltage is, tune the receiver to a signal (preferably a Conelrad key broadcast station which you intend to monitor). Now refer to Figure 6 and you will note that it is common practice to provide a high value of resistance between the detector and the first stage supplied with AVC voltage. This resistor prevents loading of the detector circuit and is marked isolation resistor on the schematic. Also on the schematic there is a point marked (A) which is the point to measure the AVC bias.

- () Use a VTVM or a 20,000 Ω per volt multimeter on the 50 volt scale and measure the AVC bias at this point. If the AVC bias is -15 volts or less the 10 megohm resistor will be used. If the AVC bias is above -15 volts the 1 megohm resistor will be used.
- () Temporarily solder one end of the resistor selected at this point and solder the center conductor of the shielded cable to the other end of the resistor. Solder the braid to the common negative ground. (IMPORTANT: Some AC-DC sets have a common negative ground isolated from the chassis and the shielded braid must be connected to the common negative ground.)

- () Apply power to both the receiver and the CA-1 Conelrad Alarm. Turn the sensitivity control on the CA-1 Conelrad Alarm to the extreme clockwise position. Tune the receiver to the station to be monitored. Be sure to tune the receiver "right on the nose" of the signal being received. Now depress the "reset" button on the CA-1 so that the red warning light goes out. If the warning light fails to stay out after releasing the reset button, adjust the sensitivity control in the counterclockwise direction to the point where the warning light just goes out. Now tune the receiver off of the signal. The warning light should come back on.

Repeat this process a few times to get acquainted with how the CA-1 works. Reset the CA-1 and leave it on for a period of time. If it has a tendency of tripping during normal signal, readjust the sensitivity control still farther in the counterclockwise direction. Be sure to tune the receiver off signal again to make certain that it will trip.

If the CA-1 fails to trip when tuned off signal, the sensitivity control is either adjusted too far in the counterclockwise direction or the noise level of the receiver is too high. To obtain better signal to noise ratio, it may be necessary for those sets that have built-in antennas to rotate the set until the signal increases or hook-up an outside antenna. For those sets that already use an external antenna it may be necessary to either change the direction or location of the antenna. If these methods fail to decrease the noise level, it will be necessary to locate the source of noise and eliminate it.

If the above tests prove satisfactory, remove the "haywire" hookup. A phono socket and plug are furnished to connect the shielded cable to the receiver.

Installing the phono socket will be determined by the type of receiver being used. For those sets that have a common negative ground isolated from chassis, the phono socket cannot be mounted to the chassis. Most receivers have a fiber back and the phono socket could be mounted there. For those sets that use the chassis for common negative ground, mount the phono socket to the chassis.

For those sets where the phono socket is mounted to the chassis connect one end of the resistor selected to the center conductor of the phono socket and solder. Connect the other end to the AVC line (point "A" in Figure 6) and solder.

If the phono socket is not mounted to the chassis, a length of the shielded cable required to reach from the phono socket to the underside of the chassis will be needed. Cut off the required length and strip 3/4" of outer insulation from both ends. Unwind the braid and twist. Strip 5/16" insulation from the inner conductor on both ends. Connect one end to the phono socket, the inner conductor of the cable to the inner conductor of the socket (S) and the braid to the outer conductor of the socket (S).

- () At the other end of the cable, connect the inner conductor to the resistor (S) and the braid to the common ground (S). Make certain the braid cannot short over to other wiring or to the chassis.
- () Strip 1" of outer insulation from the shielded cable coming from the CA-1. Unwind the braid and twist. Strip 3/4" insulation from the inner conductor and tin. Slip the phono plug on the center conductor and solder. Wrap the braid around the outer conductor and solder. When soldering the braid, solder quickly to prevent melting the inner insulation.
- () Replace the receiver chassis back in its cabinet and connect the phono plug to the phono socket installed on the receiver.
- () Connect power to the receiver and the CA-1 Conelrad Alarm. Plug the power plug of the transmitter into the AC socket on the front panel of the CA-1. Turn on the power to the receiver, the CA-1 and the transmitter, leaving the transmitter in STANDBY position. NOTE: The power to the transmitter will not come on until the CA-1 is properly set.

- () Tune the receiver to the station to be monitored push the reset button on the CA-1 and then turn down the volume control on the receiver. The CA-1 Conelrad Alarm is ready for operation.

Always check to see if the CA-1 will trip with loss of signal before going on the air by tuning the receiver off the station. Also have the receiver under your control so that someone else cannot tune the receiver to some other station during the time you are on the air.

If the CA-1 trips while your transmitter is on the air, turn the volume back up on the receiver and check to be sure there is not an alert in progress before putting your transmitter back on the air. If the station you normally monitor is not on the air, and tuning across the broadcast band indicates that other stations are off the air, you can assume that an alert is in progress. Close down your station and tune the broadcast receiver to 640 or 1240 KC. These are the two frequencies used to pass on information during an alert.

False alarms of the CA-1 can be caused by the station momentarily going off the air, or the station may be fading due to ionospheric propagation changes. If fading does occur it may be necessary to monitor a different station.

Make certain to always check the CA-1 Conelrad Alarm for proper operation before going on the air.

It may be desirable to use an external alarm device rather than plugging the transmitter into the CA-1. If this is the case, remove the wire going to terminal #1 of the relay contacts and connect it to terminal #3 of the relay contacts. NOTE: There now will be two wires connected to terminal #3 and no wires to terminal #1 of the relay contacts.

Some suggested methods for an external alarm device would be to use a large wattage light bulb (200 to 500 watts) or a flood lamp. Plug the light bulb or flood lamp into the AC receptacle on the front of the CA-1 and mount the light in the "shack" so that it overrides any existing light when the CA-1 trips.

For an audible alarm, it will be necessary to use a bell, gong, etc. rated at 110 volts. Most bells, gongs, etc. are of the 6 to 8 volt variety, in which case it will be necessary to use a "bell transformer". Plug the transformer into the CA-1 and connect the audible alarm to the 6 to 8 volt terminals on the transformer.

IN CASE OF DIFFICULTY

Mistakes in wiring are the most common cause of difficulty. Consequently, the first step is to recheck all wiring against the pictorials and schematic diagrams. Often having a friend check the wiring will locate an error consistently overlooked.

Also, with miniature sockets there is a possibility of shorts between adjacent socket terminals due to the close spacing. This should be checked and if doubt exists, the terminals should be spread apart until obvious spacing can be seen between them.

Sometimes apparently good solder connections will have an insulating coating of rosin between the wire, the terminal and the solder. This is often the case when insufficient heat was applied in soldering. An ohmmeter check of any questionable connections will test for this condition. Naturally, all voltages should be removed for such tests.

Refer to the circuit description on Page 2 so that "cause and effect" reasoning may be employed as the search for trouble progresses. If some difficulty still persists after the steps outlined have been completed, attempt to localize the trouble.

With the CA-1 disconnected from the receiver and power applied, the red warning light should be on. If the red warning light fails to come on, check the 110 volt 3 watt lamp, relay contacts and associated wiring. With the sensitivity control turned fully clockwise, the neon bulb will glow. Failure to glow indicates trouble in the B+ circuits. Check the pushbutton switch for improper wiring to contacts and ascertain if contacts #1 and #3 are closed. Check wiring of the sensitivity control and all associated circuitry in the B+ line from the power supply.

With the CA-1 connected to the receiver, if the relay fails to pull out when reset, check for proper AVC bias in the receiver and proper setting of the sensitivity control. Check to see if the resistor used to hook into the AVC line is of the right value for the AVC bias developed.

Also check for improper connection of the braid of the shielded cable.

The above checks also should be made if the relay fails to pull in with loss of signal. The 2D21 should also be tested.

REPLACEMENTS

Material supplied with Heathkits has been carefully selected to meet design requirements and ordinarily will fulfill its function without difficulty. Occasionally improper instrument operation can be traced to a faulty tube or component. Should inspection reveal the necessity for replacement, write to the Heath Company and supply all of the following information:

- A. Thoroughly identify the part in question by using the part number and description found in the manual parts list.
- B. Identify the type and model number of kit in which it is used.
- C. Mention the order number and date of purchase.
- D. Describe the nature of defect or reason for requesting replacement.

The Heath Company will promptly supply the necessary replacement. Please do not return the original component until specifically requested to do so. Do not dismantle the component in question as this will void the guarantee. If tubes are to be returned, pack them carefully to prevent breakage in shipment as broken tubes are not eligible for replacement. This replacement policy does not cover the free replacement of parts that may have been broken or damaged through carelessness on the part of the kit builder.

SERVICE

In event continued operational difficulties of the completed instrument are experienced, the facilities of the Heath Company Service Department are at your disposal. Your instrument may be returned for inspection and repair for a service charge of \$3.00 plus the cost of any additional material that may be required. **THIS SERVICE POLICY APPLIES ONLY TO COMPLETED INSTRUMENTS CONSTRUCTED IN ACCORDANCE WITH THE INSTRUCTIONS AS STATED IN THE MANUAL.** Instruments that are not entirely completed or instruments that are modified in design will not be accepted for repair. Instruments showing evidence of acid core solder or paste fluxes will be returned not repaired.

The Heath Company is willing to offer its full cooperation to assist you in obtaining the specified performance level in your instrument. Factory repair service is available for a period of one year from the date of purchase or you may contact the Engineering Consultation Department by mail. For information regarding possible modification of existing kits, it is suggested that you refer to any one or more of the many publications that are available on all phases of electronics. They can be obtained at or through your local library, as well as at any electronic outlet store. Although the Heath Company sincerely welcomes all comments and suggestions, it would be impossible to design, test, evaluate and assume responsibility for proposed circuit changes for specific purposes. Therefore, such modifications must be made at the discretion of the kit builder according to information which will be much more readily available from some local source.

SHIPPING INSTRUCTIONS

Before returning a unit for service, be sure that all parts are securely mounted. Attach a tag to the instrument giving name, address and trouble experienced. Pack in a rugged container, preferably wood, using at least three inches of shredded newspaper or excelsior on all sides. DO NOT SHIP IN THE ORIGINAL KIT CARTON AS THIS CARTON IS NOT CONSIDERED ADEQUATE FOR SAFE SHIPMENT OF THE COMPLETED INSTRUMENT. Ship by prepaid express if possible. Return shipment will be made by express collect. Note that a carrier cannot be held liable for damage in transit if packing, in HIS OPINION, is insufficient.

SPECIFICATIONS

All prices are subject to change without notice. The Heath Company reserves the right to discontinue instruments and to change specifications at any time without incurring any obligation to incorporate new features in instruments previously sold.

WARRANTY

The Heath Company limits its warranty of parts supplied with any kit to a period of three (3) months from the date of purchase. Replacement will be made only when said part is returned postpaid, with prior permission and in the judgment of the Heath Company was defective at the time of sale. This warranty does not extend to any Heathkits which have been subjected to misuse, neglect, accident and improper installation or applications. Material supplied with a kit shall not be considered as defective, even though not in exact accordance with specifications, if it substantially fulfills performance requirements. This warranty is not transferable and applies only to the original purchaser. This warranty is in lieu of all other warranties and the Heath Company neither assumes nor authorizes any other person to assume for them any other liability in connection with the sale of Heathkits.

The assembler is urged to follow the instructions exactly as provided. The Heath Company assumes no responsibility or liability for any damages or injuries sustained in the assembly of the device or in the operation of the completed instrument.

HEATH COMPANY
Benton Harbor, Michigan

LIST OF CONELRAD KEY STATIONS

Radio stations (other than standard, FM and TV broadcast stations) may monitor any standard, FM or TV broadcast station to receive the Conelrad radio alert. In the event the broadcast station normally used to receive the alert is off the air or cannot be heard, key stations may be used to receive the alert. It is recommended though to use the key stations when possible. Local time under the heading "operating schedule" signifies either standard or daylight saving, whichever is applicable.

LOCATION	KEY STATION	FREQ.	OPERATING SCHEDULE
Atlanta, Ga.	WSB	750 KC	24 hours daily except Mondays and Tuesdays from 0100 to 0515 EST.
Baltimore, Md.	WBAL	1090 KC	24 hours daily except Sundays from 0400 to 0800 and Mondays from 0005 to 0500 local time.
Boston, Mass.	WBZ	1030 KC	24 hours daily except Mondays from 0000 to 0500 local time.
Boston, Mass.	WHDH	850 KC	24 hours daily except Tuesdays from 0300 to 0500 local time.
Buffalo, N. Y.	WKBW	1520 KC	24 hours daily except Sundays from 0400 to 0730, Mondays from 0135 to 0600, and Tuesdays from 0400 to 0600 local time.

LOCATION	KEY STATION	FREQ.	OPERATING SCHEDULE
Charlotte, N. C.	WBT	1110 KC	Mondays and Thursdays 0514 to 1209; Tuesdays and Wednesdays 0514 to 1210; Fridays 0514 to 1203; Saturdays 0514 to 0102; and Sundays from 0759 to 1206.
Chicago, Ill.	WGN	720 KC	24 hours daily except Sundays from 0105 to 0630 local time.
Chicago, Ill.	WMAQ	670 KC	Sundays only from 0105 to 0645 local time.
Cincinnati, Ohio	WLW	700 KC	24 hours daily except Mondays and Tuesdays from 0200 to 0428 local time.
Cincinnati, Ohio	WCKY	1530 KC	24 hours daily except once every two months from 0100 to 0600 EST.
Dallas, Texas	KRLD	1080 KC	24 hours daily except Mondays from 0000 to 0530 CST.
Dallas, Texas	WFAA/WBAP	820 KC	24 hours on Monday only.
Denver, Colo.	KMIN	950 KC	24 hours daily except Mondays from 0000 to 0530 MST.
Des Moines, Iowa	WHO	1040 KC	24 hours daily except Sundays from 0030 to 0800 CST.
Detroit, Mich.	WJR	760 KC	24 hours daily except once every three or four months from 0200 to 0400 local time.
Duluth, Minn.	KDAL	610 KC	24 hours daily except Mondays from 0000 to 0600 CST.
Forth Worth, Tex.	KXOL	1360 KC	24 hours daily.
Houston, Tex.	KXYZ	1320 KC	24 hours daily except Mondays from 0015 to 0530 CST.
Kansas City, Mo.	KCMO	810 KC	24 hours daily except Mondays from 0000 to 0500 CST.
Kansas City, Mo.	WHB	710 KC	24 hours daily.
Los Angeles, Calif.	KFI	640 KC	24 hours daily except Mondays from 0001 to 0530 current local time. (NOTE: This station is on one of the Conelrad frequencies. It would be advisable to use some other station to control the CA-1.)
Los Angeles, Calif.	KMPC	710 KC	24 hours daily except Tuesdays from 0100 to 0500 current local time.
Los Angeles, Calif.	KNX	1070 KC	24 hours daily except Tuesdays from 0105 to 0525 current local time.
Minneapolis, Minn.	KSTP	1500 KC	24 hours on Sundays and Mondays only.

LOCATION	KEY STATION	FREQ.	OPERATING SCHEDULE
Minneapolis, Minn.	WCCO	830 KC	24 hours on Sundays only.
Minneapolis, Minn.	WLOL	1330 KC	24 hours daily except Mondays from 0000 to 0500 CST.
Minneapolis, Minn.	WTCN	1280 KC	24 hours daily except Mondays from 0000 to 0500 CST.
Nashville, Tenn.	WLAC	1510 KC	24 hours daily except Sundays from 0300 to 0700 and Mondays from 0000 to 0400 CST.
Nashville, Tenn.	WSM	650 KC	24 hours daily, seven days per week.
New Orleans, La.	WWL	870 KC	On air continuously from 0500 to 0100 Monday through Sunday.
New York, N. Y.	WABC	770 KC	Monday through Saturday normal program 0545 to 0100. Sunday normal program 0755 to 0100 Monday and 400 cycle tone from 0105 Monday to 0434 Monday.
New York, N. Y.	WCBS	880 KC	24 hours daily except Mondays from 0105 to 0530 local time.
New York, N. Y.	WRCA	660 KC	24 hours daily except Mondays from 0100 to 0526 local time.
New York, N. Y.	WOR	710 KC	24 hours daily, seven days per week.
Omaha, Neb.	KFAB	1110 KC	24 hours daily except Mondays from 0000 to 0500 CST.
Omaha, Neb.	KOIL	1290 KC	24 hours daily except Mondays from 0100 to 0400 CST.
Omaha, Neb.	WOW	590 KC	24 hours daily except Mondays from 0100 to 0600 CST.
Philadelphia, Penn.	WCAU	1210 KC	24 hours daily except Mondays from 0105 to 0500 local time.
Philadelphia, Penn.	WIP	610 KC	24 hours daily, seven days per week.
Phoenix, Ariz.	KOY	550 KC	24 hours daily except Sundays from 0100 to 0700 and Mondays from 0000 to 0430 MST.
Phoenix, Ariz.	KPHO	910 KC	24 hours daily except Mondays from 0000 to 0400 MST.
Pittsburgh, Penn.	KDKA	1020 KC	24 hours daily except Mondays from 0015 to 0530 local time.
Portland, Ore.	KEX	1190 KC	24 hours daily except Mondays from 0001 to 0530 current local time.

LOCATION	KEY STATION	FREQ.	OPERATING SCHEDULE
Richmond, Va.	WRVA	1140 KC	24 hours daily except Mondays from 0005 to 0530 local time.
Rochester, N. Y.	WHAM	1180 KC	24 hours daily. Maintenance period if necessary will be on Sundays from 0100 to 0800 local time. Tone modulation between 0300 and 0530 local time.
Sacramento, Calif.	KFBK	1530 KC	24 hours daily except Monday from 0100 to 0500 current local time.
St. Louis, Mo.	KMOX	1120 KC	24 hours daily except Mondays from 0000 to 0530 CDST.
St. Petersburg, Fla.	WTSP	1380 KC	24 hours daily except Mondays from 0000 to 0500 EST.
Salt Lake City, Utah	KSL	1160 KC	24 hours daily except Thursday from 0115 to 0600 MST.
San Antonio, Tex.	KONO	860 KC	24 hours daily except Tuesdays from 0000 to 0500 CST.
San Francisco, Calif.	KCBS	740 KC	24 hours daily except Mondays from 0001 to 0515 current local time.
San Francisco, Calif.	KNBC	680 KC	24 hours daily except Thursday and Friday from 0001 to 0535 current local time.
Schnectady, N. Y.	WGY	810 KC	24 hours daily except Fridays from 0100 to 0430 local time.
Seattle, Wash.	KIRO	710 KC	1, 3, 5, 7, 9, etc. weeks, 0001 through sign-on time by KOMO (alternate weekly continuous operation).
Seattle, Wash.	KOMO	1000 KC	2, 4, 6, 8, 10, etc. weeks, 0001 through sign-on time by KIRO (alternate weekly continuous operation).
Seattle, Wash.	KING	1090 KC	Continuous backup of the above schedules of KIRO and KOMO by KING, daily, except 0001 to 0515 Mondays. (On Tuesdays, KING operates with auxiliary transmitter from 0001 to 0515.)
Washington, D. C.	WTOP	1500 KC	24 hours daily except Mondays from 0005 to 0530 local time.
Washington, D. C.	WWDC	1260 KC	24 hours daily except Mondays from 0001 to 0600 local time.

PARTS LIST

PART No.	PARTS Per Kit	DESCRIPTION	PART No.	PARTS Per Kit	DESCRIPTION
Resistors			Metal Parts		
1-20	1	10 K Ω 1/2 watt	90-39	1	Cabinet
1-26	1	100 K Ω 1/2 watt	200-M124	1	Chassis
1-29	1	220 K Ω 1/2 watt	203-117	1	Panel
1-35	1	1 megohm 1/2 watt			
1-40	1	10 megohm 1/2 watt	Miscellaneous		
1-2A	1	1000 Ω 1 watt	73-1	3	3/8" rubber grommet
1-30A	1	220 K Ω 1 watt	73-4	2	5/16" rubber grommet
11-6	1	10 K Ω W. W. control	89-4	1	Line cord
			261-1	4	Rubber feet
Capacitors			343-3	1	length Shielded cable
21-14	1	.001 μ fd 600 v. disc ceramic	344-6	1	length Hookup wire
25-7	1	20 μ fd +20 μ fd 150 v. dual electrolytic	346-1	1	length Sleeving
			421-4	2	8 amp. 8 AG fuse
			434-69	1	Pilot light clear complete assembly
Sockets-Terminal Strips-Knobs-Plugs			434-71	1	Pilot light red complete assembly.
431-2	3	2-lug terminal strip	595-166	1	Manual
431-10	1	3-lug terminal strip			
434-34	1	7-pin miniature socket			
434-20	1	AC receptacle			
434-42	1	Phono socket			
438-4	1	Phono plug			
438-11	1	AC fused plug			
462-19	1	Small pointer knob			
Switches-Tube-Transformer-Rectifier-Relay					
54-2	1	Power transformer			
57-13	1	Selenium rectifier at 35 ma.			
61-3	1	DPST toggle switch			
64-1	1	Push button switch			
69-3	1	Relay 3.8 K Ω coil SPDT 6 amp contacts			
411-103	1	2D21 type tube			
412-2	1	120 volt 3 watt lamp			
412-3	1	NE51 neon lamp			
Hardware					
250-8	2	#6 sheet metal screw			
250-9	2	6-32 x 3/8" RH machine scw.			
250-31	11	6-32 x 1/4 RH machine scw.			
250-49	2	3-48 x 1/4" BH machine scw.			
252-1	2	3-48 nut			
252-3	10	6-32 nut			
252-7	3	3/8 x 32 nut			
253-10	2	3/8" flat washer			
254-1	13	#6 lockwasher			
254-5	1	3/8" lockwasher			
254-7	2	#3 lockwasher			
259-1	2	#6 solder lug			
259-6	1	#6 small solder lug			
259-10	1	Control solder lug			