

ASSEMBLING AND
USING YOUR

Heathkit

Condenser Checker
Model C-2



THE HEATH COMPANY
BENTON HARBOR, MICH.

PRICE \$1.00

HEATHKIT CONDENSER CHECKER

MODEL C-2

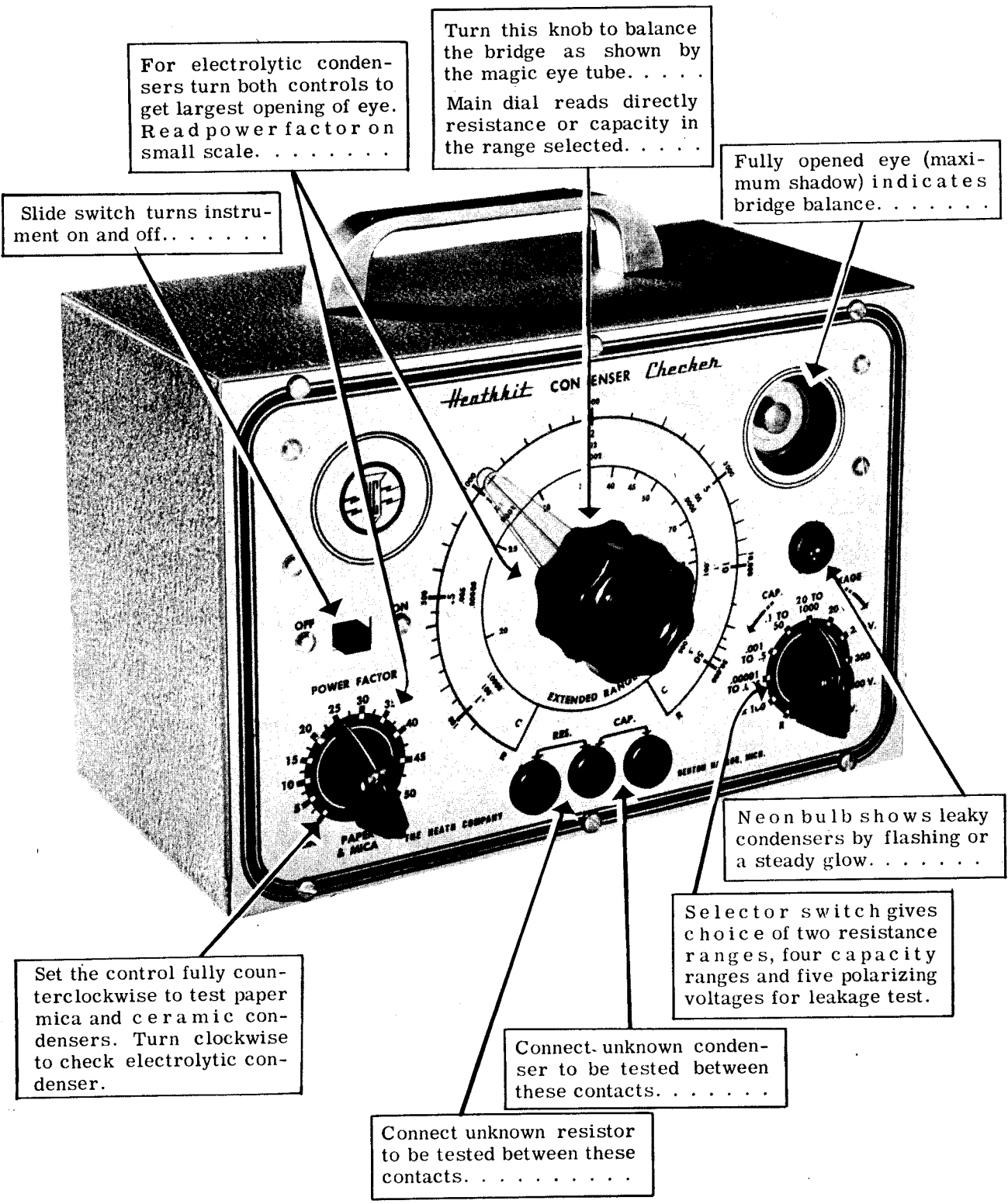

For electrolytic condensers turn both controls to get largest opening of eye. Read power factor on small scale.

Turn this knob to balance the bridge as shown by the magic eye tube. Main dial reads directly resistance or capacity in the range selected.

Fully opened eye (maximum shadow) indicates bridge balance.

Slide switch turns instrument on and off.

Neon bulb shows leaky condensers by flashing or a steady glow.

Selector switch gives choice of two resistance ranges, four capacity ranges and five polarizing voltages for leakage test.

Set the control fully counterclockwise to test paper mica and ceramic condensers. Turn clockwise to check electrolytic condenser.

Connect unknown condenser to be tested between these contacts.

Connect unknown resistor to be tested between these contacts.

ASSEMBLY OF THE HEATHKIT

MODEL C-2

CONDENSER CHECKER

This instrument uses a bridge circuit, operating on 50/60 cycles, for the measurement of capacity and resistance. Leakage is checked with a neon bulb circuit. Polarizing voltage for leakage test is available for condenser ratings from 20 volts to 500 volts. Standards used are three condensers and three resistors of the necessary accuracy. The operating voltages are obtained from the 117V 50/60 cycle AC line ONLY through a power transformer and half wave rectifier. A magic eye tube is used to indicate the "null" or balance of the bridge.

It is not difficult to construct this instrument if the instructions are carefully followed. Read the manual fully through before starting the assembly.

Begin by checking the parts against the parts list. Identify each part, using the charts on the inside of the cover of this manual where necessary. Thus you will avoid throwing away any small parts with the packing.

Familiarize yourself with the layout by studying the pictorial diagram and the photo prints. Then proceed by following the step-by-step assembly instructions.

Read the note on soldering on the inside of the back cover. Make a good mechanical joint of each connection with clean metal to clean metal. Use only good quality Rosin Core Radio Type solder. Pastes or acids are difficult to remove and minute amounts left combine with moisture from the air forming a corrosive product. Weeks or months later corrosion may result in untimely failure.

NOTE: ALL GUARANTEES ARE VOIDED AND WE WILL NOT REPAIR OR SERVICE INSTRUMENTS IN WHICH ACID CORE SOLDER OR PASTE FLUXES ARE USED.
(When in doubt about solder, it is recommended that a new roll plainly marked "Rosin Core Radio Solder" be purchased.)

The tube socket pins are numbered from 1 to 8 starting at the keyway and reading clockwise when viewed from the bottom.

Resistors and controls have a tolerance rating of plus or minus 20% unless otherwise stated. Therefore a 100K ohms resistor may test between 80K ohms and 120K ohms. Frequently, condensers show an even greater variation such as minus 50% to plus 100%. This Heathkit is designed to accommodate such variation.

Small changes in parts may be made by the Heath Company. All parts supplied will work just as well as the part for which it was substituted. All substitutions will be of equal or better quality than the original, and will be made in order that a minimum delay will occur in filling your order.

The capacity standards C44, C15 and C16 are carefully selected to provide the required accuracy. C15 consists of a matched pair of .01 MFD condensers. Do not separate.

STEP BY STEP ASSEMBLY

(S) means solder the connection. (NS) means do not solder yet.

1. Mount the tube sockets (O54) with the tube socket rings (O43) on the chassis (C29) with the keyway away from the flange as shown in the pictorial. Mount the power transformer (C27) with 6-32 screws, using a solder lug under the nut near the chassis flange, and a dual terminal strip (S32) under the screw head and a lock washer under the nut on the side away from the flange. Install the $\frac{3}{8}$ rubber grommet (O35) in the hole provided in the chassis.
2. On the panel (C28A) mount the three banana jacks (V77B&R) (the red jack in the middle) with speed nuts (O44) as shown. Mount the slide switch (O94) with 6-32 screws, using lockwashers under the nuts. Mount the main control (C18) and power factor control (C19) with control nuts, using a lock washer between control and panel and a nickel washer between panel and nut. Install the 7/16 rubber grommet (C24) in the hole provided in the panel.

3. Wire up the selector switch (C20A) as far as possible before mounting. On the front deck (nearest the knob shaft) with bare wire join contacts #1, 2, 3, 4, 5, and 6. (S) all except #1 (NS). A 30K resistor (C13) to contacts #7 (NS) and #8 (NS). A 30K resistor to contacts #8 (NS) and #9 (NS). A 30K resistor to contacts #9 (S) and #10 (NS). A 30K resistor to contacts #10 (S) and #11 (NS).

On the rear deck a 200 condenser (C16) to contact #3 (S) and #9 (NS). A .02 matched pair condenser (C15) to contact #4 (S) and #9 (NS). A 90K precision resistor to contact #8 (NS) and #9 (NS).

4. Mount the partially wired selector switch on the panel with a control nut, using a control lock-washer between switch and panel and a nickel washer between nut and panel. Before tightening the nut securely, fasten a pointer knob to the shaft temporarily. Turn the switch so the rotor connects to contact #1 (as shown in pictorial). Now turn the whole switch assembly so the knob points at the "R" marking on the panel. Carefully remove knob and tighten mounting nut.
 5. Assemble both end brackets (C30) to panel as shown using 6-32 screws. Use lock washers under the nuts and mount one single terminal strip (O38) under the lock washer nearest the selector switch. Mount two single terminal strips (O38) to the end bracket nearest the slide switch, using 6-32 screws and lock washers under the nuts. Install the banana jack inserts by pushing them into the banana jacks from the front of the panel as far as possible. Install neon lamp (SG22) in lamp socket and insert lamp partly through grommet in panel.
 6. A 200k resistor (V11) to single terminal near neon lamp socket (NS) and to contact #12 on rear deck of selector switch (NS). A wire to contact #12 (S) and to center (red) banana jack (NS). A 30k resistor (C13) to center (red) banana jack (S) and to farthest switch terminal on power factor control (S). A wire to center switch terminal on power factor control (S) and to contact #12 on front deck of selector switch (NS). A wire to contact #12 (S) and to one lug on lamp socket (S). A wire to other lug on lamp socket (S) and to adjacent terminal strip (NS). Note: Make the wires to the lamp socket long enough to permit removal of the lamp if such should be necessary.
 7. A .5 condenser (C17) to terminal strip near neon lamp (S) and to nearest switch terminal on power factor control (S). A wire to nearest terminal of power factor control (S) and to adjacent banana jack (NS). A wire to banana jack adjacent to power factor control (S) and to contact #9 on rear deck of selector switch (S). A wire to contact #8 on rear deck of selector switch (S) and to farthest terminal of main control (S).
 8. A 2 MFD precision condenser (C44) between the single terminal strips on the end bracket (NS). A wire to the terminal strip on the end bracket nearest the panel (S) and to center terminal of power factor control (S). A wire to terminal strip on the end bracket farthest from the panel (S) and to contacts #5 and #6 on rear deck of selector switch (S). A 68-75K resistor (C41) to contact #7 on front deck (S) and to center terminal of the main control (NS).
 9. Mount the assembled chassis to the end brackets with 6-32 screws, using lockwashers under the nuts. Wire the filament circuit as follows: The two yellow leads from the transformer twisted together and one wire to pin #2 (NS) and the other to pin #7 (NS) on 12A6 socket. Two wires to pin #2 (S) and pin #7 (S) on 12A6 socket and, after twisting them together, to pin #2 (S) and pin #7 (S) on 1629 socket. One red transformer lead to pins #3, #4 and #5 (S) on 12A6 socket. Other red transformer lead to solder lug (NS). A wire to pin #1 on 12A6 socket (NS) and to solder lug (NS). A wire to pin #8 on 1629 socket (NS) and to solder lug (S).
 10. Twist black transformer leads partly together, one wire to a lug on slide switch (S), other lead to lug nearest slide switch on dual terminal strip (NS). A wire to pin #1 on 12A6 socket (NS) and to center terminal on main control (S). An 8 MFD condenser (O50) with negative lead to pin #1 on 12A6 socket (S), positive lead to pin #4 on 1629 socket (NS). An 8 MFD condenser (O50) with negative lead to pin #4 on 1629 socket (NS), positive lead to pin #8 on 12A6 socket (NS).
- Note: Use spaghetti over the condenser leads to prevent accidental contact to other leads and lugs.
11. A wire to pin #8 on 12A6 socket (S) and to contact #11 on front deck of selector switch (S). A wire to pin #4 on 1629 socket (NS) and to contact #8 on front deck of selector switch (S). A wire to pin #1 on 1629 socket (NS) and to contact #1 on front deck of selector switch (S).

A 10 Meg resistor (C10) to pin #8 (S) and pin #5 (NS) on 1629 socket. A 1 Meg resistor (O17) to pin #4 (S) and pin #3 (S) on socket 1629. A .01 MFD condenser (T13) to pin #5 (S) and to pin #1 (S) on 1629 socket.

12. A wire to lug nearest selector switch on dual terminal strip (NS) and to terminal of main control nearest selector switch (NS). A wire to terminal of main control (S) and to banana jack (S) nearest selector switch. A 2K-1W precision resistor (C42) to contact #1 on rear deck of selector switch (S), and to nearest lug on dual terminal strip (NS). A 200K precision resistor (V64) to contact #2 on rear deck of selector switch (S), and to nearest lug on dual terminal strip (NS).
13. Temporarily connect the green leads from the transformer (do not shorten yet) one lead to contact #10 on rear deck of selector switch (S), other lead to lug nearest selector switch on dual terminal strip (S). (These leads may have to be inter-changed as determined by the initial test.) Place the line cord (O78) through the rubber grommet in the chassis, tie a strain relief knot on the inside and connect one lead to nearest lug on dual terminal strip (S), other lead to a lug on the slide switch (S).

INITIAL TEST

Check the wiring carefully. We suggest following each wire and tracing over the corresponding wire on the pictorial diagram with a colored pencil. Check each solder connection.

Plug the unit into a 117 volt 50/60 cycle AC outlet ONLY. This unit will not operate and serious damage will result if connected to DC. Turn unit on and allow a minute for warm up. The tuning eye should light up to a bright green.

Set selector switch to the high resistance range (Rx 100) and connect the calibrating resistor to the "Res" jacks. Adjust the main control so that the eye opens. Set pointer to indicate the resistance of the calibrating resistance, and tighten the set screw. The pointer travel should now be practically the full length of the dial scale.

Set selector switch to the lowest capacity range. Without test leads inserted into the banana jacks, check to determine if a null can be obtained at the low end of the scale.

Note the capacity indicated at balance. This small value (5-30 MMF) is the inherent minimum capacity. When making accurate capacity measurements on the lowest range, subtract this value from the indicated value. If null is not obtained, reverse green transformer leads. For greatest accuracy on this lowest range, insert the leads of the condenser directly into the banana jacks. This will eliminate errors caused by the test leads.

14. Properly connect the green transformer leads. Prepare the cabinet by installing the handle (O79) with two 10-24 screws, and pushing the rubber feet in the bottom holes. Install the instrument in the cabinet with six #6 sheet metal screws. This completes the instrument.

OPERATION OF THE HEATHKIT MODEL C-2 CONDENSER CHECKER

The resistance bridge operates on AC of the line frequency. The bridge consists of the ratio arms formed by the main control, one of two standard resistors (C42 or V64) and the unknown. Connect the unknown to the jacks marked RES. Set the selector switch to R or R x 100 range and adjust main control for maximum shadow of the tuning eye. Read resistance on main dial and add two zero's if R x 100 range is used.

The capacity bridge operates on AC of the line frequency. The bridge consists of the ratio arms formed by the main control, one of three standard condensers and the unknown. Connect the unknown to the jacks marked CAP. Set the selector switch to the proper range and adjust main control for maximum shadow of the tuning eye. Read capacitance on main dial considering the position of the selector switch.

The extended range expands the high capacity end of the dial by adding resistance in series with one side of the main control.

Electrolytic condensers frequently have a certain amount of internal resistance in series with the capacity. To balance the bridge it is necessary to balance such resistance with resistance in series with the standard condenser (power factor control). As electrolytic condensers are only found in the higher capacity values, the control only functions on the high and extended ranges.

The leakage test places a test voltage on the condenser through a neon bulb circuit. Leakage is indicated by rapid flashing or a steady glow. An occasional flash indicates only slight leakage and even perfect condensers frequently cause a flash during the initial charging surge. As electrolytic condensers have an inherent leakage the switch on the power factor control suitably decreases the sensitivity of the neon bulb circuit. Set the selector switch to the rated voltage of the condenser. The applied voltage, while proper for such test, is not necessarily the same as the rated voltage of the condenser.

Note: On electrolytic condensers observe polarity: positive (+) terminal to red (center) jack.

The power factor is a measure of the energy loss in an imperfect condenser. In filter applications a higher power factor decreases the effective capacity so that the effective capacity at 20% power factor is 98% of the measured capacity. At 30% power factor the effective capacity is decreased to 95%, while at 50% power factor the effective capacity is decreased to 87% of the measured capacity.

A condenser which will not balance on any of the ranges but allows the eye to open on the low end of the low range is open, while one which allows the eye to open on the high end of the high ranges is shorted.

CAUTION: Never leave the leads shorted together or connected to a shorted condenser as the prolonged drain may damage the instrument.

CAUTION: NEVER CHANGE THE TEST LEADS WHEN SELECTOR SWITCH IS IN LEAKAGE TEST POSITION AS THIS MAY RESULT IN SEVERE SHOCK.

Connect and disconnect test leads with the selector switch knob pointing straight down. In this position the center (positive) terminal is disconnected.

NOTE that the tolerance of many types of condensers is quite wide. While small ceramic and mica condensers used in tuned circuits sometimes have a tolerance of $\pm 2\%$, condensers for blocking or by-pass applications seldom are rated closer than $\pm 20\%$. Frequently tolerances of - 50% to + 100% are encountered for by-pass and filter condensers. Many of the ceramic by-pass condensers are specified with a guaranteed minimum capacity.

NOTE: 1K ohm is 1,000 ohms 1 Meg ohm is 1,000,000 ohms
1 MFD (or 1 MF) (microfarad) is 1,000,000 MMF (micromicrofarad)

IN CASE OF DIFFICULTY

1. Recheck entire wiring. Most cases of difficulty result from wrong or reversed connections.
2. Check the AC voltages from the transformer: yellow to yellow: 9-12 VAC; green to green: 40-60 VAC; red to red: 400-500 VAC; from pin #8 on 12A6 socket to chassis 450-600 VDC.
3. Recheck the wiring of the selector switch. Often having a friend check the wiring will reveal an error consistently overlooked.
4. If you are unable to obtain results, write the Heath Company, giving all possible information such as voltages obtained and indication if any.
5. If desired, your instrument may be returned to the factory. The Heath Company will check your instrument and put it into operating condition for a charge of \$3.00 plus any parts or alterations required due to damaged or improper construction.

NOTE: Before returning your instrument to the factory, be sure to tighten securely all chassis mounting screws. Tighten power transformer securely. Attach a tag, giving name, address and trouble experienced, to your instrument. Pack instrument WITHOUT cabinet in a rugged container, preferably wood, using at least three inches of shredded newspaper or excelsior on all sides. Do not use folded newspaper. Do not ship in original carton only. Ship by prepaid express if possible. Return shipment will be made by express collect. NOTE that a carrier cannot be held liable for damage in transit if packing, in HIS opinion, is insufficient.

WARRANTY

The Heath Company limits its warranty on any part supplied with any Heathkit (except tubes, meters, and rectifiers, where the original manufacturer's guarantee only applies) to the replacement within three (3) months of said part which, when returned with prior permission, postpaid, was, in the judgment of the Heath Company, defective at the time of sale.

The assembler is urged to follow the instructions exactly as provided. The Heath Company assumes no responsibility or liability for any damages or injuries sustained in the assembly of the device or in the operation of the completed instrument.

HEATH COMPANY Benton Harbor, Michigan

C-2 CONDENSER CHECKER PARTS LIST

Part No.	Parts Per Kit	Description	Part No.	Parts Per Kit	Description
Resistors			Controls and Switches		
C42	1	2000 Ohm 1 Watt Precision	C19	1	800 Ohm W. W. Control with SPDT Switch
V69	1	90000 Ohm Precision	C18	1	10000 Ohm W. W. Control
V64	2	200000 Ohm Precision (1 for calibrating)	C20A	1	2 Pole 11 Pos. Rotary Switch
C13	5	30000 Ohm 1 Watt	O94	1	SPST Slide Switch
C41	1	68000-75000 Ohm 1 Watt	Tubes and Lamps		
V11	1	200000 Ohm	C21	1	1629 Eye Tube
O17	1	1 Megohm	K23	1	12A6 Rectifier Tube
C10	1	10 Megohm	SG22	1	NE51 Neon Lamp
Condensers			Hardware		
C16	1	200 MMF Mica Precision	O31	14	6-32 X 3/8 Screws
C15	1	.02 MFD Molded Precision (Matched pair of .01 MFD)	S22	14	6-32 Nuts
C44	1	2 MFD Tubular Precision	7S72	13	#6 Lock Washers
T13	1	.01 MFD Paper	O102	6	#6 Sheet Metal Screws
C17	1	.5 MFD Paper	O30	2	10-24 X 3/8 Screws
O50	2	8 MFD/475V Electrolytic	O37	1	Solder Lug
Wire and Plugs			O33	3	Control Nuts
C26	1	Length Hookup Wire	O101	3	Control Lock Washers
C35	1	Length Spaghetti	O28	3	Control Nickel Washers
C23	1	Length Red Test Lead	O44	3	Speed Nuts
C22	1	Length Black Test Lead	O35	1	3/8 Rubber Grommet
O78	1	Line Cord	C24	1	7/16 Rubber Grommet
V40	1	Red Banana Plug	O34	4	Rubber Feet
V39	1	Black Banana Plug	Miscellaneous		
V44	2	Alligator Clips	G38	1	Indicator Knob
Sockets, Jacks and Terminal Strips			O51	2	Pointer Knobs
O54	2	Octal Sockets	C27	1	Power Transformer
O43	2	Octal Socket Rings	C28A	1	Panel
C25A	1	Lamp Socket	C29	1	Chassis
V77R	1	Red Banana Jack	C30	2	End Brackets
V77B	2	Black Banana Jacks	T32	1	Cabinet
M28	3	Banana Jack Inserts	O79	1	Handle
O38	3	Single Terminal Strips	C2	1	Manual
S32	1	Dual Terminal Strip			

Heathkit CONDENSER CHECKER

MODEL C-2

HEATH COMPANY
BENTON HARBOR, MICH.
1/15/50

C28A

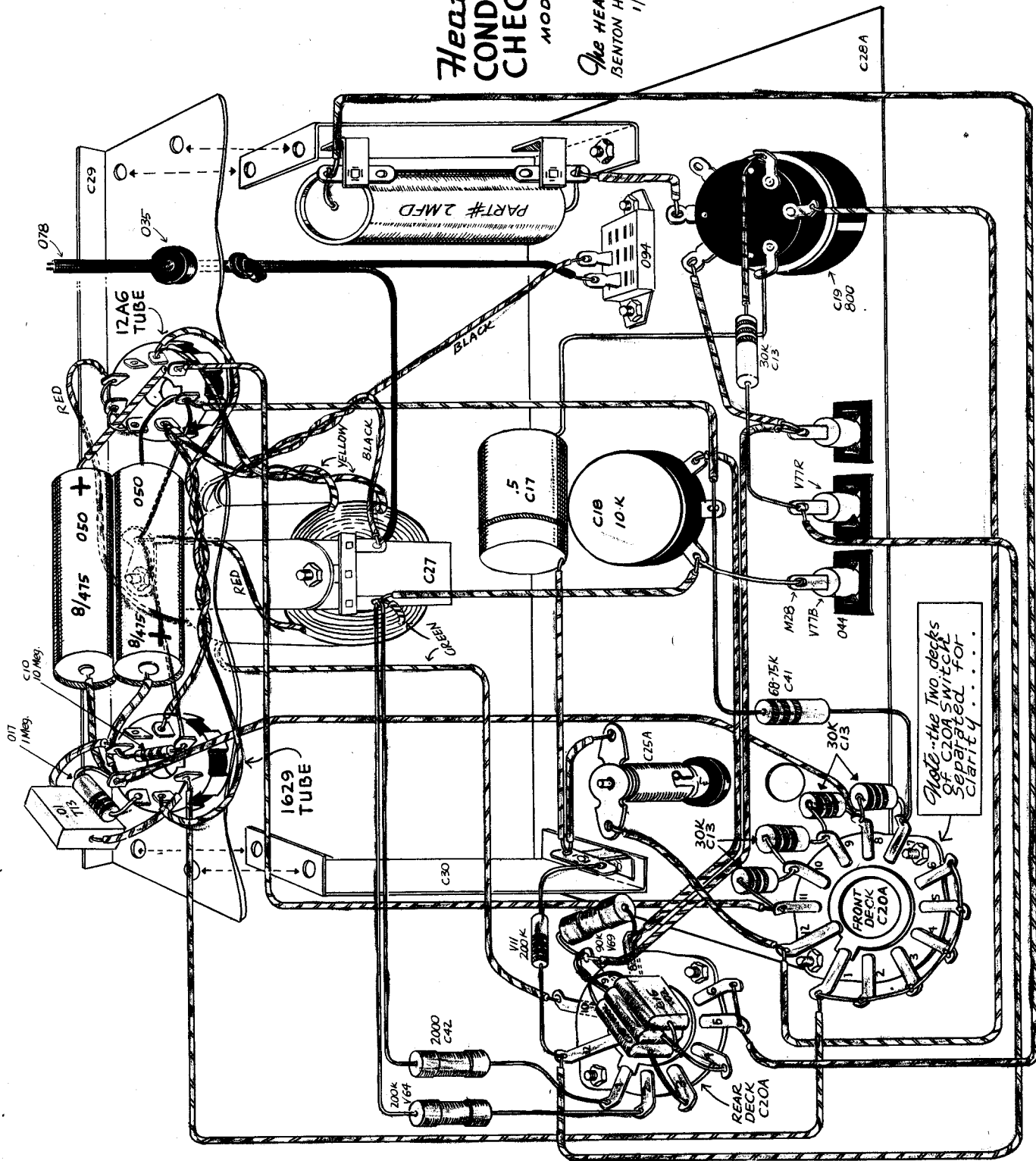

Heathkit CONDENSER CHECKER

MODEL C-2

The HEATH COMPANY
BENTON HARBOR, MICHIGAN

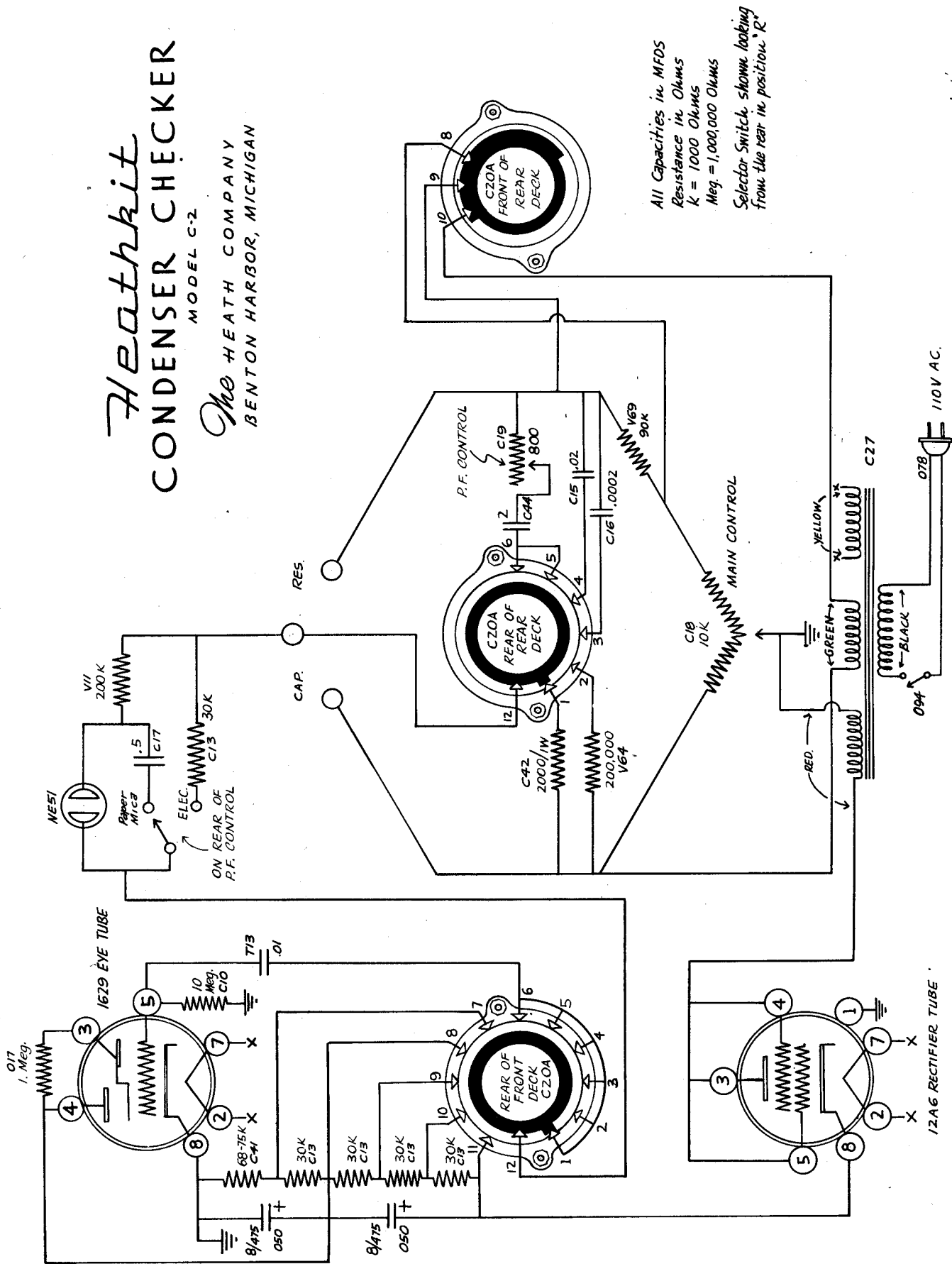

All Capacities in MFDS
Resistance in Ohms
K = 1000 Ohms
Meg. = 1,000,000 Ohms
Selector Switch, shown looking
from the rear in position 'R'

1/15/50

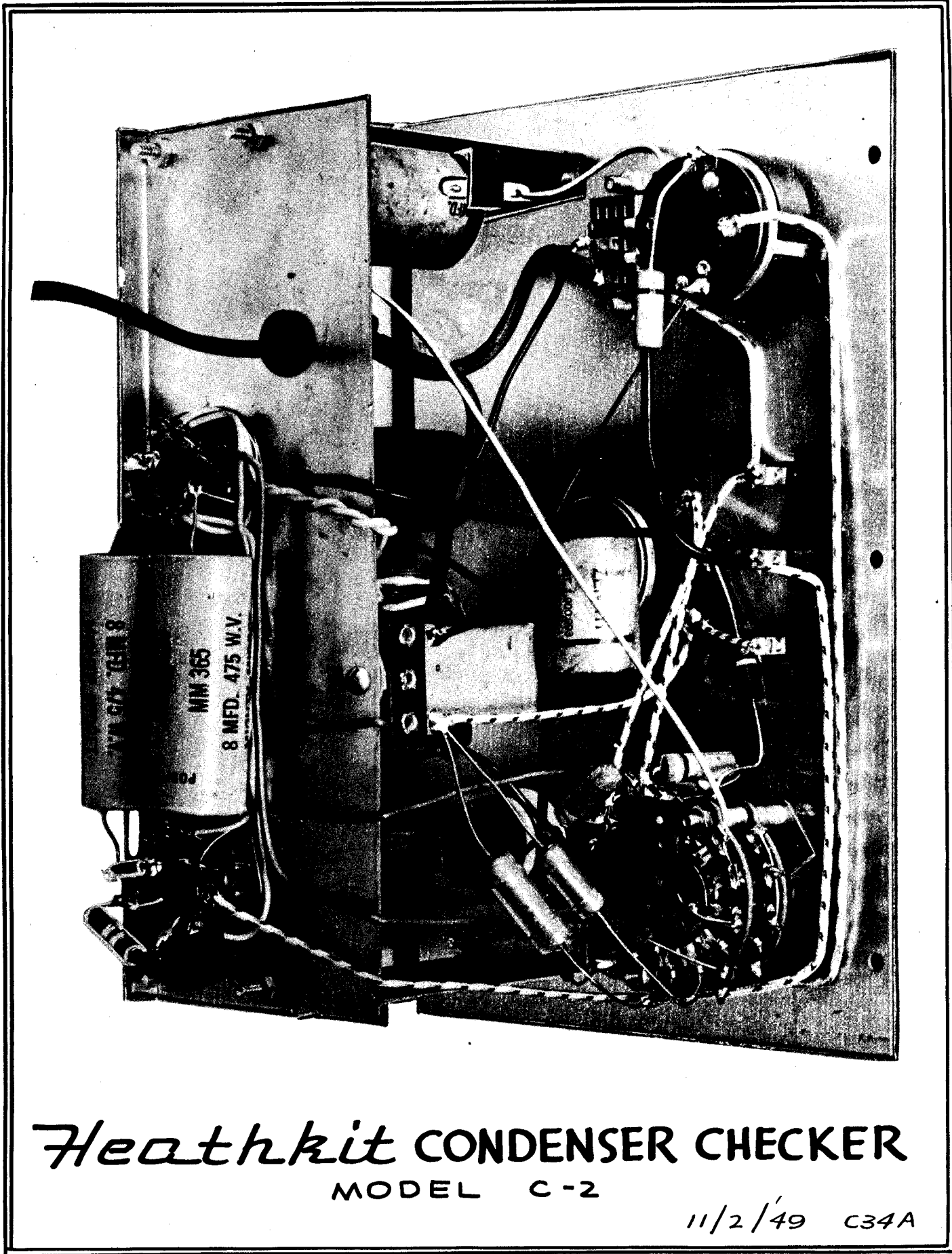

Heathkit CONDENSER CHECKER

MODEL C-2

11/2/49 C34A