

Assembly
and
Operation
of the

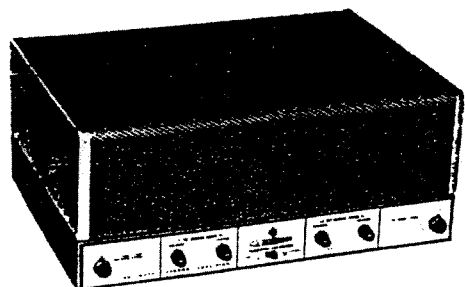

80 WATT
AMPLIFIER
MODEL AA-121



HEATH COMPANY,
WINTON HARBOR,
MICHIGAN

a subsidiary of
DAYSTROM, INCORPORATED

TABLE OF CONTENTS

Specifications.	2
Introduction.	7
Circuit Description.	7
Construction Notes.	10
Parts List.	11
Proper Soldering Techniques.	12
Step-By-Step Procedure.	14
Step-By-Step Assembly.	14
Mechanical Assembly.	14
Initial Wiring.	19
Final Wiring.	25
Initial Test.	29
Final Assembly.	31
Adjustment.	31
Installation and Operation.	32
In Case of Difficulty.	36
Service Information.	37
Warranty.	39
Schematic.	9*

*Fold-out from page listed.

All prices are subject to change without notice. The Heath Company reserves the right to discontinue instruments and to change specifications at any time without incurring any obligation to incorporate new features in instruments previously sold.

THE HEATHKIT 80 WATT AMPLIFIER MODEL AA-121



SPECIFICATIONS

The following specifications are presented in the belief that you are entitled to a factual and comprehensive technical report on the performance of the Model AA-121 Amplifier.

These specifications are based on measurements

made on a number of AA-121 Amplifiers, constructed by individuals who represent various levels of technical skill. The measurements were made under carefully controlled conditions, not to present the most favorable advertising information but in strict accordance with generally accepted standards.

Power Output:

STEREOPHONIC -
40 watts per channel - "high fidelity" rating.
MONOPHONIC -
80 watts - "high fidelity" rating.

FREQUENCY RESPONSE:

±1.0 db from 6 cps to 25,000 cps at 0.25 watt.
±0.5 db from 20 cps to 20,000 cps at 40 watts.
See Graph A.

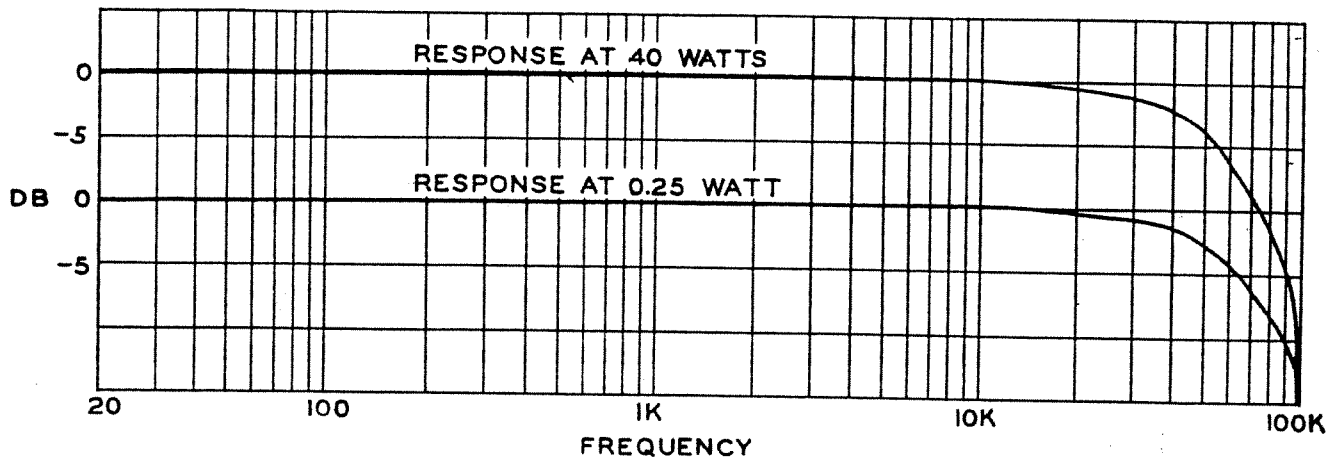

Graph A
Frequency Response

HARMONIC DISTORTION:

1.5% or less from 20 to 20,000 cps at 40 watts.
Less than 0.5% from 20 to 20,000 cps at 10 watts.
See Graph B.

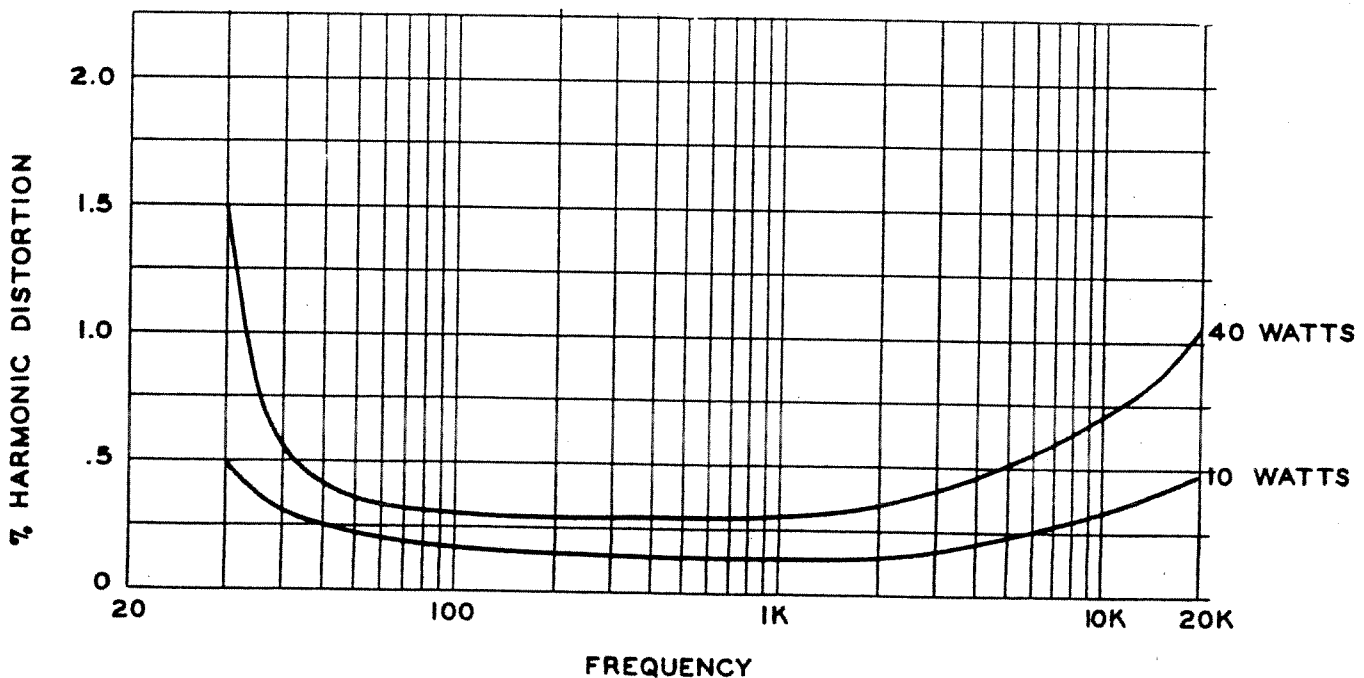

Graph B
Harmonic Distortion

INTERMODULATION DISTORTION:.....
 (Each Channel)

0.5% or less at 40 watts (equivalent single-frequency power) using 60 and 6,000 cps mixed 4:1.
 See Graph C.

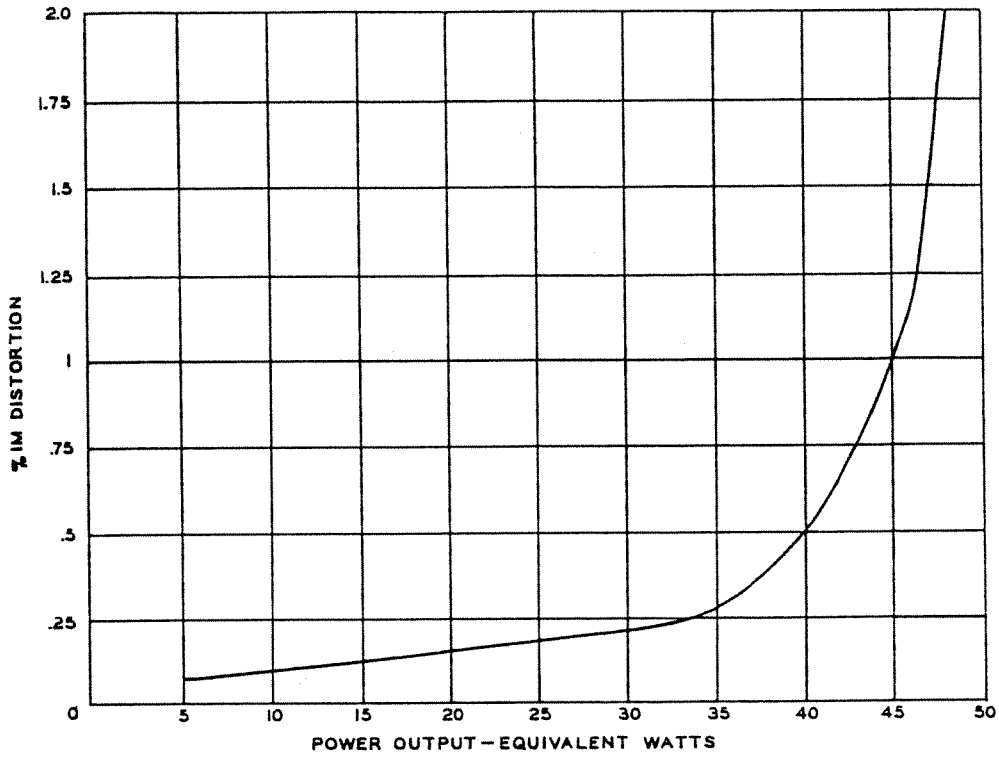

Graph C
 IM Distortion

SENSITIVITY:.....
 (Each Channel)

.95 volts rms for 40 watts.
 See Graph D.

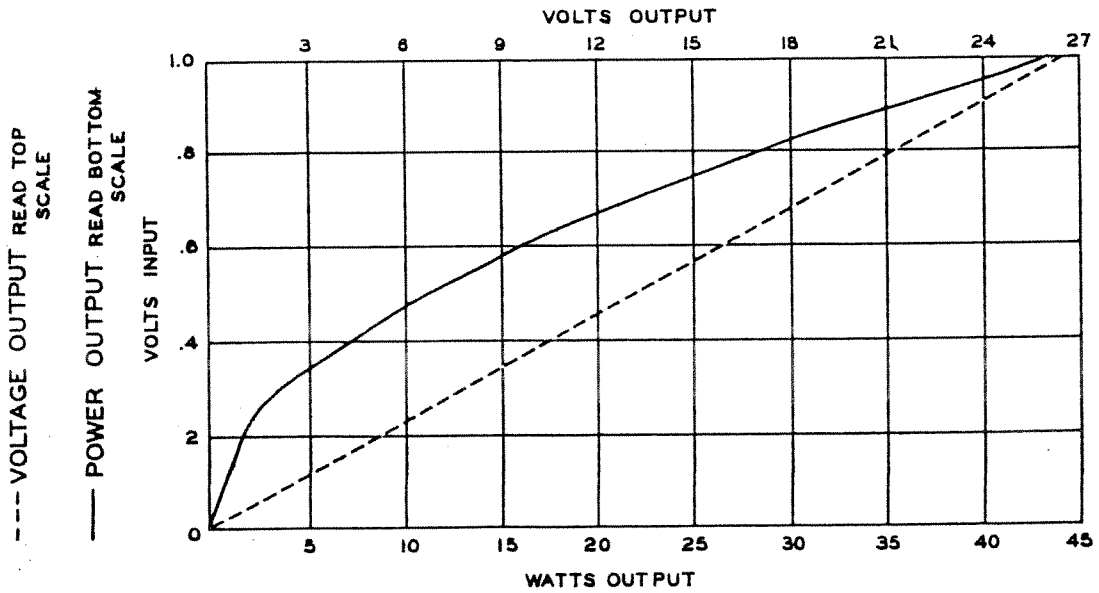

Graph D
 Sensitivity

CHANNEL SEPARATION:	70 db or better at 1,000 cps.
HUM AND NOISE: (Each Channel)	85 db below 40 watts.
OUTPUT TUBE BALANCE: (Each Channel)	BASS-BAL METER jacks on rear chassis apron. Requires only a simple DC voltmeter for indication of exact balance.
FEEDBACK FACTOR:	20.5 db of negative voltage feedback is applied around the entire amplifier and output transformer in each channel.
OUTPUT IMPEDANCES: (Each Channel)	4, 8, 16 and 32 ohms.
DAMPING FACTOR:	16.0 at 8 and 16 ohm taps; 12.5 at 4 ohm tap.
CENTER SPEAKER TERMINALS:	These terminals can be used to operate a 4, 8 or 16 Ω speaker, or speaker system.
MONOPHONIC SPEAKER OPERATION:	The outputs of A and B Channels can be paralleled to provide 70 watts Professional. This type of operation is described in the INSTALLATION AND OPERATION section of the Manual.
PHASE REVERSAL:	A PHASE SELECTOR switch is provided on the rear chassis apron to facilitate reversing the phase of the A Channel output at the speaker terminals.
STABILITY:	With a 10 kc square wave signal, either channel will tolerate any value of capacitance across the output terminals (with no other load) and show no tendency toward oscillation.
TUBE COMPLEMENT:	2 - 6AN8 4 - EL-34
RECTIFIERS:	B+ Supply - Four 500 ma silicon diodes, used in a full-wave voltage doubler arrangement. Bias Supply - Selenium diode rectifier.
INPUT AND OUTPUT CONNECTORS: (Each Channel)	Input - Standard phono jack. Output - Screw type terminal strip.



CONTROLS:

- FRONT APRON-
 - A CHAN. BIAS BALANCE
 - A CHAN. BIAS VOLTAGE
 - B CHAN. BIAS BALANCE
 - B CHAN. BIAS VOLTAGE
 - A CHAN. AND MON. LEVEL
 - B CHAN. LEVEL
 - FUNCTION SELECTOR

MECHANICAL PROTECTION:

The decorative top cover prevents accidental contact with hot tubes; the expanded metal in the top cover provides adequate ventilation.

POWER REQUIREMENTS:

117 volts, 50/60 cycles at 180 to 320 watts.

FINISH:

Chassis - Black enamel
Top Cover - Bronze

DIMENSIONS:

11" deep x 7 1/4" high x 15" wide, overall.
NOTE: For proper ventilation, the minimum clearance dimensions for installation in a cabinet are 15" deep x 9 1/4" high x 19" wide.
CAUTION: Do not remove the plastic feet as they provide ventilation space under the chassis.

WEIGHT:

Net - 35-3/4 lbs.
Shipping - 39 lbs.

TEST CONDITIONS:

Dummy loads - 4, 8, and 16 ohms, ±2% resistive 117 volts, 60 cycles, regulated.

The following test instruments were used to gather these specifications.

Generators:

Krohn-hite Model 440-A.
Hewlett-Packard Model 650-A.

Distortion Measurements:

Hewlett-Packard Model 330-B Distortion Analyzer.

Power Measurements:

HEATHKIT Model AA-1 Audio Analyzer.

Hewlett-Packard Model 400-D Electronic Voltmeter.

Features patented Heath Ultra-Linear® circuit
U. S. Patent #2,710,312

Minor variations from these specifications may be encountered in kit-assembled equipment. Such factors as exact lead placement, component variations, and normal variations in tube char-

acteristics are possible sources of deviations. Such variables will ordinarily have no significant effect on overall performance.

INTRODUCTION

The HEATHKIT Model AA-121 High Fidelity Stereo Amplifier incorporates two complete amplifier channels and a common power supply which provides B+ voltage, negative bias voltage and filament voltage to both channels. Each channel has separate input LEVEL and BIAS adjustment controls. The FUNCTION SELECTOR switch facilitates the selection of either stereo or monophonic operation.

The power output available from this amplifier is adequate to drive practically all speaker systems that will be used for normal high fidelity stereo applications. An optional monophonic speaker connection is also available to allow using the power from both channels to drive a

monophonic speaker network. Monophonic speaker operation is described in detail in the INSTALLATION AND OPERATION section of this manual.

Among the features of the AA-121 Amplifier is a CENTER SPEAKER output. This output can be used with a third speaker system to fill the "hole-in-the-middle" effect present in some stereo program material.

The common, "bus" ground arrangement used in the AA-121 results in low hum and neat wiring. The physical design of this amplifier is such that exceptionally clean component layout will result if the Step-By-Step directions and Pictorials are followed.

CIRCUIT DESCRIPTION

The AA-121 Amplifier Consists basically of three sections, the A Channel amplifier, the B Channel amplifier and the power supply.

The FUNCTIONAL BLOCK DIAGRAM shows signal paths through the amplifier sections and the relationship of each section to the others.

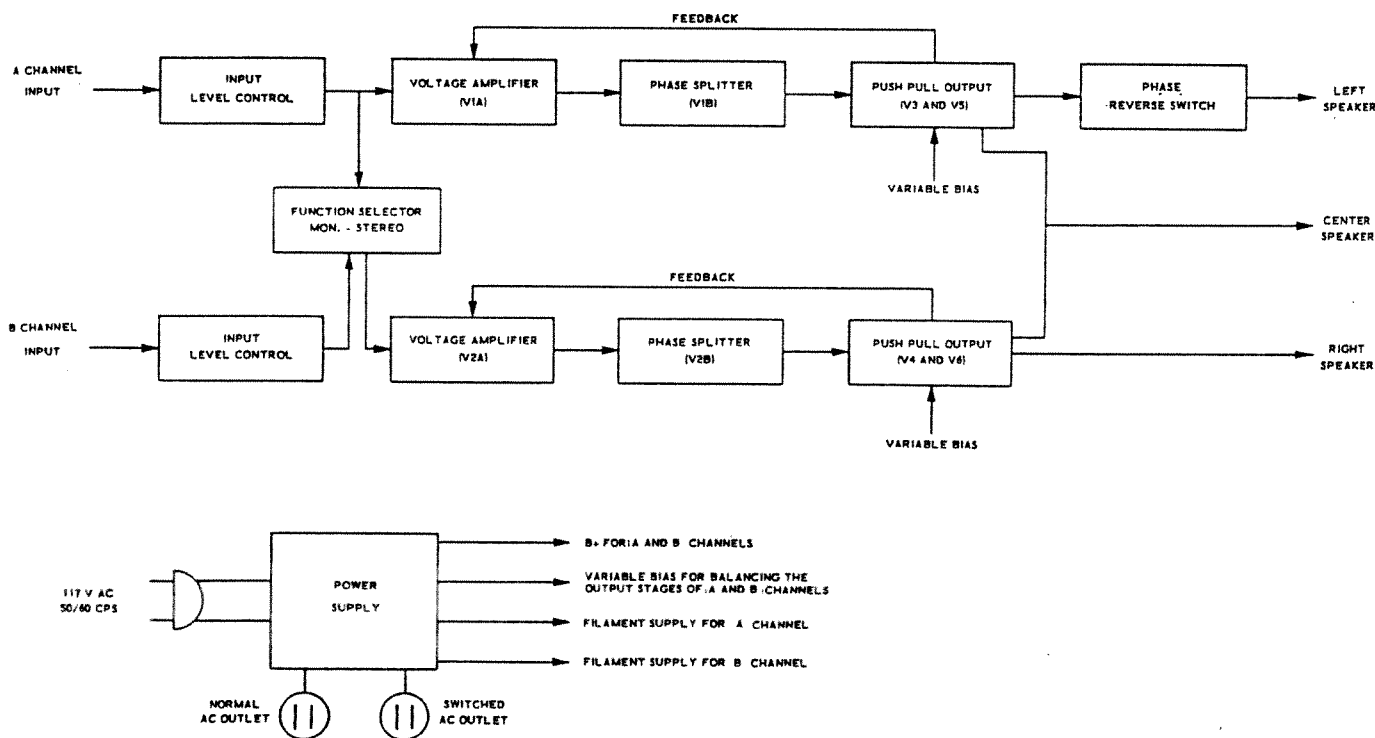

Because A Channel is identical to B Channel, except for output circuitry, only A Channel will be described. While following this description, it will be helpful to occasionally refer to both the FUNCTIONAL BLOCK DIAGRAM and the SCHEMATIC DIAGRAM.

NOTE: For easy distinction between the two channels when referring to the SCHEMATIC DIAGRAM, all of the resistors and capacitors that are associated with A Channel have odd-numbered designations; those associated with B Channel have even-numbered designations. This distinction does not apply to the B+ power supply, which is common to both channels.

The input signal is applied at the input jack and across the LEVEL control, R1. The wiper of control R1 picks off the desired amount of signal. This signal is then applied through C1, R3 and R5 to the control grid of V1A. After being amplified in V1A, the signal is applied through C5 to the grid of V1B.

Triode V1B does not amplify the signal; instead, it serves as a phase splitter. The signals on the plate and cathode of V1B are equal in amplitude but are 180 degrees out-of-phase. These signals are applied to the control grids of output tubes V5 and V3 through coupling capacitors C7 and C9 respectively.

The push-pull output stage is operated in class AB1. The screen grids of the output tubes are connected to taps on the primary winding of the special-design output transformer. This type of operation provides greater power than triode operation and less distortion than pentode operation.

A phase reversal circuit follows the A Channel output transformer. This circuit consists of a double-pole-double-throw switch which is used to reverse the output transformer connections to the A Channel output speaker terminals.

Note that the 8 Ω output transformer tap, instead of the common tap, is connected to ground. This makes possible the CENTER SPEAKER connection, which will be described shortly.

Negative feedback is taken from the common end of the output transformer secondary. It is applied through a voltage divider consisting of R39 and

R11, to the cathode of V1A. Cathode bias for V1A is provided by the series combination of R9 and R11. R9 is bypassed by C3 in order to obtain high voltage gain from V1A. The feedback voltage applied across R11 acts in series opposition with the input voltage applied between the grid of V1A and ground. Capacitor C19, in conjunction with R39, produces a corrective phase shift in the feedback voltage at very high frequencies (beyond the audio range). Without the capacitor, the feedback voltage would turn somewhat positive at these frequencies, resulting in instability, i.e., "ringing," or even oscillation.

Except for the phase reversal circuit, A Channel is identical to B Channel.

The common tap of the A Channel output transformer is used with the 32 Ω tap of the B Channel output transformer to provide a CENTER SPEAKER output. The level of the signal at the CENTER SPEAKER output is proportional to the instantaneous sum of the A and B Channel output signals; therefore it is maximum when A and B signals are in-phase and is zero if A and B signals happen to be 180 degrees out-of-phase. This output may be loaded with either 4, 8 or 16 ohms.

The combined power of A and B Channels can be used to drive a single monophonic speaker. For this type of operation the monophonic speaker load should be connected to the SPKR terminals on the A Channel speaker output terminal strip. The COM terminal of the B Channel output should be connected to the "C" terminal of the A Channel output with a jumper wire.

If the monophonic speaker load is 16 ohms, a second jumper wire should be connected between the 32 Ω terminals of the A and B Channel outputs. For an 8 Ω load, connect the jumper wire between the 16 Ω terminals of the two outputs; for a 4 Ω load, connect the jumper wire between the 8 Ω terminals.

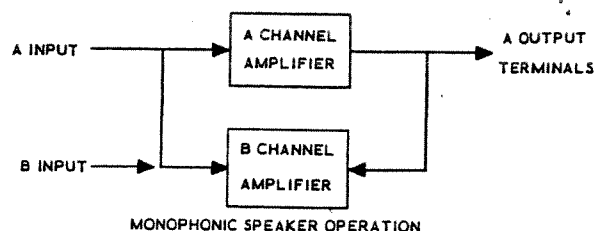

For monophonic speaker operation, the PHASE SELECTOR switch must be in the NORMAL position; the FUNCTION SELECTOR switch should be in the MON position. More information on this type of operation is included in the INSTALLATION AND OPERATION section of this manual.

The FUNCTION SELECTOR switch provides either Monophonic or Stereo operation, depending on its position, as shown in the following diagrams. Electrically, the connections for the FUNCTION SELECTOR switch are located between the input LEVEL control and the control grid of the input tube stage in each channel.

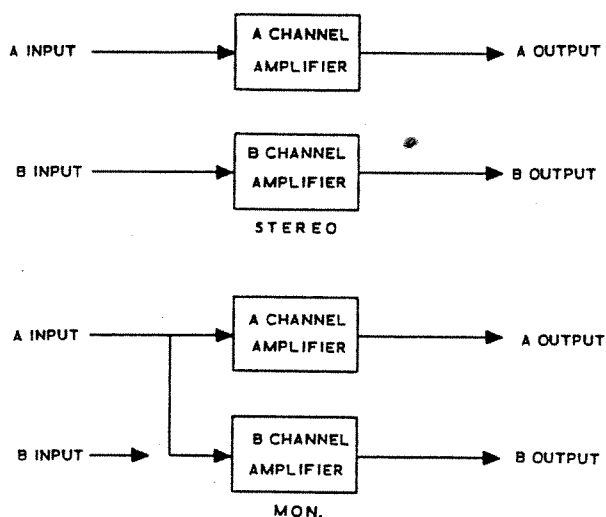

The bias power supply furnishes negative DC bias voltage which is applied to the grids of the output tubes. This voltage is adjustable by means of BALANCE control R53, for equal plate currents in V3 and V5. It is adjustable by means of VOLTAGE control R63 for proper magnitudes of plate current in these two tubes. The precision resistors R33 and R35, in the cathodes of V5 and V3, permit determination of balance and proper plate current, using only a voltmeter. Each cathode is brought out to a pin jack on the rear chassis apron, for convenient connection of the voltmeter. Balance is obtained by connecting the meter to the two pin jacks and adjusting the BALANCE control for zero meter indication; in other words, for equal voltages across R33 and R35, which means equal plate currents in V3 and V5. The bias voltage is then properly set by connecting the meter between ground (chassis) and either cathode (i.e., either pin jack) and adjusting the VOLTAGE control until the meter reads 1.5 volts.

The bias voltage applied to the adjustment controls is obtained from a 45 volt winding on the power transformer. This is rectified by selenium diode D1 and filtered by capacitor C29.

Silicon diodes D2, D3, D4 and D5 are used in a voltage doubler arrangement in the B+ power supply. The B+ voltage is heavily filtered in the power supply before it is applied to the tube stages in A and B Channels.

The pilot lamp is operated by B+ voltage. Current through the neon pilot lamp is limited to the correct value by R47.

The power transformer has separate filament windings for the A and B Channels. The A Channel filament winding is balanced to ground by R41 and R43. The B Channel filament winding is balanced to ground by R42 and R44. This balance to ground of filament voltage results in lower 60 cycle hum than would otherwise be obtained.

The power supply features an AC SWITCHED outlet and an AC NORMAL outlet. These outlets can be used to furnish AC power to associated equipment. The AC NORMAL outlet is in parallel with the line cord and therefore is turned on when the line cord is plugged into an AC power source. The AC SWITCHED outlet is controlled by the amplifier AC power switch. The AC outlets are not fused.

A 4 ampere slow-blow fuse is in series with the primary winding of the power transformer and protects the amplifier.

The surgistor, of which R50 is a part, is a protective device which eliminates surge current when the amplifier is turned on, thus prolonging the life of tubes and filter capacitors. The surgistor does this by acting as a resistor and thus limiting current when it is in a cold state. As current continues to flow it heats up, causing the bi-metal blade, attached to one end of the resistor, to gradually bend until it touches a contact at the other end of the resistor. At the instant of contact, the resistor becomes short-circuited by the blade, and is no longer in the circuit. Normal current now, via the blade, flows and the surgistor almost returns to its original cold state except that now current through the blade maintains it at a temperature such that the contacts remain closed.

A common ground circuit, or "bus," is used in the amplifier to provide a minimum hum level. This circuit is connected to the chassis only at the ground terminals of the input jacks.

25-224



CONSTRUCTION NOTES

This manual is supplied to assist you in every way to complete your kit with the least possible chance for error. The arrangement shown is the result of extensive experimentation and trial. If followed carefully, the result will be highly stable and dependable performance. We suggest that you retain the manual in your files for future reference, both in the use of the equipment and for its maintenance.

UNPACK THE KIT CAREFULLY AND CHECK EACH PART AGAINST THE PARTS LIST. In so doing, you will become acquainted with the parts. Refer to the information on the inside covers of the manual to help you identify the components. If some shortage or parts damage is found in checking the Parts List, please read the Replacements section and supply the information called for therein. Include all inspection slips in your letter to us.

Resistors generally have a tolerance rating of 10% unless otherwise stated in the Parts List. Tolerances on capacitors are generally even greater. Limits of +100% and -20% are common for electrolytic capacitors.

We suggest that you do the following before work is started:

1. Lay out all parts so that they are readily available.
2. Provide yourself with good quality tools. Basic tool requirements consist of a screwdriver with a 1/4" blade; a small screwdriver with a 1/8" blade; long-nose pliers; wire cutters, preferably separate diagonal cutters; a penknife or a tool for stripping insulation from wires; a soldering iron (or gun) and rosin core solder. A set of nut drivers and a nut starter, while not necessary, will aid extensively in construction of the kit.

Most kit builders find it helpful to separate the various parts into convenient categories. Muffin tins or molded egg cartons make convenient trays for small parts. Resistors and capacitors may be placed with their lead ends inserted in the edge of a piece of corrugated cardboard until they are needed. Values can be written on the cardboard next to each component. The illustration shows one method that may be used.

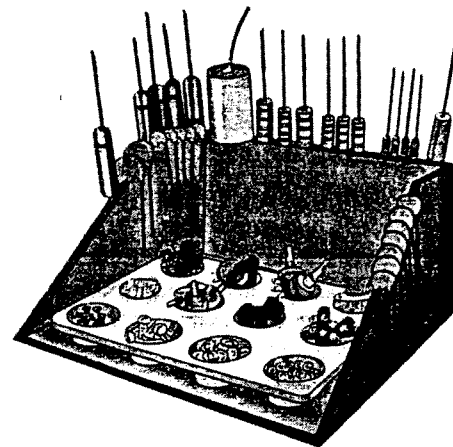

PARTS LIST

<u>PART No.</u>	<u>PARTS Per Kit</u>	<u>DESCRIPTION</u>	<u>PART No.</u>	<u>PARTS Per Kit</u>	<u>DESCRIPTION</u>
<u>Resistors</u>			<u>Capacitors</u>		
1-7	2	680 Ω 1/2 watt (blue-gray-brown)	20-35	2	910 μμf, mica (.00091 μfd)
1-13	2	2700 Ω 1/2 watt (red-violet-red)	20-108	4	200 μμf, mica
1-22	8	22 KΩ 1/2 watt (red-red-orange)	21-48	2	.05 μfd, disc
1-24	2	33 KΩ 1/2 watt (orange-orange-orange)	23-45	4	.047 μfd 600 V, tubular
1-25	2	47 KΩ 1/2 watt (yellow-violet-orange)	23-53	2	.1 μfd 400 V, tubular
1-26	2	100 KΩ 1/2 watt (brown-black-yellow)	23-59	2	.05 μfd 200 V, tubular
1-29	4	220 KΩ 1/2 watt (red-red-yellow)	25-16	1	20 μfd 350 V, electrolytic
1-31	2	330 KΩ 1/2 watt (orange-orange-yellow)	25-19	1	20 μfd 150 V, electrolytic
1-33	1	470 KΩ 1/2 watt (yellow-violet-yellow)	25-28	4	100 μfd 50 V, electrolytic
1-35	4	1 megohm 1/2 watt (brown-black-green)	25-33	1	20 μfd 450 V, electrolytic
1-60	2	68 KΩ 1/2 watt (blue-gray-orange)	25-50	2	150 μfd 300 V, electrolytic
1-68	1	820 KΩ 1/2 watt (gray-red-yellow)	25-51	2	200 μfd 300 V, electrolytic
1-73	4	8200 Ω 1/2 watt (gray-red-red)	25-98	2	50 μfd 15 V, electrolytic
1-89	2	2400 Ω 1/2 watt (red-yellow-red-gold) 5%	<u>Controls-Switches</u>		
1-105	4	10 KΩ 1/2 watt (brown-black-orange-gold) 5%	10-43	4	100 KΩ control
1-123	2	100 Ω 1/2 watt (brown-black-brown-gold) 5%	10-74	1	500 KΩ control
1A-5	4	22 KΩ 1 watt (matched) (red-red-orange)	19-52	1	500 KΩ control with AC switch and cover
1A-15	2	47 Ω 1 watt (yellow-violet-black)	60-2	1	Slide switch, DPDT
1B-3	1	10 KΩ 2 watt (brown-black-orange)	60-4	1	Slide switch, SPDT
1B-24	2	100 KΩ 2 watt (brown-black-yellow)	<u>Transformers-Diodes</u>		
2-100	2	12 Ω 1/2 watt, 1%	51-59	2	Output transformer
2-107	4	6 Ω 1/2 watt, 1%	54-102	1	Power transformer
9-3	1	Surgistor, 100 to 300 watts	57-20	4	Silicon diode
			57-22	1	Selenium diode
			<u>Grommets-Wire-Sleeving</u>		
			73-4	1	Rubber grommet
			89-1	1	Line cord
			340-1	1	Length heavy bare wire
			343-3	1	Length 1-conductor shielded cable
			344-1	3	Lengths hookup wire, 1 each: green, yellow and orange
			344-2	1	Length stranded hookup wire
			346-1	1	Length insulating sleeving
			347-3	1	Length 2-conductor shielded cable
			<u>Tubes</u>		
			411-68	2	6AN8
			411-112	4	EL34/6CA7



<u>PART No.</u>	<u>PARTS Per Kit</u>	<u>DESCRIPTION</u>
<u>Hardware</u>		
250-8	4	#6 x 3/8" sheet metal screw
250-49	4	3-48 x 1/4" screw
250-52	8	4-40 x 1/4" screw
250-56	47	6-32 x 1/4" screw
250-89	9	6-32 x 3/8" screw
250-170	6	#6 x 1/4" sheet metal screw
252-1	4	3-48 nut
252-2	8	4-40 nut
252-3	56	6-32 nut
252-4	12	8-32 nut
252-7	7	Control nut
252-20	4	Plastic cap nut
252-32	1	Speednut, large
253-10	6	Control flat washer
254-1	73	#6 lockwasher
254-2	12	#8 lockwasher
254-4	6	Control lockwasher
254-7	4	#3 lockwasher
254-9	8	#4 lockwasher
259-1	1	#6 solder lug
259-11	5	#6 spade lug
260-11	4	Spring catch clip
262-4	4	Spring catch pin

Terminal Strips-Sockets

431-2	2	2-lug terminal strip
431-3	2	3-lug terminal strip
431-6	1	2-lug screw terminal strip
431-7	1	6-lug screw terminal strip

<u>PART No.</u>	<u>PARTS Per Kit</u>	<u>DESCRIPTION</u>
<u>Terminal Strips-Sockets (cont'd.)</u>		
431-15	6	1-lug terminal strip
431-17	1	5-lug screw terminal strip
431-18	2	2-lug pin jack
431-19	1	5-lug upright terminal strip
431-20	3	6-lug upright terminal strip
431-26	2	1-lug terminal strip
431-28	4	4-lug vertical terminal strip
434-16	2	9-pin tube socket
434-20	2	AC socket
434-58	4	Octal tube socket
434-82	1	Double phono jack
481-3	4	Capacitor mounting wafer

Metal Parts

90-189	1	Top cover
200-M259F351-574-575		
	1	Chassis
205-M218	1	Bottom plate

Miscellaneous

75-24	1	Line cord strain relief
261-11	4	Plastic feet
412-12	1	Pilot lamp
421-5	1	Fuse, 4 ampere slow-blow
423-1	1	Fuse holder with hardware
462-17	2	Pointer knob
331-6		Solder
595-468	1	Manual

PROPER SOLDERING TECHNIQUES

Only a small percentage of HEATHKIT equipment purchasers find it necessary to return an instrument for factory service. Of these instruments, by far the largest portion malfunction due to poor or improper soldering.

If terminals are bright and clean and free of wax, frayed insulation and other foreign substances, no difficulty will be experienced in soldering. Correctly soldered connections are essential if the performance engineered into a kit is to be fully realized. If you are a beginner with no experience in soldering, a half hour's practice with some odd lengths of wire may be a worthwhile investment.

For most wiring, a 30 to 100 watt iron or its equivalent in a soldering gun is very satisfactory. A lower wattage iron than this may not heat the connection enough to flow the solder smoothly over the joint. Keep the iron tip clean and bright by wiping it from time to time with a cloth.

CHASSIS WIRING AND SOLDERING

1. Unless otherwise indicated, all wire used is the type with colored insulation (hookup wire); the size of the conductor is the same for all colors of hookup wires furnished with this kit. In preparing a length of hookup wire, 1/4" of insulation should be removed from each end unless directed otherwise in the construction step.

2. To avoid breaking internal connections when stripping insulation from the leads of transformers or similar components, care should be taken not to pull directly on the lead. Instead, hold the lead with pliers while it is being stripped.
3. Leads on resistors, capacitors and similar components are generally much longer than they need to be to make the required connections. In these cases, the leads should be cut to proper length before the part is added to the chassis. In general, the leads should be just long enough to reach their terminating points.
4. Wherever there is a possibility of bare leads shorting to other parts or to the chassis, the leads should be covered with insulating sleeving. Where the use of sleeving is specifically intended, the phrase "use sleeving" is included in the associated construction step. In any case where there is the possibility of an unintentional short circuit, sleeving should be used. Extra sleeving is provided for this purpose.
5. Crimp or bend the lead (or leads) around the terminal to form a good joint without relying on solder for physical strength. If the wire is too large to allow bending or if

the step states that the wire is not to be crimped, position the wire so that a good solder connection can still be made.

6. Position the work, if possible, so that gravity will help to keep the solder where you want it.
7. Place a flat side of the soldering iron tip against the joint to be soldered until it is heated sufficiently to melt the solder.
8. Then place the solder against the heated terminal and it will immediately flow over the joint; use only enough solder to thoroughly wet the junction. It is usually not necessary to fill the entire hole in the terminal with solder.
9. Remove the solder and then the iron from the completed junction. Use care not to move the leads until the solder is solidified.

A poor or cold solder joint will usually look crystalline and have a grainy texture, or the solder will stand up in a blob and will not have adhered to the joint. Such joints should be reheated until the solder flows smoothly over the entire junction. In some cases, it may be necessary to add a little more solder to achieve a smooth bright appearance.

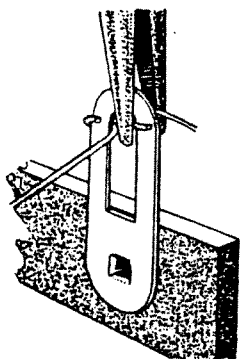

CRIMP WIRES

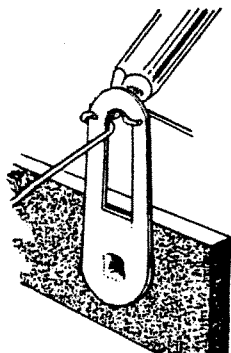

HEAT CONNECTION

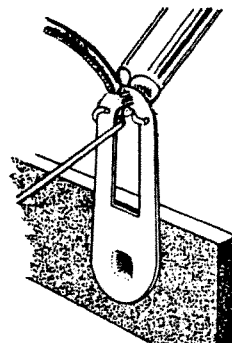

APPLY SOLDER

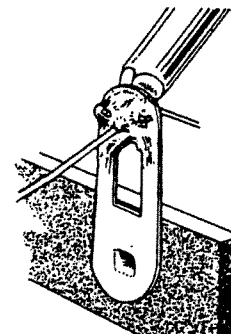

ALLOW SOLDER TO FLOW

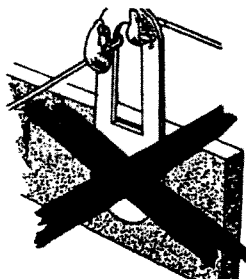

COLD SOLDER JOINT CONNECTION INSUFFICIENTLY HEATED

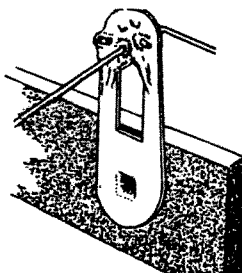

PROPER SOLDER CONNECTION

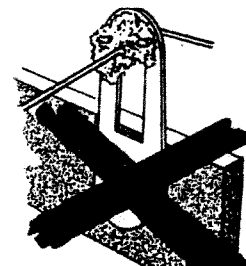

COLD SOLDER JOINT CONNECTION MOVED WHILE COOLING

ROSIN CORE SOLDER HAS BEEN SUPPLIED WITH THIS KIT. THIS TYPE OF SOLDER MUST BE USED FOR ALL SOLDERING IN THIS KIT. ALL GUARANTEES ARE VOIDED AND WE WILL NOT REPAIR OR SERVICE EQUIPMENT IN WHICH ACID CORE SOLDER OR PASTE FLUXES HAVE BEEN USED. IF ADDITIONAL SOLDER IS NEEDED, BE SURE TO PURCHASE ROSIN CORE (60:40 or 50:50 TIN-LEAD CONTENT) RADIO TYPE SOLDER.

STEP-BY-STEP PROCEDURE

The following instructions are presented in a logical step-by-step sequence to enable you to complete your kit with the least possible confusion. Be sure to read each step all the way through before beginning the specified operation. Also read several steps ahead of the actual step being performed. This will familiarize you with the relationship of the subsequent operations. When the step is completed, check it off in the space provided. This is particularly important as it may prevent errors or omissions, especially if your work is interrupted. Some kit builders have also found it helpful to mark each lead in colored pencil on the Pictorial as it is added.

The large folded diagrams may be removed from the manual and attached to the wall above your working area but should be returned to the manual after the kit is completed.

In general, the illustrations in this manual correspond to the actual configuration of the kit; however, in some instances the illustrations may be slightly distorted to facilitate clearly showing all of the parts.

The abbreviation "NS" indicates that a connection should not be soldered yet as other wires will be added. When the last wire is installed, the terminal should be soldered and the abbreviation "S" is used to indicate this. Note that a number will appear after each solder instruction. This number indicates the number of leads that are supposed to be connected to the terminal in point before it is soldered. For example, if the instruction reads, "Connect a lead to lug 1 (S-2)," it will be understood that there will be two leads connected to the terminal at the time it is soldered. (In cases where a lead passes through a terminal or lug and then connects to another point, it will count as two leads, one entering and one leaving the terminal.)

The steps directing the installation of resistors and some capacitors include color codes to help identify the parts. Also, if a part is identified by a letter-number designation on the Schematic, its designation will appear in the construction step which directs its installation.

STEP-BY-STEP ASSEMBLY

Mechanical Assembly

Refer to Pictorial 1 (fold-out from Page 17) for the following steps.

- () Mount spring catch clip TT in the lower left corner of the chassis. Use 4-40 screws, #4 lockwashers and 4-40 nuts as shown in Detail 1A.
- () Similarly, mount spring catch clips UU, VV and WW.

NOTE: The phrase "#6 hardware" means 6-32 x 1/4" screws, #6 lockwashers and 6-32 nuts. The 6-32 x 3/8" screws should be used only when specifically called for.

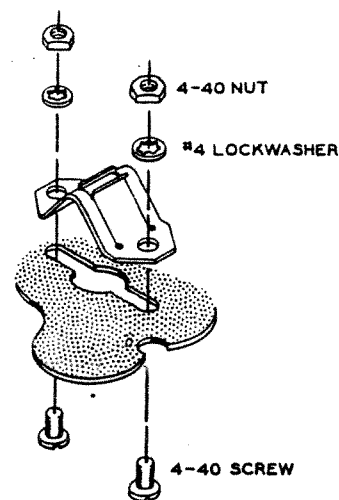

Detail 1A

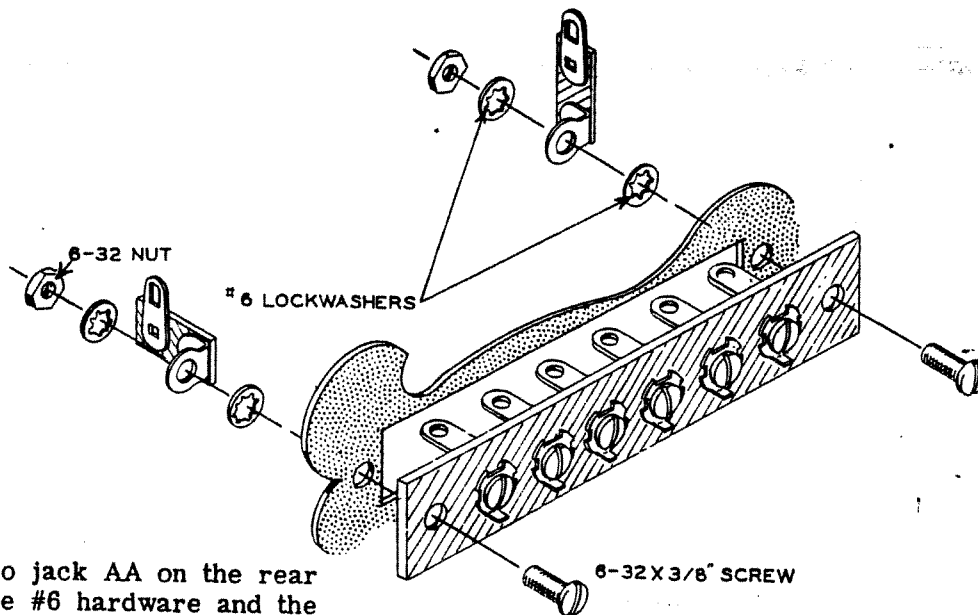

Detail 1B

- () Mount double phono jack AA on the rear chassis flange. Use #6 hardware and the #6 solder lug as shown in Pictorial 1.
- () Install the grommet in hole GG.
- () From the outside of the rear chassis flange, mount 6-lug screw terminal strip DD, single-lug terminal strip CC and single-lug terminal strip EE. Use 6-32 x 3/8" screws, #6 lockwashers and 6-32 nuts as shown in Detail 1B.

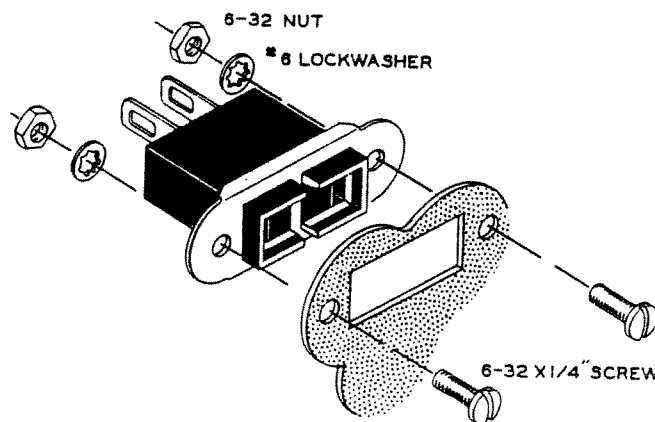

Detail 1C

- () From the outside of the rear chassis flange, mount 5-lug screw terminal strip LL, single-lug terminal strip KK and single-lug terminal strip MM. Use 6-32 x 3/8" screws, #6 lockwashers and 6-32 nuts.
- () From the outside of the rear chassis flange, mount 2-lug screw terminal strip HH with #6 hardware.
- () From the outside of the rear chassis flange, mount pin jacks FF and PP. Use #6 hardware.

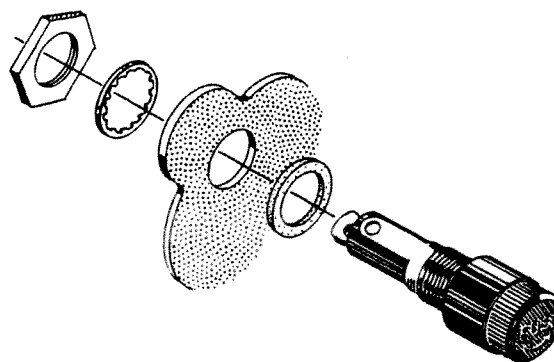

Detail 1D

- () From the inside of the rear chassis flange, mount AC sockets NN and SS with #6 hardware. Refer to Detail 1C.
- () Mount 6-lug slide switch BB with 6-32 x 1/4" screws. Lockwashers and nuts are not needed.
- () Referring to Detail 1D, mount fuse holder JJ. Use the hardware that is furnished with it. After the fuse holder has been secured in place, bend the lug on the side outward as shown in Pictorial 1.

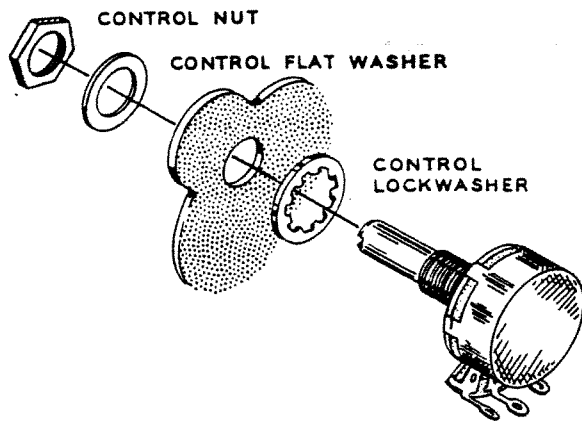

Detail 1E

- () R53, 63, 64 and 54. Mount 100 K Ω controls (#10-43) V, W, X and Y, on the front chassis flange. Refer to Detail 1E.
- () R1. Mount control U (#19-52). Note that this control has the AC OFF-ON switch as its rear section.
- () R2. Similarly, mount control Z (#10-74). Place a control nut and control lockwasher on the control bushing before mounting. This extra nut will properly space the length of the control shaft outside of the front chassis apron.
- () Using the large push-on speednut, install pilot lamp YY. Make sure that the speednut is pushed far enough onto the pilot lamp to hold it securely in place.
- () Mount 3-lug slide switch XX with 6-32 x 1/4" screws. Lockwashers and nuts are not needed. Orientation of this switch is not important.

NOTE: When installing tube sockets in the following steps, make sure that the blank spaces of the 9-pin sockets and the keyways of the octal sockets are oriented as indicated by the arrows in Pictorial 1. Also, be sure that the sockets are installed inside of the chassis, as shown.

- () Referring to Detail 1F, mount 9-pin tube socket V1. Use 3-48 screws, #3 lockwashers and 3-48 nuts.
- () Similarly, mount 9-pin tube socket V2.

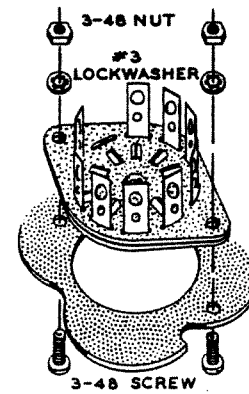

Detail 1F

- () Referring to Detail 1G, mount octal tube socket V3, single-lug terminal strip D and 4-lug terminal strip E. Use #6 hardware. Note that a lockwasher is used between the mounting foot of each terminal strip and the tube socket.
- () Similarly, mount octal tube socket V5 and single-lug terminal strip F.
- () Mount octal tube socket V4, single-lug terminal strip M and 4-lug terminal strip N.
- () Mount octal tube socket V6 and single-lug terminal strip P.

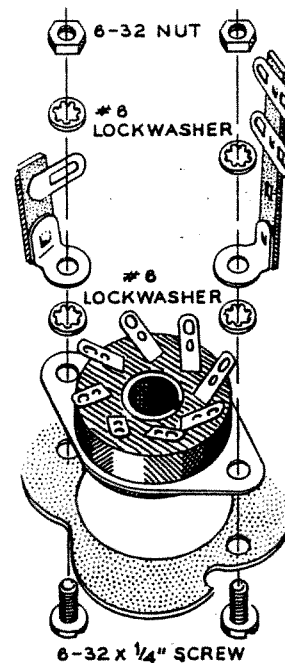

Detail 1G

- () Referring to Detail 1H, mount 3-lug terminal strip C. Use #6 hardware. Note the lockwasher between the terminal strip mounting foot and the chassis.
- () Similarly, mount terminal strips B, J and L.
- () Mount a 4-lug terminal strip at QQ.

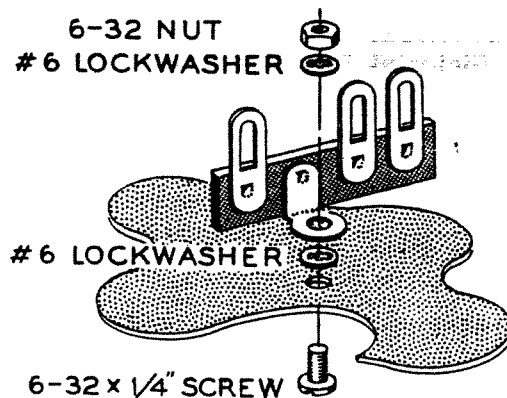

Detail 1H

- () Using #6 hardware, mount upright terminal strips A, G, H and K. Refer to Detail 1J.
- () R50. Adjust the surgistor (#9-3) so that the opening between the points is equal to two thicknesses of the material of the surgistor carton. Now, mount the surgistor at RR with #6 hardware, being careful not to disturb its adjustment. Place an extra #6 lockwasher between the surgistor mounting foot and the chassis.

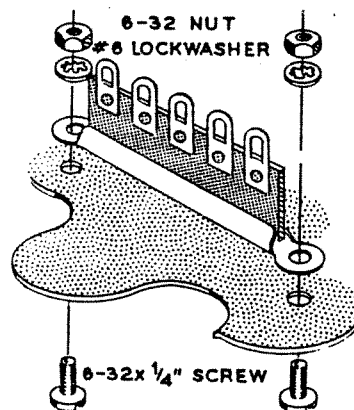

Detail 1J

- () Install a capacitor mounting wafer at Q with #6 hardware as shown in Detail 1K. Make sure that the wafer is mounted on top of the chassis.
- () Similarly, install capacitor mounting wafers at R and S.
- () Install 4-lug terminal strip I and the remaining capacitor mounting wafer at T. Use #6 hardware with an extra #6 lockwasher between the terminal strip mounting foot and the chassis. A 6-32 x 3/8" screw is used to mount the terminal strip.
- () C27 and 28. Install the two 150 μfd can-type electrolytic capacitors in the capacitor mounting wafers at S and T. Orient the terminal of each capacitor as shown in Pictorial 1. Secure these capacitors in place by twisting their mounting lugs 1/8 turn with long-nose pliers.
- () C25 and 26. Similarly, install the two 200 μfd can-type electrolytic capacitors at Q and R.

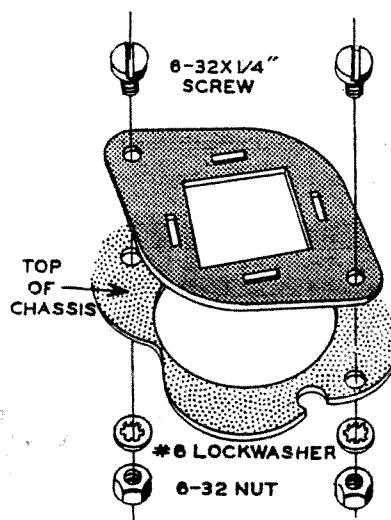

Detail 1K

NOTE: When preparing and installing the power and output transformers in the following steps, refer to Pictorial 1 to distinguish between the primary and secondary leads.

Cut the leads of the power transformer (#54-102) to the following lengths:

<u>Lead Color</u>	<u>Length</u>
Primary	
() Either black	5"
() Other black	4"

Secondary	
() Both blue	1-1/2"
() Both green	1-1/2"
() Either red	1-1/2"
() Other red	3"
() Either gray	8"
() Other gray	6"
() Strip 1/4" of insulation from the end of each power transformer lead and tin. ("Tin" means melt a small amount of solder over the exposed wire end.) If your transformers have pretinned leads, this will not be necessary. The strands of pretinned leads are lightly soldered together.	

() Mount the power transformer in the center chassis cutout. The two black leads should be toward the rear chassis flange. Secure the transformer in place with #8 lockwashers and 8-32 nuts.

Cut the leads of one of the output transformers (#51-59) to the following lengths:

<u>Lead Color</u>	<u>Length</u>
Primary	
() Blue	2-1/4"
() Green	2-1/4"
() Blue-yellow	2-3/4"
() Green-yellow	2-3/4"
() Red	8"

- Secondary**
- () Black 2"
 - () Brown 3"
 - () Orange 2-1/2"
 - () Yellow 2"
 - () Green 1-3/4"
- () Strip 1/4" of insulation from the end of each lead and tin.
- () Using #8 lockwashers and 8-32 nuts, install this transformer in the left (A Channel) chassis cutout. The black, brown, orange, yellow and green leads should be toward the rear chassis flange.

Cut the leads of the second output transformer to the following lengths:

<u>Lead Color</u>	<u>Length</u>
Primary	
() Blue	2-1/4"
() Green	2-1/4"
() Blue-yellow	2-3/4"
() Green-yellow	2-3/4"
() Red	6"

- Secondary**
- () Black 1-3/4"
 - () Brown 1-1/2"
 - () Orange 1-1/2"
 - () Yellow 1-1/2"
 - () Green 1-3/4"
- () Strip 1/4" of insulation from the end of each lead and tin.

() Install this transformer in the right (B Channel) chassis cutout with #8 lockwashers and 8-32 nuts. The black, brown, orange, yellow and green leads should be toward the rear chassis flange.

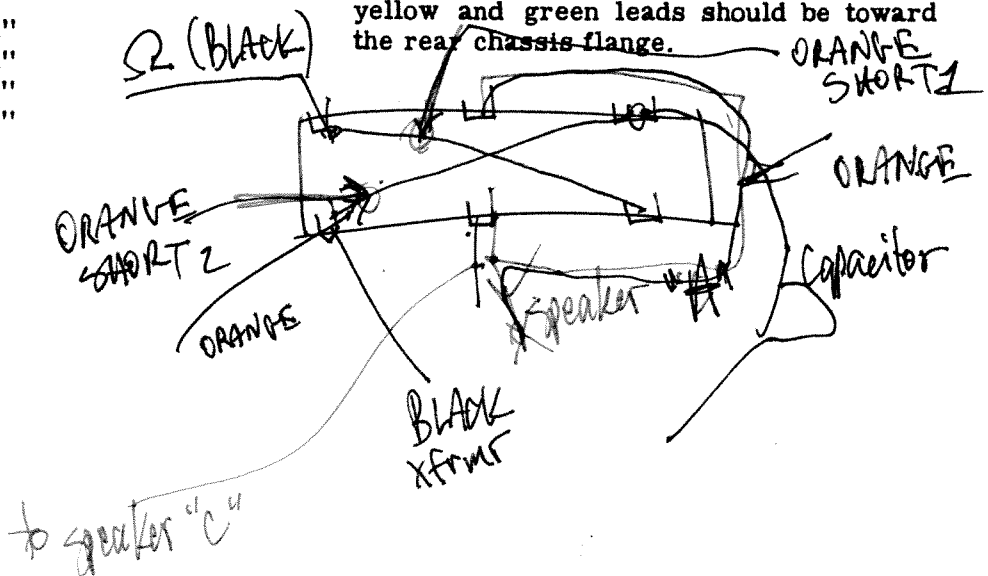

Initial Wiring

Refer to Pictorial 2 for the following steps.

Connect the power transformer leads as follows:

<u>Lead Color</u>	<u>Connect to</u>
Primary	
<input type="checkbox"/> Longer black	lug 1 of surgistor RR (S-1)
Note: If necessary, remove a few strands so lead will enter hole in lug of RR.	
<input type="checkbox"/> Shorter black	lug 1 of fuse holder JJ (S-1)
Secondary	
<input type="checkbox"/> Longer red	lug 1 of capacitor S (NS)
<input type="checkbox"/> Shorter red	lug 3 of terminal strip H (NS)
<input type="checkbox"/> Either green	lug 1 of terminal strip H (NS)
<input type="checkbox"/> Other green	lug 2 of terminal strip H (NS)
<input type="checkbox"/> Either blue	lug 5 of terminal strip H (NS)
<input type="checkbox"/> Other blue	lug 6 of terminal strip H (NS)
<input type="checkbox"/> Twist the two gray power transformer leads together, then connect the shorter lead to lug 3 of capacitor Q (S-1) and the longer lead to lug 3 of terminal strip G (NS).	

Connect the A Channel output transformer leads as follows:

<u>Lead Color</u>	<u>Connect to</u>
Primary	
<input type="checkbox"/> Red	lug 1 of capacitor T (NS)
<input type="checkbox"/> Blue-yellow	lug 3 of socket V3 (S-1)
<input type="checkbox"/> Green-yellow	lug 4 of socket V3 (S-1)
<input type="checkbox"/> Blue	lug 3 of socket V5 (S-1)
<input type="checkbox"/> Green	lug 4 of socket V5 (S-1)
Secondary	
<input type="checkbox"/> Green	lug 3 of terminal strip DD (S-1)
<input type="checkbox"/> Yellow	lug 4 of terminal strip DD (NS)
<input type="checkbox"/> Orange	lug 5 of terminal strip DD (NS)
<input type="checkbox"/> Brown	lug 6 of terminal strip DD (S-1)
<input type="checkbox"/> Black	lug 6 of switch BB (NS)

Connect the B Channel output transformer leads as follows:

<u>Lead Color</u>	<u>Connect to</u>
Primary	
<input type="checkbox"/> Red	lug 1 of capacitor T (NS)
<input type="checkbox"/> Blue-yellow	lug 3 of socket V4 (S-1)
<input type="checkbox"/> Green-yellow	lug 4 of socket V4 (S-1)
<input type="checkbox"/> Blue	lug 3 of socket V6 (S-1)
<input type="checkbox"/> Green	lug 4 of socket V6 (S-1)
Secondary	
<input type="checkbox"/> Green	lug 1 of terminal strip LL (NS)
<input type="checkbox"/> Yellow	lug 2 of terminal strip LL (NS)
<input type="checkbox"/> Orange	lug 3 of terminal strip LL (NS)
<input type="checkbox"/> Brown	lug 4 of terminal strip LL (S-1)
<input type="checkbox"/> Black	lug 5 of terminal strip LL (NS)

NOTE: The purpose of using twisted pairs of hookup wire is to provide cancellation of hum in the filament leads. Best results will be obtained in the following steps if the wires are twisted approximately two complete turns per inch. The wires may be twisted by hand or with a drill, as shown in Detail 2A. If a drill is used, be careful not to twist the wires too tightly.

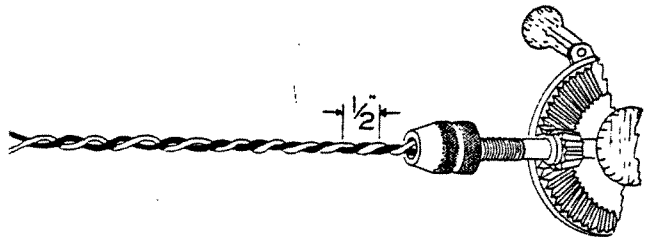

Detail 2A

Locate the green and yellow lengths of hookup wire. Twist these two wires together using either method mentioned in the preceding NOTE.

NOTE: When preparing lengths of twisted hookup wires, unwind only enough wire at each end to reach the terminating points called out in the steps. Strip 1/4" of insulation from both ends of each wire, then make the connections that are directed in the steps. Dress the twisted wires against the chassis and under the transformer leads which are already connected.

- () At one end of a 5-1/4" twisted pair, connect the green wire to lug 5 (S-1) and the yellow wire to lug 4 (S-1) of tube socket V1.
- () At the other end, connect the green wire to lug 7 (NS) and the yellow wire to lug 2 (NS) of tube socket V3.
- () At one end of a 5" twisted pair, connect the green wire to lug 7 (S-2) and the yellow wire to lug 2 (S-2) of tube socket V3.
- () At the other end, connect the green wire to lug 7 (NS) and the yellow wire to lug 2 (NS) of tube socket V5.
- () At one end of a 4-1/2" twisted pair connect the green wire to lug 7 (S-2) and the yellow wire to lug 2 (S-2) of tube socket V5.
- () At the other end, connect the green wire to lug 1 (NS) and the yellow wire to lug 2 (NS) of terminal strip H.
- () At one end of a 6" twisted pair, connect the green wire to lug 5 (NS) and the yellow wire to lug 6 (NS) of terminal strip H.
- () At the other end, connect the green wire to lug 7 (NS) and the yellow wire to lug 2 (NS) of tube socket V4.
- () At one end of a 4-1/2" twisted pair, connect the green wire to lug 7 (NS) and the yellow wire to lug 2 (NS) of tube socket V4.
- () At the other end, connect the green wire to lug 7 (S-1) and the yellow wire to lug 2 (S-1) of tube socket V6.
- () At one end of a 5-1/2" twisted pair, connect the green wire to lug 7 (S-3) and the yellow wire to lug 2 (S-3) of tube socket V4.
- () At the other end, connect the green wire to lug 5 (S-1) and the yellow wire to lug 4 (S-1) of tube socket V2.

Refer to Pictorial 3 (fold-out from Page 25) for the following steps.

- () Referring to Detail 3A, bend the two center lugs of switch BB outward as shown. This will provide additional space between the switch lugs and thereby minimize the possibility of short circuits in the wiring of this switch.

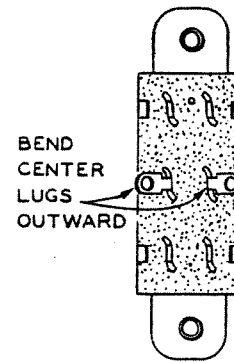

Detail 3A

NOTE: Use the orange hookup wire in the following steps. Dress the hookup wires against the chassis and under the transformer leads which are already connected.

- () Strip 3/4" of insulation from one end and 1/4" from the other end of a 2" wire. Connect the 3/4" stripped end through lug 4 (NS) to lug 5 (S-1) of phono jack AA.
- () Connect the other end of this wire to lug 1 of phono jack AA (NS).
- () Connect a 1-1/4" wire from lug 2 of terminal strip DD (S-1) to lug 5 of switch BB (S-1).
- () Connect a 2-3/4" wire from lug 1 of terminal strip DD (S-1) to lug 2 of switch BB (S-1).
- () Connect a 1" wire from lug 1 (NS) to lug 6 (NS) of switch BB.
- () Connect another 1" wire from lug 4 (S-1) to lug 3 (NS) of switch BB.
- () Connect a 5" wire from lug 6 of switch BB (S-3) to lug 1 of terminal strip HH (NS).
- () Connect a 6" wire from lug 2 of terminal strip HH (S-1) to lug 1 of terminal strip LL (S-2).
- () Connect a 1-1/2" wire from lug 2 of AC socket SS (NS) to lug 2 of fuse holder JJ (S-1).
- () Connect a 1-1/2" wire from lug 2 of AC socket NN (NS) to lug 2 of AC socket SS (S-2).
- () Connect an 8-1/4" wire from lug 2 of surge resistor RR (S-1) to lug 1 of AC socket SS (NS).
- () Connect a 9" wire from lug 5 of terminal strip DD (S-2) to lug 3 of terminal strip E (NS).

- () Strip 1/2" of insulation from one end and 1/4" from the other end of an 11" wire. Connect the 1/2" stripped end through lug 1 (NS) to lug 8 (NS) of tube socket V3. Now solder lug 1 (S-2).
- () Connect the other end of this wire to lug 1 of pin jack FF (S-1).
- () Strip 1/2" of insulation from one end and 1/4" from the other end of an 8" wire. Connect the 1/2" stripped end through lug 1 (NS) to lug 8 (NS) of tube socket V5. Now solder lug 1 (S-2).
- () Connect the other end of this wire to lug 2 of pin jack FF (S-1).
- () Connect a 13-1/2" wire from the lug of terminal strip EE (NS) to lug 4 of terminal strip A (NS).
- () Strip 1/2" of insulation from one end and 1/4" from the other end of a 9" wire. Connect the 1/2" stripped end through lug 1 (NS) to lug 8 (NS) of tube socket V4. Now solder lug 1 (S-2).
- () Connect the other end of this wire to lug 1 of pin jack PP (S-1).
- () Connect a 12-1/2" wire from the lug of terminal strip KK (NS) to lug 5 of terminal strip K (NS).
- () Connect a 9" wire from lug 3 of terminal strip LL (S-2) to lug 3 of terminal strip N (NS).
- () Strip 1/2" of insulation from one end and 1/4" from the other end of an 8-1/2" wire. Connect the 1/2" stripped end through lug 1 (NS) to lug 8 (NS) of tube socket V6. Now solder lug 1 (S-2).
- () Connect the other end of this wire to lug 2 of pin jack PP (S-1).
- () Connect a 2" wire from lug 1 of terminal strip QQ (S-1) to lug 1 of control U (NS).
- () Connect a 4-1/4" wire from lug 3 of terminal strip E (NS) to lug 2 of terminal strip C (NS).
- () Connect a 6-1/4" wire from the lug of terminal strip D (NS) to lug 1 of terminal strip B (NS).
- () Connect a 5-1/2" wire from the lug of terminal strip F (NS) to lug 2 of terminal strip B (NS).
- () Connect a 5" wire from lug 2 of terminal strip C (NS) to lug 2 of terminal strip A (NS).
- () Connect a 4-1/2" wire from lug 3 of terminal strip C (NS) to lug 1 of terminal strip A (NS).
- () Connect a 5" wire from lug 2 of terminal strip A (NS) to lug 1 of control U (NS).
- () Connect a 7" wire from lug 3 of terminal strip A (NS) to lug 1 of slide switch XX (S-1).
- () Connect a 7-1/4" wire from lug 1 of terminal strip A (NS) to lug 2 of terminal strip G (NS).
- () Connect an 11" wire from lug 7 of tube socket V1 (NS) to lug 7 of tube socket V2 (NS).
- () Connect a 8" wire from lug 2 of control V (S-1) to lug 6 of terminal strip G (NS).
- () Connect a 4" wire from lug 1 of control W (NS) to lug 1 of terminal strip G (NS).
- () Connect a 5-1/2" wire from lug 1 of control X (NS) to lug 1 of terminal strip G (NS).
- () Connect a 5-1/2" wire from lug 2 of control Y (S-1) to lug 6 of terminal strip G (NS).
- () Connect a 6-1/4" wire from lug 2 of terminal strip G (NS) to lug 1 of terminal strip K (NS).
- () Connect a 3-1/2" wire from lug 2 of terminal strip K (NS) to lug 1 of control Z (NS).
- () Connect a 6" wire from lug 3 of terminal strip K (NS) to lug 3 of slide switch XX (S-1).
- () Connect a 6-1/2" wire from lug 4 of terminal strip K (NS) to lug 2 of slide switch XX (S-1).
- () Connect a 4" wire from lug 2 of terminal strip K (NS) to lug 2 of terminal strip L (NS).

- () Connect a 5" wire from lug 1 of terminal strip K (NS) to lug 3 of terminal strip L (NS).
- () Connect a 4-1/4" wire from lug 2 of terminal strip L (NS) to lug 3 of terminal strip N (NS).
- () Connect a 5-1/2" wire from the lug of terminal strip P (NS) to lug 2 of terminal strip J (NS).
- () Connect a 4-1/2" wire from the lug of terminal strip M (NS) to lug 1 of terminal strip J (NS).
- () Connect a 2-3/4" wire from lug 6 of terminal strip G (NS) to lug 4 of capacitor Q (S-1).
- () Connect a 2-1/2" wire from lug 4 of capacitor R (S-1) to lug 1 of capacitor Q (NS).
- () Connect a 2-1/4" wire from lug 4 of terminal strip G (NS) to lug 1 of capacitor R (NS).
- () Connect a 3" wire from lug 1 of capacitor R (NS) to lug 1 of capacitor T (NS).
- () Connect a 1-1/4" wire from lug 2 of capacitor Q (NS) to lug 4 of capacitor S (S-1).
- () Connect a 2-1/4" wire from lug 1 of capacitor S (S-2) to lug 2 of capacitor T (S-1).
- () Connect a 2-3/4" wire from lug 1 of capacitor T (S-4) to lug 4 of terminal strip H (NS).
- () Connect one end of a 2-1/4" wire to lug 2 of capacitor S (S-1). Leave the other end free.

NOTE: The bus grounding circuit will be installed in the next step. The heavy bare wire is used in this circuit and will be referred to as "bus wire" throughout the remainder of the manual.

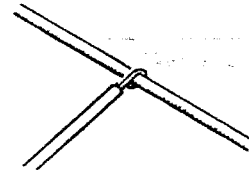

Detail 3B

- () Cut a 10-1/4" length of bus wire. Install this wire in a straight line from lug 3 of terminal strip E to lug 3 of terminal strip N. Use a small amount of solder at each of these lugs to "tack" the bus wire in place. Remember that other wires will later be connected to these lugs.
- () Connect the free end of the wire coming from lug 2 of capacitor S to the bus wire (NS). Make this connection directly above lug 3 of terminal strip H. Refer to Detail 3B.
- () Strip both ends of a 7-3/4" length of stranded hookup wire and connect one end to lug 3 of slide switch BB (S-2). Pass the other end through grommet GG to the outside of the rear chassis flange.
- () Locate a #6 spade lug. Crimp this spade lug on the free end of the stranded hookup wire that was just installed and solder the connection.
- () Temporarily secure the spade lug with the 32 Ω screw of terminal strip DD.

CAUTION: When preparing and installing shielded cable, avoid overheating the leads as excessive heat will melt the insulation and may cause a short circuit between the inner lead and the shield. A method of preparing shielded cable is shown in Detail 3C.

- () Cut a 10" length of 1-conductor shielded cable. At one end remove 1" of outer jacket. Unwind the shield and twist it into a pigtail. Then cut off 1/2" of inner insulated conductor. Now finish preparing the cable as shown in Detail 3D.

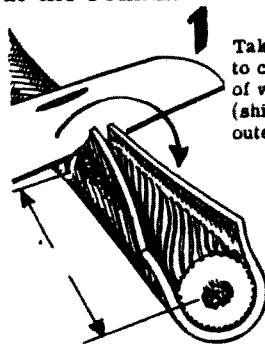

1 Taking care not to cut outer layer of very thin wires (shield) remove outer insulation.

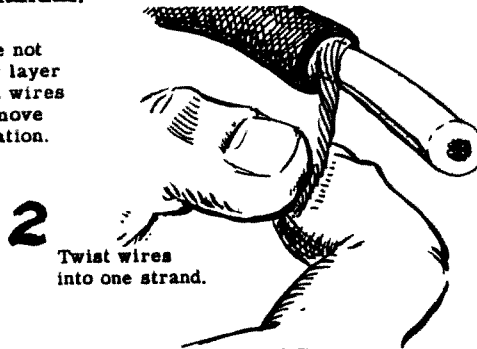

2 Twist wires into one strand.

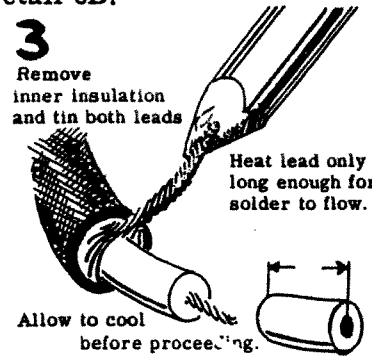

3 Remove inner insulation and tin both leads

Heat lead only long enough for solder to flow.

Allow to cool before proceeding.

Detail 3C

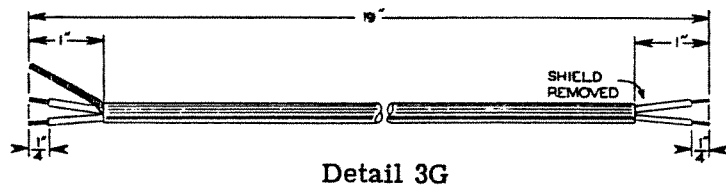
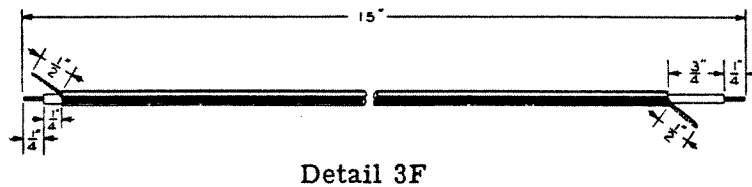
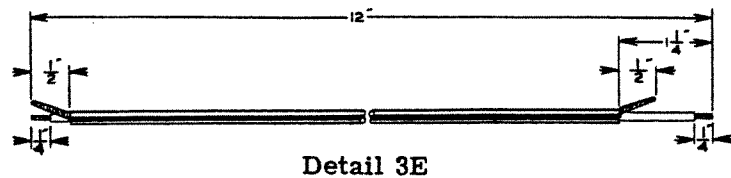
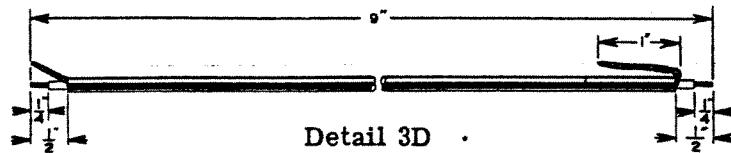

- () Connect the longer shield lead to lug 4 of phono jack AA (S-3).
- () Connect the inner lead at this end of the cable to lug 3 of phono jack AA (S-1).
- () At the other end of this cable, connect the inner lead to lug 4 (NS) and the shield lead to lug 3 (NS) of terminal strip QQ.
- () Prepare a length of 1-conductor shielded cable as indicated in Detail 3E.
- () Connect the longer inner lead to lug 3 of control U (S-1).
- () Connect the shield lead at this end of the cable to lug 1 of control U (S-3).
- () At the other end of this cable, connect the inner lead to lug 2 (S-1) and the shield lead to lug 1 (S-2) of phono jack AA.
- () Prepare a 1-conductor shielded cable as indicated in Detail 3F.
- () Connect the longer inner lead to lug 3 of control Z (S-1).
- () Connect the shield lead at this end of the cable to lug 1 of control Z (S-2).
- () Dress this cable along the front of the chassis. At the free end of the cable, connect the inner lead to lug 4 (S-2) and the shield lead to lug 3 (S-2) of terminal strip QQ.
- () Prepare a length of 2-conductor shielded cable as indicated in Detail 3G.
- () At the end of this cable without a shield lead, connect the yellow lead to lug 1 of AC socket NN (NS).
- () Connect the green lead at this end of the cable to lug 1 of AC socket SS (S-2).
- () Dress this cable around the lower left corner of the chassis and toward control U. The cable should be beneath the secondary leads of the A Channel output transformer.
- () Remove the AC switch cover from control U and slip it over the free ends of the green and yellow leads.
- () Connect the green lead of this cable to either lug on the rear of control U (S-1).
- () Connect the yellow lead to the other lug on the rear of control U (S-1).
- () Carefully place the AC switch cover over the rear section of control U, then solder the shield lead of the cable to the outside of the AC switch cover as shown in Pictorial 3.

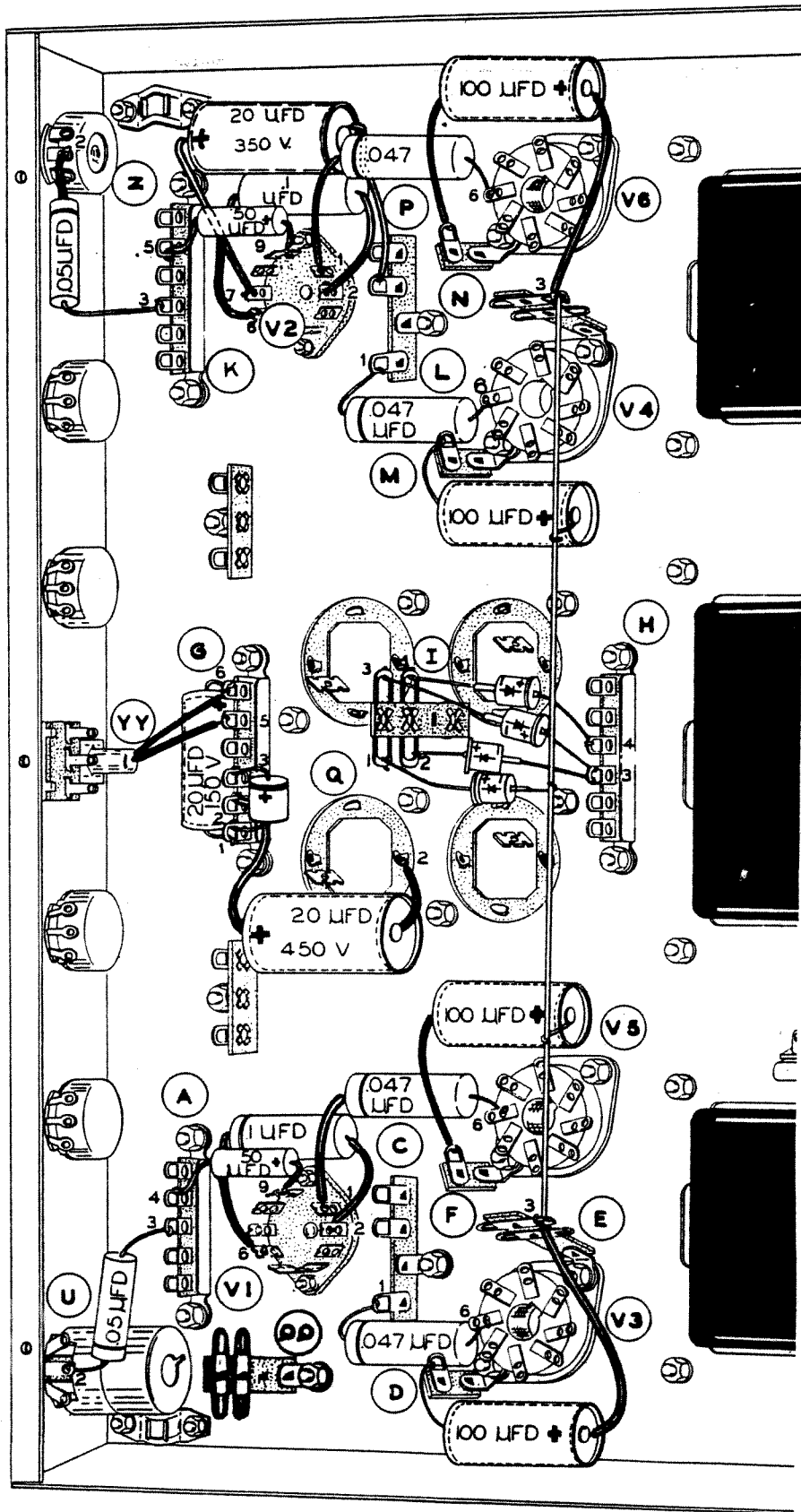

Pictorial 4

Final Wiring

Refer to Pictorial 4 for the following steps.

- () C1. Connect a .05 μ fd tubular capacitor from lug 2 of control U (S-1) to lug 3 of terminal strip A (NS).
- () C5. Connect a .1 μ fd tubular capacitor from lug 6 (NS) to lug 2 (NS) of tube socket V1. Use sleeving on both leads.
- () C7. Connect a .047 μ fd tubular capacitor from lug 1 of tube socket V1 (NS) to lug 6 of tube socket V5 (NS). Use sleeving on the lead to V1.
- () C9. Connect another .047 μ fd tubular capacitor from lug 1 of terminal strip C (NS) to lug 6 of tube socket V3 (NS).
- () C2. Connect a .05 μ fd tubular capacitor from lug 2 of control Z (S-1) to lug 3 of terminal strip K (S-2). Use sleeving on the lead to control Z.
- () C6. Connect a .1 μ fd tubular capacitor from lug 6 (NS) to lug 2 (NS) of tube socket V2. Use sleeving on both leads.
- () C8. Connect a .047 μ fd tubular capacitor from lug 1 of tube socket V2 (NS) to lug 6 of tube socket V6 (NS). Use sleeving on the lead to V2.
- () C10. Connect another .047 μ fd tubular capacitor from lug 1 of terminal strip L (NS) to lug 6 of tube socket V4 (NS).
- () C15. Connect another 100 μ fd, 50 V electrolytic capacitor from the lug of terminal strip F (NS) to the bus wire (S-1). Use sleeving on the lead to terminal strip F. The + lead goes to the bus wire..
- () C24. Connect a 20 μ fd, 450 V electrolytic capacitor from lug 2 of terminal strip G (NS) to lug 2 of capacitor Q (NS). Use sleeving on both leads. The + lead goes to terminal strip G.
- () C29. Connect a 20 μ fd, 150 V electrolytic capacitor from lug 1 (NS) to lug 6 (NS) of terminal strip G. The + lead goes to lug 6.
- () C23. Connect a 20 μ fd 350 V electrolytic capacitor from lug 2 of terminal strip L (NS) to lug 7 of tube socket V2 (S-2). Use sleeving on both leads. The + lead goes to V2.
- () C4. Connect a 50 μ fd, 15 V electrolytic capacitor from lug 5 of terminal strip K (NS) to lug 9 of tube socket V2 (NS). Use sleeving on both leads. The + lead goes to V2.
- () C16. Connect a 100 μ fd, 50 V electrolytic capacitor from the lug of terminal strip M (NS) to the bus wire (S-1). The + lead goes to the bus wire.
- () C18. Connect another 100 μ fd, 50 V electrolytic capacitor from the lug of terminal strip P (NS) to lug 3 of terminal strip N (S-4). Use sleeving on both leads. The + lead goes to terminal strip N.
- () D1. Connect the selenium diode from lug 1 (S-4) to lug 3 (S-2) of terminal strip G. Place the positive (+) end as shown in Pictorial 4. Use a pair of long-nose pliers, with a rubber band wrapped around the handles, as a heat sink to prevent damage by heat when soldering the connections. Refer to Detail 4A.

IMPORTANT: WHEN INSTALLING ELECTROLYTIC CAPACITORS IN THE FOLLOWING STEPS, MAKE SURE THAT THE POSITIVE (+) ENDS ARE PLACED AS SHOWN IN PICTORIAL 4. POSITION THE CAPACITORS AS SHOWN, AND CUT LEADS AS REQUIRED BEFORE CONNECTING.

- () C3. Connect a 50 μ fd, 15 V electrolytic capacitor from lug 4 of terminal strip A (NS) to lug 9 of tube socket V1 (NS). Use sleeving on both leads. The + lead goes to V1.
- () C17. Connect a 100 μ fd, 50 V electrolytic capacitor from the lug of terminal strip D (NS) to lug 3 of terminal strip E (S-4). Use sleeving on the lead to terminal strip E. The + lead goes to terminal strip E.

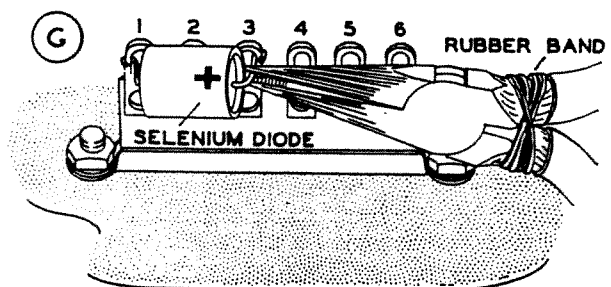

Detail 4A

NOTE: When installing silicon diodes in the following steps, use the diode symbol and polarity markings in Pictorial 4 to identify the positive (+) and negative leads. Also, use a pair of long-nose pliers as a heat sink on the diode leads when soldering the connections.

- () D4. Connect the positive (+) lead of a silicon diode to lug 2 of terminal strip I (S-1). Connect the other lead of this diode to lug 3 of terminal strip H (NS).
- () D3. Connect the positive (+) lead of another silicon diode to lug 3 of terminal strip H (S-3). Connect the other lead of this diode to lug 3 of terminal strip I (S-1).
- () D5. Connect the positive (+) lead of a third silicon diode to lug 4 of terminal strip H (S-2). Connect the other lead of this diode to lug 4 of terminal strip I (S-1).
- () D2. Connect the positive (+) lead of the remaining silicon diode to lug 1 of terminal strip I (S-1). Connect the other lead of this diode to the bus wire as close as possible to the wire coming from lug 2 of capacitor S (S-2).

NOTE: Be sure none of the diodes are touching each other.

- () Place a 1-1/4" length of sleeving over each pilot lamp lead; then, connect one lead to lug 5 (NS) and the other lead to lug 6 (S-5) of terminal strip G.

Remaining Component Installation

Refer to Pictorial 5 for the following steps.

- () R37. Connect a 47 Ω (yellow-violet-black) 1 watt resistor from the lug of terminal strip CC (NS) to lug 4 of terminal strip DD (S-2).
- () C21. Connect a .05 μ fd disc capacitor from the lug of terminal strip CC (S-2) to lug 1 of slide switch BB (S-2). Use sleeving on the lead to switch BB.
- () C19. Connect a 910 μ mf mica capacitor from the lug of terminal strip EE (NS) to lug 1 of terminal strip HH (NS).
- () R39. Connect a 2400 Ω (red-yellow-red-gold) 5% resistor from the lug of terminal strip EE (S-3) to lug 1 of terminal strip HH (S-3).

- () R38. Connect a 47 Ω (yellow-violet-black) 1 watt resistor from lug 2 of terminal strip LL (S-2) to the lug of terminal strip MM (NS).
- () C22. Connect a .05 μ fd disc capacitor from lug 5 of terminal strip LL (NS) to the lug of terminal strip MM (S-2).
- () C20. Connect a 910 μ mf mica capacitor from the lug of terminal strip KK (NS) to lug 5 of terminal strip LL (NS).
- () R40. Connect a 2400 Ω (red-yellow-red-gold) 5% resistor from the lug of terminal strip KK (S-3) to lug 5 of terminal strip LL (S-4).

IMPORTANT: Do not use the 22 K Ω matched 1 watt resistors until they are specifically called for.

- () R29. Connect a 22 K Ω (red-red-orange) resistor between lugs 5 (NS) and 6 (NS) of tube socket V3.
- () R25. Connect a 220 K Ω (red-red-yellow) resistor from the lug of terminal strip D (S-3) to lug 6 of tube socket V3 (NS).
- () C13. Connect a 200 μ mf mica capacitor between lugs 5 (S-2) and 6 (S-4) of tube socket V3.
- () R35. Connect a 6 Ω 1% resistor from lug 8 of tube socket V3 (S-2) to lug 4 of terminal strip E (S-1).
- () R31. Connect a 12 Ω 1% resistor between lugs 1 (S-1) and 2 (NS) of terminal strip E.
- () R33. Connect a 6 Ω 1% resistor from lug 2 of terminal strip E (S-2) to lug 8 of tube socket V5 (S-2).
- () R27. Connect a 22 K Ω (red-red-orange) resistor between lugs 5 (NS) and 6 (NS) of tube socket V5.
- () R23. Connect a 220 K Ω (red-red-yellow) resistor from the lug of terminal strip F (S-3) to lug 6 of tube socket V5 (NS).
- () C11. Connect a 200 μ mf capacitor between lugs 5 (S-2) and 6 (S-4) of tube socket V5.

- () R19. Connect a matched 22 K Ω (red-red-orange) 1 watt resistor between lugs 1 (NS) and 2 (S-3) of terminal strip C.
- () R17. Connect a 2700 Ω (red-violet-red) resistor from lug 1 of terminal strip C (NS) to lug 3 of tube socket V1 (S-1).
- () R15. Connect a 1 megohm (brown-black-green) resistor from lug 1 of terminal strip C (S-4) to lug 2 of tube socket V1 (S-2).
- () R21. Connect a matched 22 K Ω (red-red-orange) 1 watt resistor from lug 3 of terminal strip C (S-2) to lug 1 of tube socket V1 (S-2).
- () R11. Connect a 100 Ω (brown-black-brown-gold) 5% resistor between lugs 2 (NS) and 4 (NS) of terminal strip A.
- () R7. Connect a 1 megohm (brown-black-green) resistor between lugs 2 (S-4) and 5 (NS) of terminal strip A.
- () R3. Connect a 100 K Ω (brown-black-yellow) resistor between lugs 3 (S-3) and 5 (NS) of terminal strip A.
- () R13. Connect a 330 K Ω (orange-orange-yellow) resistor from lug 1 of terminal strip A (NS) to lug 6 of tube socket V1 (S-2).
- () R45. Connect an 820 K Ω (gray-red-yellow) resistor from lug 1 of terminal strip A (S-4) to lug 7 of tube socket V1 (S-2).
- () R9. Connect a 680 Ω (blue-gray-brown) resistor from lug 4 of terminal strip A (S-4) to lug 9 of tube socket V1 (S-2).
- () R5. Connect a 33 K Ω (orange-orange-orange) resistor from lug 5 of terminal strip A (S-3) to lug 8 of tube socket V1 (S-1).
- () R51. Connect a 68 K Ω (blue-gray-orange) resistor between lugs 1 (NS) and 3 (NS) of control V.
- () R55. Connect a 22 K Ω (red-red-orange) resistor from lug 1 of control V (S-2) to lug 1 of terminal strip B (NS).
- () R57. Connect another 22 K Ω resistor from lug 3 of control V (S-2) to lug 2 of terminal strip B (NS).
- () R65. Connect a 47 K Ω (yellow-violet-orange) resistor from lug 1 (S-2) to lug 3 (NS) of control W.
- () R59. Connect one lead of an 8200 Ω (gray-red-red) resistor through lug 3 (NS) to lug 2 (NS) of control W. Now solder lug 3 (S-3).
- () Connect the other lead of this resistor to lug 2 of terminal strip B (S-3).
- () R61. Connect another 8200 Ω (gray-red-red) resistor from lug 2 of control W (S-2) to lug 1 of terminal strip B (S-3).
- () R66. Connect a 47 K Ω (yellow-violet-orange) resistor from lug 1 (S-2) to lug 3 (NS) of control X.
- () R62. Connect one lead of an 8200 Ω (gray-red-red) resistor through lug 3 (NS) to lug 2 (NS) of control X. Now solder lug 3 (S-3).
- () Connect the other lead of this resistor to lug 2 of terminal strip J (NS).
- () R60. Connect another 8200 Ω resistor from lug 2 of control X (S-2) to lug 1 of terminal strip J (NS).
- () R52. Connect a 68 K Ω (blue-gray-orange) resistor between lugs 1 (NS) and 3 (NS) of control Y.
- () R58. Connect a 22 K Ω (red-red-orange) resistor from lug 1 of control Y (S-2) to lug 1 of terminal strip J (S-3).
- () R56. Connect another 22 K Ω resistor from lug 3 of control Y (S-2) to lug 2 of terminal strip J (S-3).
- () R12. Connect a 100 Ω (brown-black-brown-gold) 5% resistor between lugs 2 (NS) and 5 (NS) of terminal strip K.
- () R8. Connect a 1 megohm (brown-black-green) resistor between lugs 2 (S-4) and 6 (NS) of terminal strip K.
- () R4. Connect a 100 K Ω (brown-black-yellow) resistor between lugs 4 (S-2) and 6 (NS) of terminal strip K.
- () R14. Connect a 330 K Ω (orange-orange-yellow) resistor from lug 1 of terminal strip K (S-3) to lug 6 of tube socket V2 (S-2).

- () R10. Connect a 680 Ω (blue-gray-brown) resistor from lug 5 of terminal strip K (S-4) to lug 9 of tube socket V2 (S-2).
- () R6. Connect a 33 K Ω (orange-orange-orange) resistor from lug 6 of terminal strip K (S-3) to lug 8 of tube socket V2 (S-1).
- () R18. Connect a 2700 Ω (red-violet-red) resistor from lug 3 of tube socket V2 (S-1) to lug 1 of terminal strip L (NS).
- () R16. Connect a 1 megohm (brown-black-green) resistor from lug 2 of tube socket V2 (S-2) to lug 1 of terminal strip L (NS).
- () R22. Connect a matched 22 K Ω (red-red-orange) 1 watt resistor from lug 1 of tube socket V2 (S-2) to lug 3 of terminal strip L (S-2).
- () R20. Connect another matched 22 K Ω 1 watt resistor between lugs 1 (S-4) and 2 (S-4) of terminal strip L.
- () R30. Connect a 22 K Ω (red-red-orange) resistor between lugs 5 (NS) and 6 (NS) of tube socket V4.
- () R26. Connect a 220 K Ω (red-red-yellow) resistor from the lug of terminal strip M (S-3) to lug 6 of tube socket V4 (NS).
- () C14. Connect a 200 $\mu\mu\text{f}$ capacitor between lugs 5 (S-2) and 6 (S-4) of tube socket V4.
- () R36. Connect a 6 Ω 1% resistor from lug 8 of tube socket V4 (S-2) to lug 4 of terminal strip N (S-1).
- () R32. Connect a 12 Ω 1% resistor between lugs 1 (S-1) and 2 (NS) of terminal strip N.
- () R28. Connect a 22 K Ω (red-red-orange) resistor between lugs 5 (NS) and 6 (NS) of tube socket V6.
- () R24. Connect a 220 K Ω (red-red-yellow) resistor from terminal strip P (S-3) to lug 6 of tube socket V6 (NS).
- () C12. Connect a 200 $\mu\mu\text{f}$ capacitor between lugs 5 (S-2) and 6 (S-4) of tube socket V6.
- () R34. Connect a 6 Ω 1% resistor from lug 2 of terminal strip N (S-2) to lug 8 of tube socket V6 (S-2).
- () R46. Connect a 10 K Ω (brown-black-orange) 2 watt resistor between lugs 2 (S-4) and 4 (NS) of terminal strip G.
- () R47. Connect a 470 K Ω (yellow-violet-yellow) resistor between lugs 4 (S-3) and 5 (S-2) of terminal strip G.
- () R49. Connect a 100 K Ω (brown-black-yellow) 2 watt resistor between lugs 1 (S-2) and 2 (S-3) of capacitor Q. Use sleeving on both leads.
- () R48. Connect another 100 K Ω 2 watt resistor between lugs 1 (S-3) and 2 (S-1) of capacitor R. Use sleeving on both leads.
- () R43. Connect a 10 K Ω (brown-black-orange-gold) 5% resistor from lug 1 of terminal strip H (S-3) to the bus wire (S-1).
- () R41. Connect another 10 K Ω 5% resistor from lug 2 of terminal strip H (S-3) to the bus wire (S-1).
- () R44. Connect a third 10 K Ω 5% resistor from lug 5 of terminal strip H (S-3) to the bus wire (S-1).
- () R42. Connect the remaining 10 K Ω 5% resistor from lug 6 of terminal strip H (S-3) to the bus wire (S-1).
- () Install the line cord and line cord strain relief in the hole adjacent to AC socket NN as shown in Detail 5A. There should be approximately 3" of the line cord inside of the chassis.
- () Connect one of the line cord wires to lug 1 (S-2) and the other to lug 2 (S-2) of AC socket NN.

This completes all of the wiring operations under the chassis and is a good time to make sure that all leads and components are placed and connected as shown in Pictorials 1 through 5.

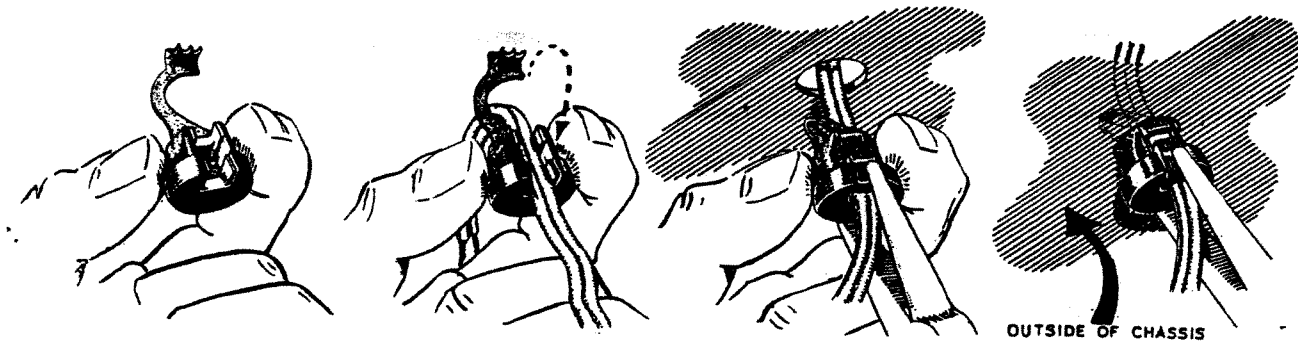

Detail 5A

Initial Test

- () Make sure that there are no short circuits in the wiring caused by wire clippings or stray pieces of solder.
- () Recheck the surgistor adjustment. The space between the points should equal two thicknesses of the material of the carton in which the surgistor was shipped.
- () If an ohmmeter is available, it would be well to check against the possibility of short circuits in the B+ and bias supplies before applying power for the first time. To make this check on the B+ supply, measure resistance between lug 1 of capacitor T and chassis. With the ohmmeter set on one of the higher ranges, the meter pointer should

"kick" down to a fairly low reading indicating charging of the filter capacitor and then rise slowly to a reading of at least 100,000 ohms. If a reading of less than 100,000 ohms is obtained, reverse the ohmmeter leads, after first discharging lug 1 of capacitor T to chassis. If the reading is still less than 100,000 ohms, refer to the IN CASE OF DIFFICULTY section of the manual.

To check the bias supply, measure the resistance between lug 1 of terminal strip G and chassis. After the capacitor charge, the reading should be in the range of 15,000 - 20,000 ohms. Ohmmeter polarity is not critical for this test.

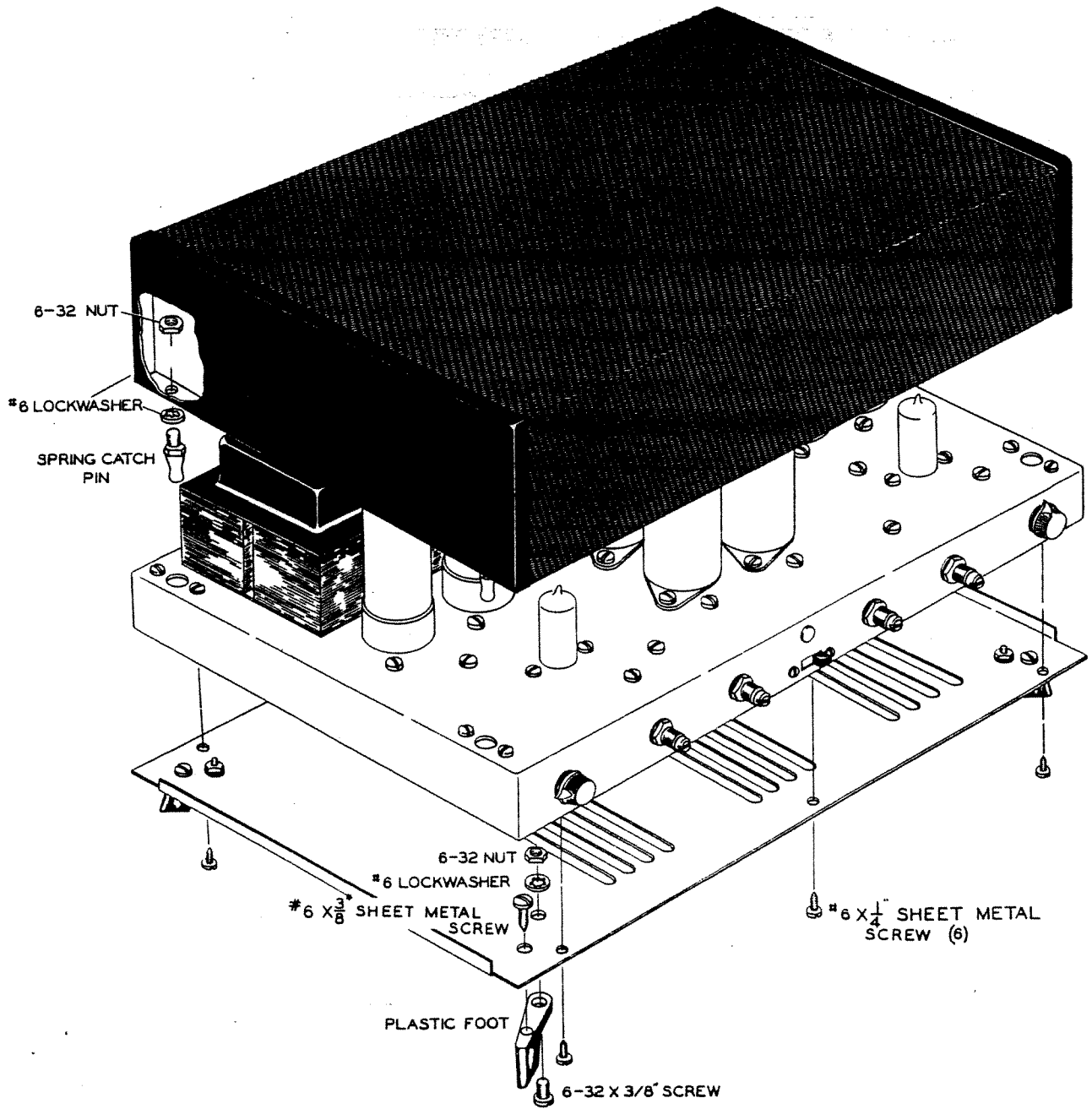

Pictorial 6

Final Assembly

Refer to Pictorial 6 for the following steps.

- () Install the four plastic feet on the bottom plate as shown in Pictorial 6. Use #6 x 3/8" sheet metal screws, 6-32 x 3/8" screws, #6 lockwashers and 6-32 nuts.
- () Mount the bottom plate on the bottom of the chassis with six #6 x 1/4" sheet metal screws.
- () Install the 4 ampere slow-blow fuse in the fuse holder.

IMPORTANT WARNING: TUBES CAN BE DAMAGED WHEN INSTALLING THEM IN THEIR SOCKETS. THEREFORE, USE EXTREME CARE WHEN INSTALLING TUBES AS WE DO NOT GUARANTEE OR REPLACE TUBES BROKEN DURING HANDLING OR INSTALLATION.

- () Install the four type EL34 tubes in the octal tube sockets.
- () Install the two type 6AN8 tubes in the 9-pin tube sockets.

() Install the four spring catch pins at the corners of the top cover with #6 lockwashers and 6-32 nuts. Be sure to place each lockwasher directly on each catch pin, as shown. The nuts should be only finger tight.

() Now, set the top cover over the chassis so that the spring catch pins line up with the spring catch clips on the chassis and press the top cover down into place. Since the nuts on the spring catch pins are only finger tight, this will properly position the spring catch pins.

() Carefully lift the top cover from the chassis and tighten the nuts on the spring catch pins, then replace the top cover over the chassis.

() Install the two small pointer knobs on the LEVEL controls. Before tightening the set-screws in these knobs, make sure that the knob pointers line up with the markings on the front chassis flange at the ends of control rotation. Note that the AC switch is actuated at the extreme counterclockwise end of the "A" CHAN. LEVEL control rotation.

This completes assembly of the AA-121 Amplifier. Make the adjustments directed in the following section before attempting to put the amplifier into operation.

ADJUSTMENT

The purpose of these adjustments is to set the amount of current drawn by the output tubes and to balance the push-pull output stages in each channel.

These adjustments are made without an input signal and without speakers connected to the amplifier outputs. In performing the following steps, if proper balance cannot be obtained or if the actual voltage readings are higher than called for in the steps, immediately turn the amplifier off and refer to the IN CASE OF DIFFICULTY section.

- () Turn the "A" CHAN. LEVEL control to the AC OFF position and rotate the "B" CHAN. LEVEL control fully counterclockwise.
- () Place the FUNCTION SELECTOR switch in the STEREO position.

() Rotate the BIAS VOLTAGE controls fully counterclockwise.

() Set the BIAS BALANCE controls to the middle of their rotation.

() Insert the line cord plug into a 117 volt 50/60 cycle AC receptacle.

() Rotate the "A" CHAN. LEVEL control just far enough clockwise to operate the AC switch. The pilot lamp should light and the tube filaments should begin to warm up. If the pilot lamp does not light or if any overheating is noticed, immediately unplug the line cord and refer to the IN CASE OF DIFFICULTY section of this manual. However, bear in mind that the pilot lamp will not light to full intensity until the surgistor operates, several seconds after power is applied. Note also that it is normal for the surgistor to smoke slightly the first time power is applied.

- () If operation thus far seems satisfactory, allow the amplifier to warm up for at least five minutes, then proceed with the adjustments.
- () Set a DC voltmeter to one of its higher ranges (50 volts or more), then connect the voltmeter across the A Channel BASS-BAL METER jacks on the rear chassis apron.
- () Rotate the "A" CHAN. BIAS BALANCE control until the voltmeter indicates 0 volts. Now set the voltmeter to its lowest range and again adjust the "A" CHAN. BIAS BALANCE control for a 0 volt indication on the voltmeter. Disconnect one of the voltmeter leads from the BASS-BAL METER jacks. If the voltage is actually 0 volts, the meter pointer will not move when the voltmeter lead is disconnected.
- () Repeat the preceding adjustment steps for the B Channel, using the B Channel BASS-BAL METER jacks and "B" CHAN. BIAS BALANCE control.
- () After both channels have been balanced, set the voltmeter to a range that will accurately indicate 1.5 volts DC. Now, connect the common voltmeter lead to the A Channel 8 Ω speaker terminal and insert the DC probe into either A Channel BASS-BAL METER terminal.
- () Adjust the "A" CHAN. BIAS VOLTAGE control until the voltmeter reads 1.5 volts \pm .1 volt.
- () Leave the common voltmeter lead connected to the A Channel 8 Ω speaker terminal. Insert the DC probe into either B Channel BASS-BAL METER terminal.
- () Adjust the "B" CHAN BIAS VOLTAGE control until the voltmeter reads 1.5 volts \pm .1 volt.
- () Repeat all of the preceding adjustment steps for both channels. This is necessary to obtain proper balance and correct bias settings since the different adjustments interact.
- () Carefully install the four plastic cap nuts on the BIAS BALANCE and VOLTAGE controls so that the adjustments will not be disturbed.

After the AA-121 Amplifier has been in operation for five hours, the bias adjustments should be repeated to compensate for any change in tube characteristics as the tubes stabilize. The bias adjustments should also be checked at three month intervals after the amplifier is put into operation.

If one of the output tubes is replaced or if the output tubes are interchanged, the bias adjustments should be repeated.

Refer to the INSTALLATION AND OPERATION section which follows for information on connecting the AA-121 Amplifier to other equipment and using it effectively.

INSTALLATION AND OPERATION

The appearance of the AA-121 Amplifier is such that it can be attractively located in the open, however, basic audio amplifiers are generally placed out of sight, on a shelf or in an equipment cabinet.

Regardless of the type of physical installation, ventilation is of prime importance. The amplifier location should allow air circulation around the amplifier and through its top cover. At least two inches of air space should be provided on all sides and above the amplifier. The plastic feet allow sufficient space for ventilation under the amplifier.

Shielded cables terminated in phono plugs should be used to make signal connections to the input jacks of the AA-121 Amplifier.

Connections from the amplifier outputs to the speaker systems may be made with standard AC lamp cord or flat television antenna lead-in wire. Lamp cord is considered preferable for this application.

Because the AA-121 Amplifier is compatible with a large variety of high fidelity components, specific recommendations for selecting accessory equipment are not included in this manual; however, in choosing accessory equipment, care should be taken to obtain components with good high fidelity characteristics similar to those of the amplifier.

A typical stereo high fidelity system using the AA-121 Amplifier is shown in the following illustration.

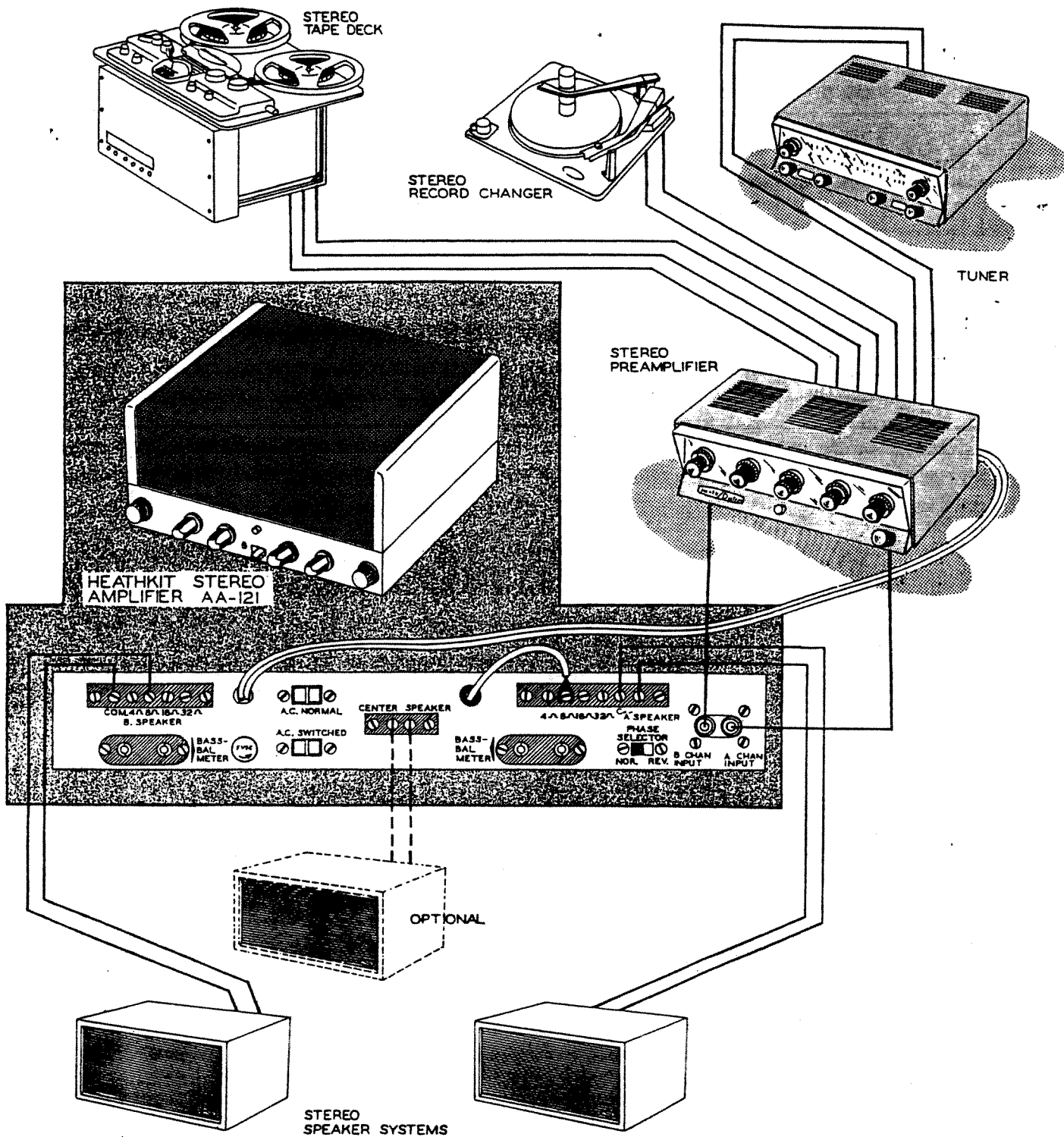

Generally, the input signals for the amplifier will be provided by a stereo preamplifier or possibly by a high level signal source such as a crystal phono cartridge or radio tuner having relatively high signal voltage output.

For best stereo results, the right and left speaker systems should be identical. The proper locations for the speaker systems will probably be found by experimentation, however, good stereo coverage will usually result if the speaker systems are placed as far apart as possible on the short wall of the listening room.

The leads from the left (A Channel) speaker system should be connected to the pair of terminals labeled "A" SPKR on the A Channel speaker terminal strip. The spade lug on the end of the wire coming through grommet GG should be connected to the terminal whose designation corresponds to the impedance of the speaker system.

For the right (B Channel) speaker system, connect one lead to the COM. terminal on the B Channel speaker terminal strip. Connect the other lead to the terminal whose designation corresponds to the impedance of the speaker system.

Normally, the output of both channels of this amplifier are connected to suitable speaker systems. If you intend to use only one speaker system, connect it to one of the channels, and connect the other channel to a resistive load. The resistive load will prevent the unused channel from "running free," which could damage the circuit parts in the output stage of an unused channel.

You may use a 4 Ω , 8 Ω , or 16 Ω high wattage resistor for the resistive load. Connect this resistor to the proper output terminals of the unused channel.

A third speaker system may be connected to the CENTER SPEAKER terminals, if desired. The third speaker system may be used to offset the "hole-in-the-middle" effect present in some stereo material.

The signal for the center speaker is proportional to the instantaneous sum of the A and B signals; therefore, this signal is maximum when the A and B signals are in-phase, and is zero if the A and B signals happen to be out-of-phase. Because of these relationships, reproduction by the center speaker will be correct to provide center fill without sacrificing stereo effectiveness.

An adjustable L-pad is needed to allow setting the volume level of the center speaker. For

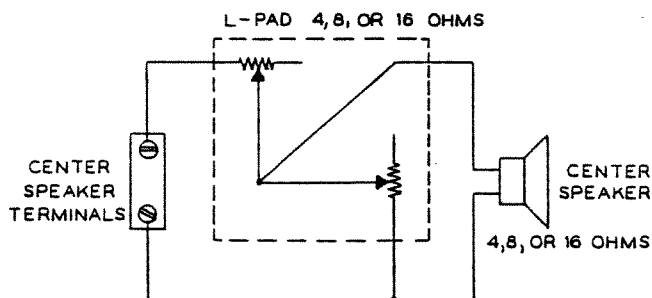

optimum center fill, only a low volume is desired from the center speaker. For this reason the type of speaker used for this purpose is not critical. The speaker impedance may be 4, 8 or 16 Ω . The following diagram shows the proper way to connect an L-pad and speaker to the CENTER SPEAKER terminals of the AA-121 Amplifier.

Normally, the outputs of both channels of this amplifier are connected to suitable speaker systems. If you intend to use only one speaker system, connect it to one of the channels, and connect the other channel to a resistive load. The resistive load will prevent the unused channel from "running free," which could damage the circuit parts in the output stage of an unused channel.

You may use a 4 Ω , 8 Ω , or 16 Ω high wattage resistor for the resistive load. Connect this resistor to the proper output terminals of the unused channel.

As an alternative, for monophonic operation with only one speaker system, you may connect jumper wires as described in the following paragraphs.

For some audio amplifier applications it is feasible to use the combined power of both amplifier channels to drive a single pair of speaker terminals for monophonic speaker operation. If this type of operation is desired, first connect the monophonic speaker load to the "A" SPKR. terminals on the A Channel speaker terminal strip.

Now, prepare two jumper wires by soldering a #6 spade lug to each end of two 12" lengths of the stranded hookup wire.

Connect one of these jumper wires from the "C" terminal of the A Channel output to the COM. terminal of the B Channel output.

If an impedance of 16 Ω is desired at the "A" SPKR. terminals, connect the other jumper wire from the 32 Ω terminal of the A Channel output to the 32 Ω terminal of the B Channel output. For an impedance of 8 Ω , connect this jumper

wire between the 16 Ω terminals; for 4 Ω , connect the jumper wire between the 8 Ω terminals.

For monophonic speaker operation as just described, the PHASE SELECTOR switch must be in the NORMAL position. Also, the FUNCTION SELECTOR switch should be in the MON. position. With the FUNCTION SELECTOR switch in the MON. position, only the MON. LEVEL control will be effective.

NOTE: The jumper wires should be used only for monophonic speaker operation. The jumper wires are not used when the AA-121 Amplifier is operated stereophonically or monaurally with speaker systems connected to both the A and B Channel outputs.

The following paragraphs describe the control functions of the AA-121.

AC switch: This switch is located on the "A" CHAN. LEVEL control and is used to turn the amplifier on and off.

"A" CHAN. LEVEL AND MON. LEVEL control: This control adjusts the level of the input signal to the A Channel amplifier when the FUNCTION SELECTOR switch is in the STEREO position. When the FUNCTION SELECTOR switch is in the MON. position, this control adjusts the level of the input signal to both A and B Channels.

"B" CHAN. LEVEL control: This control adjusts the level of the input signal to B Channel amplifier.

FUNCTION SELECTOR switch: This switch is used to select monophonic or stereo operation. When this switch is in the STEREO position, the A and B Channels are driven individually by signals applied to the "A" CHAN. and "B" CHAN. INPUT jacks. With this switch in the MON. position, both channels are driven only by the signal applied to the "A" CHAN. INPUT jack.

"A" CHAN. and "B" CHAN. BIAS VOLTAGE and BALANCE controls: By means of the VOLTAGE control for each channel amplifier, negative bias voltage applied to the grids of the two output tubes may be adjusted to produce exactly the proper value of plate current in these tubes. The BALANCE control for each amplifier permits an even finer adjustment of the balance, or equality, of plate current between the two tubes. Precision resistors in the cathode circuits of these tubes permit the adjustments to be readily made using only a voltmeter for current and balance indication.

Use of the PHASE SELECTOR switch: Located on the rear chassis flange, this switch reverses

the phase of the A Channel at the loudspeaker terminals. The two speakers should be so connected that they are "in-phase" when this switch is in its NOR (normal) position. "In-phase" means that both speaker cones move in the same direction, when influenced by the same signal.

(If two-way speaker systems are used, phasing refers to the low frequency woofers.) It has been found that stereo reproduction is more satisfactory if the speakers are in-phase.

Assuming identical speakers, phasing should be proper (with switch in NOR) if the corresponding terminal on each speaker is connected to the common "C" amplifier terminals from each channel.

If you are in doubt as to the connection for proper phasing, it can be determined in the following manner: if an audio-frequency signal generator is available, connect it to the A CHAN. INPUT. Switch FUNCTION SELECTOR to MON. Now place the speakers side by side. At a frequency of approximately 100 cycles, use a level that is medium-loud when you stand directly in front of the speakers. Determine which position of the PHASE SELECTOR switch produces the loudest sound when you stand directly in front of, and quite close to, the speakers. If this is the NOR position, the speakers are in-phase when the switch is in NOR. If it is the REV position, reverse the wires to one of the speakers; then they will be in-phase when the switch is in NOR. This is the position in which the switch should normally be left. If you encounter stereo program material which seems to be out-of-phase, as is sometimes the case, you can correct it by throwing the switch to REV.

If an audio generator is not available, a 60-cycle hum may be used as a substitute signal. Possibly the easiest way to derive such a hum is to disconnect one of the low-level input sources, such as magnetic phono cartridge from the preamplifier used with your AA-121, and advance the level control of the preamplifier until the hum level is sufficiently loud. If necessary, the appropriate hum balance control of the preamplifier can be rotated to increase the hum.

The AA-121 Amplifier can be turned on and off either with its own AC switch or by a preamplifier that has a switched AC outlet. Power switching by a preamplifier is considered preferable. If the AA-121 Amplifier is to be turned on and off by a separate preamplifier, turn the AC switch on and connect the amplifier line cord to the switched AC outlet of the preamplifier.

IN CASE OF DIFFICULTY

1. **Recheck the wiring.** Trace each lead in colored pencil on the Pictorial as it is checked. It is frequently helpful to have a friend check your work. Someone who is not familiar with the unit may notice something consistently overlooked by the constructor.
2. It is interesting to note that about 90% of the kits that are returned for repair, malfunction due to poor connections and soldering. Therefore, many troubles can be eliminated by reheating all connections to make sure that they are soldered as illustrated in the Figures found in the SOLDERING TECHNIQUES section of this manual.
3. Make sure that all tubes light up properly.
4. Check the tubes with a tube tester or by substitution of tubes of the same types and known to be good.
5. Check the values of the component parts. Be sure that the proper part has been wired into the circuit, as shown in the pictorial diagrams and as called out in the wiring instructions.
6. Check for bits of solder, wire ends or other foreign matter which may be lodged in the wiring beneath the chassis.
7. If, after careful checks, the trouble is still not located and a voltmeter is available, check voltage readings against those shown on the Schematic Diagram. NOTE: All voltage readings were taken with an 11 megohm input vacuum tube voltmeter. Voltages may vary 10% due to line voltage variations.
8. A review of the Circuit Description and Block Diagrams will prove helpful in indicating where to look for trouble.

Specific Problems

Output tubes will not balance: This could be caused by a seriously unbalanced pair of EL34 tubes, a leaky .047 μ fd coupling capacitor, or a defective component in the bias supply. Try interchanging the output tubes between A and B Channels. Also, check the coupling capacitors that go to the output stages.

Output tube current too high: Excessive output tube current is indicated by higher than normal voltage on the cathodes of the output tubes. This condition could be caused by a defective component in the bias supply, particularly the selenium diode, or by a faulty electrolytic filter capacitor in the B+ supply.

Hum: An open electrolytic filter capacitor in the B+ supply, improper ground connections in the amplifier, incorrect filament lead dress or a heater-cathode short in one of the tubes could cause hum.

The AA-121 Amplifier uses a ground circuit that is connected to the chassis only at the ground terminals of the input jacks. If a ground wire at some other circuit point is touching the chassis, a ground loop could result, causing hum.

Ground loops in the audio cables can also cause hum. Usually, the lowest overall hum will result if the shields of the audio cables are grounded at both ends; however, when there is more than one ground path between any two of the components of the stereo system, hum-causing ground loops are likely to result. If a ground loop is suspected of causing hum, try disconnecting the shield of one or more of the audio cables. When the AA-121 Amplifier is used with a preamplifier there must be at least one ground path between ground circuit of the AA-121. This ground path is usually through the shield of one or both of the audio cables.

Loss of Signal: A faulty tube, an open-circuited coupling capacitor, or a short circuit from the signal path to ground could cause signal loss; therefore, these points should be checked first.

A signal tracing procedure can also be used to locate the point of signal loss. First apply a suitable audio signal to an input, then, using either a signal tracer or an oscilloscope, check along the signal path to determine at which point the appropriate signal is missing. After obtaining this information, carefully check the associated wiring and parts.

CAUTION: Because there are high voltages present at several points in the AA-121 circuitry, due care should be exercised to avoid personal shock when performing the checks described above.

SERVICE

If, after applying the information in this manual and your best efforts, you are still unable to obtain proper performance, it is suggested that you take advantage of the technical facilities which the Heath Company makes available to its customers.

The Technical Consultation Department is maintained for your benefit. This service is available to you at no charge. Its primary purpose is to provide assistance for those who encounter difficulty in the construction, operation or maintenance of HEATHKIT equipment. It is not intended, and is not equipped to function as a general source of technical information involving kit modifications nor anything other than the normal and specified performance of HEATHKIT equipment.

Although the Technical Consultants are familiar with all details of this kit, the effectiveness of their advice will depend entirely upon the amount and the accuracy of the information furnished by you. In a sense, YOU MUST QUALIFY for GOOD technical advice by helping the consultants to help you. Please use this outline:

1. Before writing, fully investigate each of the hints and suggestions listed in this manual under "IN CASE OF DIFFICULTY." Possibly it will not be necessary to write.
2. When writing, clearly describe the nature of the trouble and mention all associated equipment. Specifically report operating procedures, switch positions, connections to other units and anything else that might help to isolate the cause of trouble.
3. Report fully on the results obtained when testing the unit initially and when following the suggestions under "IN CASE OF DIFFICULTY." Be as specific as possible and include voltage readings if test equipment is available.
4. Identify the kit model number and date of purchase, if available. Also mention the date of the kit assembly manual. (Date at bottom of Page 1.)
5. Print or type your name and address, preferably in two places on the letter.

With the preceding information, the consultant will know exactly what kit you have, what you would like it to do for you and the difficulty you wish to correct. The date of purchase tells him whether or not engineering changes have been made since it was shipped to you. He will know what you have done in an effort to locate the cause of trouble and, thereby, avoid repetitious suggestions. In short, he will devote full time to the problem at hand, and through his familiarity with the kit, plus your accurate report, he will be able to give you a complete and helpful answer. If replacement parts are required, they will be shipped to you, subject to the terms of the Warranty.

The Factory Service facilities are also available to you, in case you are not familiar enough with electronics to provide our consultants with sufficient information on which to base a diagnosis of your difficulty, or in the event that you prefer to have the difficulty corrected in this manner. You may return the completed equipment to the Heath Company for inspection and necessary repairs and adjustments. You will be charged a minimal service fee, plus the price of any additional parts or material required. However, if the completed kit is returned within the Warranty period, parts charges will be governed by the terms of the Warranty. State the date of purchase, if possible.

Local Service by Authorized HEATHKIT Service Centers is also available in some areas and often will be your fastest, most efficient method of obtaining service for your HEATHKIT equipment. Although charges for local service are generally somewhat higher than for factory service, the amount of increase is usually offset by the transportation charge you would pay if you elected to return your kit to the Heath Company.

HEATHKIT Service Centers will honor the regular 90 day HEATHKIT Parts Warranty on all kits, whether purchased through a dealer or directly from Heath Company; however, it will be necessary that you verify the purchase date of your kit.

Under the conditions specified in the Warranty,



replacement parts are supplied without charge; however, if the Service Center assists you in locating a defective part (or parts) in your kit, or installs a replacement part for you, you may be charged for this service.

HEATHKIT equipment purchased locally and returned to Heath Company for service must be accompanied by your copy of the dated sales receipt from your authorized HEATHKIT dealer in order to be eligible for parts replacement under the terms of the Warranty.

THIS SERVICE POLICY APPLIES ONLY TO COMPLETED EQUIPMENT CONSTRUCTED IN ACCORDANCE WITH THE INSTRUCTIONS AS STATED IN THE MANUAL. Equipment that has been modified in design will not be accepted for repair. If there is evidence of acid core solder or paste fluxes, the equipment will be returned NOT repaired.

For information regarding modification of HEATHKIT equipment for special applications, it is suggested that you refer to any one or more of the many publications that are available on all phases of electronics. They can be obtained at or through your local library, as well as at most electronic equipment stores. Although the Heath Company sincerely welcomes all comments and suggestions, it would be impossible to design, test, evaluate and assume responsibility for proposed circuit changes for special purposes. Therefore, such modifications must be made at the discretion of the kit builder, using information available from sources other than the Heath Company.

REPLACEMENTS

Material supplied with HEATHKIT products has been carefully selected to meet design requirements and ordinarily will fulfill its function without difficulty. Occasionally, improper operation can be traced to a faulty component. Should inspection reveal the necessity for replacement, write to the Heath Company and supply all of the following information.

- A. Thoroughly identify the part in question by using the part number and description found in the manual Parts List.
- B. Identify the type and model number of kit in which it is used.

C. Mention date of purchase.

D. Describe the nature of defect or reason for requesting replacement.

The Heath Company will promptly supply the necessary replacement. PLEASE DO NOT RETURN THE ORIGINAL COMPONENT UNTIL SPECIFICALLY REQUESTED TO DO SO. Do not dismantle the component in question as this will void the guarantee. This replacement policy does not cover the free replacement of parts that may have been broken or damaged through carelessness on the part of the kit builder.

SHIPPING INSTRUCTIONS

In the event that your instrument must be returned for service, these instructions should be carefully followed.

BECAUSE OF THE WEIGHT OF THE AA-121 AMPLIFIER, A WOOD BOX (OF PROPER DIMENSIONS) IS THE ONLY RECOMMENDED METHOD OF PACKAGING FOR SHIPMENT. Pictorial 7 shows construction and major dimensions of such a box. THE FOUR PLASTIC FEET AND THE TOP COVER SHOULD BE REMOVED FROM THE AMPLIFIER. THE TUBES SHOULD BE LEFT IN THEIR SOCKETS. It is recommended that audio cables used with your amplifier be returned with it, so that any defects in the cables themselves may be found and corrected.

Clearly address the packaged amplifier as follows:

To: HEATH COMPANY
Benton Harbor, Michigan

ATTACH A LETTER TO THE OUTSIDE OF THE CARTON BEARING YOUR NAME, COMPLETE ADDRESS, DATE OF PURCHASE, AND A BRIEF DESCRIPTION OF THE DIFFICULTY ENCOUNTERED. Also, include your name and return address on the outside of the carton. Preferably affix one or more "Fragile" or "Handle With Care" labels to the carton, or otherwise so mark with a crayon of bright color. Ship by insured parcel post or prepaid express; note that a carrier cannot be held responsible for damage in transit if, in HIS OPINION, the article is inadequately packed for shipment.

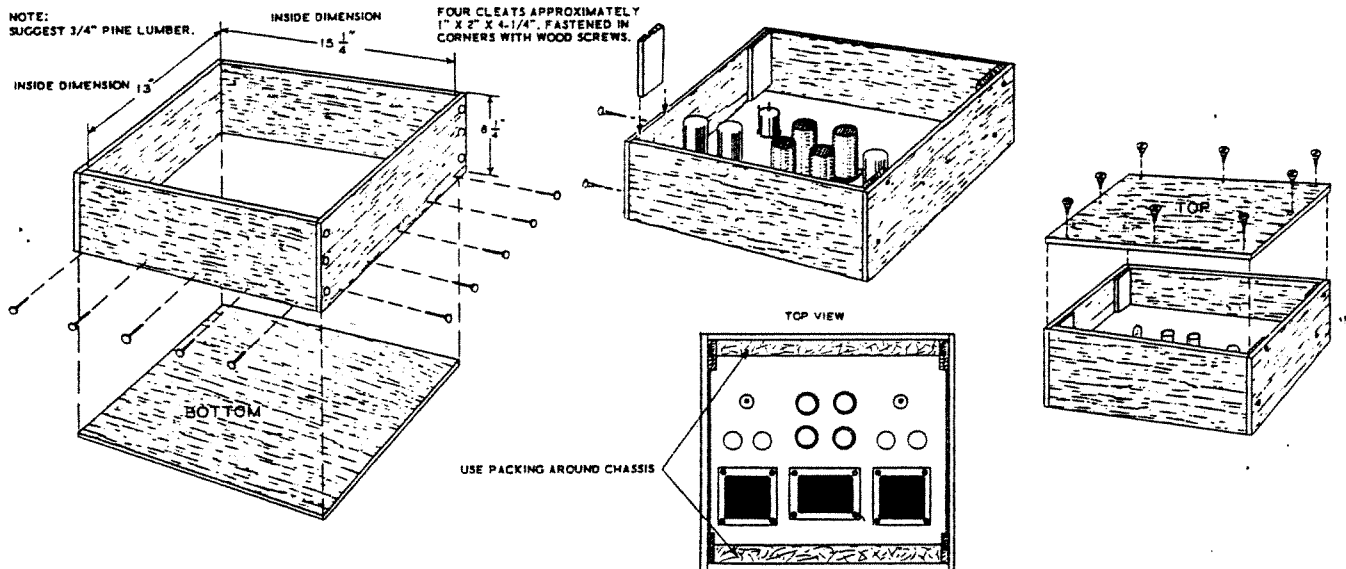

Pictorial 7

WARRANTY

Heath Company warrants that for a period of three months from the date of shipment, all Heathkit parts shall be free of defects in materials and workmanship under normal use and service and that in fulfillment of any breach of such warranty, Heath Company shall replace such defective parts upon the return of the same to its factory. The foregoing warranty shall apply only to the original buyer, and is and shall be in lieu of all other warranties, whether express or implied and of all other obligations or liabilities on the part of Heath Company and in no event shall Heath Company be liable for any anticipated profits, consequential damages, loss of time or other losses incurred by the buyer in connection with the purchase, assembly or operation of Heathkits or components thereof. No replacement shall be made of parts damaged by the buyer in the course of handling or assembling Heathkit equipment.

NOTE: The foregoing warranty is completely void and we will not replace, repair or service instruments or parts thereof in which acid core solder or paste fluxes have been used.

HEATH COMPANY

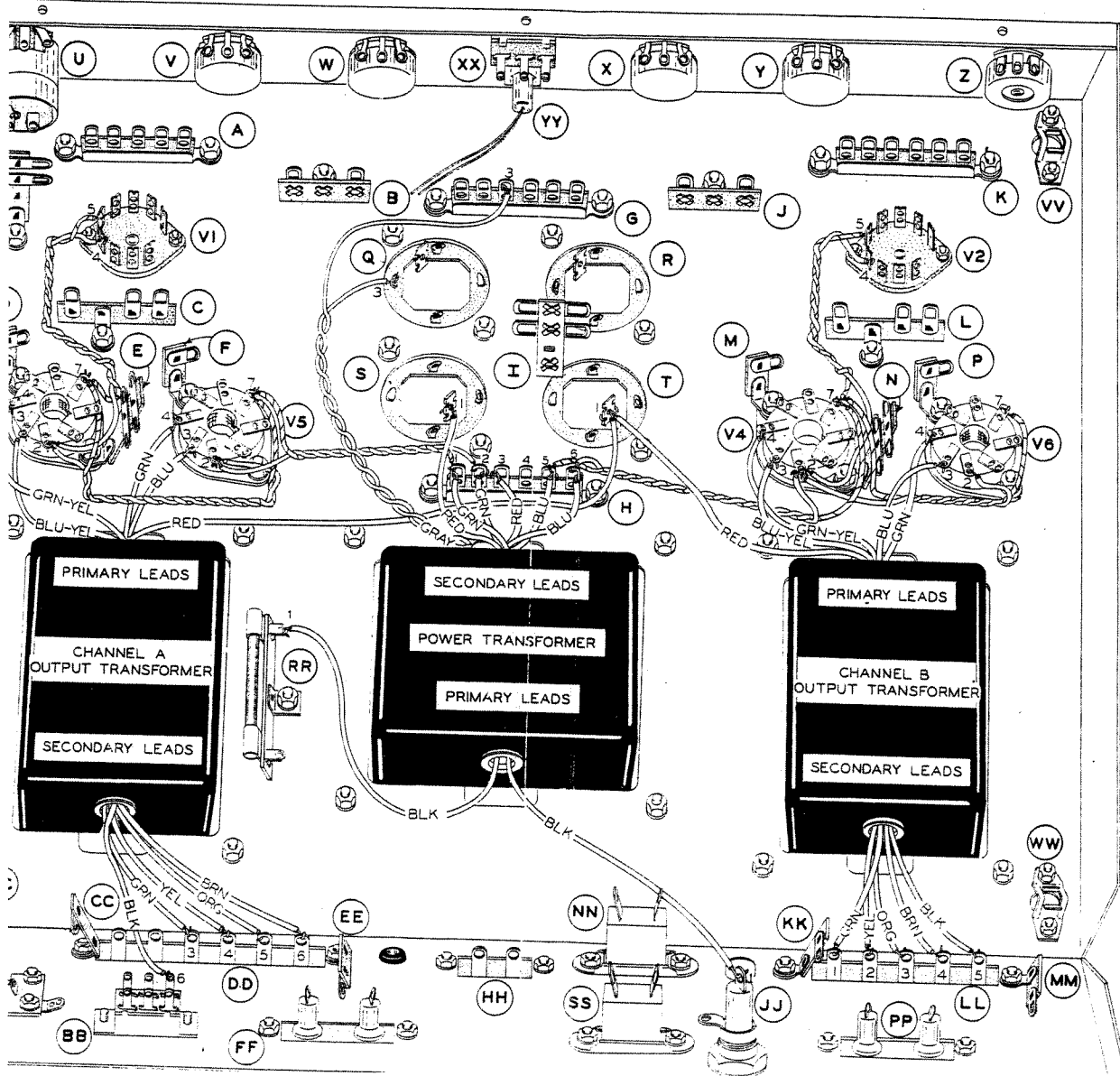

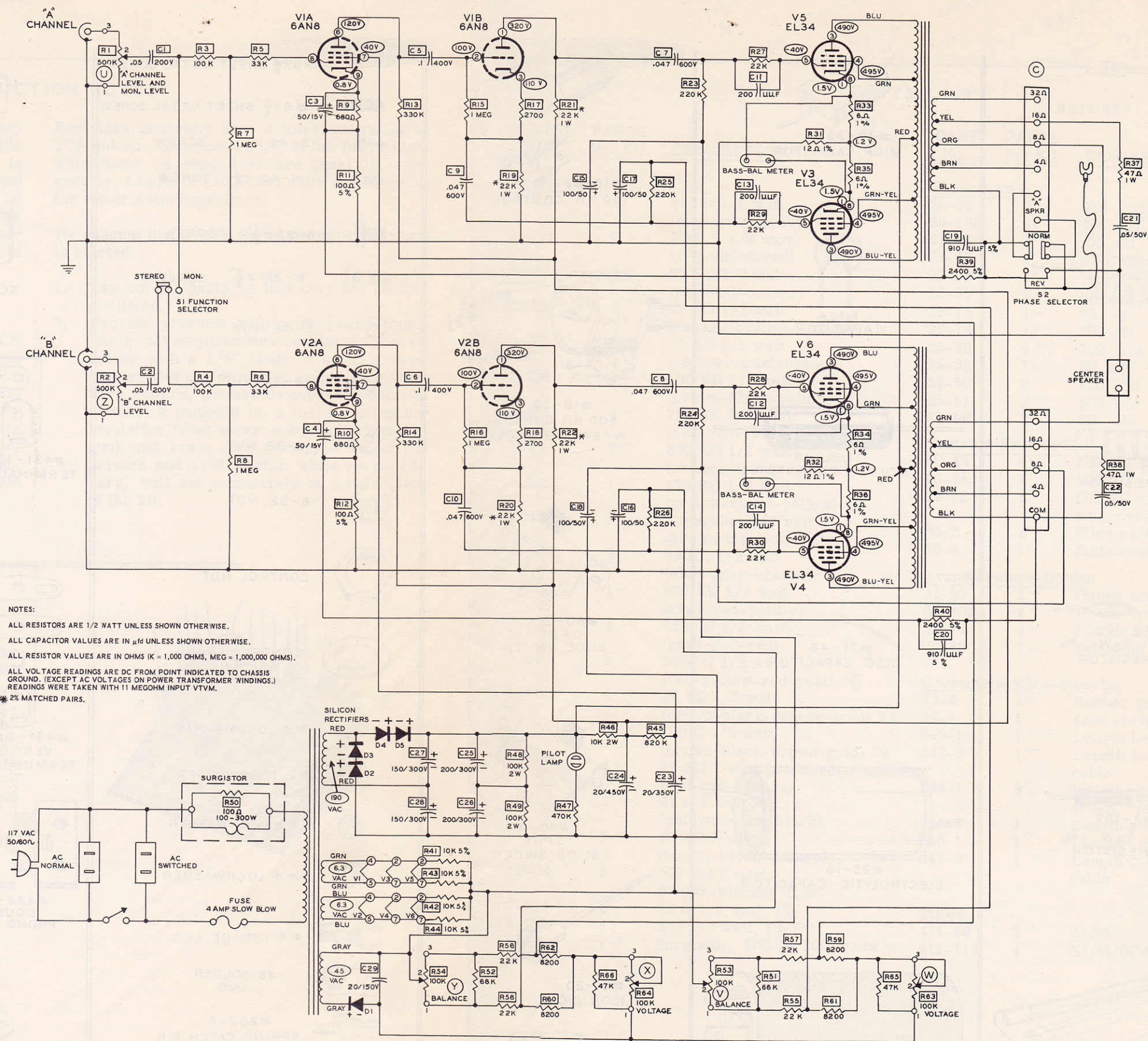

SCHEMATIC OF THE
HEATHKIT®
80 WATT AMPLIFIER
MODEL AA-121