



The Greening of the IG-18

By REGINALD WILLIAMSON

In which one of our redoubtable English cousins does a Professor Higgins on Heath's metered sine-square oscillator and turns an Eliza Doolittle into a lady of ravishing style and performance.

HOW WOULD YOU like to own a genuinely high grade sine and square wave audio generator? Just look at these specifications:

RANGE: 1 Hz - 100kHz sine or sq.

RISE TIME: 12 nanoseconds

T.H.D.: 0.01%; typically, 0.002-0.005%

ACCURACY: better than $\pm 0.5\%$

AMPLITUDE STABILITY: ± 1 dB.

Yes, I can hear you say, and where do I rustle up the \$400 or more for what is obviously a laboratory standard instrument? Well, you lucky *Audio Amateur* subscriber, read on, for you can be the proud owner of an instrument in this class and for a bare fraction of that price tag.

One of my professional tasks is evaluation of new products for the most popular of English audio magazines *Hi-Fi News*. Last year, I had the good fortune to undertake a review of the new Heathkit model IG-18 audio generator. This transistor version of their popular tubed model Ig-72 has identical performance and ranges, but also includes a square wave section.

Heath's specifications of the new model are modest, with a claim for less than 0.1% distortion, $\pm 5\%$ frequency accuracy and a square wave

rise time of better than 50 nanoseconds. In fact, a tolerably good performance for something aimed at the service shop or the not-so-critical amateur. The kit had a couple of errors when I came to check it out, but these were corrected with the willing cooperation of the British company. (I'll be mentioning these later on.)

In my subsequent appraisal of the product, therefore, I was pleased to give it a warm welcome, with a mild qualification about its total harmonic distortion which it barely met.

What about my warranty?

Later, however, while idly studying the schematic, I began to realize Heath had given us a laboratory standard instrument in embryo, since the basic circuit design philosophy was sound and needed just a few refinements here and there, to bring about quite a startling performance improvement.

To begin, you will need a Heath IG-18 audio generator kit costing \$67.50. One word of warning, how-

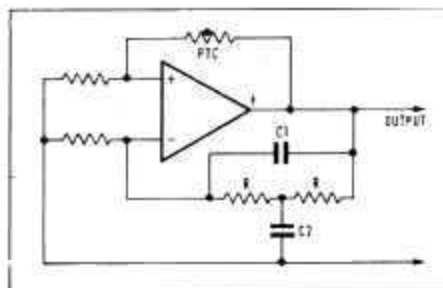

FIG.1. Simplified schematic of the operational amplifier Heath used in the IG-18 design. The triangle is the amplifier; its - input the inverting, the + the non-inverting.

ever. Quite rightly, our friends in Benton Harbor are perfectly entitled to invalidate their warranty if the owner makes unauthorized changes in their kit. Their excellent construction manuals usually make this quite clear. So first, you should build the kit as the manual directs and get it working exactly as they specify. In this way you can be sure the kit is free of basic flaws before making changes in it.

If subsequent to modifying the kit, you have trouble and want to return it to Heath, then you must be prepared to remove the modifications I shall be describing. On the other hand, I'm prepared to give assistance to any *Audio Amateur* reader who may write to me in care of the magazine.

How these oscillators work

The IG-18, in common with most audio signal generators in use today, is a resistance/capacitance (RC) type, which means the frequency of oscillation is determined by sharply frequency selective resistance/capacitance networks. Sometimes, the networks are in the bridge form, as in the so-called Wein bridge oscillators; or, as in the case of the IG-18, the frequency determining elements are in a "bridged T" configuration.

This network type simulates a broadly tuned resonant circuit, and in the IG-18 is inserted in the degenerative, or negative feedback path of a high gain amplifier. Negative feedback is at a maximum, except at its "notch" frequency--so if oscillation occurs, it can only be at this frequency. So by simply altering the values of R or C, the frequency of oscillation is determined very accurately, to a tolerance defined by the accuracy of the bridge components. What small errors that do occur, could be caused by phase shifts within the amplifier; so this must be designed carefully and have a bandwidth well beyond the generator's frequency coverage.

The operational amp and loops

Heath's designers have come up with what is essentially, a very high gain operational amplifier, with low output impedance and two inputs, non-inverting and inverting. The RC bridge is in the inverting (or degenerative) path; the non-inverting path is the main regenerative loop and is also the amplitude controlling network. (See Fig.1)

I should explain at this point, that because of the low "Q" of RC tuned networks, it is essential to include them in an active filter configuration to insure low harmon-

ic generation in an oscillator of this type. It is highly desirable that the forward amplifying path should be as high gain as possible, but at all times, irrespective of the insertion losses of the frequency determining networks, the closed loop gain should be just above unity.

The positive loop has in it a positive temperature coefficient thermistor so as the amplitude of oscillations rises, it heats, resistance increases and the +ve feedback is reduced, thereby closely controlling the closed loop gain at all frequency control element settings.

Checkout before modification

As it stands, the IG-18 checked out well on this count. Over the entire range 1 Hz up to 100kHz it met their specification of ± 1 dB variation. Distortion wasn't quite as good as specified, typically around 0.12 to 0.14%, rising appreciably at the ends of the spectrum. Harmonic products were a disconcerting mixture of mainly second, third, and higher orders. Hum also contributed to the residue when the products were checked on an oscilloscope.

Accuracy was poor at some points and while even the $\pm 5\%$ isn't too wonderful for a decade instrument, at some scale settings the IG-18 was 12% out! Finally, the meter drove me mad at frequencies below 10Hz, when it started to read indi-

vidual half cycles in wild needle oscillations, becoming virtually useless in these ranges.

Modifications: first step

I decided, first of all, to deal with the serious blemishes--the frequency inaccuracies. This turned out to be an error in assembling the kit--very rare for Heath, in my experience. Heath improved the IG-18 over its ancestor, the IG-72 by providing a continuously variable third significant figure, a most useful feature when one is checking resonant circuits. The change virtually removes the major disadvantage of a switched decade type instrument.

Unfortunately, the design requires the extra resistive element to be switched out altogether when in the "0" position. The ordinary-ganged potentiometer used made it impossible to achieve this condition. So when the resistive components in the bridge were relatively high in value, an error of up to 10% was inevitable.

What Heath should have used was a rheostat. After their attention had been drawn to this, I was assured the error has been corrected. But if you have made the kit already or will be getting one, it is a wise precaution to check that this component--a 1 megohm ganged control, R_2 in the Heath schematic--does go open circuit when in its zero or fully anticlockwise position. (See Fig. 2.)

Step two. One other small layout error Heath has also accepted, and corrected, was giving rise to excessive crosstalk between the square and sine wave outputs. All that was necessary, was to shift a common ground return for the sine and square output attenuator sections. The one for the square wave section is now separate and an extra wire is taken from the attenuator direct to the ground line on the wave generator etched circuit board. All Heath's manuals subsequent to Dec. 5, 1969 are amended. You'll find the date of issue on the front cover, bottom right.

FIG.2

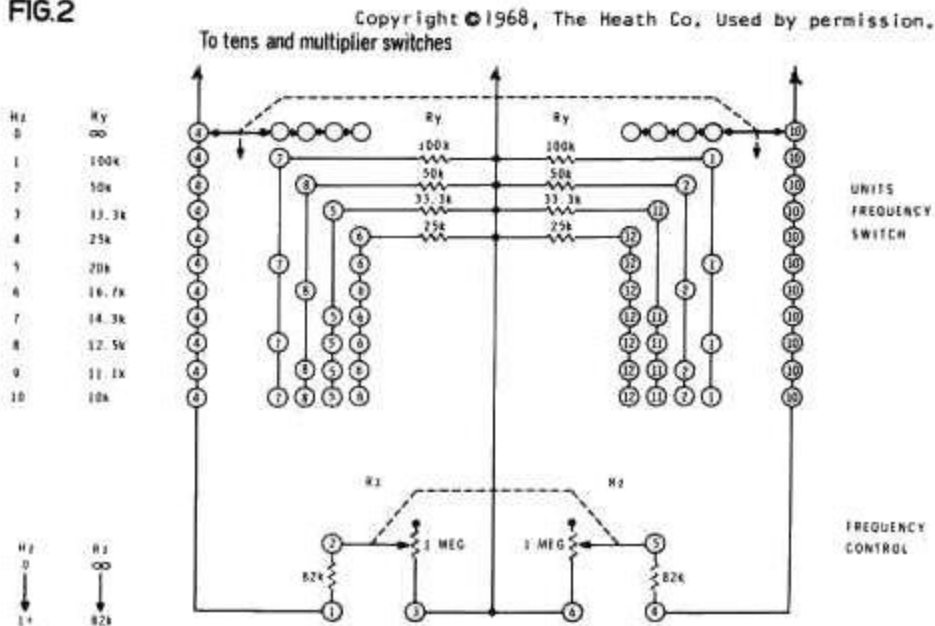

FIG.2. Heath designers added a variable rheostat to the three switches of the oscillator. The dual 1M Ω R_2 goes open circuit in its minimum position. Author Williamson says the unit works better if the 82K Ω resistors which Heath supplies to go across the rheostat's terminals are replaced with 100K Ω units. The control adds a variable one cycle to whatever frequency the network's three switches produce.

MODIFICATION PARTS LIST

Step one:

- 1 Dual 1M Ω linear rheostat
(Check your kit before ordering)
- 2 100k Ω , $\pm 2\%$ $\frac{1}{2}$ W. resistors

Step two:

- One short length of hookup wire

Step three:

- 1 6.8 μ F @ 30V bead tantalum capacitor

Step four:

- 1 100 μ F @ 6V electrolytic cap.

Step five:

- 1 47K Ω $\frac{1}{2}$ W resistor $\pm 5\%$
- 1 10K Ω $\frac{1}{2}$ W resistor $\pm 5\%$
- 1 1M Ω $\frac{1}{2}$ W resistor $\pm 5\%$
- 1 10 μ F @ 16V Electrolytic cap.
- 1 100 μ F @ 16V Electrolytic cap.
- 1 40408 transistor (RCA)

Step six:

- 2 1000 μ F @ 64V Electrolytic cap.

Step seven:

- 1 5.6K Ω $\frac{1}{2}$ W resistor $\pm 5\%$
- 1 250 μ F @ 6V Electrolytic cap.
- 1 Germanium diode (1N34, 1N91)

Step eight:

- 1 2N5087 (Mot) transistor
- 1 220K Ω $\frac{1}{2}$ W resistor $\pm 5\%$

Step nine:

- 1 40361 (RCA) transistor (Q4)
- 1 40362 (RCA) transistor (Q5)

Step ten:

- 1 47K $\frac{1}{2}$ W resistor $\pm 5\%$

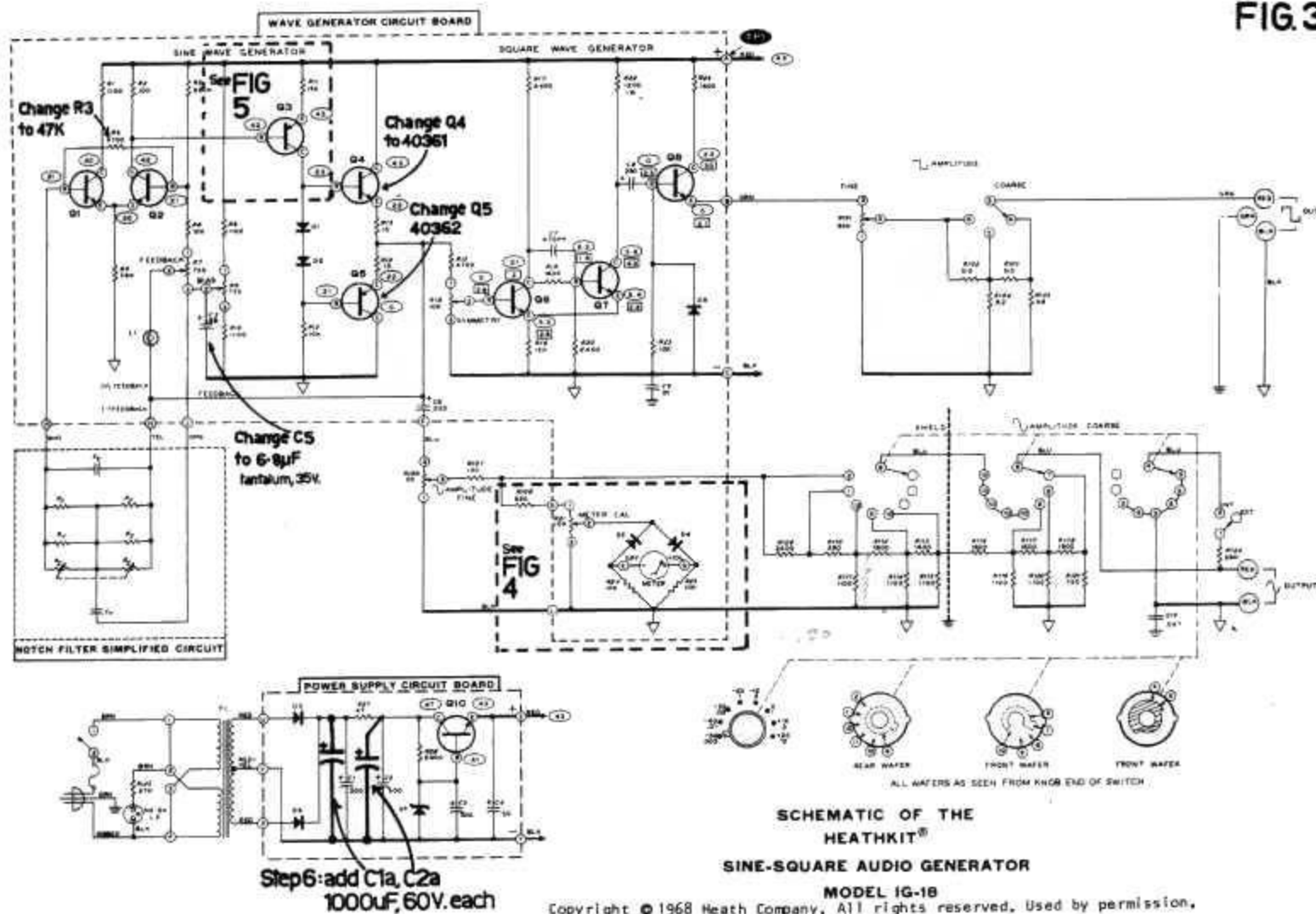

SCHEMATIC OF THE
HEATHKIT®
SINE-SQUARE AUDIO GENERATOR

MODEL IG-18

Copyright © 1968 Heath Company. All rights reserved. Used by permission.

Amplifier attacked

These changes move frequency accuracy to within specification. The actual check-out on a laboratory counter measures 0 to +3%; quite good, of course, but--well, for a switched generator it could be a lot better. At this stage, having got my review out of the way, I felt more and more convinced the IG-18 could be much improved. I needed a really accurate, low distortion generator for my own use anyway.

My original, also one of my own designs, was getting a little ancient and its accuracy a little wayward. A bright and sunny English Sunday, late in the summer, therefore, found me sitting in my den surrounded by frequency counter, distortion measuring set capable of reading distortion products down to 0.001%, oscilloscope and sundry other bits and pieces of test gear.

Step three. I made my first attack upon the amplifier section of the sine wave generator (See Fig. 3), since the harmonic content of the generated waveform was closely dependent upon the open loop gain. I first decided to increase the value

of a bypass capacitor in the base bias circuit for Q2 of the differential input stage. Heath themselves seemed to have had a bit of a problem deciding on the value for this capacitor, which goes to the ground line from the slider of R9. The etched circuit board diagram indicates it should be a 0.005 μ F, whereas a slip in my manual said 0.68 μ F, which is what was supplied.

My calculations indicated both were wrong. I had a hunch that in fact it should be a 6.8 μ F. So I fitted a bead tantalum type (not less than 30V. rating) and got the first big improvement. Accuracy was now within $\pm 0.5\%$ over the entire range and total harmonic distortion dropped to below 0.1% over nearly all the range.

Step four. With the bit now well between my teeth, I decided to attempt to further increase the forward gain of the amplifier stage. I added a 100 μ F (6V.) bypass capacitor across the emitter resistor of Q3 (R11) on the underside of the etched circuit board.

Modified metering

By now, however, I noticed the dis-

ortion was very dependent upon the setting of the "Amplitude Fine" control, with high order products predominant. The reason for this was obvious, the loading of the meter circuit and the nonlinear action of the diodes. The only answer was a buffer amplifier and this is the only major modification.

Step five. The added circuit, Fig. 4, is a simple emitter follower, quite easily made up on perforated board which can be suspended below the etched circuit board of the sine generator. The transistor I used isn't too critical, so long as it has a V_{ce0} rating greater than 45. I used an RCA 40408. This left the distortion products quite clean and mainly low order.

Step six. At this point, the level of harmonics were getting difficult to read because of hum and noise, so the power section was improved by the simple addition of extra smoothing prior to the regulator. I added two capacitors, 1,000 μ F. each, 60V. working, across the existing C1 and C2 (see Fig. 3), soldering them directly across the power supply etched circuit board.

--Continued overleaf

Step 7--Damping some waggles

Before leaving the meter circuit, I decided to do something about the poorly damped movement and added a low voltage working, 250 μ F. capacitor across the meter terminals. The meter action linearity also left a little to be desired, due to the nonlinearity of the rectifiers, D3 and D4. This was corrected by adding a 5.6K resistor and a germanium diode across the meter terminals as well. Almost any small diode will do, provided it is a germanium type.

Take care in adding the diode and capacitor to connect the proper polarities according to Fig. 4. This tightens up the meter accuracy, incidentally, to within $\pm 2\%$ as against Heath's specified $\pm 5\%$. The meter now reads without that violent needle waggle that irritated me so much, down to 1 Hz where the fluctuation in reading is less than ± 1 dB.

Step eight. I increased the current gain of Q3 by converting it into a compound pair, i.e. adding another transistor. The additional transistor, Q3a, shown in Fig. 5, should be a high h_{fe} , low noise device with a V_{ce0} of not less than 45V, and must, of course, be a pnp. One has a variety to choose from and I used a Motorola 2N5087.

You'll find it quite easy to add the extra transistor, Q3a to Q3. Just unsolder Q3's base lead (with a heat sink attached) and then lift it up out of the hole in the board. Bend this up in a "U" shape. Push the base lead of the Q3a transistor through this hole, and solder.

The collector lead of Q3a should be put through the same hole as that of the original Q3's collector, and also soldered. Now join the base lead of Q3 to the emitter lead of Q3a, along with one end of a 220k resistor. The other end of this resistor goes to a convenient +ve(B+) point on the etched circuit board. I found it a good idea to drill a small hole (#58 drill) near the +ve end of R11 and solder the 220k to the same section of the copper laminate.

Step nine. I changed the output transistors, Q4 and Q5 to larger chip types, substituting the most inexpensive available: an RCA 40361 for Q4, and RCA's 40362 for Q5. (See Fig. 3.)

Step ten. Change R3 in the differential input from its original value of 4.7k Ω to 47k Ω .

The new specifications

These are about all the modifications any home constructor is able to do. The oscillator should now be

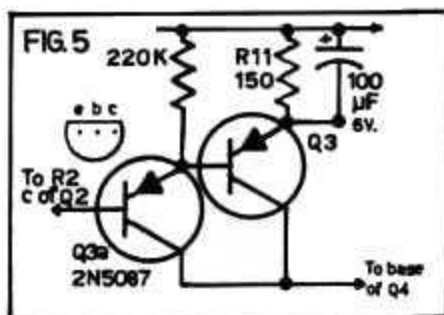

FIG. 5. Details of adding a transistor to Q3 to make it a compound pair. See text.



FIG. 6. Rise time of the square wave section of the IG-18. Distance between graticule divisions = 0.1 μ sec. The author says the tiny ring at the top is test lead inductance.

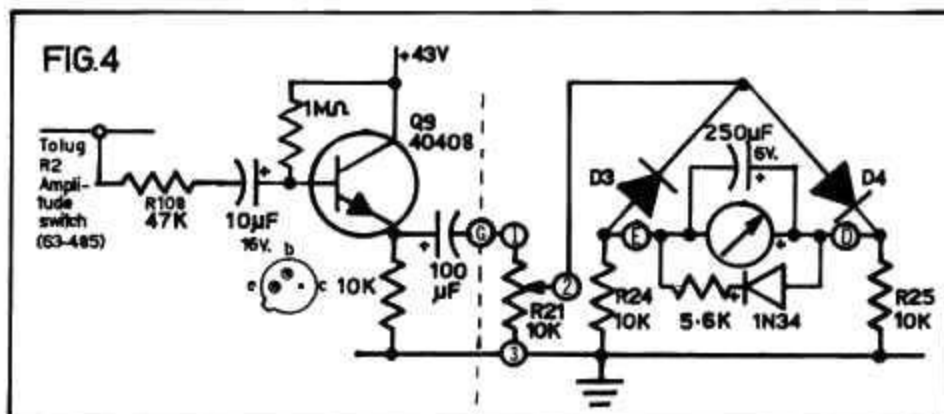

FIG. 4. Additional circuitry for isolating the meter from the oscillator's amplifier and for damping low frequency oscillations in meter reading.

set up in accordance with the instructions on manual pages 41 through 43. Please keep one minor point in mind. The adjustment of the feedback control, R7, is now going to be rather sharp, and hence a little more difficult to set. Also, when adjusting the bias control, R9, have the feedback control set to the point where clipping is just noticeable on the -ve and +ve half cycles of the waveform. You will achieve the best results by setting the bias so these clipping points are as symmetrical as possible.

Now, after doing all this, what are the results? You may rest assured, performance of your IG-18 will now be up to laboratory standard. The distortion products of my unit are typically 0.003%, with noise contributing an equal amount so that the total is always less than 0.01%. Accuracy, as I said earlier is $\pm 0.5\%$ as the instrument stands. If you can get the use of a digital counter, you could do as I have and with a little bridge circuit padding here and there, get it as close as 0.2%.

Getting the best out

Because of the circuit design, the unit will perform best when the

"Coarse Amplitude" control is in its highest position, permitting appreciable attenuation with the "Fine" control. You will get minimum noise products whenever you can use the "Tens" frequency switch, also. The nature of the distortion products is now much more clearly defined and almost pure second harmonic--ideal for amplifier measurements.

So far, I have said nothing about the square wave section. I do not need to. Heath have undersold themselves here, because it is way, way better than their modest claim of a 50 nanosecond rise time. I checked this on a Tektronix oscilloscope which has an inherent rise time on its vertical amplifiers of 12 nanoseconds. My 'scope picture (see Fig. 7) shows it is at least equal, if not very much better than this--so absolutely no changes are necessary.

Now I wonder if Heath might be thinking of updating their Harmonic Distortion Analyzer?

[While we have no inside information from Benton Harbor, we do have a modification of Heath's IM-58 in the works for publication soon. Tape buffs will be particularly interested.--Ed.]