

# ASSEMBLY AND OPERATION OF THE HEATHKIT SINGLE SIDEBAND ADAPTER MODEL SB-10

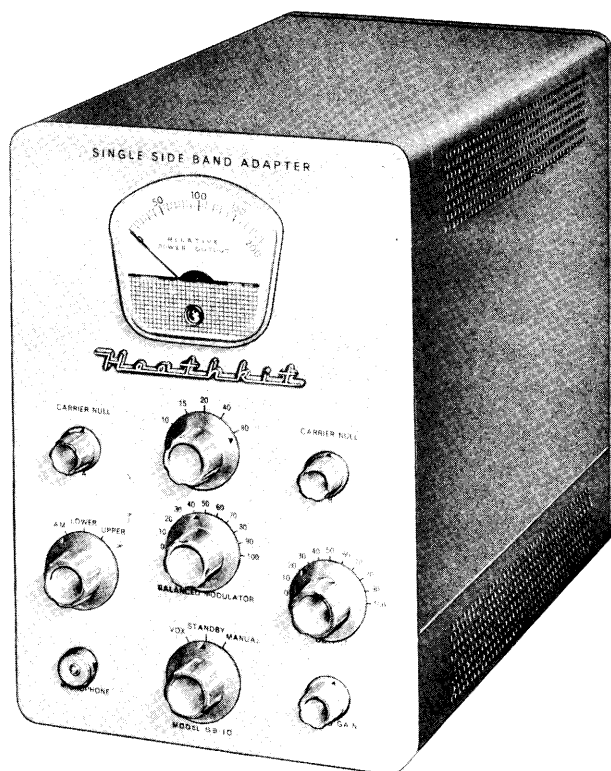

## SPECIFICATIONS

Power Output:.....	10 watts, P. E. P. (peak envelope power)
Excitation Requirements:.....	Less than 3 watts of RF at the fundamental operating frequency required.
Output:.....	Pi network coupling to low impedance coaxial line.
Input:.....	Low impedance for coaxial line feed.
Band Coverage:.....	80, 40, 20, 15, 10 meters.
Circuitry:.....	Phasing method of SSB signal generation is employed with voice control and anti-trip action built into the audio circuit.
Tube Complement:.....	1 - EL84/6BQ5 RF output 1 - 6CL6 RF driver 2 - 12AT7 balanced modulators 1 - 12AX7 speech amplifier 1 - 12AT7 modulator 1 - 12AT7 voice control and anti-trip amplifier 1 - 12AT7 audio driver and relay control 1 - 6AL5 voice control and anti-trip bias rectifier



Unwanted Sideband Suppression:.....	In excess of 30 db.
Carrier Suppression:.....	In excess of 40 db.
Power Requirements:.....	350 VDC, 85 MA (Average) 30 MA (Standby) 140 MA (Transmit) 6.3 VAC, 3.5 AMP
Meter:.....	2 1/2", 200 ua movement, indicates carrier null and relative power output.
Cabinet:.....	10" high, 6 3/4" wide, 13" deep.
Net Weight:.....	10 lbs.
Shipping Weight:.....	14 lbs.

### INTRODUCTION

The SB-10 is designed specifically as a matching accessory unit to the Heathkit "Apache" Model TX-1 Transmitter to provide a capability for SSB operation on the 80, 40, 20, 15, and 10 meter amateur bands. While the SB-10 can be plugged directly into the "Apache", with slight modifications it can be used with the Heathkit DX-100 and DX-100B transmitters. The primary feature of the SB-10 is that it allows utilization of all RF circuitry in the companion transmitter, thus making use of the operator's investment in AM gear and enabling him to retain his high level AM capability. This feature brings the cost of an SSB capability within the budget of all amateurs and will afford them the opportunity to experience the advantages of SSB operation.

The SB-10 obtains power from the companion transmitter. It features a built-in electronic voice control with anti-trip circuitry to prevent the receiver audio output from keying the transmitter during listening periods. A sensitive tuning meter is provided for accurate carrier null and indication of relative power output. Panel controls include the bandswitch, balanced modulator and output tuning, two carrier null controls, sideband selector (upper, lower, AM), function switch (VOX, standby, manual), audio gain, and the microphone connector. Two controls on the rear apron provide VOX and anti-trip sensitivity adjustment. Relay contacts are provided for receiver muting, keying the exciter stages of the transmitter, and operating an antenna relay. The power plug plus the input and output connectors are also located on the rear apron.

Before proceeding with the circuit description of the SB-10, it may be desirable to explain the nature of an SSB signal, give a brief history, and discuss the advantages of SSB operation plus methods of generating a SSB signal.

The normal 100% amplitude modulated RF carrier presents a frequency spectrum like that shown in Figure 1.

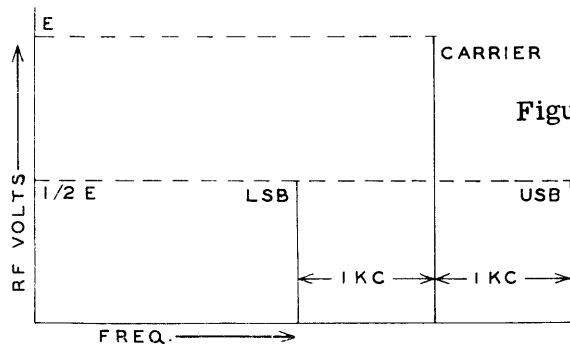

Figure 1

For illustrative purposes, we will assume that the modulation consists of a single tone. Speech modulation, of course, will produce side frequencies occupying identical bands on the upper and lower sides of the carrier; thus the term sidebands. The carrier itself conveys no intelligence; all intelligence is contained in the sidebands. Furthermore, since the lower and upper sidebands are identical, one sideband can also be eliminated leaving only that part of the signal necessary to convey intelligence, a single sideband. The carrier can be re-inserted at the receiver for demodulation purposes, thus completing the picture. What is gained by this process?

First, for a given amplifier peak power rating, by eliminating the carrier, we can double the amplitude of each sideband. This increases the total sideband power  $(1+1)^2$  or 4 times. Referring to Figure 1, it is apparent that each sideband of a 100% amplitude modulated carrier is one half the amplitude of the carrier or, squaring once again, 1/4 the carrier power. Total sideband power is  $1/4 + 1/4$ , or 1/2 the carrier power. Notice that the peak power rating of the 100% amplitude modulated amplifier is equal to the power at the instant all the voltage elements of Figure 1 add. This is equal to  $(2)^2$  or 4 times the carrier power. Thus, by further eliminating one of the two sidebands, we can double the total sideband power once again and still not overload the amplifier on peaks ( $4 \times 2 \times 1/2$  carrier power = 4 x carrier power). Since the total sideband power is multiplied 8 times, an increase in "talk-power" of 9 db is realized.

Second, by eliminating the carrier, we eliminate the QRM caused by carrier heterodynes.

Third, spectrum space is conserved since only half of the original AM spectrum is required. This also enables the operator to cut his receiver bandwidth in half, further reducing exposure to QRM.

SSB operation presents two primary obstacles, one physical and the other psychological. Stable oscillators for transmitting frequency control and carrier insertion at the receiver are a prime requisite. This problem can be overcome by proper design and has been solved by the manufacturers of receivers and SSB transmitting equipment producing for today's market. The supposed complexity of SSB equipment is the psychological obstacle. However, there is nothing about SSB circuit theory and equipment that cannot be easily grasped by the average amateur after a little study of the numerous articles and books published on the subject. Most of the basic circuits are familiar and only vary in their application. The initial investment in SSB equipment for low power will be somewhat more than for comparable power AM equipment. Despite this, more effective communication will be realized with the SSB equipment at the same power level. Furthermore, the investment required to go to higher power will always be considerably lower for SSB equipment since no high level modulation equipment is necessary.

The principles involved in SSB transmission have been known for many years, but the lack of commercially available sharp cutoff filters, high stability crystals, and audio phase shift networks restricted SSB application to relatively few fields, primarily long distance telephone work. However, with the radio frequency spectrum becoming more and more crowded, some services began to use SSB as a means of conserving available space. The military led the way to more widespread use of SSB. The FCC then began to order other services to convert to SSB and the ensuing transition in recent years has not only stirred up significant amateur interest but also brought about the commercial availability of components for SSB equipment at reasonable prices.

Two methods of generating an SSB signal are commonly employed in amateur equipment. One method employs very sharp filters of either the LC, crystal or mechanical type to pass one sideband and suppress the other. These filters exhibit best characteristics at lower frequencies. Therefore, filter type SSB transmitters employ heterodyne methods of converting the low SSB frequency to the desired band. The filtering method has the advantage that frequency stability is easier to obtain at lower frequencies. Its one disadvantage is complex filter design and adjustment plus somewhat higher cost. Carrier suppression is obtained through the use of a balanced modulator.

The phasing method of SSB signal generation is more complex in theory than filtering, but has the distinct advantages of lower cost, easier adjustments, plus equally good performance at all frequencies. Since the phasing method is employed in the SB-10 it will be explained in some detail.

The phasing method of generating a single sideband signal can best be explained using two simple vector diagrams and then referring to a simplified schematic diagram to see how the method is practically applied.

Before proceeding, it may be advisable to become re-acquainted with vector algebra. Quantities which represent magnitude only, such as inches, cubic feet, or degrees, are called scalar quantities and can be represented merely by numbers. However, quantities which represent

both magnitude and direction, such as force or alternating voltage, are called vector quantities and are usually represented by vector diagrams. In vector diagrams, the length of the vector indicates its magnitude, and the vector's angular displacement from some reference point indicates its direction. In referring to vector diagrams of alternating voltage, remember that time is frozen for the instant of observation since, when dealing with cyclic waveforms, the vector, in actuality, would be rotating at a rate equal to one full  $360^\circ$  revolution per cyclic period.

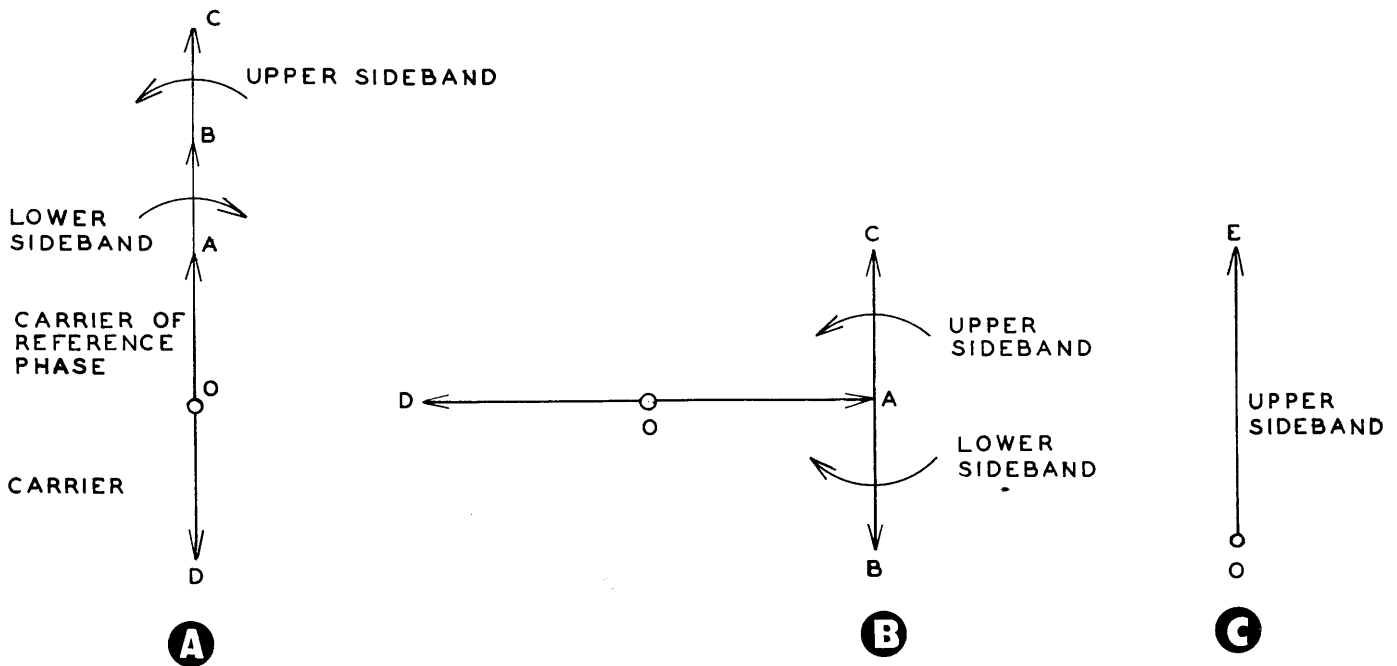

Figure 2

Referring to Figure 2, suppose a carrier of reference phase OA is fed to two "black boxes" where it is modulated and operated upon until the output of "black box A" can be represented by the entire vector diagram A, and the output of "black box B" can be represented by the entire vector diagram B. Diagram A represents the reference carrier, modulated with a reference tone, plus another carrier component equal in magnitude and  $180^\circ$  out of phase. Diagram B represents a carrier equal in magnitude to the reference carrier but displaced  $90^\circ$ , plus another carrier component equal in magnitude and  $180^\circ$  out of phase. The diagram further indicates that the displaced carrier is modulated by a tone displaced  $90^\circ$  from the reference modulating tone. By simple vector addition of both diagrams, it can be seen in Diagram C that all carrier voltage is cancelled out along with the lower sideband, while the upper sideband reinforces to become twice its original magnitude. Thus, the phasing method of SSB signal generation requires circuitry to provide  $90^\circ$  carrier phase shift,  $90^\circ$  audio phase shift, and carrier suppression.

In actual practice, each "black box" referred to above contains a balanced modulator and a  $45^\circ$  carrier phase shift network, while the  $90^\circ$  audio phase shift is accomplished externally before application. Referring to Figure 3 on page 6, the incoming RF is split into two components by the two  $R_1 C_1$  passive phase shift networks, one leading the incoming signal by  $45^\circ$ , the other lagging by  $45^\circ$ . The net result is the required phase difference in the RF input to the two balanced modulators  $V_1 V_2$  and  $V_3 V_4$  of  $90^\circ$ . The audio signal is fed to an RC network whose two outputs have a difference in phase of  $90^\circ$  over the frequency range of speech. By applying these two outputs to  $T_1$  and  $T_2$ , two modulating voltages  $180^\circ$  out of phase with each other can be applied to balanced modulator  $V_1 V_2$  and another two  $180^\circ$  out-of-phase modulating voltages can be applied to balanced modulators  $V_3 V_4$ . The  $180^\circ$  out-of-phase voltages are required for proper modulation of a balanced modulator. However, the net phase differences applied to each balanced modulator is only  $90^\circ$ .

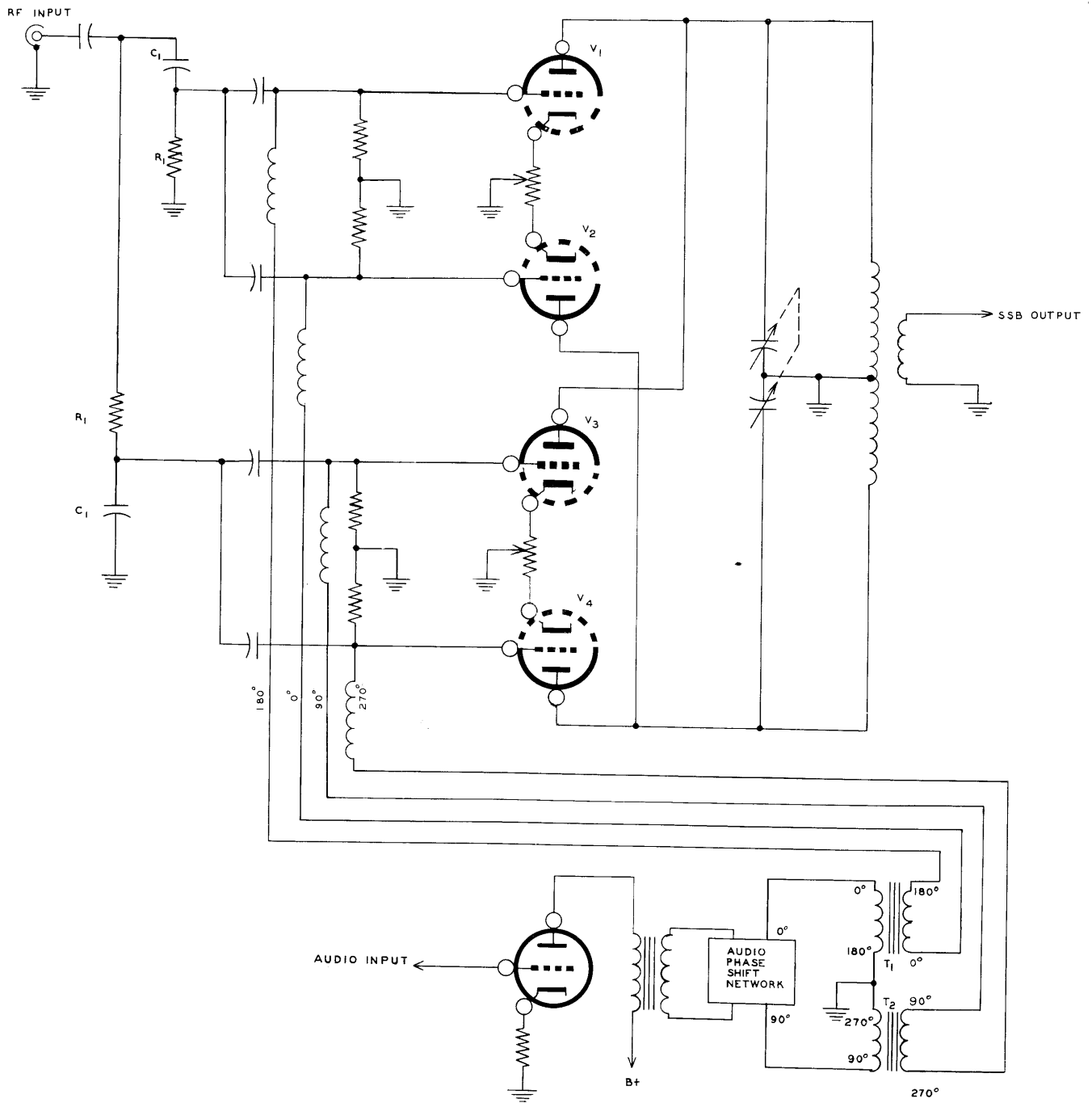

Figure 3

A balanced modulator is normally employed to suppress the carrier. A single balanced modulator can be designed to balance out either or both input signals but cannot balance out one sideband and not the other. Hence, the necessity for two balanced modulators, as used here, with output circuits connected in push-pull-parallel. With the RF inputs to  $V_1$  and  $V_2$  in parallel and the outputs of  $V_1$  and  $V_2$  in push-pull, the carrier is split into two components in the output circuit, each equal but  $180^\circ$  out of phase with each other. Since the same configuration exists in  $V_3$  and  $V_4$ , the carrier is balanced out in each modulator. Thus, with all conditions satisfied ( $90^\circ$  phase difference between both RF and audio inputs to each of the balanced modulators and the carrier suppressed), the result is a single sideband output signal.

## CIRCUIT DESCRIPTION

The following block diagram and circuit description will show the builder how the theory of the phasing method has been practically applied in the SB-10 and will result in an even better understanding of the adapter. This knowledge will aid in construction and possible trouble shooting, and thus is well worth digesting.

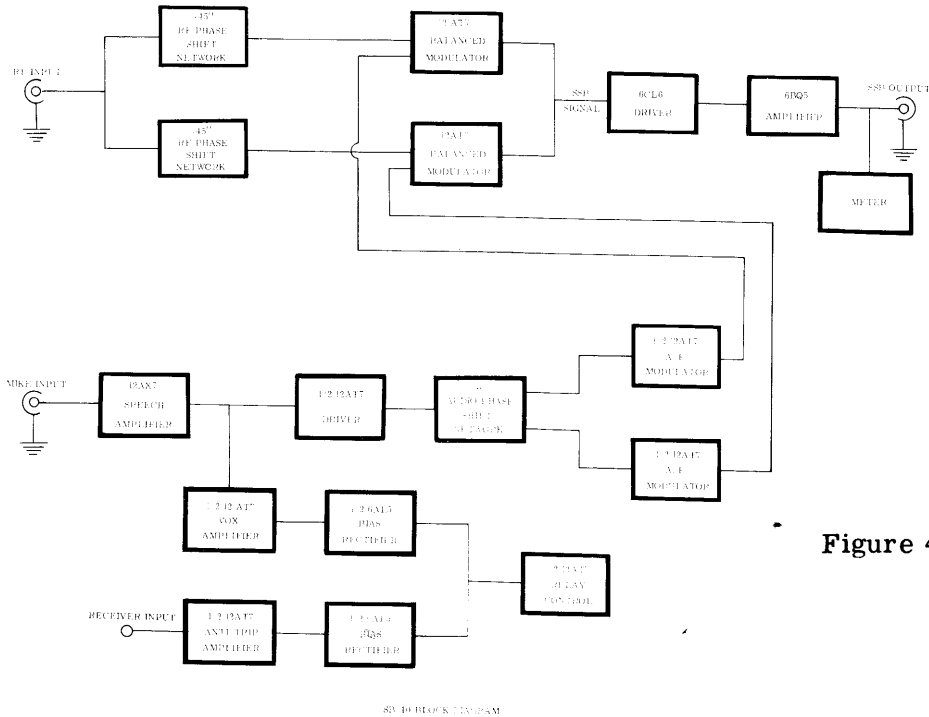

Figure 4

### AUDIO AND PHASING CIRCUITRY

The 12AX7 dual triode tube provides two stages of resistance coupled speech amplification with sufficient gain for a high impedance microphone input. The design of the speech amplifier circuitry favors an audio frequency range of from 300 to 3000 cycles per second. The output of the speech amplifier is capacitively coupled through a gain control to one section of a 12A7 acting as an audio driver. The output of the driver is transformer coupled to the low impedance side of a 90° audio phase shift network which is designed to operate over the audio range of 300 to 3000 cycles per second. By restricting the audio frequencies to the stated limits, errors in the 90° phase shift network, which will directly impair the suppression of the unwanted sideband, are minimized.

A control, known as the phase balance control, is connected across the low impedance (500 ohms) side of the interstage transformer which feeds the passive network. The function of the control is balancing the input circuit to the network.

The output of the phase shift network is of a relatively high impedance and is connected to the two grids of a dual triode 12A7 tube. This tube functions as the modulator.

The cathodes of the 12A7 modulator are biased with a variable and fixed resistor configuration. The purpose of the control is for audio balance. This tube must deliver equal output to the primary of each of the two modulation transformers.

### VOICE CONTROL AND ANTI-TRIP CIRCUITRY

The output of the speech amplifier is also capacitively coupled to one section of a dual triode 12A7 tube acting as the vox voltage amplifier. The other half of the 12A7 tube acts as the anti-trip amplifier and receives and amplifies the receiver output, which is transformer coupled to the grid.

The output of the vox voltage amplifier is capacitively coupled to the plate of one section of a 6AL5 dual diode and the output of the anti-trip voltage amplifier is capacitively coupled to the cathode of the second 6AL5 diode.

The audio output alternating current voltage which is developed in the anti-trip voltage amplifier is then rectified and appears as a negative potential at the plate of the other 6AL5 diode. The diode will not conduct when so biased. Therefore, the relay control tube (1/2 of a 12AT7) remains cut-off by the fixed bias applied to the cathode by the voltage divider network.

From this "Anti-Trip" action, it can be seen that for the relay to be tripped, it will be necessary to upset the negative voltage at the plate of the diode, thus allowing it to conduct and place sufficient positive voltage on the grid of the relay control tube to overcome the fixed cutoff cathode bias. This positive "upsetting" voltage is developed in the speech and vox amplifier stages and originates at the microphone. Thus, with proper setting of the sensitivity controls, speaking into the microphone trips the relay by overcoming the receiver anti-trip bias, but receiver audio entering the microphone will not trip the relay due to "in phase bias" developed by the anti-trip circuit.

A capacitor resistor network charges and discharges across the grid of the control tube to introduce the necessary time delay after speech is discontinued.

A cathode bias voltage divider network on the relay control tube is switched in or out for a selection of voice control or manual operation. In standby position, B+ is removed from all circuits.

#### BALANCED MODULATOR CIRCUITRY

The input circuit to the pair of balanced modulators consists of a broadband RF Phase Shift network of the passive type. An entirely different network to provide the proper phase shift at each fundamental input frequency is switched in on each band. This design feature permits operation on all frequencies in the particular band desired without the necessity of continual adjustment, but still maintains a very high degree of precision in the RF Phase Shift network. The network is capacitively coupled to the balanced modulator grids. The cathodes of the balanced modulators are returned to ground through 1000 $\Omega$  tube balancing or carrier null controls which are adjusted from the front panel. The plates of the tubes are tuned to the operating frequency with a multiband coil and capacitor circuit.

The modulation voltage developed in the AF modulator is coupled through two 1:1 ratio transformers to the balanced modulator grids. A sideband selector switch is connected in the output leads of the transformers which applies the audio voltage in the proper phase relationships to obtain upper, lower, or double sideband (AM) operation. The RF voltage is isolated from the audio network by the use of four 500 microhenry chokes to couple the audio to the grids of the balanced modulators.

#### DRIVER AND RF AMPLIFIER CIRCUITRY

A 6CL6 tube is employed as a Class A driver stage. The excellent linear capabilities of the 6CL6 as a Class A amplifier lends itself perfectly to this application. The grid of the 6CL6 is coupled through a capacitor to a link on the balanced modulator output coil. Bandswitch selected, broadband, slug tuned coils are used for tuning the driver output circuit.

The output circuit of the driver stage is coupled to the grid of the 6BQ5 tube. This stage is also operating in Class A service and is easily driven to maximum output while maintaining excellent linearity.

The plate circuit is shunt fed and couples to an all-band Pi network output circuit. The plate circuit also furnishes a sample of RF voltage to operate the meter for the purpose of tuning the adapter.



## NOTES ON ASSEMBLY

Try to provide a work area that will not have to be cleared or disturbed if your work should be interrupted. It is much easier to resume construction if everything can remain in its place until completion of the kit. Provide yourself with good quality tools as the use of improper or inferior tools will cause your workmanship to suffer and result in longer assembly time. There is also a great deal of personal satisfaction in a neat professional looking adapter, resulting from careful assembly and wiring. Basic tool requirements consist of a screwdriver with a 1/4" blade; a small screwdriver with a 1/8" blade for setscrews and adjustments; long nose pliers used to form leads and hold parts; wire cutters, preferably separate diagonal cutters; a penknife, or preferably a tool for stripping insulation from wires; a soldering iron or gun and rosin core radio solder. Be sure to read the paragraphs on soldering before you start wiring the adapter. **UNPACK THE KIT CAREFULLY AND CHECK EACH PART AGAINST THE PARTS LIST.** In so doing, you will become acquainted with each part. Refer to the charts and other information shown on the inside covers of the Manual to help you identify any parts about which there may be a question. If some shortage is found in checking the parts, please notify us promptly and return the inspection slip with your letter to us. Hardware items are counted by weight and if a few are missing, please obtain them locally if at all possible to avoid delay in the construction of your kit.

Resistors and controls generally have a tolerance rating of  $\pm 20\%$  unless otherwise stated in the Parts List, therefore, a 1 K $\Omega$  resistor may test anywhere from 800 $\Omega$  to 1200 $\Omega$  (the letter K is commonly used to designate a multiplier of 1000). Tolerances on capacitors are generally even greater. Limits of  $+100\%$  and  $-50\%$  are common for electrolytic capacitors. The parts furnished with your Heathkit have been specified so as to not adversely affect the operation of the finished instrument.

In order to expedite delivery to you, we are occasionally forced to make minor substitutions of parts. Such substitutions are carefully checked before they are approved and the parts supplied will work satisfactorily. By checking the Parts List for resistors, for example, you may find that a 1200 $\Omega$  resistor has been supplied in place of a 1 K $\Omega$  as shown in the Parts List. These changes are self evident and are mentioned here only to prevent confusion in checking the contents of your kit.

Most kit builders find it helpful to separate the various parts into convenient categories. Muffin tins or molded egg cartons make convenient trays for small parts. Resistors and capacitors may be placed in the edge of a piece of corrugated cardboard until they are needed. Values can be written on the cardboard next to each component. The illustration shows one method that may be used. Read through the entire Manual before starting construction. In this way you will become familiar with the techniques employed in building the kit. As a further deterrent to errors, read each step of the construction and wiring completely before performing that step.

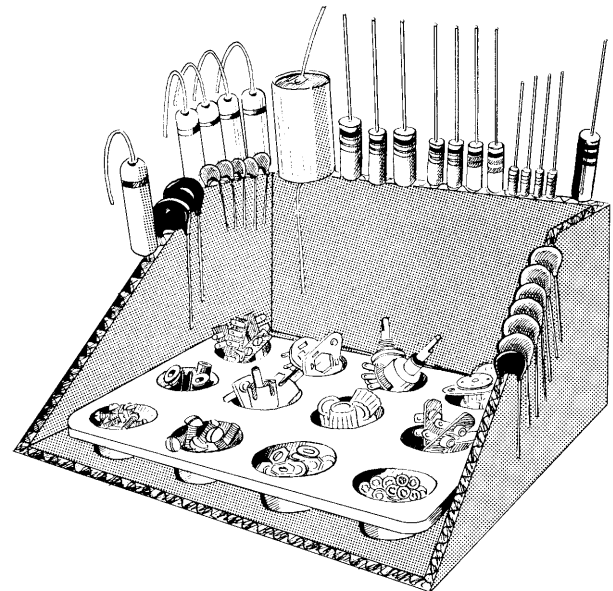

Do not try to hurry your work or to work for too long a period at one time. Both courses will lead to carelessness and increased possibility of error. The instructions and illustrations have been prepared to assist you in every detail during construction and use of your adapter. We urge you to follow them carefully and thus avoid improper operation or the possibility of damage to components through errors in construction. There is a great satisfaction in having your adapter work properly the first time you turn it on -- do not deny yourself this pleasure through careless work.

## PROPER SOLDERING PROCEDURE

Only a small percentage of Heathkit purchasers find it necessary to return an instrument for factory service. Of these, by far the largest proportion function improperly due to poor or improper soldering.

Correct soldering technique is extremely important. Good solder joints are essential if the performance engineered into the kit is to be fully realized. If you are a beginner with no experience in soldering, a half-hour's practice with odd lengths of wire and a tube socket will be a worthwhile investment.

High quality solder of the proper grade is most important. There are several different brands of solder on the market, each clearly marked "Rosin Core Radio Solder." Such solders consist of an alloy of tin and lead, usually in the proportion of 50:50. Minor variations exist in the mixture such as 40:60, 45:55, etc. with the first figure indicating the tin content. Radio solders are formed with one or more tubular holes through the center. These holes are filled with a rosin compound which acts as a flux or cleaning agent during the soldering operation.

NO SEPARATE FLUX OR PASTE OF ANY KIND SHOULD BE USED. We specifically caution against the use of so-called "non-corrosive" pastes. Such compounds, although not corrosive at room temperatures, will form residues when heated. The residue is deposited on surrounding surfaces and attracts moisture. The resulting compound is not only corrosive but actually destroys the insulation value of non-conductors. Dust and dirt will tend to accumulate on these "bridges" and eventually will create erratic or degraded performance of the instrument.

NOTE: ALL GUARANTEES ARE VOIDED AND WE WILL NOT REPAIR OR SERVICE INSTRUMENTS IN WHICH ACID CORE SOLDER OR PASTE FLUXES HAVE BEEN USED. WHEN IN DOUBT ABOUT SOLDER, IT IS RECOMMENDED THAT A NEW ROLL PLAINLY MARKED "ROSIN CORE RADIO SOLDER" BE PURCHASED.

If terminals are bright and clean and wires free of wax, frayed insulation and other foreign substances, no difficulty will be experienced in soldering. Crimp or otherwise secure the wire (or wires) to the terminal, so a good joint is made without relying on solder for physical strength. To make a good solder joint, the clean tip of the soldering iron should be placed against the joint to be soldered so that the terminal is heated sufficiently to melt solder. The solder is then placed against both the terminal and the tip of the iron and will immediately flow out over the joint. Refer to the sketch below. Use only enough solder to cover wires at the junction; it is not necessary to fill the entire hole in the terminal with solder. Excess solder may flow into tube socket contacts, ruining the socket, or it may creep into switch contacts and destroy their spring action. Position the work so that gravity tends to keep the solder where you want it.

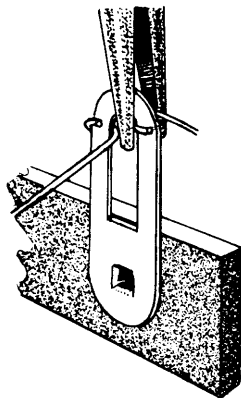

CRIMP WIRES

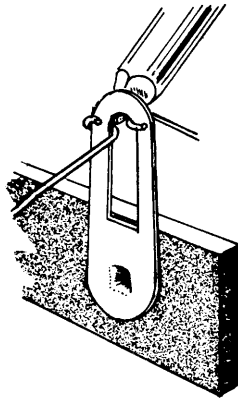

HEAT CONNECTION

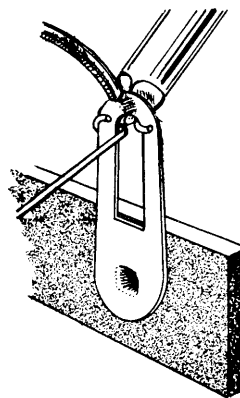

APPLY SOLDER

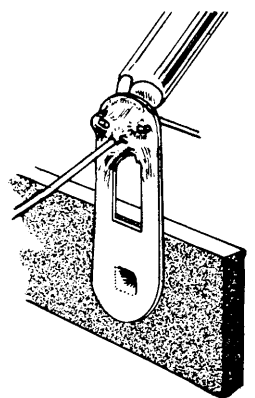

ALLOW SOLDER TO FLOW

A poor solder joint will usually be indicated by its appearance. The solder will stand up in a blob on top of the connection with no evidence of flowing out caused by actual "wetting" of the contact. A crystalline or grainy texture on the solder surface, caused by movement of the joint before it solidified is another evidence of a "cold" connection. In either event, reheat the joint until the solder flows smoothly over the entire junction, cooling to a smooth, bright appearance. Illustrations below clearly indicate these two characteristics.

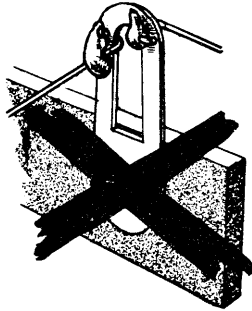

**COLD SOLDER JOINT  
CONNECTION INSUFFICIENTLY  
HEATED**

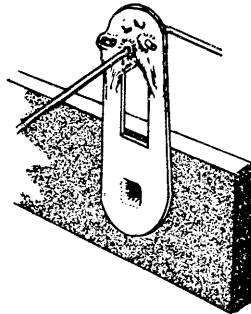

**PROPER SOLDER  
CONNECTION**

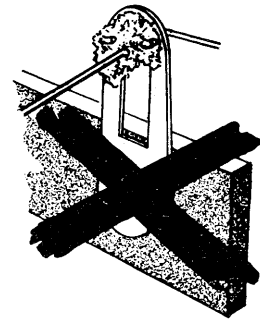

**COLD SOLDER JOINT  
CONNECTION MOVED  
WHILE COOLING**

A good, clean, well-tinned soldering iron is also important to obtain consistently perfect connections. For most wiring, a 60 or 100 watt iron, or the equivalent in a soldering gun, is very satisfactory. Smaller irons generally will not heat the connections enough to flow the solder smoothly over the joint and are recommended only for light work, such as on etched circuit boards, etc. Keep the iron tip clean and bright. A pad of steel wool may be used to wipe the tip occasionally during use.

Take these precautions and use reasonable care during assembly of the kit. This will insure the wonderful satisfaction of having the instrument operate perfectly the first time it is turned on.

#### NOTES ON WIRING

Read the notes on soldering and wiring on the inside rear cover. Crimp all leads tightly to the terminal before soldering. Be sure both the lead and terminal are free of wax, corrosion or other foreign substances. Use only the best rosin core solder, preferably a type containing the new activated fluxes such as Kester "Resin-Five", Ersin "Multicore" or similar types.

Unless otherwise indicated, all wire used is insulated. Wherever there is a possibility of the bare leads on resistors and capacitors shorting to other parts or to chassis, the leads should be covered with insulated sleeving. This is indicated in the instructions by the phrase "use sleeving". Bare wire is used where the lead lengths are short and the possibility of short circuits are non-existent.

Leads on resistors, capacitors and transformers are generally much longer than they need to be to make the indicated connections. In these cases, the excess leads should be cut off before the part is added to the chassis. In general, the leads should be just long enough to reach their terminating points. Not only does this make the wiring much neater but in many instances, the excessively long leads will actually interfere with proper operation of the instrument.

The pictorials indicate the actual chassis wiring and designate values of component parts. We very strongly urge that the chassis layout, lead placement and grounding connections be followed exactly as shown. While the arrangement shown is probably not the only satisfactory layout, it is the result of considerable experimentation and trial. A common factor of radio frequency equipment is the critical placement of leads and components. The lead dress shown in the pictorials should be followed carefully to insure the most stable, accurate and dependable operation of the adapter.

Space has been provided for you to check off each operation as it is completed. This is particularly important in wiring and it may prevent omissions or errors, especially where your work is interrupted frequently as the wiring progresses. Some kit builders have also found it helpful to mark each lead in colored pencil on the pictorial as it is added.

The abbreviation "NS" indicates that the connection should not be soldered as yet, for other wires will be added. When the last wire is installed, the terminal should be soldered and the abbreviation "S" is used to indicate this. Note that a number appears after each solder (S) instruction. This number indicates the number of leads connected to the terminal in question. For example, if the instructions read, "Connect a 47 K $\Omega$  resistor from socket E1 (S-2) to E6 (NS)", it will be understood that there will be two leads connected to the terminal at the time it is soldered. This additional check will help avoid errors.

We suggest you do the following before any work is started:

1. Attach the large fold-in pictorials to the wall above your work bench.
2. Review the assembly and wiring instructions. This is an excellent time to leaf through the entire instruction section and familiarize yourself with the procedure.
3. Lay out all parts so that they are readily available. Refer to the general information inside the front and back covers of this manual to help you identify components.

### STEP-BY-STEP ASSEMBLY

Due to the compactness of the SB-10, the physical design and layout was accomplished on a sectional, or sub-chassis, basis. The main chassis contains the audio, audio phasing, voice control, and anti-trip circuitry, and the four sub-chassis pieces are mounted on the main chassis after they have been wired. This provides easy access to all components during assembly, but the net result is a fairly compact yet easy to service unit. One sub-chassis contains the balanced modulator circuitry; a second, the RF circuitry; and the other two make up the front and rear aprons. Lead lengths given are liberal and any excess wire should be trimmed off, thus affording the most direct connection.

### ASSEMBLY AND WIRING OF THE AUDIO AND PHASING DECK

Mount all sockets and parts as detailed below. Observe carefully the orientation of the sockets as identified by the vacant pin space. Install terminal strips and solder lugs as instructed. To alleviate the necessity of repeating instructions in each step, use 1/4" 3-48 pan head machine screws, #3 lockwashers and 3-48 nuts for securing the miniature sockets. Install all terminal strips with their mounting feet between the lockwasher and nut. This practice affords a better connection to chassis. Refer to Pictorials 1 and 2 for the following steps.

- (✓) Select 10 each, 1/4" x 3-48 BHMS, #3 lockwashers and 3-48 nuts for mounting sockets.
- (✓) Install two 9 pin shielded phenolic miniature sockets at locations "A" and "C". Mount 3 lug terminal strips, one with a ground lug and the other without, as shown, at the ends nearest the chassis flange. Place a small #6 solder lug under the other mounting screw at "C". Orient as shown in Pictorial 1.
- (✓) Install a 7 pin miniature socket at "B". Secure a small #6 ground lug with the hardware at the end nearest the chassis flange.
- (✓) Install a 9 pin miniature socket at "D".
- (✓) Install a 9 pin miniature socket at "F" with a three lug, center ground terminal strip, mounted as shown in Pictorial 1.
- (✓) Install the mica octal socket at "E". Orient as shown in Pictorial 1. Use 6-32 RHMS, #6 lockwashers and #6-32 nuts.

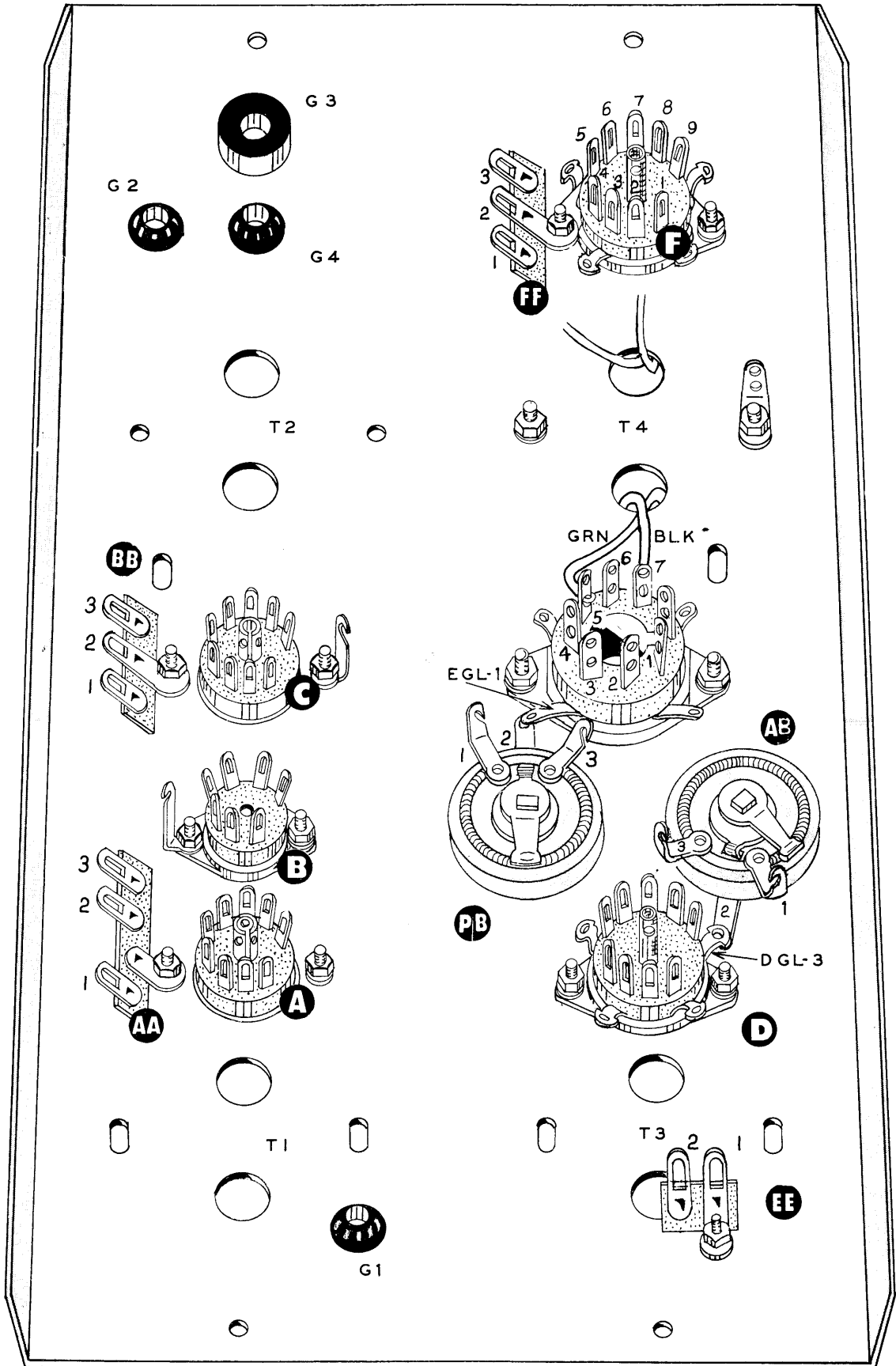

PICTORIAL 1

- (✓) Select the two, wire wound, screwdriver adjust controls. (Both are 500Ω controls and are used as phase and audio balance controls.)
- (✓) Install the phase balance control by placing a control lockwasher on the bushing and inserting it at "PB". Orient the control as shown in Pictorial 1. Secure with a nickel panel washer and a control nut.
- (✓) Install the audio balance control at "AB" in like manner.

NOTE: In denoting socket ground lugs, the socket is identified by the first letter, the "GL" is the abbreviation for "ground lug". As an example, "DGL-3" indicates that a connection is made at socket "D" and ground lug #3 is used.

- ( ) Connect AB-2 to DGL-3 (S1).
- (✓) Connect PB-2 to EGL-1 (S1).
- (✓) Install 5/16" grommets at G1, G2, and G4.
- (✓) Install a 3/8" grommet at G3.
- ( ) Install the inter-stage transformer stamped 51-37 at T4. The black and the green wires are inserted in the opening nearest the octal socket (E). The red and blue wires are placed through the remaining opening; 6-32 hardware is used to secure. Install a #6 solder lug under the nut at the end nearest the chassis flange instead of the usual lockwasher.
- (✓) Connect the black wire of T4 to E7 (NS). Dress as shown in Pictorial 2.
- (✓) Connect the green wire of T4 to E5 (NS). Dress as shown.
- (✓) Install a 2-lug, one lug ground, terminal strip at "EE". Use a #6-32 x 1/4" RHMS with a lockwasher and nut.
- (✓) Connect a 2 1/4" length of #20 bare wire from E7 through E3 to PB-1 (solder all 3 connections).
- (✓) Connect one end of a 2 1/4" length of #20 bare wire to E5 (S2). Place a 3/4" length of sleeving on the wire and run the wire through E1. Place another 3/4" length of sleeving on the remainder of the wire and connect the end to PB-3 (S1). Solder E1 (S1).
- (✓) Before advancing further, temporarily select the balanced modulator chassis and the RF chassis. Hold them in place on the audio deck and, with a pencil, draw an outline of the chassis on the inside of the audio deck as shown in Figure 5. See Figure 13, Page 38 for parts identification and placement. From this point on, do not allow any of the wiring in these outlines, except the green and black wires from T4. Remove the two sub chassis and lay them aside. Proceed with deck wiring.
- (✓) Connect a 4 3/4" length of hookup wire from E6 (S1) to D2 (S1). Route as shown.

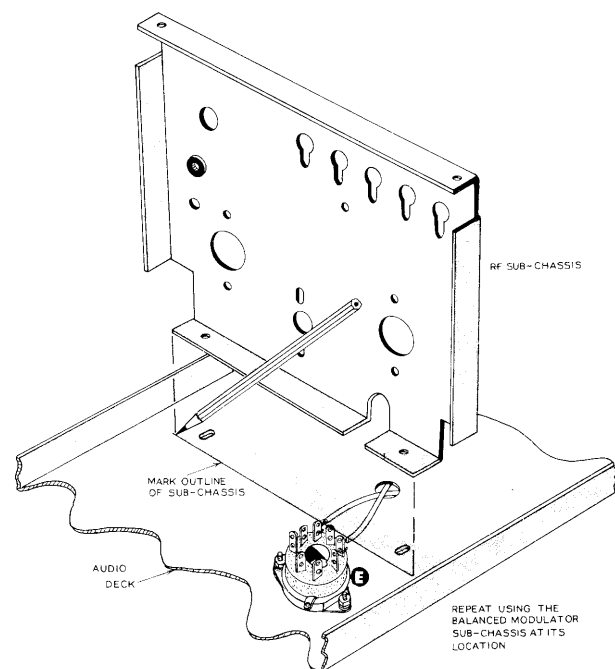

Figure 5



- (✓) Connect a 2 3/8" length of hookup wire from D7 (S1) to E2 (S1). Dress as shown.
- (✓) Connect a 15 KΩ (brown-green-orange) resistor from AA-1 (NS) to AA-2 (NS). Cut the leads to 3/8".
- (✓) Connect a 100 KΩ (brown-black-yellow) from A-1 (NS) to AA-1 (NS). Use sleeving on the end connecting to A-1. Cut the leads to 5/8" in length.
- (✓) Trimming the leads to 1/2", connect a 100 KΩ (brown-black-yellow) from A-7 (NS) to ground eyelet on AA (NS).
- (✓) Cut the leads of a 100 KΩ (brown-black-yellow) resistor to 1/2" and connect one lead to A6 (NS) and the other lead to AA-1 (NS).
- (✓) Cut both leads of a .01 mfd ceramic capacitor to 1/2". Connect from A6 (S2) to AA-3 (NS).
- (✓) Connect a #20 bare wire from the mounting foot eyelet on terminal strip AA (NS) through pin A4 to socket "A" center shield then to pin A5. Now solder A4 and A5.
- (✓) Cut one lead of a 1 megohm (brown-black-green) resistor to 3/8", connect to A2 (NS).
- (✓) Insert remaining lead through the mounting foot eyelet of AA (NS). Cut off excess wire.
- (✓) Trim the leads of a 1 KΩ (brown-black-red) resistor to 3/8". Connect from A3 (S1) to AA mounting foot eyelet (S4).
- (✓) As shown in Pictorial 2, connect one lead of a 3.3 KΩ (orange-orange-red) resistor to A8 (S1). Connect the other lead to the "A" socket center shield (NS), dressing the lead between lugs 1 and 9.

See the Detail on Pictorial 2 for the next two steps.

- (✓) Trim the leads of a 100 mmf disc ceramic capacitor to 3/8". Connect it from A2 (NS) to the "A" socket center shield (S3).
- (✓) Trim the leads of a .01 mfd ceramic capacitor to 5/8". Use 3/8" of sleeving on each lead and connect from A1 (S2) to A7 (S2).
- (✓) Cut a piece of hookup wire 1 3/4" long. Connect one end to A9 (NS). Connect the other end to B3 (NS).
- (✓) Cut a piece of hookup wire 4 3/4" long. Connect one end to A9 (S2) and connect the other end to D9 (NS).
- (✓) Cut the leads of a 100 KΩ (brown-black-yellow) resistor to 1/2". Connect one end to B1 (NS). Connect the other end to ground lug which is secured by the hardware at socket B (NS).
- (✓) Cut one lead of a .01 mfd ceramic capacitor to 1", slip a 3/4" length of sleeving over the lead and connect it to B1 (S2).
- (✓) Cut the other lead to 1/2" and connect it to C1 (NS).
- (✓) Connect a 100 KΩ (brown-black-yellow) resistor across socket B, from B2 (NS) to B7 (NS). Pull the leads through so that the resistor lays on the socket.
- (✓) Cut one lead of a 5.6 megohm (green-blue-green) resistor to 1/2", connect it to B7 (NS).
- (✓) Cut the other lead to 7/8" and connect it to the ground lug at socket B (NS).



- (✓) Select a .01 mfd disc ceramic capacitor. Cut one lead to 1", the other to 1 1/4". Cut a piece of sleeving to 1" and place it over the longer lead. Connect the longer lead to B2 (S2). Do not connect the 1" lead yet.
- (✓) Connect a #20 bare wire from B6 through B4 to the socket "B" ground lug. Cut off excess wire and solder all three connections. There will be three leads on the ground lug.
- (✓) Cut one lead of a .1 mfd 200 volt tubular capacitor to 1". Place a 3/4" length of sleeving on this lead and connect it to B7 (S3). Connect the other to the ground lug secured under the socket "C" mounting hardware (NS).
- (✓) Cut both leads of a 1 K $\Omega$  (brown-black-red) resistor to 1/2". Connect one lead to C3 (S1) and the other lead to terminal strip lug BB-2 (NS).
- (✓) Cut a #20 bare wire to 1 1/2". Dress it through BB2 to C4 to socket "C" center shield, then back to pin C5. Solder C4, C5 and the center shield.
- (✓) Cut one lead of a 1 K $\Omega$  (brown-black-red) resistor to 1/2" and the other to 7/8". Connect the 1/2" lead to C8 (S1). Connect the 7/8" lead to BB2 (NS).
- (✓) Cut one lead of a 100 K $\Omega$  (brown-black-yellow) resistor to 1/2" and the other lead to 1". Connect the 1/2" lead to C1 (S2). Place a 5/8" length of sleeving on the 1" wire and connect it to BB1 (NS).
- (✓) Cut one lead of a 100 K $\Omega$  (brown-black-yellow) resistor to 1/2" and connect it to pin C6 (NS). Cut the other lead to 5/8" and connect it to BB1 (NS).
- (✓) One end of a .01 mfd capacitor has been connected to B2. Locate this capacitor and now connect the loose lead to C6 (S2). Use a 3/4" length of sleeving on the lead.
- (✓) Cut both leads of a 2.2 megohm (red-red-green) resistor to 1/2". Connect one lead to C7 (S1). Connect the other lead to BB-3 (NS).
- (✓) Cut the leads of a 1.5 K $\Omega$  (brown-green-red) 2 watt resistor to 7/8". Connect one end to F8 (NS). Connect the other lead to FF2 (NS).
- (✓) Connect a 220 $\Omega$  (red-red-brown) 2 watt resistor to F8 (NS) and connect the other end to FF3 (NS).
- (✓) As shown in Pictorial 2, cut one lead of a 100 K $\Omega$  (brown-black-yellow) 2 watt resistor to 3/4" and connect it to FF1 (NS). Use a 1 1/4" length of sleeving on the other lead and connect it to F8 (S3).
- (✓) Locate the blue lead from transformer T4, as indicated in Pictorial 2, trim to 1 5/8" and connect it to F1 (NS).
- (✓) Cut the red lead of T4 to 1 3/4". Strip the end and connect this lead to FF1 (NS).
- (✓) Cut a 1 1/2" length of #20 bare wire. Pass it through FF2, through F4, through socket "F" center shield, then bend it back to F5. Solder F4, F5 and center shield.
- (✓) Cut the leads of a 680  $\Omega$  (blue-gray-brown) resistor to 1/2". Connect one lead to F3 (NS). Connect the other lead to FF2 (NS).
- (✓) Cut the positive lead of the 2 mfd 50 volt electrolytic capacitor to 1 1/2". Place a 1 1/8" length of sleeving on this lead and connect it to F3 (S2). Connect the negative lead to the solder lug at the T4 mounting screw (NS). Position the capacitor as shown.
- (✓) Cut the leads of a 2.2 megohm (red-red-green) resistor to 5/8". Connect one lead to F7 (NS) and connect the other lead to FF2 (S4).
- (✓) Cut the leads of a .005 mfd disc ceramic capacitor to 5/8". Place a 3/8" length of sleeving on each lead. Connect one lead to F1 (S2) and the other lead to FF1 (NS). Position the capacitor over the socket.

- (✓) Cut one lead of a .1 mfd, 200 volt capacitor to 1 1/4" in length. Place a 1" length of sleeving on the lead and connect it to F7 (NS).
- (✓) Insert the remaining lead through the solder lug which is secured by the mounting hardware of T4. Pull the lead through this lug and dress the capacitor close to the chassis (S2). Trim off excess wire.

Refer to Pictorial 3 for the following steps:

- (✓) Install the relay on top of the chassis through G4 and mount a 2-lug terminal strip, one lug ground, and secure with a #6 nut and lockwasher underneath the chassis.

- (✓) Strip the ends of a 6" length of hookup wire. Connect one end to F6 (S1), dress the wire through grommet G2 and connect it to RY1 (S1). See Figure 6 for relay lug numbering.

- (✓) Strip the ends of a 5 1/2" length of hookup wire. Connect one end to FF1 (NS), dress the wire through grommet G2 and connect to RY2 (NS).

- (✓) Strip the ends of a 2" length of hookup wire. Connect one end to RY2 (S2) and the other end to RY6 (S1).

- (✓) Select one of the two modulation transformers stamped 51-38. Before installing it as T1, cut the red lead to 3", cut the blue lead to 4 1/4". Strip the ends of these wires 3/16" and temporarily mount the transformer with the red and blue leads inserted in the opening which is nearest socket "A". The black and green wires are placed through the other opening. Use #6-32 x 1/4" screws and #6 nuts.

- (✓) Connect the 3" red lead to AA2 (NS). Dress as shown in Pictorial 3.

- (✓) Referring to Pictorial 3, dress and connect the blue lead to D1 (S1).

- (✓) Select the second modulation transformer stamped 51-38. Cut the red lead to 6" and the blue lead to 2 1/4". Remove 3/16" of insulation from these leads and insert the leads in the opening nearest socket "D". Place the green and black leads through remaining opening at T3 and temporarily secure the transformer at one of the mounting holes with #6-32 x 1/4" screws and #6 nuts.

- (✓) Connect the blue lead from T3 to D6 (S1).

- (✓) Connect the red lead to AA2 (NS). Dress both leads as shown in Pictorial 3.

- (✓) Cut a 1 1/4" length of #20 bare wire. Connect one end to D5, through socket "D" center shield, through D4 to #2 ground lug at socket "D". Trim excess wire. Solder ground lug, D4, D5 and center shield.

- (✓) Cut the leads of a 220Ω (red-red-brown) resistor to 1". Place a 3/4" length of sleeving over each lead. Connect one lead to D3 (S1). Connect the other lead to AB3 (S1).

- (✓) Cut the leads of a 220Ω (red-red-brown) resistor to 3/8". Connect one end to D8 (S1) and connect the other end to AB1 (S1).

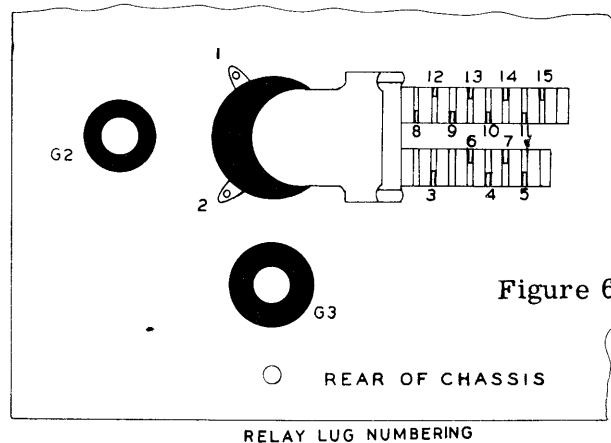

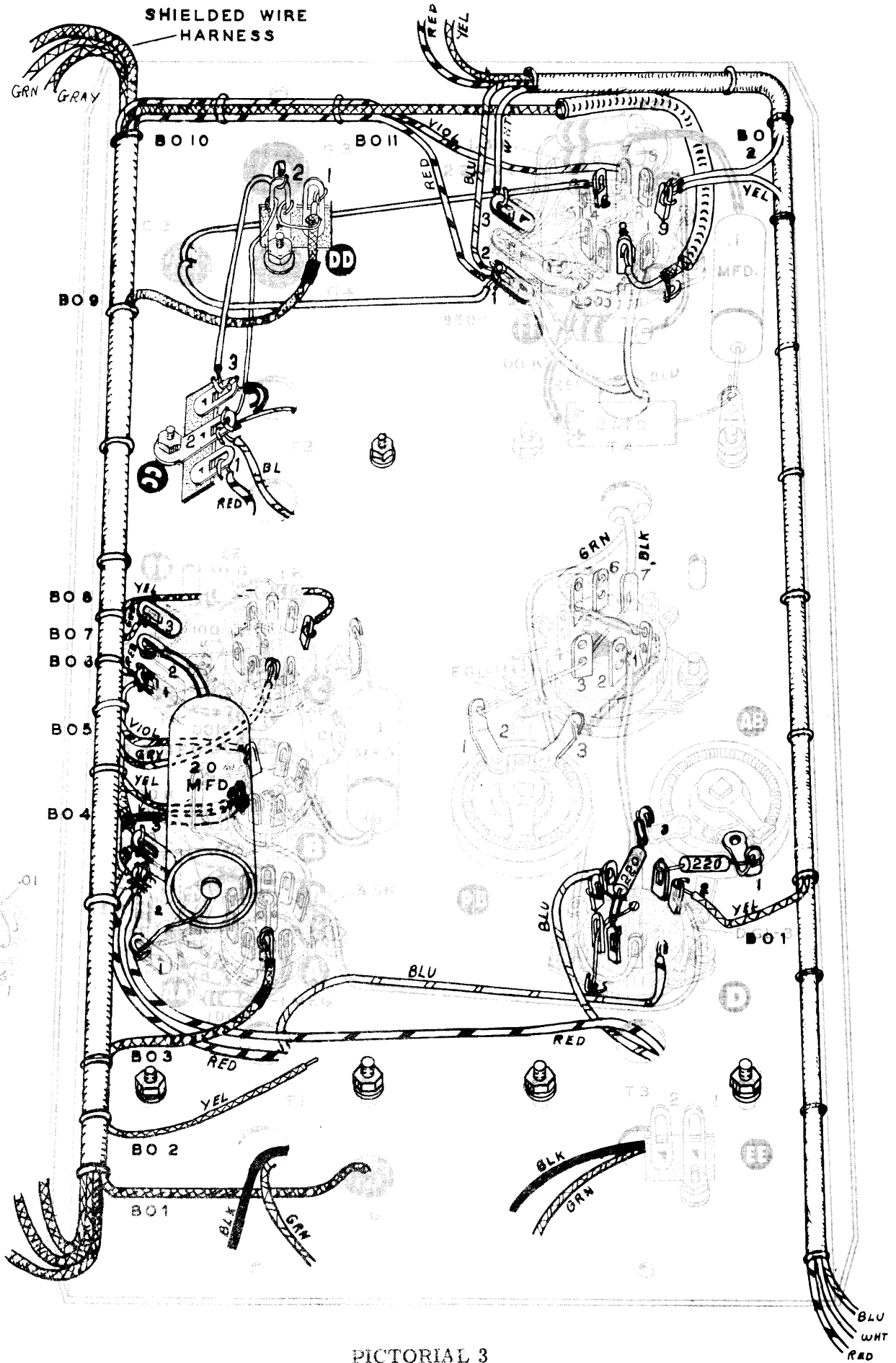

PICTORIAL 3

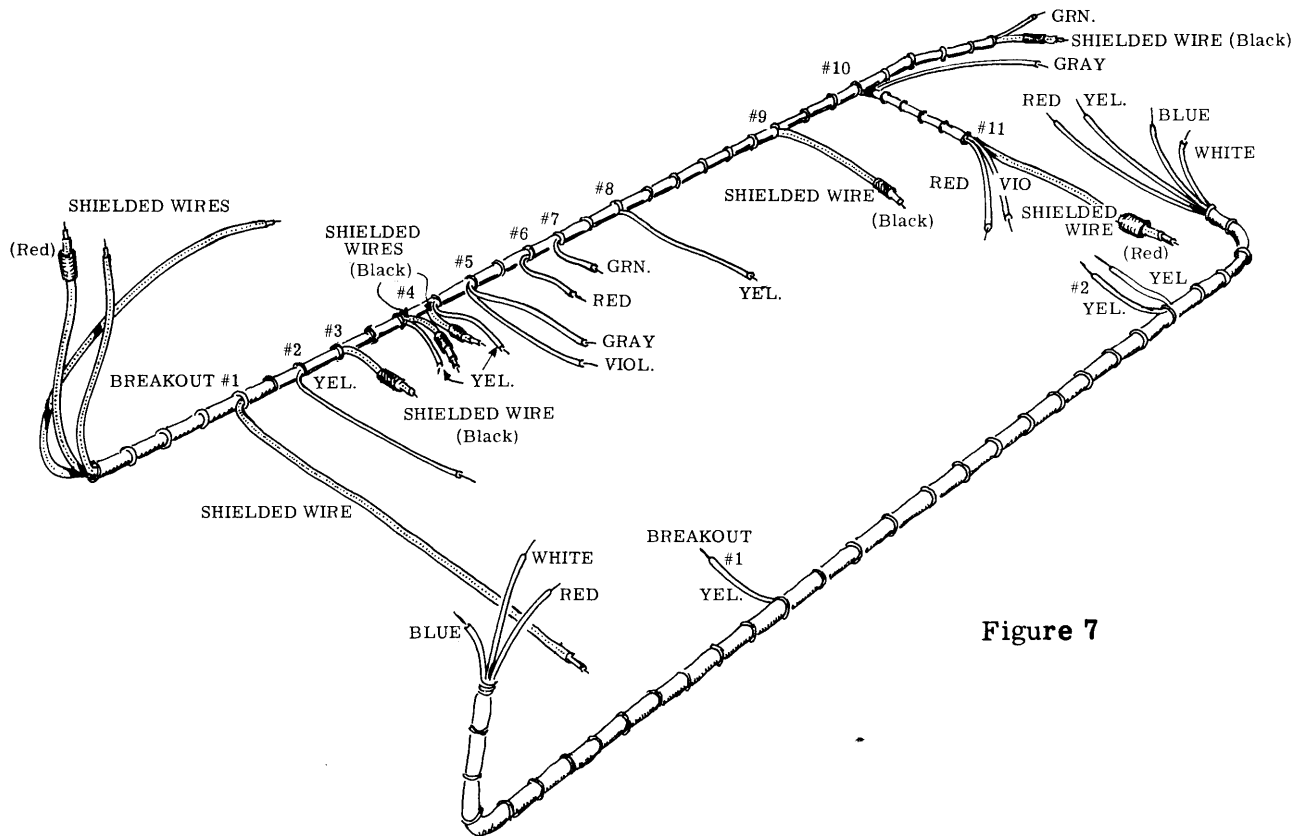

Figure 7

( ) Select and install the wiring harness which contains shielded wire, dressing to conform with Pictorial 3. Refer to Figure 7 for harness layout.

Connect wires breaking out of the harness as follows:

- (✓) Number 1 breakout (shielded): place through grommet G1 to be connected later.
- (✓) Number 2 breakout (yellow): to be connected later.
- (✓) Number 3 breakout (shielded); connect to A2 (S3).
- (✓) Number 4 breakout (shielded): connect both short shielded wires to AA3 (S3).
- (✓) Number 4 breakout (yellow): connect both yellow wires to B3 (S3).
- (✓) Number 5 breakout (violet): connect to B5 (S1).
- (✓) Number 5 breakout (gray): connect to C2 (S1).
- (✓) Number 6 breakout (red): connect to BB1 (NS).
- (✓) Strip the ends of a 3" length of hookup wire to 3/16". Connect one end to AA2 (S4). Connect the other end to BB1 (S4).
- (✓) Number 7 breakout (green): connect to BB3 (S2).
- (✓) Number 8 breakout (yellow): connect to C9 (NS).
- (✓) Number 9 breakout (shielded): connect the center conductor to DD1 (NS), and connect the shield to DD2 (NS).

- (✓) Number 10 breakout (3 wires): bend them out of the way, to be connected later.
- (✓) Number 11 breakout (red): connect to FF1 (NS).
- (✓) Number 11 breakout (violet): connect to F7 (S3).
- (✓) Install a 2 1/2" length of clear plastic sleeving on the red marked shielded wire at the end of the harness and push it back to the last (11th) breakout point.
- (✓) Connect the shield of this wire to ground lug #1 on socket "F" (S1). Use a short length of bare wire to make the connection, if necessary.
- (✓) Connect the center conductor to F2 (S1).
- (✓) Pull the clear plastic sleeving back down and close to the end of the shield.
- (✓) Install the second wiring harness, shown in Figure 7, in place on the deck. Locate breakouts as shown on Pictorial 3 and connect wires as follows:
- (✓) Number 1 breakout (yellow): connect the yellow wire to D9 (S2).
- (✓) Number 2 breakout (2 yellow): both connect to F9 (S2).
- (✓) At the harness end nearest breakout #2, connect the white lead to FF3 (S2).
- (✓) Connect the blue lead to FF1 (S6). The red and yellow leads are connected later.
- (✓) Cut the leads of a 20 mfd 350 volt electrolytic capacitor to 1 1/2". Place a 1 1/4" length of sleeving on each lead, connect the positive (+) lead to AA1 (S4).
- (✓) Dress the capacitor across socket "A" and "B", connect the negative (-) lead to BB2 (S4).
- (✓) Install the anti-trip input transformer, 51-3. Dress the leads as shown, through their respective openings at T2. Install a 3-lug, center ground, terminal strip at "CC" as shown. Secure the transformer with 1/4" 6-32 RHMS, #6 lockwashers and 6-32 nuts. The 3-lug terminal strip should be installed with the mounting foot between the lockwasher and nut.
- (✓) Connect the red lead from T2 to CC1 (NS).
- (✓) Connect the blue lead from T2 to CC2 (NS).
- (✓) Place sleeving on one of the enameled leads from T2 and connect it to CC3 (NS).
- (✓) Connect the other enameled lead to CC2 (NS). Sleeving is not required.
- (✓) Dress a 3 3/8" length of #20 bare wire, from DD2 (NS) to CC2 (S3), under existing wires and close to chassis.
- (✓) Strip the ends of a 5 3/4" length of hookup wire and connect from CC3 (NS) through grommet G3 to RY8 (S1).
- (✓) Strip the ends of a 3 3/4" length of hookup wire. Connect it through G3 from DD2 (S3) to RY11 (NS).

This completes preliminary wiring of the audio deck. Recheck your work and then set the deck aside temporarily.

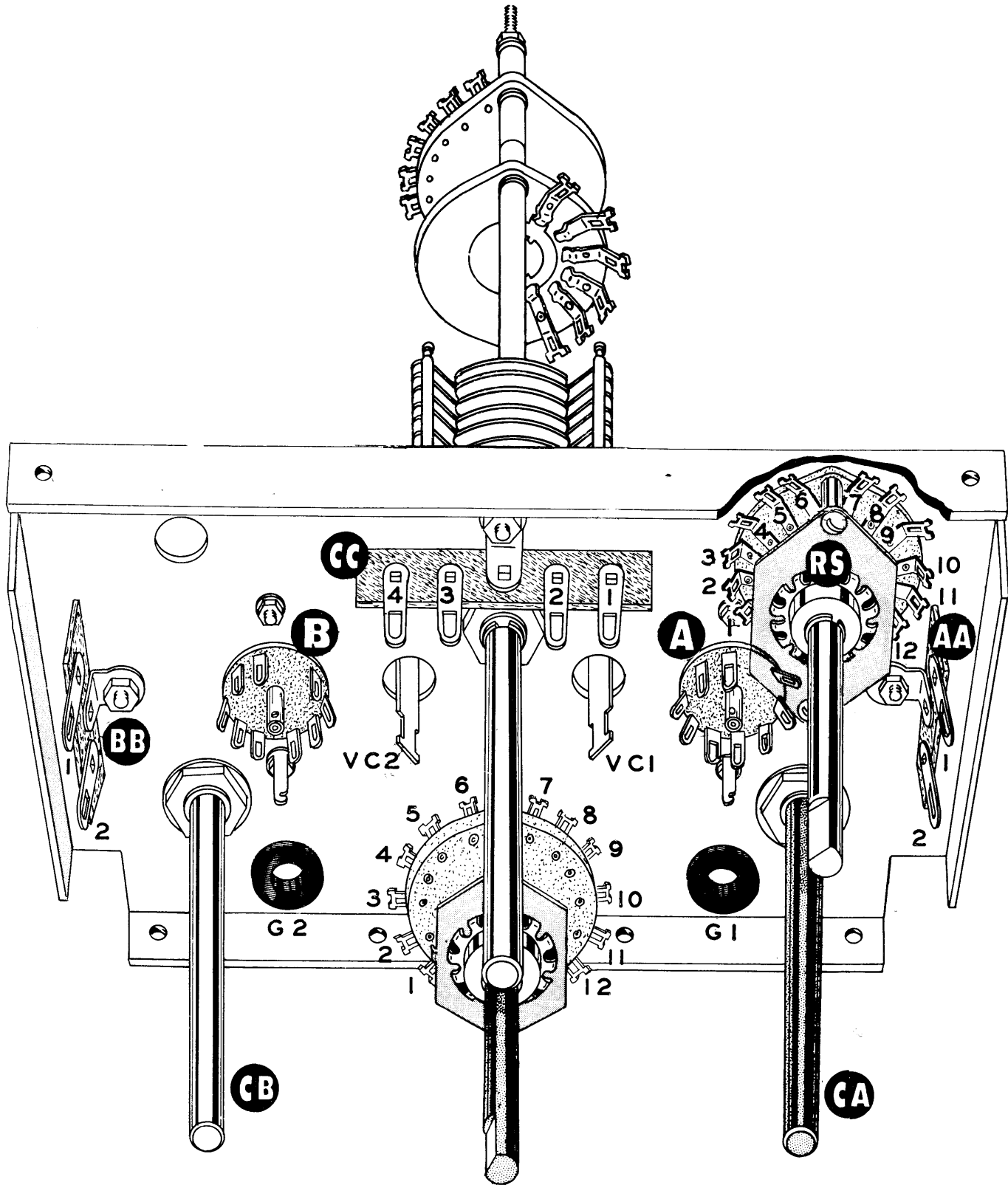

PICTORIAL 4

## ASSEMBLY AND WIRING OF THE BALANCED MODULATOR SUB-CHASSIS

Refer to Pictorials 4 and 5 for parts mounting and wiring.

- (✓) Mount 9 pin shielded ceramic sockets at locations "A" and "B". Position vacant pin space as shown in the Pictorial. Place a small #6 solder lug under the mounting hardware nearest pins 4 and 5 of each socket. Secure with #3 lockwasher and 3-48 nuts.

**CAUTION:** Carefully inspect the bandswitch 63-158 and note the position of the key marks on the wafer rotors. Both should be on the same side of the switch shaft. If not, during disassembly, remove the front deck and replace with the key mark in line with the rear deck key mark. Check the detailed bandswitch drawing in Figure 8 which shows the switch in full CCW position. Note the proper relation between the shaft flat and the wafer key marks and contact arrangement.

- (✓) Disassemble band switch 63-158 and reassemble to the sub-chassis as shown in Figure 8. Insert the coil and two wafer assembly on the band switch as shown placing the wafer with lugs at BS3-2 and BS3-5 toward the rear. During reassembly, use care to observe proper orientation of the wafers and index plate per the detailed drawing. Make sure a fiber washer is placed between the ceramic wafer and the metal spacer.

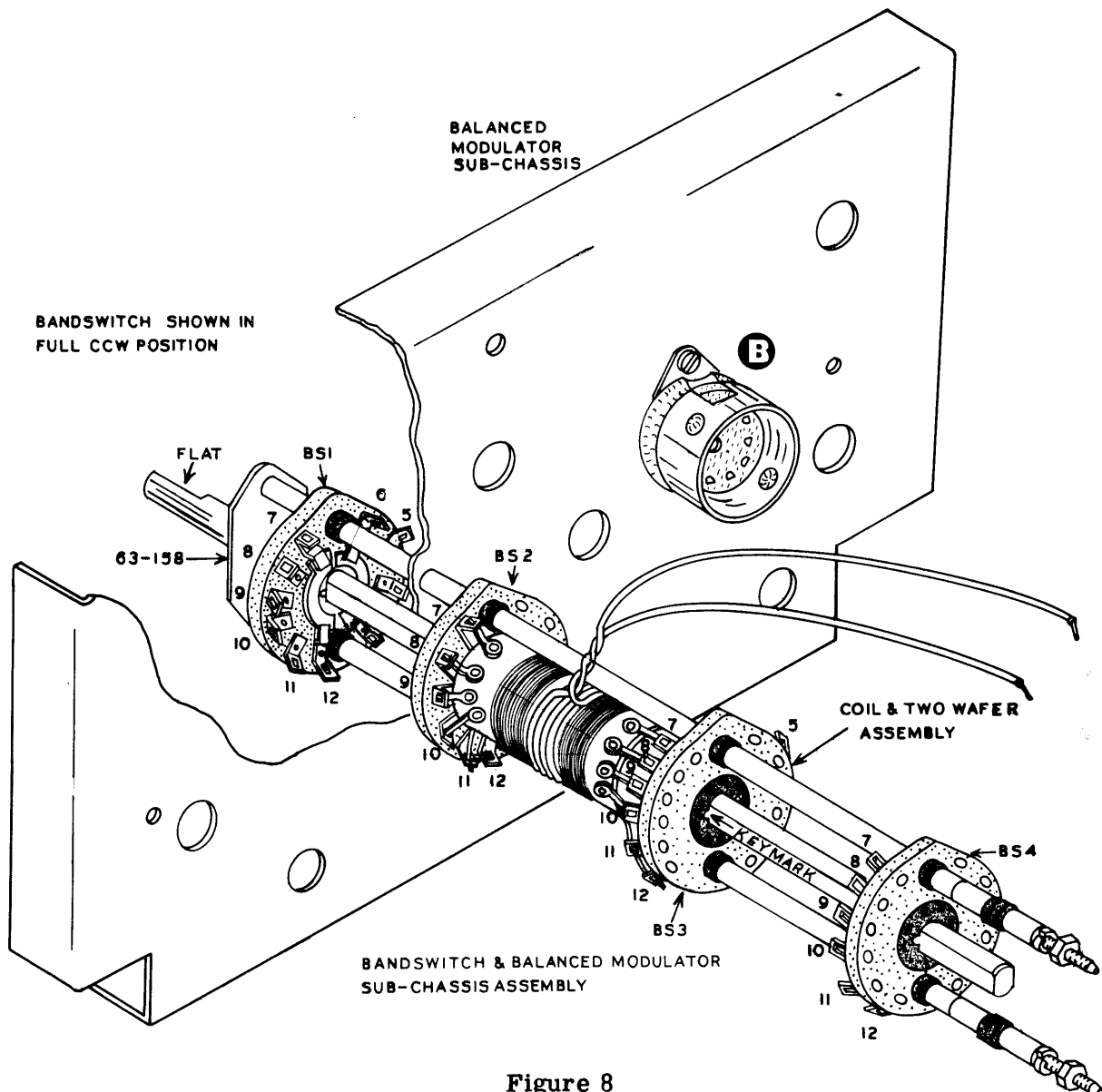

Figure 8

- (✓) Install 3/8" grommets at G1 and G2.
- (✓) Install the 1 K $\Omega$  carrier balance controls at CA and CB. Place control ground lug on control as shown, form over the #2 lug and cut off excess lug. Solder lug 2 of control to ground lug. Refer to Figure 10, page 29.
- (✓) Install the variable tuning capacitor 26-46, at VC with a 3/8" lockwasher on the bushing, then insert the shaft at VC. Align the lugs on the front of the variable capacitor so they will not short to the sides of holes VC1 and VC2. Secure the capacitor with a 3/8" nut and flat washer.
- (✓) Mount a 4 lug, no ground terminal strip at CC and orient as shown in Pictorial 4.
- (✓) Mount 2 lug, no ground, terminal strips at AA and at BB.
- (✓) Install the side band reversing switch at RS as shown in Pictorial 4. The switch mounts on its assembly screws with the extra nuts and lockwashers supplied on the switch. Note the position of the flat with switch full CCW, as shown.
- (✓) Connect a 1" length of #20 bare wire from the stator lug at VC-2 (NS) to B1 (S1).
- (✓) Connect a similar wire from VC1 (NS) to A6 (S1).
- (✓) Cut two 3 1/4" lengths of #20 bare wire and two 2 1/2" lengths of sleeving. Place the sleeving on the wires.
- (✓) Connect one wire between VC1 (S2) and B6 (S1).
- (✓) Connect the other wire from VC2 (S2) to A1 (S1).
- (✓) Bend the solder lug located next to A4 and A5 so that the lug touches both pins.
- (✓) Connect a 1/2" length of #20 bare wire from the center shield of socket A through the ground lug at A4 and A5 (NS).
- (✓) Bend the solder lug located next to B4 and B5 so that the lug touches both pins.
- (✓) Connect a 1/2" length of #20 bare wire from the center shield of socket B through the ground lug at B4 and B5 (NS).
- (✓) Cut the leads of a .001 mfd disc ceramic capacitor to 3/8". Connect one lead to A8 (NS); connect the other lead to socket A center shield (NS).
- (✓) Cut the leads of a .001 mfd disc ceramic capacitor to 3/8". Connect one lead to A3 (NS); connect the other lead to socket A center shield (S3).
- (✓) Repeat these last 2 steps at socket B, using two more .001 capacitors.
- (✓) Remove 3/16" of insulation from the ends of a 3 3/4" length of hookup wire. Connect one end to A9 (S1). Connect the other end to B9 (NS). Dress close to chassis.
- (✓) Strip the ends of a 1 1/4" length of hookup wire. Connect one end to RS1 (S1), and the other end to AA1 (NS).
- (✓) Connect a 3/4" length of #20 bare wire between RS2 (S1) and RS3 (NS).
- (✓) Connect one end of a 2 1/2" length of hookup wire to RS3 (S2). Now, dress this lead under the switch to RS8 (NS) as shown in Pictorial 5 on page 26.
- (✓) Connect a 1 3/4" length of #20 bare wire with sleeving from RS4 (NS) through RS6 (NS) to RS7 (NS). Dress the lead around the inside of the mounting post as shown in Pictorial 5. Now, solder RS4 (S1) and RS6 (S1).



- (✓) Strip the ends of a 4" length of hookup wire. Connect one end to RS5 (S1). Dress the lead under the switch and close to the chassis and connect to AA2 (NS).
- (✓) Connect a 9" length of hookup wire from RS9 (S1) to BB2 (NS).
- (✓) Connect an 8 1/2" length of hookup wire from RS10 (S1) to BB1 (NS). Dress as shown in Pictorial 5.
- (✓) Connect a 3/4" length of #20 bare wire from RS11 (NS) to RS12 (S1).
- (✓) Cut the leads of a 50Ω precision resistor to 3/4". Position as shown and connect one end to CC1 (NS). Feed the other lead through the eyelet of the CC terminal strip mounting foot (S1). Cut off excess wire.
- (✓) Cut the leads of a 15 KΩ (brown-green-orange) resistor to 1/2". Connect one lead to B2 (NS). Connect the other lead to the ground lug on socket B near B4 and B5 (NS).
- (✓) Cut the leads of another 15 KΩ (brown-green-orange) resistor to 1/2". Connect one lead to B7 (NS). Connect the other lead to socket B ground lug (NS).
- (✓) Repeat the last 2 steps with 15 KΩ resistors at socket A. Now solder A4, A5 and both 15 KΩ resistor leads and the lead from the center post to the socket A ground lug.

NOTE: In the following steps "BS" indicates the Band Switch, 63-158. A notation of "BS2", for example, will indicate the second wafer from the front and a notation of "BS2-3" will indicate that the wire or component is connected to wafer #2, terminal #3.

- (✓) Strip the ends of a 2 1/8" length of hookup wire. Connect one end to BS1-6 (NS). Connect the other end to CC4 (NS).
- (✓) Strip the ends of a 3" length of hookup wire. Connect one end to CC1 (NS). Leave the other end free to be connected later.
- (✓) Cut one lead of a 100 mmf (brown-black-brown) mica capacitor to 3/4". Pass this lead through CC1 (NS) to CC2 (NS). Now dress the capacitor as shown and solder CC1 (S3). Do not solder CC2.
- (✓) Cut a 1 1/8" length of sleeving. Place it on the remaining uncut lead of the above capacitor and connect it to A2 (NS).
- (✓) Cut one end of a 100 mmf (brown-black-brown) mica capacitor to 1/2" and connect it to CC2 (S2). Position as shown in Pictorial 5.
- (✓) Cut the other lead of the above 100 mmf mica capacitor to 1 1/8". Use sleeving and connect to A7 (NS).
- (✓) Select another 100 mmf (brown-black-brown) mica capacitor. Cut one lead to 3/4" and pass this lead through CC4 (NS) to CC3 (NS). Position as shown and solder CC4 (S2).
- (✓) Cut a 1 1/8" length of sleeving. Place it on the other uncut lead of the above 100 mmf capacitor and connect to B7 (NS).
- (✓) Select another 100 mmf (brown-black-brown) mica capacitor. Cut one lead to 1/2" and connect this lead to CC3 (S2). Position as shown.
- (✓) Cut the remaining lead of the above 100 mmf capacitor to 1". Use a 3/4" length of sleeving and connect to B2 (NS).

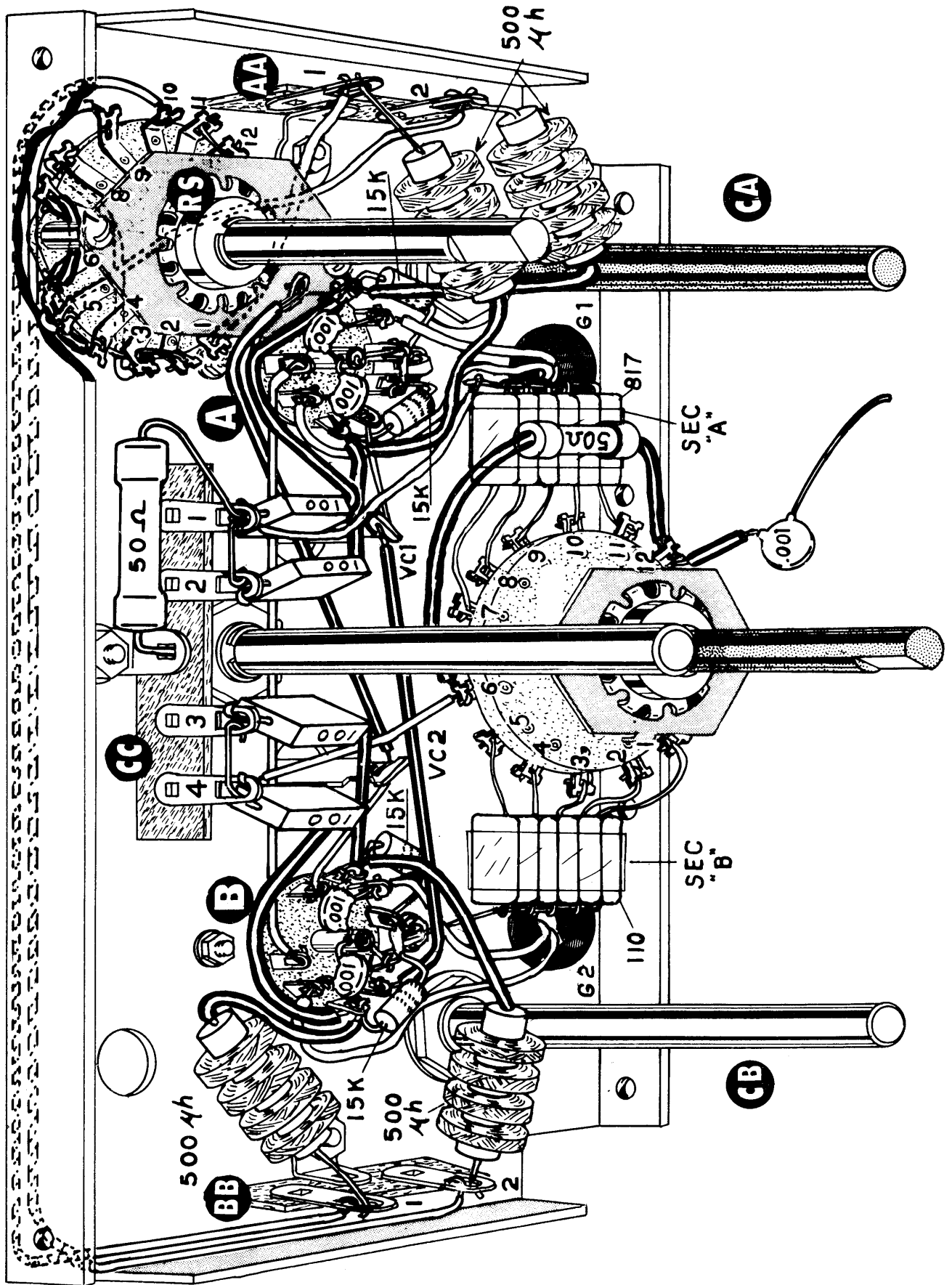

PICTORIAL 5

- (✓) Strip the ends of a 2 3/4" length of hookup wire and connect one end to A3 (S2). Dress the other end as shown through grommet G1 to CA1 (S1).
- ( ) Strip the ends of a 3 1/4" length of hookup wire. Connect one end to A8 (S2). Connect the other end through grommet G1 to CA3 (S1).
- ( ) Strip the ends of a 2 3/4" length of hookup wire. Connect one end to B3 (S2). Dress the wire through G2 and connect it to CB1 (S1).
- (✓) Strip the ends of a 3 1/2" length of hookup wire. Connect one end to B8 (S2). Dress the lead through grommet G2 and connect it to CB3 (S1).

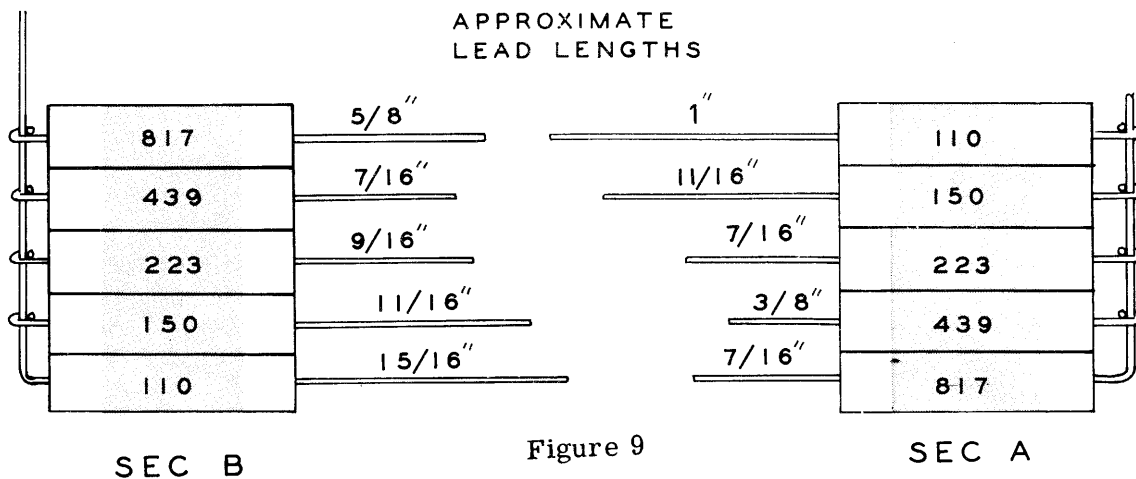

- (✓) Select the ten silver mica precision capacitors. Stack them into two stacks in the same sequence as shown in Figure 9. To hold them in place, a binding of scotch tape is very helpful in this step.
- ( ) Recheck each stack of five capacitors to make sure that each capacitor is in its place. Bend the lead of the 817 mmf capacitor of one stack (section "A") as shown in Figure 9.
- (✓) Very carefully bend each capacitor lead around the lead from the 817 mmf capacitor. Cut off excess wire from each lead. Solder all except the 110 mmf capacitor lead.
- ( ) Bend the lead of each capacitor to conform with the switch terminals as shown in Pictorial 5. Cut the individual leads to fit. Take extreme care in fitting them as each lead is of a different length.

Approximate lengths of these leads for Section "A" are as follows:

- 1st capacitor (817 mmf) - 7/16"
- 2nd capacitor (439 mmf) - 3/8"
- 3rd capacitor (223 mmf) - 7/16"
- 4th capacitor (150 mmf) - 11/16"
- 5th capacitor (110 mmf) - 1"

- ( ) Lay the stack in place at location "A" as indicated in Pictorial 5. Dress close to the chassis. Insert each capacitor lead in its respective lug on the switch wafer and connect as follows:
- (✓) Connect the 817 mmf lead to BS1-11 (S1).
- ( ) Connect the 439 mmf lead to BS1-10 (S1).
- (✓) Connect the 223 mmf lead to BS1-9 (S1).

- (✓) Connect the 150 mmf lead to BS1-8 (S1).
- (✓) Connect the 110 mmf lead to BS1-7 (S1).
- (✓) Connect the loose end of the 3" length of hookup wire, which was connected earlier to CC1, to the unsoldered end of the section "A" 110 mmf silver mica capacitor (S3). Trim excess wire from the bank of capacitors.
- (✓) Section "B" is treated in a similar manner except, observe that the 110 mmf silver mica capacitor lead is bent along the end of each capacitor, and the sequence of the bank is reversed. Each capacitor lead is trimmed and wrapped once around the lead from the 110 mmf capacitor. Solder all four connections. Do not trim the excess of the 110 mmf lead capacitor. See Figure 9 on page 27. Trim leads per Pictorial 5 and the approximate lengths given below:

1st capacitor (110 mmf) - 15/16"  
 2nd capacitor (150 mmf) - 11/16"  
 3rd capacitor (223 mmf) - 9/16"  
 4th capacitor (439 mmf) - 7/16"  
 5th capacitor (817 mmf) - 5/8"

- (✓) Lay the capacitor configuration in place near the band switch at location as shown in Pictorial 5.
- (✓) Dress the capacitor leads to fit in their respective lugs on the band switch and solder each in place as follows:
  - (✓) Connect the 110 mmf lead to BS1-1 (S1).
  - (✓) Connect the 150 mmf lead to BS1-2 (S1).
  - (✓) Connect the 223 mmf lead to BS1-3 (S1).
  - (✓) Connect the 439 mmf lead to BS1-4 (S1).
  - (✓) Connect the 817 mmf lead to BS1-5 (S1).
- (✓) Connect the common lead, to which all of the capacitors are soldered, to the ground lug at socket "B". Now solder all connections at socket "B" ground lug. (Make sure all wires are soldered.)
- (✓) Trim both leads of a 50Ω precision resistor to 1 1/4". Cut two 1" lengths of sleeving and place them on the resistor leads.
- (✓) Connect one 50Ω precision resistor lead to BS1-6 (S2). Connect the other lead to BS1-12 (NS). Dress as shown.
- (✓) Cut one lead of a .001 mfd disc ceramic capacitor to 5/8". Install a 3/8" length of sleeving on this lead and connect to BS1-12 (S2). The other lead is connected later.
- (✓) Cut one lead of a 500 μh choke to 7/8". Connect it to B2 (S3). Use sleeving. Cut the other lead to 5/8", and connect it to BB2 (S2).
- (✓) Cut one lead of a 500 μh choke to 1". Use a 5/8" length of sleeving on the lead and connect it to B7 (S3). Cut the other lead to 3/8" and connect it to BB1 (NS).
- (✓) Cut a lead of a 500 μh choke to 1" and use a 5/8" length of sleeving. Connect this lead to A2 (S3). Connect the other end to AA2 (S2).

- (✓) Cut a lead of a 500  $\mu$ h choke to 7/8" and use a 5/8" length of sleeving. Connect this lead to A7 (S3). Cut the other lead to 1/4" and connect it to AA1 (S2).
- (✓) Cut a 3 1/2" length of #16 bare wire. Connect the wire as in Figure 10 between BS2-11 (S) and VC-2 (S1).
- (✓) Cut a 2 3/4" length of #16 bare wire. Connect as shown in Figure 10 from BS3-11 (S2) to VC1 (Stator Bar) (S1).

This completes preliminary wiring of the balance modulator sub-chassis. Recheck your work and set the sub-chassis aside temporarily.

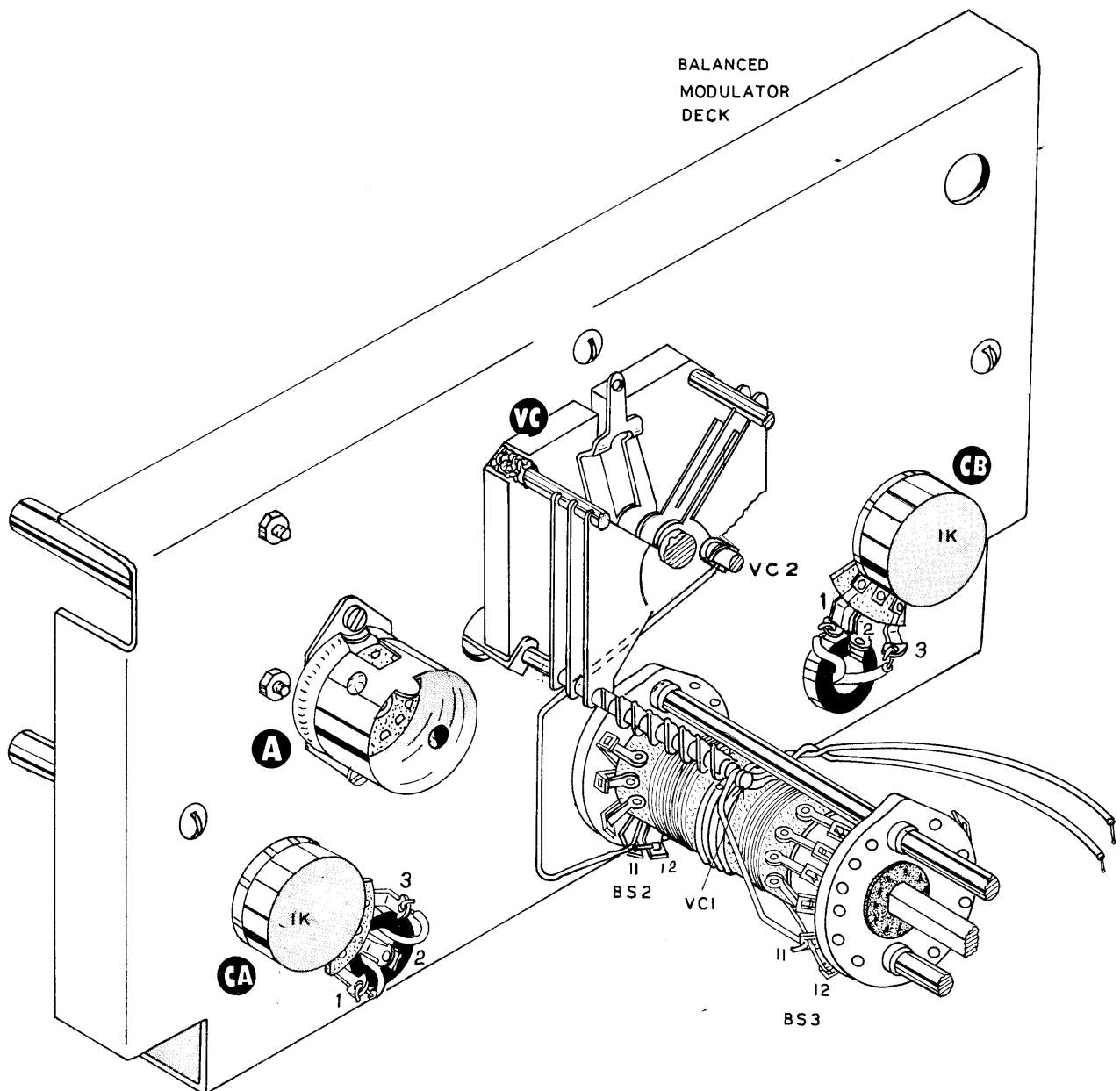
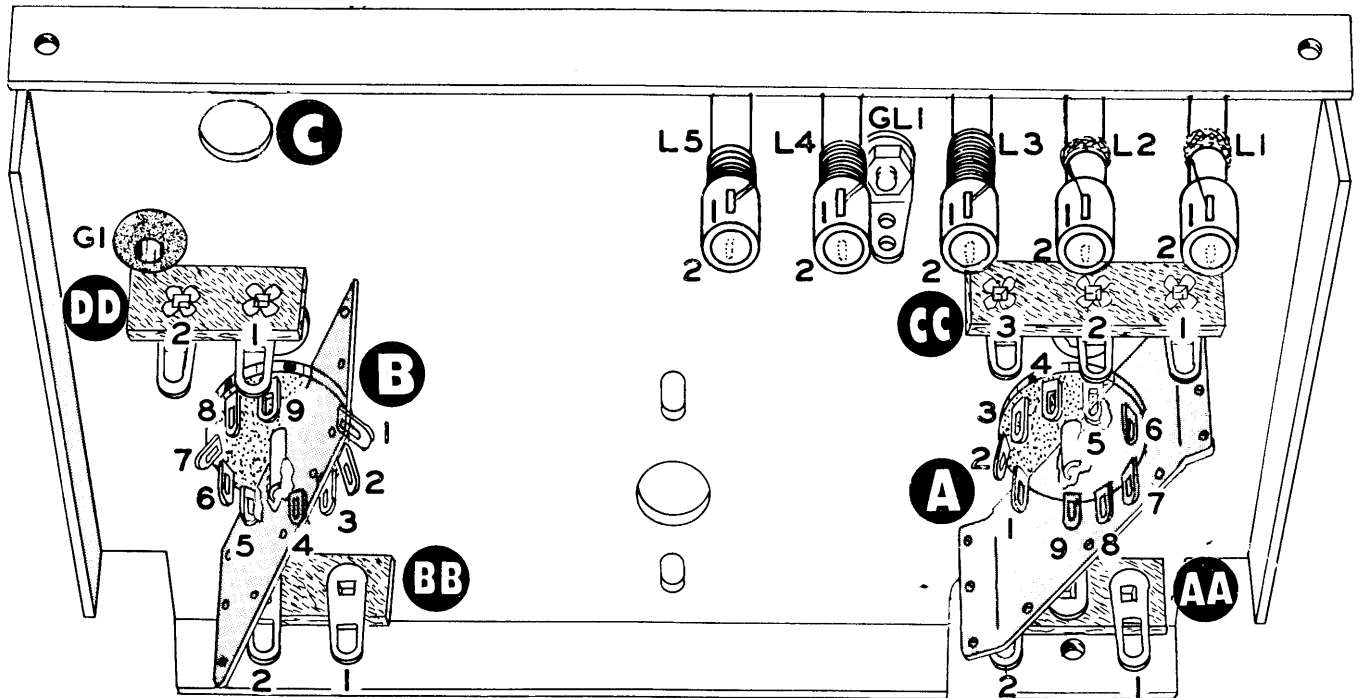

Figure 10



PICTORIAL 6

### ASSEMBLY AND WIRING OF THE RF SUB-ASSEMBLY

Refer to Pictorials 6 and 7 for component mounting and wiring.

- (✓) Mount a 9 pin shielded miniature ceramic socket at "A" and position as shown in Pictorial 6. Install a 2-lug no ground terminal strip at the end of the socket nearest pin 9. Mount a 3-lug, center ground terminal strip at the other end. Use 3-48 BHMS screws, #3 lock-washers and 3-48 nuts.
- (✓) Repeat the above step at "B" but orient the socket opposite to "A" and use a 2-lug, one ground strip at each end of the socket as shown in Pictorial 6. Secure with 3-48 hardware.
- (✓) Install a 5/16" grommet at G1.
- (✓) Mount a #6 ground lug at GL1. Use 6-32 x 1/4" RHMS and a #6-32 nut.
- (✓) Select the 2 tinned pin shields and install them on sockets "A" and "B" as shown in Pictorial 6. Solder them in place at the tube socket center shield, allowing the shield to touch pin 5 of each socket, which will be soldered later. Bend the shield at "A" as shown to clear the terminal strips.

NOTE: The two pin shields are used as grounding strips for several of the components associated with each socket. Solder holes are provided in several locations on the shield.

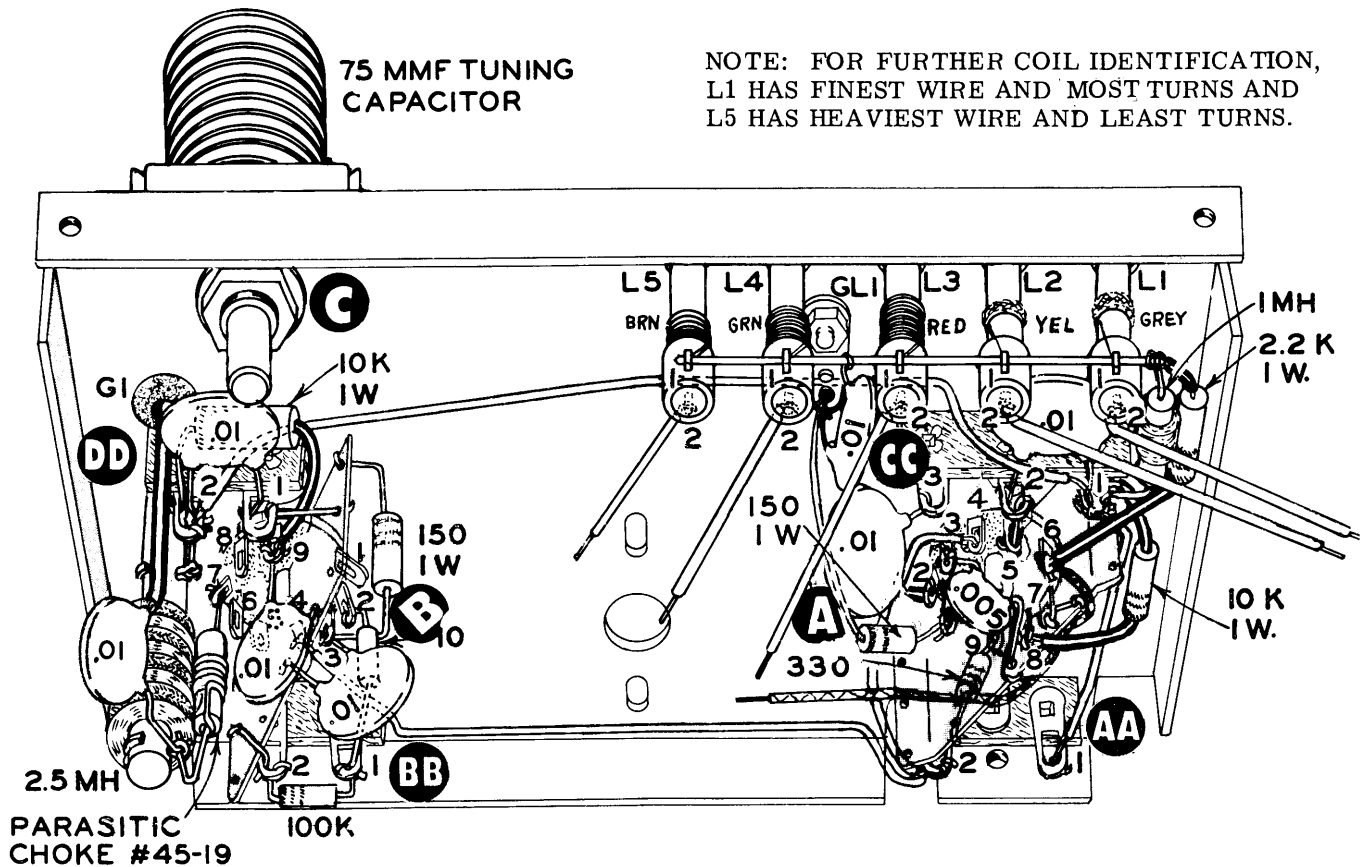

NOTE: FOR FURTHER COIL IDENTIFICATION, L1 HAS FINEST WIRE AND MOST TURNS AND L5 HAS HEAVIEST WIRE AND LEAST TURNS.

PICTORIAL 7

Refer to Pictorial 7 for all general wiring.

- ( ✓ ) Connect a 7/8" length of #20 bare wire from A5 (solder both shield and wire) to CC2 (NS).
- ( ✓ ) Connect a short length of #20 bare wire from DD1 (NS) to pin shield B (S).
- ( ✓ ) Connect a short length of #20 bare wire from BB2 (NS) to pin shield B (S).
- ( ✓ ) Solder B5 to the pin shield.
- ( ) Cut the leads of a 10 K $\Omega$  (brown-black-orange) 1 watt resistor to 3/4". Place a 1/2" length of sleeving on both leads and connect between CC1 (NS) and A8 (S1).
- ( ✓ ) Cut the leads of a 330 $\Omega$  (orange-orange-brown) 1/2 watt resistor to 3/8". Connect it between A9 (S1) and pin shield "A" (S1).
- ( ) Install a .005 mfd disc ceramic capacitor from A3 (S1) to pin shield "A" (S1).
- ( ✓ ) Cut one lead of a .01 mfd disc ceramic capacitor to 1/2". Place a 1/4" length of sleeving on this lead and connect it to A2 (S1). Connect the remaining lead of the capacitor to CC3 (NS). Trim excess wire.
- ( ✓ ) Strip the ends of a 2 1/4" length of hookup wire and connect it from A4 (S1) to AA2 (NS).
- ( ✓ ) Connect a 1" length of #20 bare wire from A7 (S1) to pin shield "A" (S1).
- ( ✓ ) Cut one lead of a 150 $\Omega$  (brown-green-brown) 1 watt resistor to 1/2" and connect to A1 (S1). Connect the other end to GL1 (NS). Dress as shown in Pictorial 7.

- (✓) Strip the ends of a 3" length of hookup wire. Connect one end to AA1 (NS). Connect the other end to CC1 (NS). Dress to chassis.
- (✓) Cut the leads of a .01 mfd disc ceramic capacitor to 3/8". Connect it between CC1 (NS) and CC2 (NS).
- (✓) Strip the ends of a 5" length of hookup wire. Connect from AA2 (NS) to B4 (S1).
- (✓) Strip the ends of a 6" length of hookup wire. Connect from CC1 (NS) to DD2 (NS).
- (✓) Cut the leads of a 100 K $\Omega$  (brown-black-yellow) resistor to 3/8". Connect one lead to BB1 (NS). Connect the other lead to BB2 (S2).
- (✓) Cut and dress the leads of a 150 $\Omega$  (brown-green-brown) 1 watt resistor as shown in Pictorial 7. Connect one lead to B3 (NS). Connect the other to the pin shield (S1).
- (✓) Cut the leads of a .01 mfd disc capacitor to 3/8" and connect between B3 (S2) and the pin shield (S1). Position as shown.
- (✓) Cut one lead of a 10 $\Omega$  (brown-black-black) 1/2 watt resistor to 3/8" and connect it to B2 (S1). Connect the other lead to BB1 (NS).
- (✓) Cut the leads of a .01 mfd disc ceramic capacitor to 3/8".- Connect one lead to B9 (NS). Connect the other lead to the pin shield "B" (S1) as shown in Pictorial 7.
- (✓) Cut one lead of a 10 K $\Omega$  (brown-black-orange) 1 watt resistor to 1 1/4". Connect this lead to B9 (S2). Position as shown and use sleeving.
- (✓) Cut the remaining lead of the above 10 K $\Omega$  resistor to 3/4" and connect it to DD2 (NS).
- (✓) Cut the leads of a .01 mfd disc ceramic capacitor to 3/8". Connect one lead to DD1 (S2) and the other lead to DD2 (NS).
- (✓) Mount the 2.5 mh RFC, 45-14, at the hole near DD2. Place a #6 lockwasher on the 6-32 x 3/8" RHMS and secure the RFC as shown, using a #6 fiber washer between the choke and the chassis. Be careful not to break ceramic form when securing.
- (✓) Using #20 bare wire, connect DD2 (S4) to RFC1 (S1).
- (✓) Connect the parasitic choke, 45-19, between B7 (S1) and RFC2 (NS).
- ( ) Identify each driver slug tuned coil by its color dot and insert it in its proper location on the chassis, as indicated in Pictorial 7. Orient each coil so its locating lug enters the locating hole provided.
- (✓) Connect one end of each of 5 lengths of hookup wire to lug 2 of each driver coil, as follows:
  - ✓ 4 1/4" length to L1-2 (S1) (80 meters)
  - ✓ 3 1/4" length to L2-2 (S1) (40 meters)
  - ✓ 2 3/4" length to L3-2 (S1) (20 meters)
  - ✓ 2 1/4" length to L4-2 (S1) (15 meters)
  - ✓ 2" length to L5-2 (S1) (10 meters)

Leave the other ends free temporarily.

- (✓) Insert a 2 3/4" length of #16 bare wire through the #1 lugs of all of the driver coils (L1 through L5). Solder each connection, except L1-1. Leave 3/8" of the wire extending from L1-1 for connection purposes.



- (✓) Cut one lead of a .01 mfd disc ceramic capacitor to 1/2", and connect it to GL1 (S2). Pass the other lead between L3 and L4 and solder it to the #16 bare wire which connects to #1 lug of all the driver coils. Trim off excess wire.
- (✓) Strip the ends of a 4" length of hookup wire. Connect one end to A6 (NS). Leave the other end free temporarily.
- (✓) Cut both leads of a 2.2 KΩ 1 watt (red-red-red) resistor to 1 1/4". Place a 1" length of sleeving on each of the leads and connect one to A6 (S2). Connect the other end to L1-1 (NS).
- (✓) Cut one lead of a 1 mh RF choke (45-3) to 1/2". Connect to CC1 (S5). Position as shown and connect the other lead to L1-1 (S3).
- (✓) Mount the tuning capacitor at "C" with the stator bars near socket B. A 3/8" control lock-washer is mounted on the bushing, then insert the capacitor in the 25/64" opening provided on the chassis. Secure with a nickel washer and 3/8" control nut.
- (✓) Cut one lead of a .01 mf disc ceramic capacitor to 3/4", connect to RFC2 (S2). Place a 3/4" length of insulating sleeving on the other lead. Pass it through grommet G1 and solder the lead to the variable capacitor stator near the grommet as shown in Detail 1. Trim excess wire.

NOTE: For the following steps, it will be necessary to combine the balanced modulator with the RF sub-assembly. Use care in assembling since the ceramic wafers in the band switch are fragile, and are susceptible to cracking in the event of undue strain.

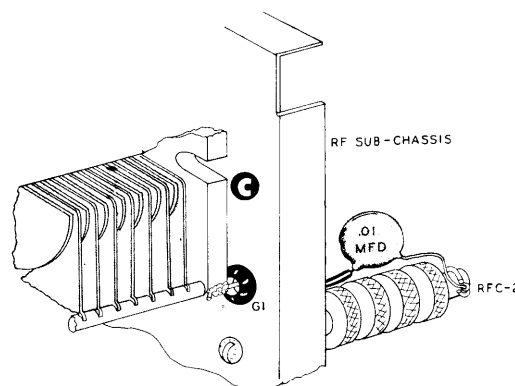

Detail 1

- (✓) Select the balanced modulator sub-chassis. Remove the first two spacers on each of the long bolts which hold the band switch assembly together. Referring to Figure 11 on page 34, properly orient the RF sub-assembly chassis and insert the band switch bolts and shaft through the openings at BS provided in the chassis. Replace the spacers and place the single wafer and coil assembly in place, as shown. Using wire cutters, clip and enlarge the coil mounting lugs if necessary. Secure with the hardware which was furnished with the switch. Observe very closely the orientation of the wafer rotor. Rotate it, if necessary to the position which the band switch is turned to. A small marker notch is located on the shaft hole of each rotor in the wafer. When properly assembled, all markers will "line up".
- (✓) Using #16 bare wire, connect the capacitor "C" stator terminal (S1) on the RF sub-chassis to the band switch BS5-6 (S1). See Detail 2.

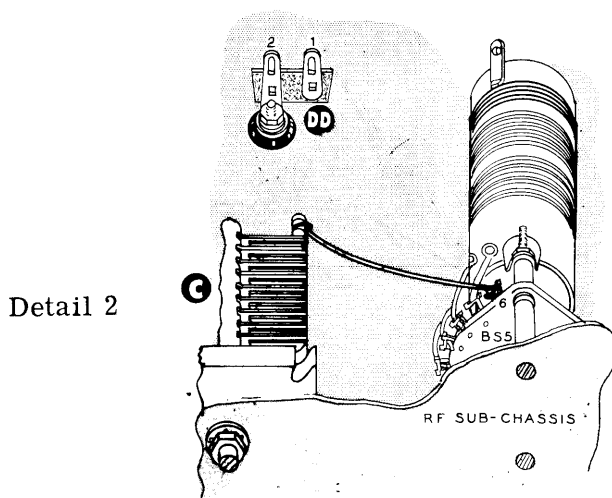

Detail 2

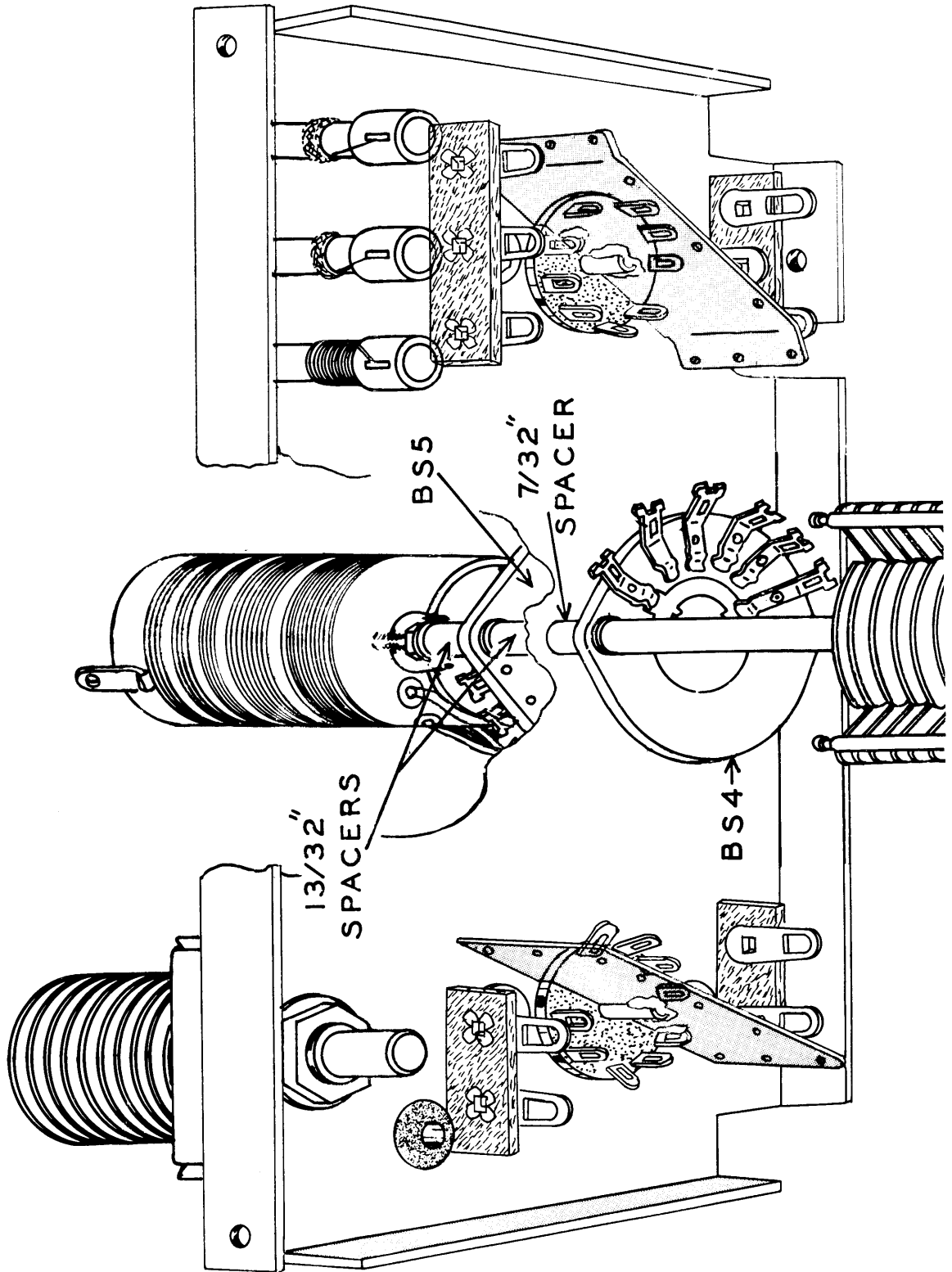

Figure 11

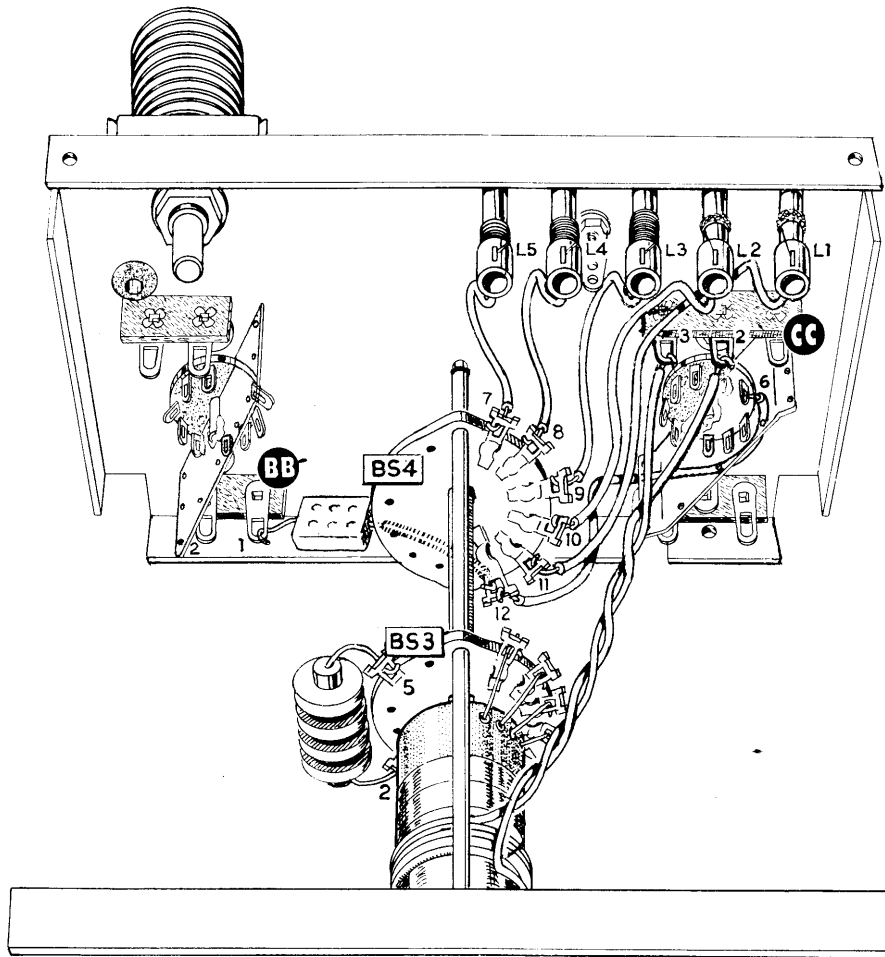

Figure 12

Refer to Figure 12 for the following steps:

- ( ) Connect the free ends of the leads which were previously connected to the #2 lugs of the driver coils as follows; observing lead dress carefully:

- Connect L1-2 to band switch BS4-11 (S1).
- Connect L2-2 to band switch BS4-10 (S1).
- Connect L3-2 to band switch BS4-9 (S1).
- Connect L4-2 to band switch BS4-8 (S1).
- Connect L5-2 to band switch BS4-7 (S1).

- ( ) Cut the leads of a 68 mmf mica capacitor to 1". Connect one lead to terminal strip BB1 (S3). Place a 3/4" length of insulating sleeving on the other lead and connect it to BS4-12 (NS). Dress against chassis flange.
- ( ) Connect the free end of the wire from A6 to BS4-12 (S2).
- ( ) Connect one lead of the 4 3/4" twisted pair link of the balanced modulator coil to CC3 (S2). Connect the other lead to CC2 (S3). Trim excess lead length.
- ( ) Install a 1.1 mh RF choke (45-4) on wafer #3 by connecting one end to BS3-2 (S), and the other end to BS3-5 (NS).

This will complete all external wiring on the RF Sub-Assembly. Recheck your work and set the chassis aside temporarily.

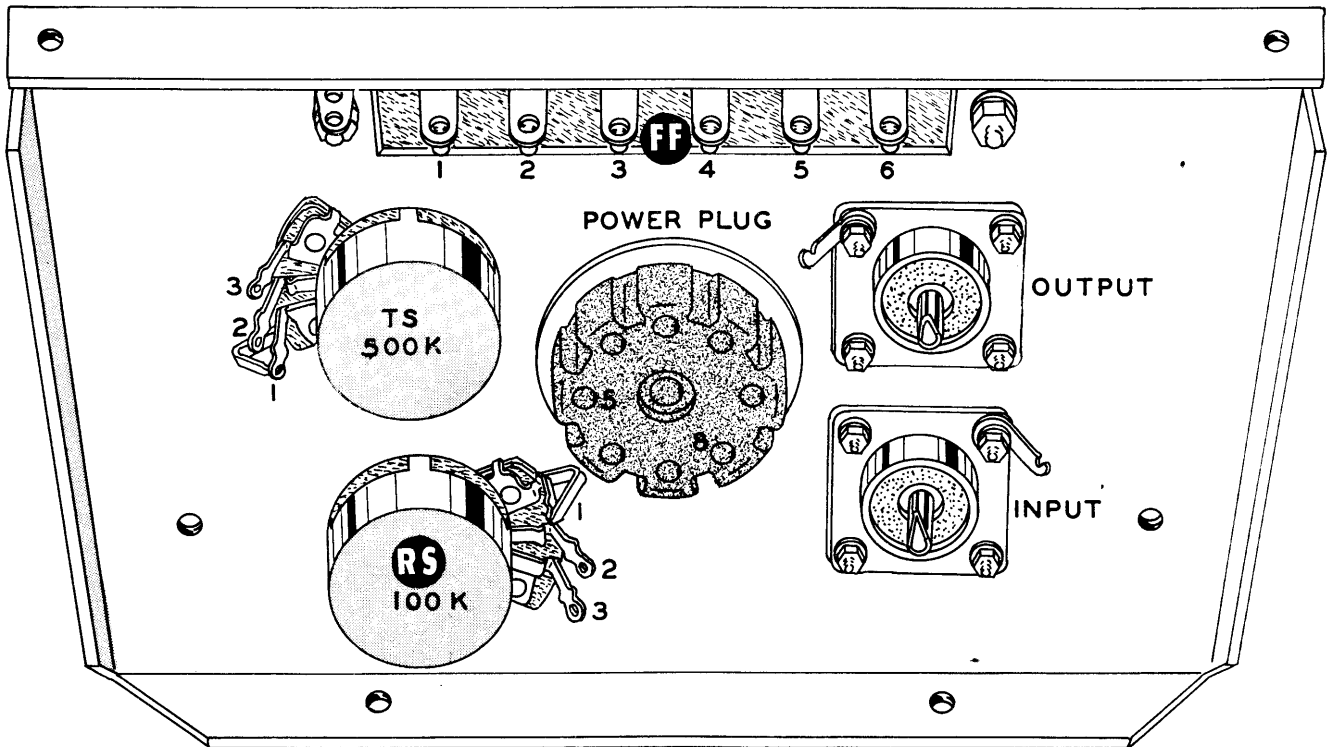

PICTORIAL 8

REAR CHASSIS APRON ASSEMBLY AND WIRING

Refer to Pictorials 8 and 9 for component mounting and wiring.

- ( ) Select the 100 K $\Omega$  control. Place a 3/8" control ground lug on the bushing. Install the control at "RS" on the apron and orient as shown, with the ground lug positioned under terminal 1 of the control. Secure the control to the apron with a nickel panel washer and a 3/8" control nut.
- ( ) Mount a 500 K $\Omega$  control at "TS" in a similar manner but place a 1/8" thick control washer on the control bushing after the control ground lug.
- ( ) Mount the coax connectors as shown. Use 3-48 BHMS, #3 lockwashers, 3-48 nuts. Secure a small #6 ground lug on each connector, as shown. Note the connectors are mounted from the inside of the apron.
- ( ) Install the 6 lug (screw type) terminal strip on the outside of the chassis at location FF. Secure it with #6-32 hardware. Use a #6 ground lug and a 6-32 nut on the end nearest #1 terminal. Orient ground lug as shown.
- ( ) Install the male octal power plug in the large hole. Press the locking ring in place around the plug to secure. Orient as shown with pin 8 near the input coaxial connector.
- ( ) Connect a 1 1/2" length of #20 bare wire from FF2 (S1) to the ground lug near FF1 (S1). Refer to Pictorial 9.
- ( ) Strip the ends of a 7" length of hookup wire. Connect one end to FF1 (S1). Dress as shown and leave the other end free temporarily.
- ( ) Strip the ends of an 8 1/2" length of hookup wire. Connect one end to FF3 (S1). Dress as shown. Leave the other end free temporarily.

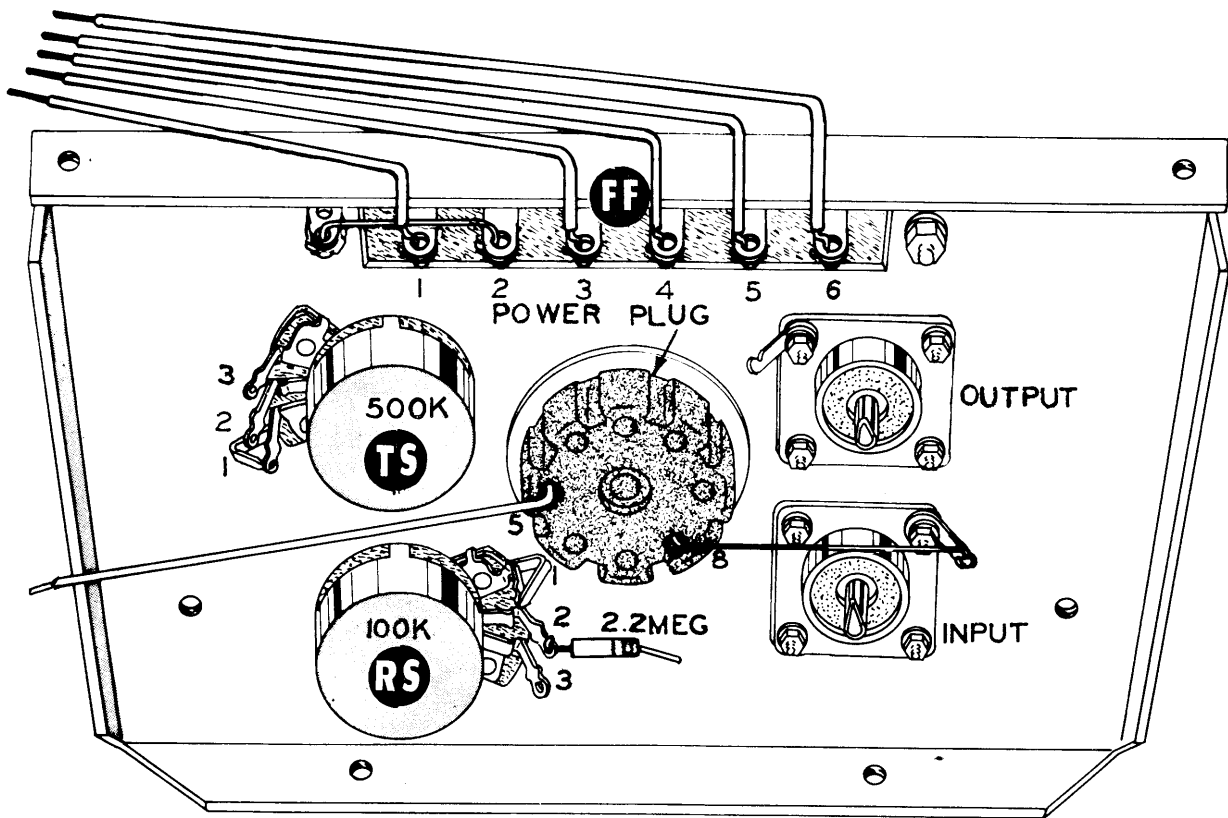

PICTORIAL 9

- (✓) Strip the ends of a 9" length of hookup wire. Connect one end to FF4 (S1). Dress as shown. Leave the other end free temporarily.
- ( ) Strip the ends of a 9" length of hookup wire. Connect one end to FF5 (S1). Leave the other end free temporarily.
- (✓) Prepare the ends of a 9 1/2" length of hookup wire. Connect one end to FF6 (S1). Leave the other end free temporarily.
- ( ) Cut a 6 1/2" length of hookup wire. Prepare both ends and connect one of them to pin #5 of the octal power plug (S1). Leave the other end free temporarily.
- (✓) Cut a 2 3/4" length of #20 bare wire. Connect one end to pin #8 of the octal power plug (S1). Connect the other end to the near coax connector ground lug (NS).
- (✓) Bend, cut and solder the ground lugs to terminal 1 of each of the 100 KΩ controls at "TS" and "RS".
- (✓) Cut both leads of a 2.2 megohm (red-red-green) 1/2 watt resistor to 3/8". Connect one lead to RS2 (S1). Leave the other end free temporarily.

This completes the rear chassis apron preliminary wiring. Recheck your work and set the chassis aside temporarily.

#### FINAL ASSEMBLY

Before starting the final assembly of the adapter, go back and check the wiring of all sub-chassis. After assuring yourself that the "step-by-step" procedure on each of the units was followed without error, the sub-chassis are ready for final assembly.

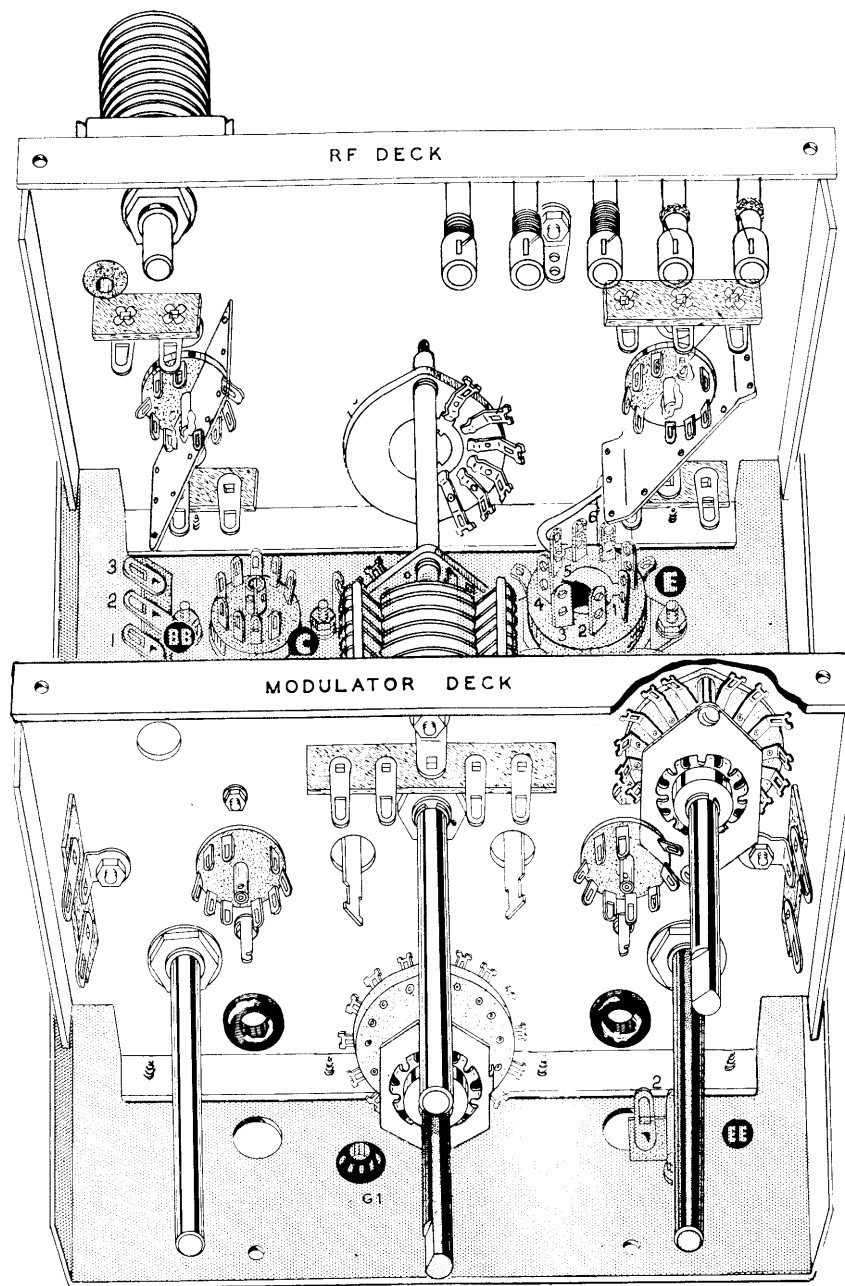
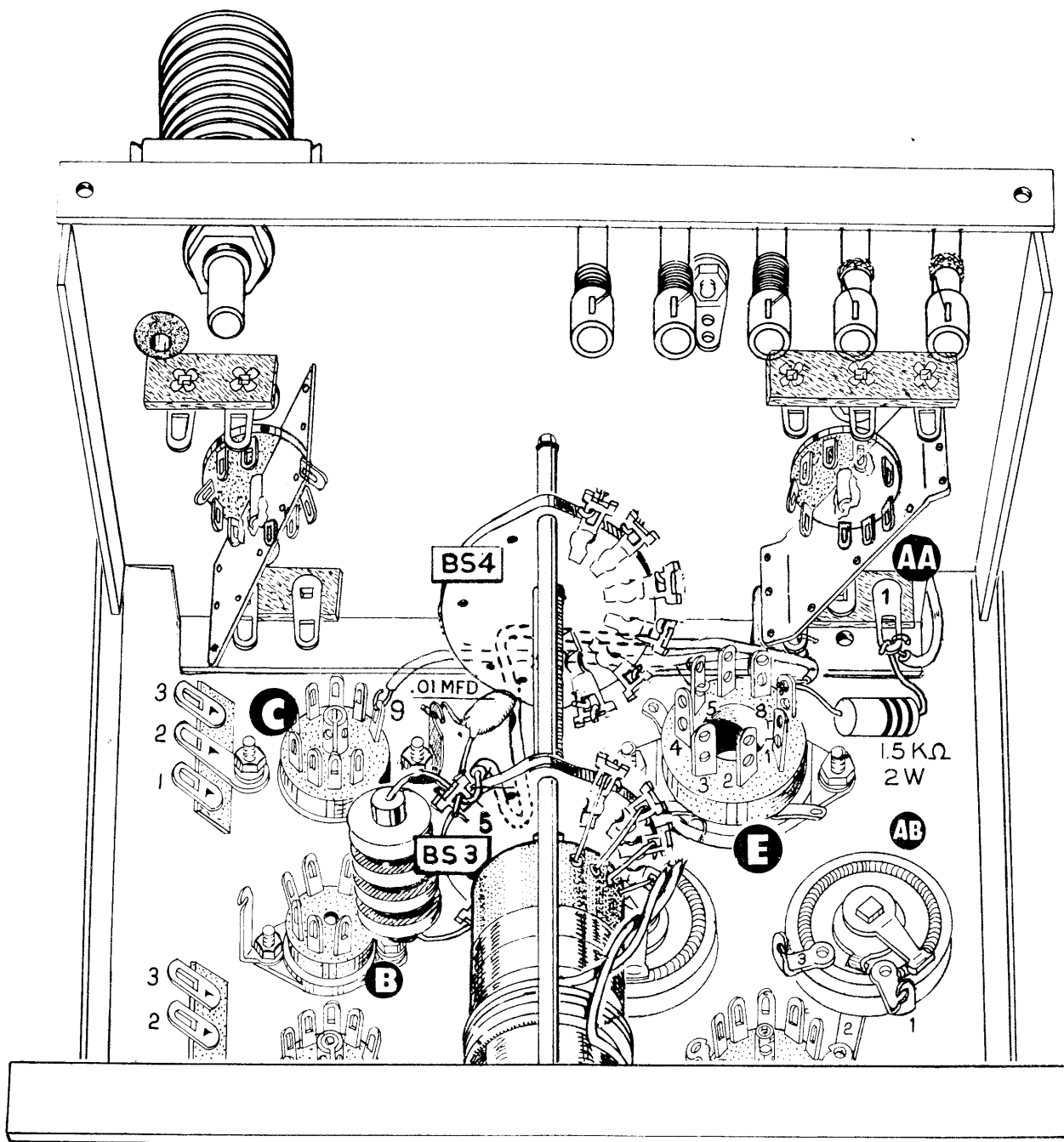

Figure 13

- ( ) Place the audio and phasing deck in front of you upside down. The deck should have the outlines of the sub-chassis drawn on it, as was outlined in the step-by-step of the audio and phasing deck. All wiring should be dressed away from these lines in preparation to securing the sub-assemblies to the deck.
- ( ) Carefully place the balanced modulator and the RF sub-chassis in place as shown in Figure 13.
- ( ) Holding the balanced modulator and the RF sub-chassis in place, turn the unit over and secure the balanced modulator sub-chassis by using #6 sheet metal screws through each of the mounting feet of the modulation transformers. (Remove the #6 hardware used for temporary mounting.) The screws are of the self tapping type, and it will be necessary to exert a small amount of pressure for starting the screws. Do not tighten.
- ( ) Fasten the RF sub-chassis to the audio deck by using 2 #6 sheet metal screws. Do not tighten. Pull both sub-chassis toward the front of the deck. Now tighten the metal screws. Check to make sure the pin shield on socket "B" on the RF sub-chassis is not touching lug 3 of terminal strip BB on the audio deck, or that the "A" shield is not touching any of the socket "E" lugs.



PICTORIAL 10

- (✓) Strip the ends of a 4" length of hookup wire. Connect one end to C9 (audio deck) (S2), and the other end to AA2 (RF sub-chassis) (S3). See Pictorial 10.
- (✓) Strip the ends of a 5 1/2" length of hookup wire. Connect one end to pin 8 of socket "E" (audio deck) (NS). Dress the lead as shown and connect the other end to BS3-5 (balanced modulator coil and wafer assembly) (NS). See Pictorial 10.
- (✓) Cut one lead of a .01 mfd disc ceramic capacitor to 1" and connect it to the ground lug of socket "C" (audio deck) (S2). Connect the remaining end to BS3-5 (S3). Trim excess wire. See Pictorial 10.
- (✓) Trim the leads of a 1.5 KΩ (brown-green-red) 2 watt resistor to length and connect the resistor between terminal strip AA1 (RF sub-chassis) (NS) and pin 8 of socket "E" (audio deck) (S2).
- (✓) Strip the ends of a 12" length of hookup wire. Connect one end to the terminal strip AA1 (RF sub-chassis) (S3). Dress as shown through G3 and connect to RY3 (S1). See Pictorial 10 and Pictorial 12 on Page 41.

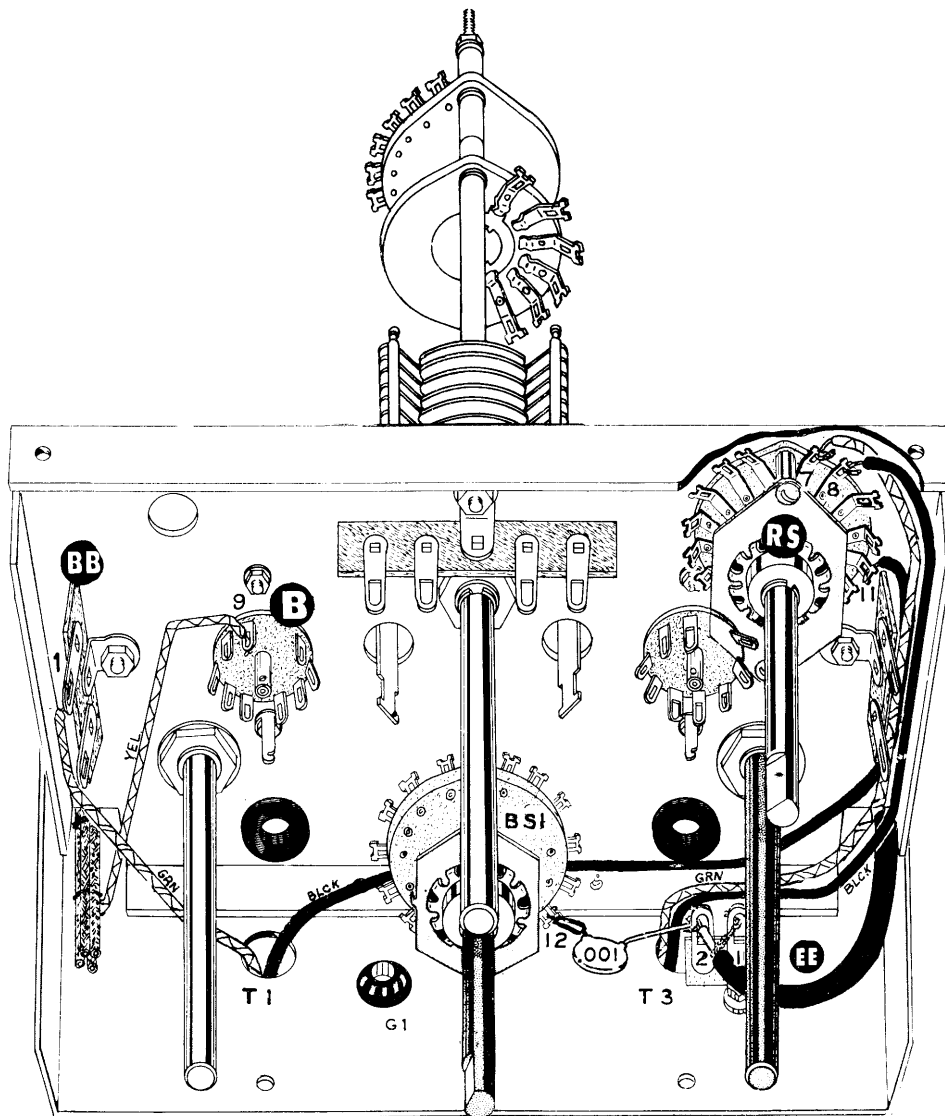

Pictorial 11

Refer to Pictorial 11 and connect the modulation transformers T1 and T3 as instructed below. It is very important to dress wires as shown.

- (✓) Connect the green wire of T1 to BB1 (bal. mod. chassis) (S3).
- (✓) Connect the black wire of T1 to RS-11 (bal. mod. chassis) (S2).
- (✓) Connect the green wire of T3 to RS-7 (bal. mod. chassis) (S2).
- (✓) Connect the black wire of T3 to RS-8 (bal. mod. chassis) (S2).
- (✓) Connect the yellow wire (breakout #2) of the shielded wire harness to B9 (S2) of the balanced modulator sub-chassis. See Pictorial 11.

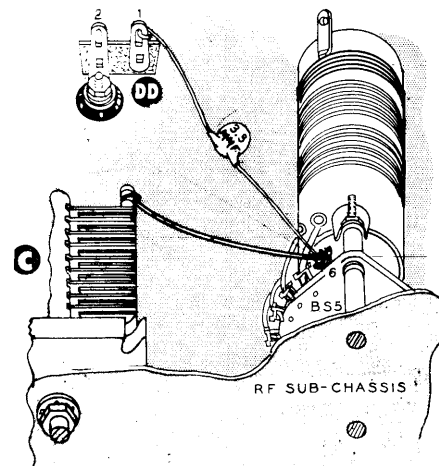

Detail 3

- (✓) Cut the leads of a 3.3 mmf disc ceramic capacitor to 1 1/2". Connect one lead to DD1 (S2) audio deck. Connect the other lead to the #16 bare wire near BS5-6 and solder. See Detail 3.



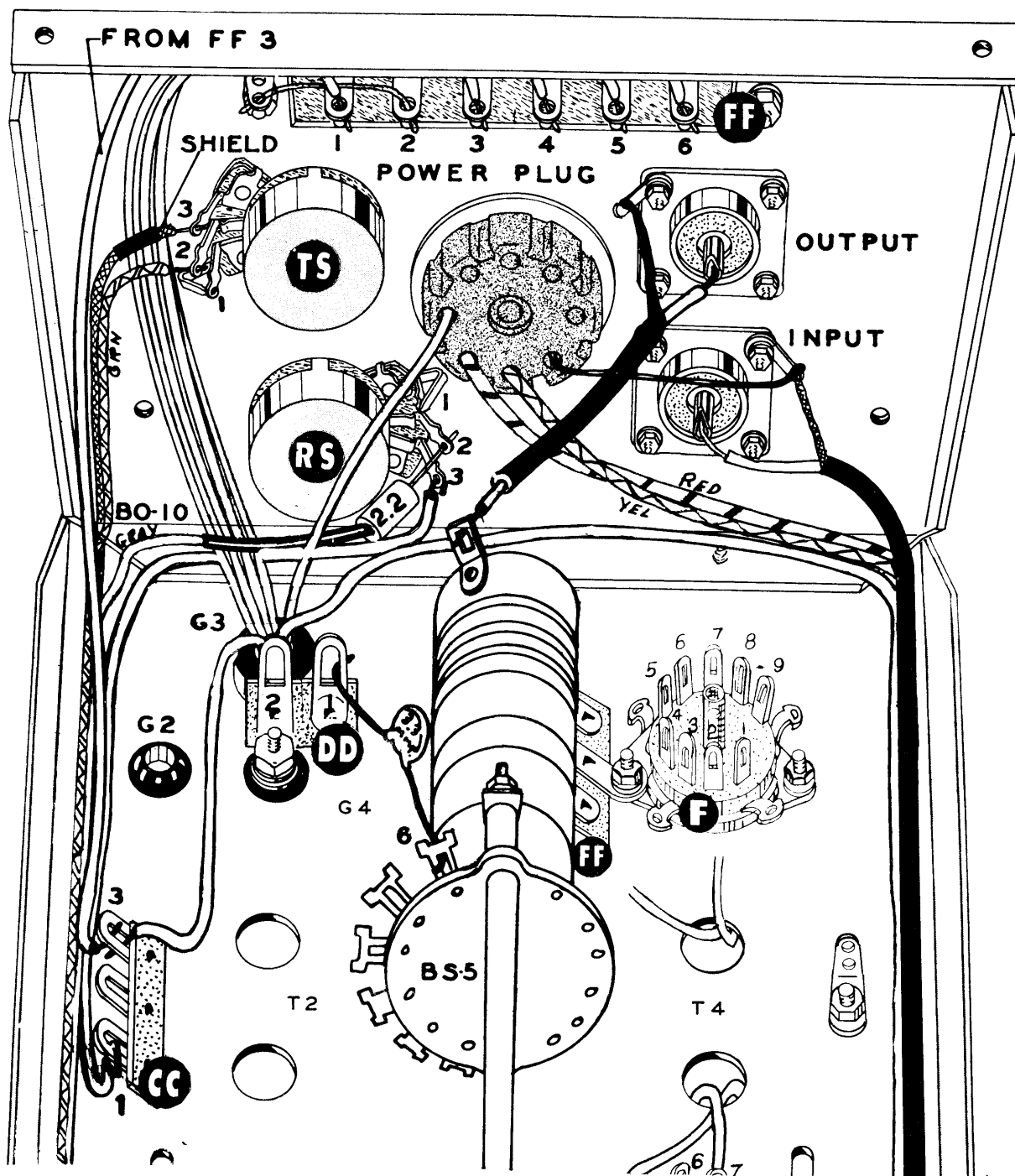

Pictorial 12

Refer to Pictorial 12 for the following steps:

- ( ) Dress all wires from the rear chassis apron except the one connected to FF3 through grommet G3.
- ( ) Secure the rear chassis apron to the audio deck. Use two #6 sheet metal screws.
- (✓) Place a 1/2" length of sleeving on the gray wire at breakout point #10 of the shielded wire harness. Form a small hook in the wire and connect it to a similar hook made at the free end of the 2.2 megohm resistor, which has one end connected to the transmitter sensitivity control RS2. Pinch the loops together and solder. Now slide the sleeving over the connection and dress as shown.

- ( ) Strip the ends of a 6" length of hookup wire. Connect one end to the receiver sensitivity control RS3 (S1). Dress as shown and connect the other end to terminal strip CC1 (S2) on the audio deck.
- ( ) Connect the green wire in the shielded wire harness to the transmitter sensitivity control TS2 (S1) on the rear apron.
- ( ) Connect the shielded wire to TS3 (S1).
- ( ) Connect the yellow wire in the function wiring harness (no shielded wires) to pin #7 (S1) of the octal power plug.
- ( ) Connect the red wire of the function wiring harness to pin 6 (S1) of the octal power plug.

Connect all wires which were inserted through G3 to points indicated below.

NOTE: A slight pull on each wire, as it is needed, will identify it. Dress wires exactly as shown.

- ( ) Connect the wire from the octal power plug pin #5 to the relay terminal RY14 (S1).
- ( ) Connect the wire from FF1 to RY12 (S1).
- ( ) Connect the wire from FF4 to RY15 (S1).
- ( ) Connect the wire from FF5 to RY7 (S1).
- ( ) Connect the wire from FF6 to RY5 (S1).

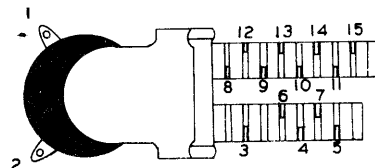

- ( ) Trim one lead of the 10 $\Omega$  1 watt (brown-black-black) resistor to 1/2" and, as shown in Figure 15 on page 47, connect to RY9 (S1). Use sleeving. Pass the other end through RY11 (NS) to RY10 (S1). Now solder RY11 (S2).
- ( ) Connect the wire from FF3 to CC3 (S3) on the audio deck.
- ( ) Cut a 2 3/8" length of RG58A/U coaxial cable and strip 3/8" of the outside covering and braided shield from one end. Strip 5/8" of outside covering from the other end of the coax but do not cut the shield. Unbraid the shield with a pointed instrument. Remove about 3/16" of insulation from each end of the center conductor.
- ( ) Slightly twist the unbraided shield and connect it to the ground lug on the output connector and solder. Connect the center conductor of the coax to the center terminal of the output connector (S1).
- ( ) Connect the center conductor of the other end to the output lug at the end of the RF tank coil (S1).
- ( ) Cut a 13" length of RG58A/U coax. Strip 3/4" of the outside covering from one end. Unbraid the shield and twist it to form a lead. Remove 3/16" of insulation from the center conductor. Repeat this same procedure at the opposite end. Route the coax through the openings in the sub-chassis and along the audio deck side apron in the same manner as the unshielded harness. Connect the center conductor to EE2 (NS). Connect the shield of the coax to EE1 (S1). Refer to Pictorials 11 and 12.
- ( ) Connect the loose end of the .001 mfd disc ceramic capacitor connected to the band switch wafer on the balanced modulator chassis (BS1-12) to EE2 (S2) of the audio deck. See Pictorial 11.

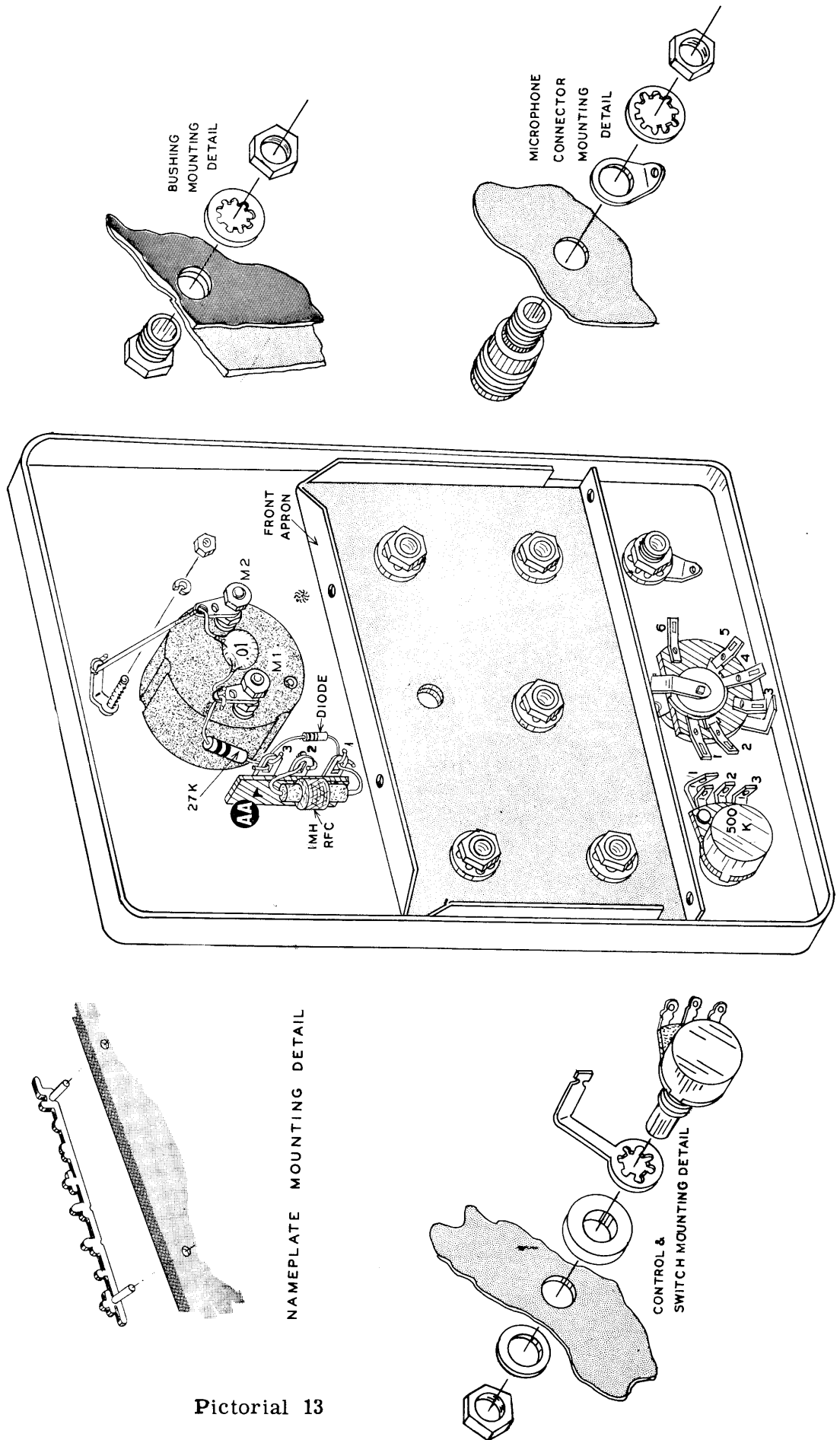

Pictorial 13

- (✓) Connect the center conductor of the other end of the coax to the center terminal of the input coax connector (S1). See Pictorial 12.
- (✓) Connect the shield of the coax to the ground lug on the input connector (rear apron) and solder (S2). See Pictorial 12.

Lay the nearly completed assembly aside until the front chassis apron and panel assembly is completed.

### ASSEMBLING THE PANEL

- (✓) Remove the panel from its wrapping.
- (✓) Locate the front chassis apron, five brass panel bushings, five 3/8" control lockwashers, and five 3/8" control nuts.

NOTE: During assembly, be careful not to mar the panel. Refer to Pictorial 13 on page 43 for assembly and wiring.

- ( ) Lay the front chassis apron in place on the back of the panel, as shown, and install the bushings through the front of the panel at the locations shown. Do not place a bushing at the band switch location. Use a 3/8" lockwasher and 3/8" control nut to secure. Do not tighten the nuts until all bushings have been installed.
- (✓) Remove the nut and solder lug from the microphone connector and insert the connector at the panel location marked MICROPHONE. Secure it with an extra 3/8" lockwasher plus the solder lug and nut which was furnished with the connector.
- (✓) Place a 3/8" control ground lug and a thick 3/8" washer on the bushing of the function switch. Insert it from the rear of the panel. Use a nickel panel washer and a 3/8" nut to secure. Orient the ground lug near terminal #3 of the switch and tighten the nut.
- (✓) Place a 3/8" control ground lug and a thick 3/8" washer on the bushing of a 500 K $\Omega$  control and insert it through the panel at the AUDIO GAIN location. Orient the control solder lug nearest terminal #1. Use a nickel panel washer and 3/8" control nut for securing.
- (✓) Mount the "Heathkit" nameplate as shown, in the two small holes provided. Hold it tight against the panel and trim the studs to 1/4". Now touch the plastic pins on the back of the panel with a soldering iron, melting the plastic to form a retaining shoulder.
- (✓) Mount the meter. Use the lockwashers and nuts furnished with the meter. Install a 3 lug, one ground terminal strip as shown in Pictorial 13 on page 43, at the bottom left meter stud. Mount a #6 (small) ground lug at the top meter stud.
- ( ) Place a #8 solder lug on both meter lugs and secure as shown with the #8-32 nuts supplied.
- (✓) Cut one lead of a .01 mfd disc ceramic capacitor to 3/4". Connect this lead to M1 (NS). Pass the other lead through M2 (NS) to the ground lug at the top of the meter (S1). Now solder M2 (S1).
- (✓) Connect a 27 K $\Omega$  (red-violet-orange) 1/2 watt resistor from M1 (S2) to AA3 (NS).

NOTE: When soldering diodes, grasp the lead to be soldered with long nose pliers. The pliers will absorb the heat and prevent damage to the diode.

- ( ) Cut both leads of the diode to 1/2". Connect the cathode lead (color bands) to AA3 (S2). Connect the other lead to AA1 (NS).
- (✓) Connect a 1 mh RF choke (45-3) from AA2 (S1) to AA1 (NS).

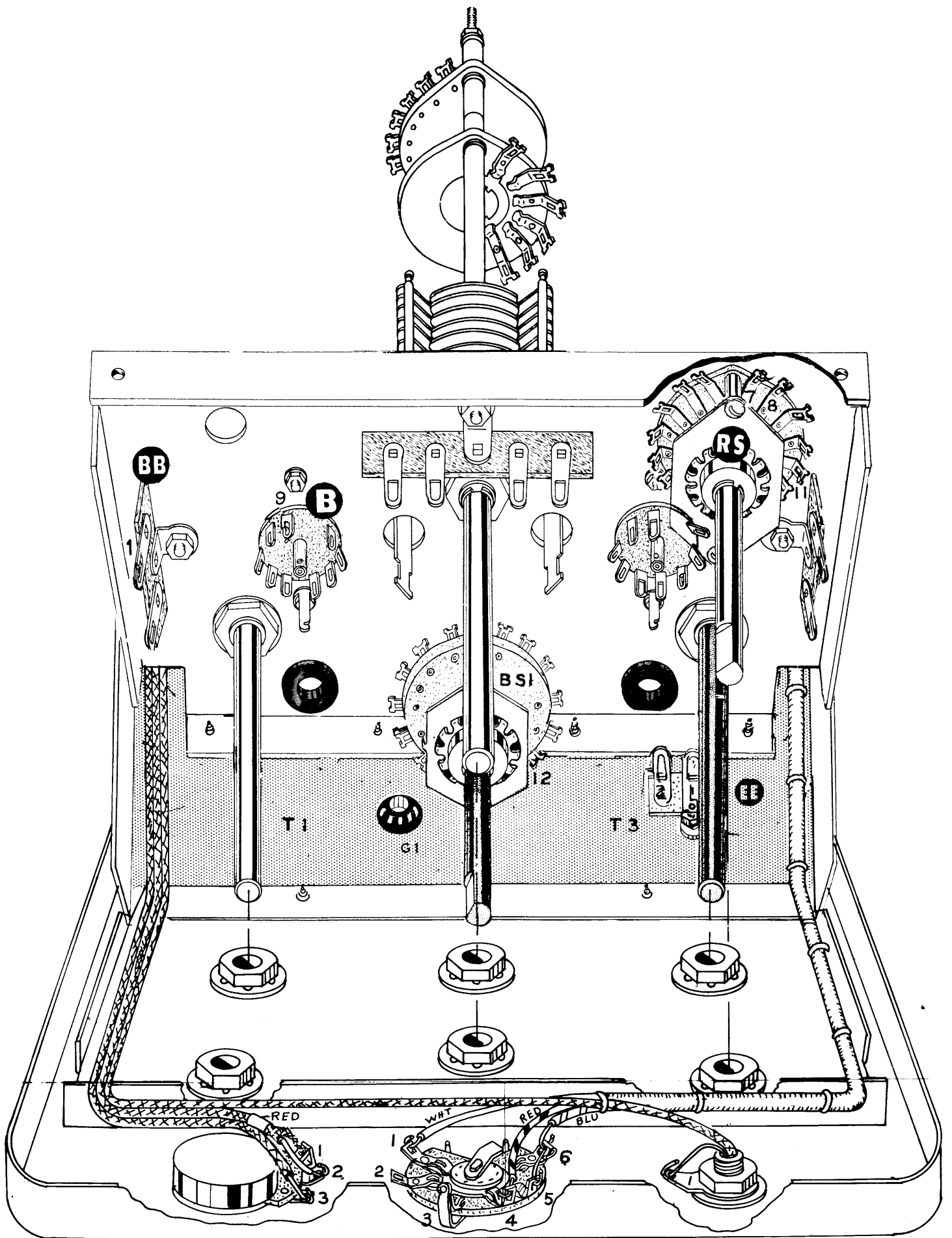

Figure 14

Refer to Figure 14 on page 45 for the following steps:

- ( ) Mount the panel and assembly to the chassis. Carefully start the protruding control shafts through the panel bushings. Continue sliding the panel down until the audio deck is tight against the panel.
- ( ) Secure the deck to the front apron with two #6 sheet metal screws, as shown.
- ( ) Place the unit so it rests on the panel face. Place a rag under the panel for protection. Proceed with wiring of the controls.
- ( ) Separate the two short shielded leads from the long one in the shielded wire harness.
- ( ) Connect the center conductor of the shielded lead which is coded RED to audio gain control terminal #2 (S1).
- ( ) Connect the center conductor of the second shorter shielded lead to audio gain control terminal #3 (S1).
- ( ) Dress the long shielded lead as shown and connect the center conductor to the center of the microphone connector (S1). Connect the shield pig-tail to the ground lug at the microphone connector (S1).
- ( ) Bend the control ground lug of the audio gain control so that it is touching terminal #1. Connect the shield pig-tails from the shielded wires at terminals 2 and 3 to terminal 1 and solder entire connection (S3).

Connect the other wires from the function harness to the function switch as follows:

- ( ) White to terminal #1 (S1) of the function switch.
- ( ) Red to terminal #4 (S1) of the function switch.
- ( ) Blue to terminal #6 (NS) of the function switch.
- ( ) Connect a 1 1/4" length of #20 bare wire from terminal #6 (S2) to #5 (S1) of the function switch.
- ( ) Bend and connect the ground lug to terminal #3 (S1) of the function switch.
- ( ) Install the two reinforcing angle brackets along the bottom corners of the sub-chassis pieces and the front and rear aprons. Use #6 sheet metal screws. Notice the brackets are interchangeable; either will fit at each location. Before securing, make sure the sub-chassis pieces, the rear apron and the front panel are all perpendicular to the audio deck. See the under chassis photograph at the rear of the manual.
- ( ) Install the 6 11/16" shaft extension through the OUTPUT bushing and secure to the output tuning capacitor with an insulated coupling. Leave 3/8" of the shaft extending from the front panel bushing. Use #8-32 x 1/8" slotted set screws on the coupling.

- ( ) Place the chassis in its normal upright position and connect the shielded wire which is protruding through G1 (Audio Deck) to AA1 on the panel (S3). See Figure 15.

Place the tubes in their respective sockets as follows:

- ( ) Two 12AT7 tubes in the sockets on the balanced modulator sub-chassis. Place one of the smaller tube shields over each tube.
- ( ) A 6CL6 in the socket on the RF deck directly above the driver coils. Place the larger tube shield over the tube.
- ( ) An EL84/6BQ5 in the socket on the RF deck above the final tuning capacitor. No tube shield is used.

See Figure 15 for the following tube placements:

- ( ) A 12AX7 in the socket to the rear of T1, using a small tube shield.

Figure 15

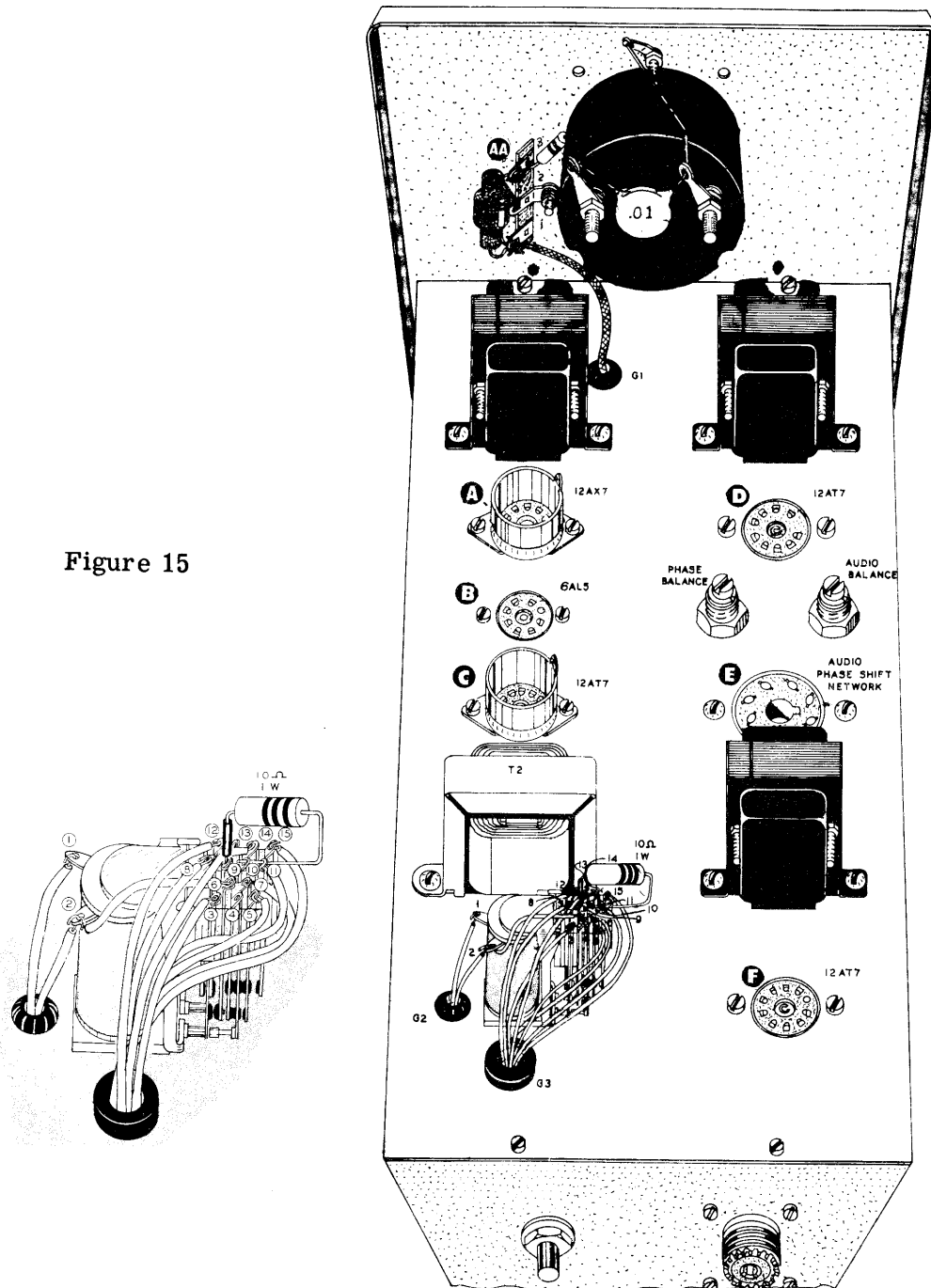

- (✓) A 6AL5 in the socket next to the 12AX7.
- ( ) A 12AT7 in the socket between the 6AL5 and T2, using a small tube shield.
- ( ) A 12AT7 in the socket behind T3.
- ( ) A 12AT7 in the socket to the rear of T4.
- ( ) Insert the audio phase shift network in the octal socket "E" located between T4 and the balance controls.
- (✓) Install 2 small plastic knobs on the sensitivity ("Receiver" and "Transmitter") controls located on the rear chassis apron.

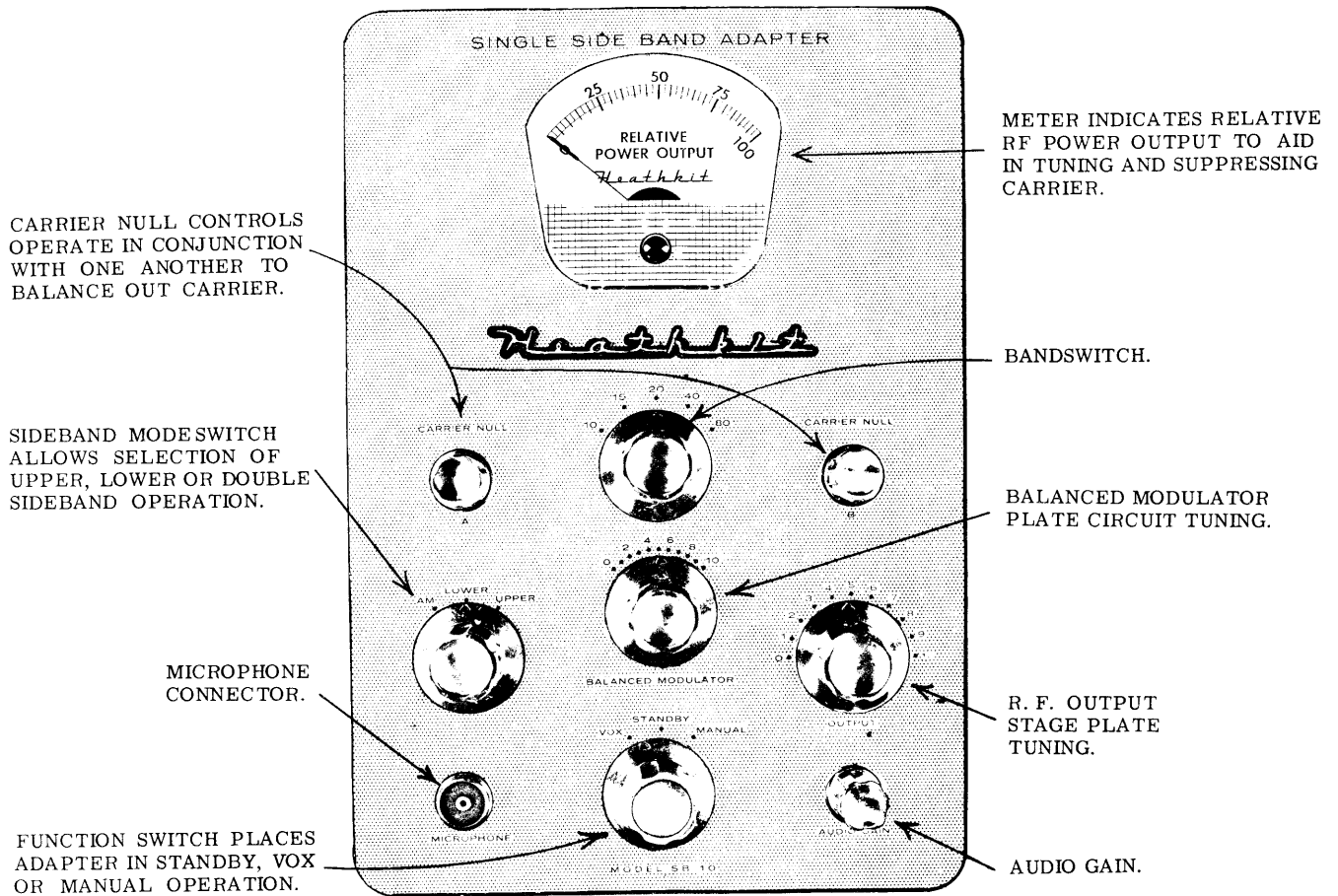

Figure 16

Refer to Figure 16 for the following steps:

- ( ) Install small aluminum knobs on the CARRIER NULL controls. Turn the controls full CCW and orient the pointer to full CCW position. Use #8-32 x 1/8" allen head setscrews.
- ( ) Install a small aluminum knob on the AUDIO GAIN control. Turn the control full CCW and orient the pointer to the full CCW position. Use a #8-32 x 1/8" allen head setscrew.
- ( ) Turn the side-band reversing switch to the AM position. Install one of the skirted aluminum knobs with the pointer indicating AM. Use #8-32 x 1/4" allen head setscrews to secure the knob in this and the next three steps.
- ( ) Turn the rotor plates of the balanced modulator and output tuning capacitor fully open. Install a skirted aluminum knob with its pointer indicating zero on each variable capacitor shaft.
- ( ) Rotate the band switch full counterclockwise and install a skirted aluminum knob to indicate 10 meters.
- ( ) Turn the function switch to its center position and install a skirted knob with its marker indicating STANDBY.
- ( ) Lubricate the panel bushings with light machine oil to prevent the control shafts from binding.

This completes assembly and wiring of your SB-10. Some small hardware may be left over. This is intentional to prevent shortages due to losses in volume handling.



## INSTALLATION

Before the Model SB-10 Single Sideband Adapter can be tested, adjusted, and put into actual operation, it will be necessary to make up the necessary connecting cables and modify your present transmitter for use with the adapter. No transmitter modification is necessary if the Heathkit "Apache" Model TX-1 is used as the companion transmitter to the SB-10, since the two units are designed to be completely compatible.

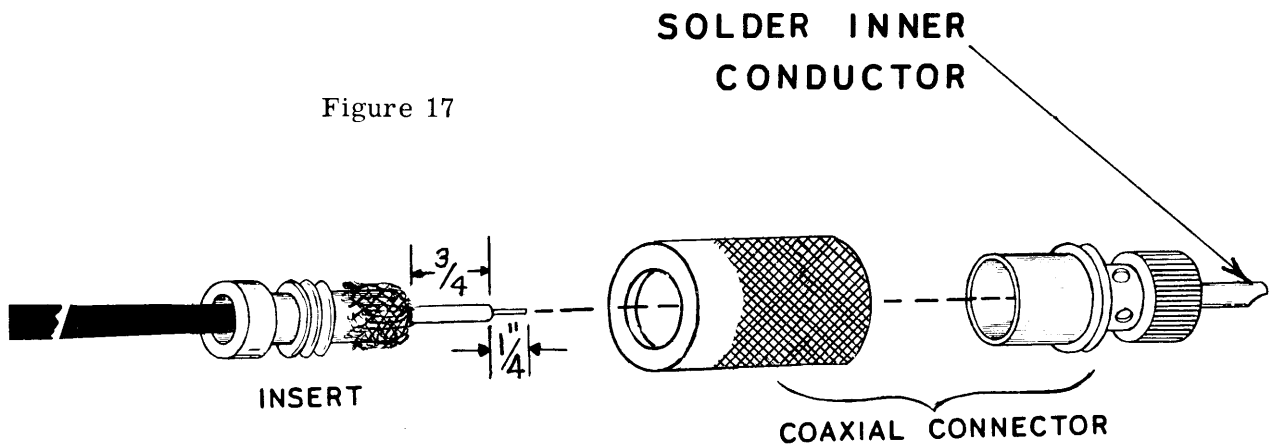

Prepare the connecting cables as outlined in the following steps:

- (1) Cut the remaining length of coaxial cable into two equal parts. Each piece should be approximately 3' long. Locate the four male coaxial cable connectors and adapters. Referring to Figure 17, place a connector on each end of both lengths of coaxial cable.

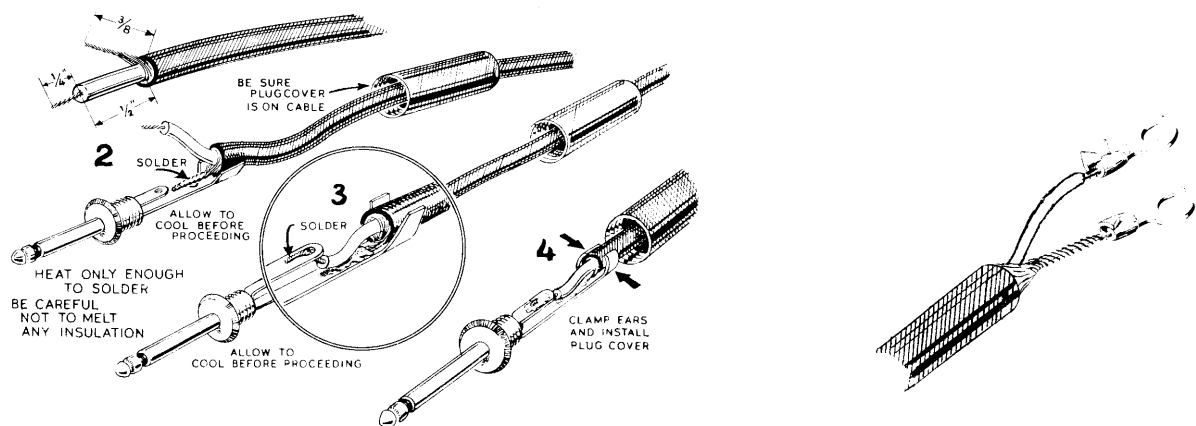

- (2) Locate the length of single conductor shielded wire. Referring to Figure 18, strip the outer jacket off one end for a distance of 1", unwind the shield wire, twist and tin. Strip and tin  $3/8$ " of the center conductor. Now solder a terminal spade lug on each tinned lead. On the other end of the shielded wire, place a phone jack as shown.

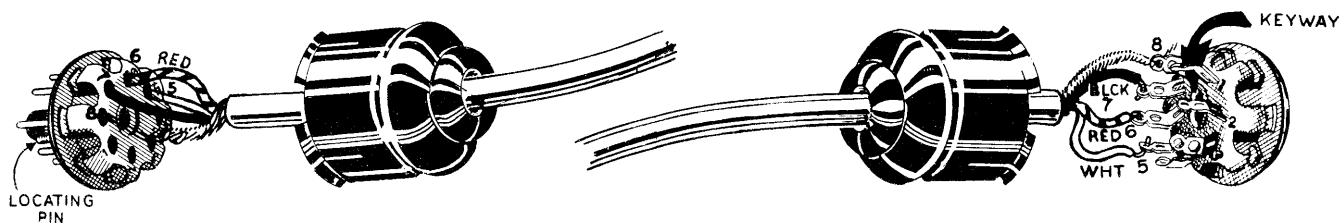

Figure 19

- ( ) Locate the length of 3 conductor shielded cable. Referring to Figure 19, strip the outer jacket for a distance of 1" from each end of the cable. Then unbraid and twist the shield into a pigtail. On one end, strip and tin each wire for a distance of 3/8". Slide an octal socket cap over this end and connect the white lead to pin 5, the red to pin 6, the black to pin 7, and the shield to pin 8 of a female octal socket. Now snap the cover into place. At the other end, strip and tin each lead for a distance of 1/2". Slide an octal plug cover over the cable. Connect the white lead to pin 5, the red to pin 6, and the black to pin 7 of a male octal plug. Using a short length of #20 bare wire, connect the shield to pin 8. Trim off any excess shield. Now snap the cover into place.

To connect the adapter to the Heathkit "Apache" Model TX-1 Transmitter, connect one coaxial cable between the connector on the back of the transmitter marked "RF Excitation to SSB Adapter" and the "RF Excitation Input" connector on the adapter. Connect the other coaxial cable between the connector on the back of the transmitter marked "SSB Input to Final" and the "SSB Output" connector on the adapter. Plug the female end of the shielded power cable into the adapter and the male end into the transmitter accessory socket. Now connect the center conductor spade terminal on the single conductor shielded wire to terminal strip lug #4 on the back of the adapter and connect the shield to terminal #2. Plug the phone jack on the other end of the wire into the key jack on the front of the transmitter. After connecting a dummy load to the RF output connector of the transmitter and making sure the proper AB1 operating conditions have been set up in the "Apache" (see the Model TX-1 Manual), the SB-10 is ready for testing and adjustment.

If the SB-10 is intended for use with Heathkit Model DX-100 or DX-100B Transmitter, a modification of these units is necessary. A single modification kit applicable to either the DX-100 or DX-100B can be purchased from the Heath Company. This kit contains all necessary components and hardware and is supplied with complete and detailed instructions. However, the modification is not complex and since most "junk boxes" will furnish the necessary parts, the information on the modification is included here.

Three basic changes are made in the DX-100 and DX-100B when modifying these transmitters for SSB operation. First, the RF path is broken between the output circuit of the driver (5763) stage and the grids of the final amplifier (2-6146). The drive is brought out to a coaxial connector on the rear of the chassis. The final amplifier grid lead is also brought out to a second coaxial connector on the rear of the chassis. Second, the final amplifier is placed in Class AB1 for

linear operation. The final amplifier screen voltage is regulated at 210 volts with two OB2 voltage regulator tubes in series. The bias is then adjusted to give 50 ma of resting plate current. Third, a provision is made for lifting the ground end of the fixed bias resistor string during standby periods to cut off the final amplifier without removing plate voltage. This eliminates excessive switching of plate transformer primary power.

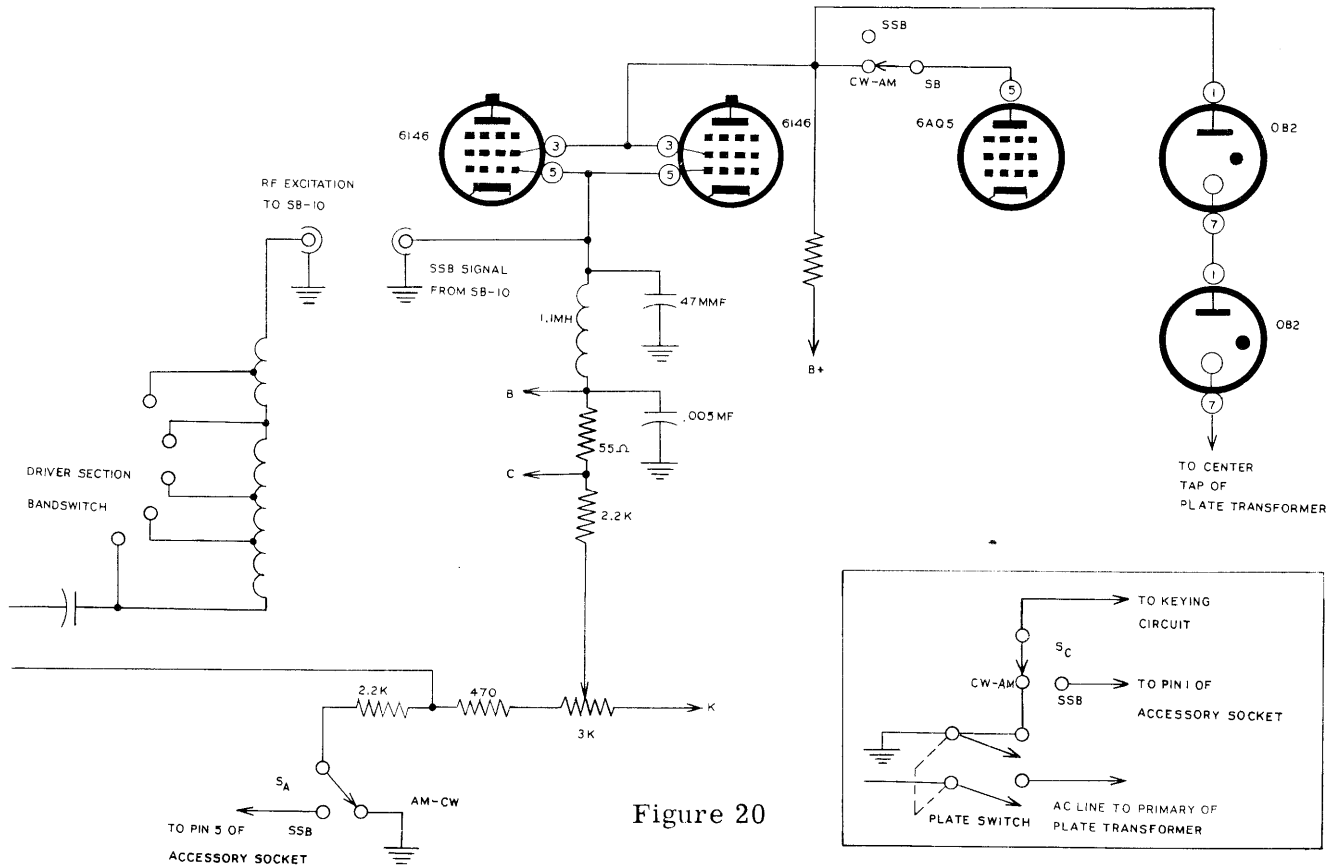

Figure 20

Referring to the schematic diagram in Figure 20, these changes are self-evident. A DPDT toggle switch mounted on the right hand side of the front panel above the chassis performs two functions. One switch section switches the clamp tube in and the VR tubes out of the circuit for Class C operation and the clamp tube out and the VR tubes into the circuit for Class AB1 operation. The 6146 screendropping resistor becomes the VR tube load resistor in linear operation. While the regulator tubes are not physically disconnected from the 6146 screen during Class C operation, they will not conduct since the Class C screen voltage is below the firing voltage of the tubes. The second switch section grounds the end of the fixed bias resistor string in the normal manner for CW or AM operation (Class C) but allows this function to be performed remotely in the SB-10 during SSB operation (Class AB1) by routing the lead through pin 5 of the accessory socket. A 3 KΩ control replaces the 2.2 KΩ resistor (between DD1 and EE1 in the DX-100 or DX-100B manual) in the bias string to provide a means of varying the fixed bias to the proper value for Class AB1 operation. Once set, this control needs no further adjustment since the rest of the bias required for Class C operation is developed by grid current flowing through the grid resistor.

Power for the adapter is brought out through the accessory socket. Filament voltage should be brought out through pin 7 and B+ through pin 6. The two blue 500Ω audio leads on terminal strip GG, already connected to pins 6 and 7, can be connected to suitable points to make this modification. The ratings of the DX-100 and DX-100B transformers are conservative enough to allow this extra load. If extended operation on SSB is contemplated, it is suggested that the modulator and speech amplifier tubes (1625, 12BY7, 12AX7) be removed to reduce the filament current drain. The SB-10 requires 300-350 VDC at 85 ma and 6.3 VAC at 3.5 A.

It is suggested that the drive be taken from the feedthrough insulator (point X in the DX-100 or DX-100B Manual) through a length of RG-62/U coaxial cable to a connector mounted on the rear apron of the chassis in the high voltage power supply compartment. Drill a hole in the intervening partition to allow passage of the cable. Disconnect the lead from the final amplifier grid circuit side of the feedthrough insulator to the terminal strip, thus breaking the RF path at this point. Mount a second coax connector on the rear apron of the transmitter directly behind the rearmost 6146 tube socket. Connect the center pin of this connector directly to the grid buss with #16 bare wire. This modification will require a jumper of RG-62/U coax between these added connectors for AM and CW operation in order to restore the normal RF path. RG-62/U cable is recommended in this application to minimize loss of drive at the higher frequencies.

The switch can be mounted on the front panel in the area beneath the "Heathkit" nameplate. The VR tubes and bias control can be mounted on a small aluminum bracket which can be secured under one of the power transformer mounting screw nuts near the LV filter choke. After replacing the 2.2 K $\Omega$  1 watt bias string resistor (between terminal strip DD-1 and EE-1) with a 3 K $\Omega$  control, reconnecting the end of the 2.2 K $\Omega$  1/2 watt resistor (connected to DD-1) to the control center lug, and running an extension of the ground end of the bias string (previously connected to DD-2) to the switch, the wiring is straightforward.

If the DX-100 or DX-100B, intended for use as a companion unit with the SB-10, has been previously modified to employ grid block keying of the buffer (12BY7) stage, the fact that the VFO is on at all times may cause objectionable interference during standby periods. If SSB and AM are the modes of operation most frequently employed, a return to the original cathode keying circuit is recommended. To retain the grid block method of keying but render the VFO inoperative during SSB standby periods, a suggested solution is shown in dotted lines on the schematic. By using a 3PDT switch of the rotary or lever type in place of the DPDT mentioned previously, the extra switch section can be employed to route the VFO and buffer cathode return to pin 1 of the accessory socket directly for external grounding during transmitting periods only, thus bypassing the plate switch, which is on continuously during SSB operation. A variation of this solution to the problem would be to accomplish switching of the plate transformer primary power externally by placing an external SPST switch across pins 3 and 4 of the accessory socket. Then, leaving the plate switch on the front panel in the OFF position, the cathode return lead appearing on pin 1 of the accessory socket can be grounded externally during transmitting periods. The external plate power switch can be mounted at any convenient location on the operating desk. To accomplish external grounding of the cathode return lead, refer to "Operation" on page 56.

Once the modification is complete, check your wiring once again. Connect a temporary jumper between pin 5 and pin 8 of the accessory socket. Now with the SB-10 disconnected from the transmitter, turn the power on. Place the "CW-Phone" switch in "CW" position and turn the drive control full CCW. After warmup, with the switch in Class AB1 position and no jumper between the adapter coaxial connections, apply plate voltage watching the plate current closely. Quickly adjust the fixed bias control until 55 ma of plate current is indicated. If the plate current is excessive or cannot be brought to this value, turn off the plate power and check your work once again. Once 55 ma of plate current is indicated, check to make sure the two OB2 voltage regulators are showing a soft blue glow. If a VOM or VTVM is available, the grid buss should show approximately -50 volts DC and the screens of the 6146's (pin 3) should show 210 VDC. Now turn the plate power off, place the switch in Class C position, and connect the short coaxial jumper between the adapter coax fittings on the back of the transmitter. Using a dummy load, check for normal AM or CW operation. A slight decrease in available grid drive can be attributed to the length of coax added to the RF signal path.

Once the modification is complete and the above tests are made, connect the SB-10 to the transmitter as described previously. If required, as outlined above, provide a ground-when-transmitting connection for the VFO and buffer cathode return. Now proceed with testing and adjustment of the SB-10 Adapter.

## TESTING AND ADJUSTMENT

- ( ) Connect the SB-10 to the companion transmitter as described in the preceding section. During the following test procedure and all subsequent operation on SSB, make sure the transmitter is in its SSB operating mode and both transmitter and adapter band switches are set on the same band.
- ( ) With the transmitter set for SSB operation, both power and plate switches on the transmitter in the OFF position, and the transmitter drive control full CCW, select the 80M band position on both the transmitter and adapter and set the SB-10 controls as follows:

Sideband selector .....	either UPPER or LOWER
Carrier Null A .....	full CCW
Carrier Null B .....	full CW
Audio Gain .....	full CCW
Function switch .....	STANDBY
Balanced modulator .....	5
Output .....	5
Transmitter sensitivity .....	full CCW (on rear apron)
Receiver sensitivity .....	full CCW (on rear apron)
* Audio balance .....	50% rotation from full CCW
** Phase balance .....	25% rotation from full CCW

\*This is the screwdriver adjustment on the audio and phasing deck nearest the left edge of the chassis.

\*\*This is the screwdriver adjustment on the audio and phasing deck nearest the center of the chassis.

- ( ) Place the power switch on the transmitter in the ON position. Check for any signs of overheating in the SB-10 and make sure all the tubes are lighted. Leave the transmitter plate switch in the OFF position.
- ( ) If no abnormal operation is noted in the preceding step, turn the SB-10 function switch to "MANUAL". The relay should close and the "Relative Power Output" meter may read slightly upscale. Once again, check for any signs of overheating or excessive plate dissipation in any tube, as indicated by the plate showing a red glow. If any signs of abnormal operation are apparent, return the function switch to STANDBY and recheck your work.
- ( ) Rotate the drive control on the transmitter about one-quarter turn from the extreme CCW position and tune the transmitter driver output circuits for maximum SB-10 meter indication.
- ( ) Tune the balance modulator control on the adapter for maximum meter reading and then tune the output control for maximum meter reading. Finally, adjust the slug in coil L1 on the RF sub-chassis for maximum SB-10 meter reading. Once L1 is so adjusted, it will need no further adjustment.
- ( ) Notice that, as the transmitter drive control is advanced in a CW direction, a point is reached where increased drive does not produce an increase in SB-10 meter reading. In all cases, the transmitter drive should be set just below this point for proper operation. After making all the preceding adjustments, the SB-10 meter should be reading in the upper third of the scale.
- ( ) Return the SB-10 function switch to STANDBY. Now place both the transmitter and adapter band switches in the 40M position and repeat the three preceding steps, this time finally adjusting the slug in coil L2 on the RF sub-chassis for maximum meter reading. Using the same procedure, adjust L3 for maximum indication on 20M, L4 for maximum indication on 15M, and L5 for maximum indication on 10M. The maximum indication on 10M may be less than for the lower bands but this is normal.

- (✓) Return the transmitter and adapter to 80M and, with the function switch in manual position, tune up once again. Now adjust carrier null A and carrier null B simultaneously for a minimum meter reading. The two controls will interact and it should be possible to null the carrier to a point where there is no meter reading. Once a null is obtained, both carrier null controls should be approximately in mid-position.
- ( ) Connect a hi-impedance microphone (crystal or dynamic) to the microphone input connector. Place the transmitter meter switch in the final amplifier grid current position. While speaking into the microphone, advance the audio gain control from its full CCW position. At approximately 25% rotation of the gain control, the SB-10 meter should hit a maximum reading on voice peaks that is about one-third the maximum reading before the carrier was suppressed. At the same time, the transmitter meter should begin to show slight vertical upward kicks in final grid current in the order of a fraction of a milliampere. Do not advance the audio gain control beyond this point.
- ( ) Place the function switch in the VOX position without changing any other setting. While speaking into the microphone, advance the transmitter sensitivity control on the rear apron of the SB-10 from its full CCW position until your normal operating voice produces positive relay operation. The setting of this control will vary slightly for different microphones and voices. The relay should open upon any hesitation in speech, indicating proper VOX operation.
- (✓) Return the function switch to STANDBY position and, noting its present position for future reference, turn the audio gain full CCW. Place the function switch in MANUAL position and re-insert some carrier by rotating one carrier null control (either A or B) until about one-half of the maximum unsuppressed carrier SB-10 meter reading is obtained.
- ( ) Make sure a dummy load (incandescent lamp of suitable wattage) is connected to the RF output of the transmitter. Place the transmitter meter switch in the final plate current position and the loading control at its minimum position. Place the transmitter plate switch in the ON position and tune the final amplifier for minimum plate current. Insert maximum carrier by further rotating the carrier null control previously used for partial carrier insertion to its extreme position. Now load the final amplifier to 250 ma using normal loading procedure. Load the final quickly to avoid damage to the tubes due to excessive plate dissipation.
- ( ) Leave the transmitter plate switch in the ON position and null the carrier once again by returning the carrier null control used for carrier re-insertion to the minimum SB-10 meter reading position. The dummy load lamp should be dark with the carrier suppressed and the final amplifier plate current should be at its 50 ma resting value.
- ( ) Place the function switch in VOX position without changing any other control settings. Advance the audio gain control to the point previously noted and speak into the microphone. The dummy load lamp brilliance, final amplifier plate current, and SB-10 meter reading will peak together on voice peaks. Check the final amplifier grid current; the meter should kick up very slightly on extreme voice peaks. On voice, the meter reading final amplifier plate current cannot respond fast enough to read actual current peaks. Therefore, while the final amplifier is loaded to 250 ma, the peak reading under modulation should be only 100 to 125 ma to prevent "flat-topping".
- ( ) With the function switch in VOX position, check to see if the final amplifier plate current and driver plate current go to zero when standing by and the relay opens. This indicates proper connections in the VOX relay circuit.
- ( ) Turn the transmitter plate switch OFF and return the SB-10 function switch to STANDBY and the audio gain full CCW.

NOTE: An audio generator capable of producing a clean 1000 cps sine wave will be required to perform the following steps. An oscilloscope is also desirable but will not be necessary if a good selectable sideband SSB receiver is available. If these items are not part of the builders ham shack test equipment, they can usually be borrowed from another ham or a radio-TV service shop. For the amateur contemplating extensive SSB operation, the purchase of these two items will prove a wise investment. These items will also find numerous other uses around the ham shack. A complete line of suitable test equipment is offered in kit form by the Heath Company.

- ( ) Connect the output of the audio generator to the microphone input on the SB-10. Set the frequency to 1000 cps and adjust the output voltage to approximately 30 millivolts. If output voltage control or calibration is not provided, use a 500 K $\Omega$  control to divide the output voltage down to a level low enough to insure that the speech-amplifier is not being over-driven.
- ( ) Connect the vertical input of the oscilloscope, if available, across the transmitter dummy load. A direct connection may be used since, due to the low output impedance, the voltages developed will not be excessive. If additional vertical attenuation is required, use a 50-100 mmf coupling capacitor.
- ( ) Tune up the transmitter and adapter on 80M and load the transmitter final to 250 ma.
- ( ) If an oscilloscope is not available, or as an additional indicator of unwanted suppression, insert some carrier and tune an SSB receiver to zero-beat the carrier. Now null the carrier. If excessive radiation from the exciter stages of the transmitter, which is operating on the fundamental frequency, tends to block or overload the receiver, physically separate the receiver from the transmitter until the feedthrough is minimized. Shorting the receiver antenna input terminals may help.

NOTE: When using the single tone test as described in the following steps, keep the intervals of test "on time" to a minimum to avoid exceeding the average plate dissipation of the 6146 final amplifier tubes.

- ( ) Now advance the audio gain control until about 125 ma of final amplifier plate current is indicated. Adjust the vertical gain of the oscilloscope for full scope face height. If an SSB receiver is being used, select the unwanted sideband on the receiver.
- ( ) Now adjust the phase balance and audio balance control for minimum ripple on the scope pattern or for minimum S-meter reading, if an SSB receiver is being used. This method of adjustment is based on the principle that for a single audio tone input, the RF output consists of a single RF signal, the desired sideband. On an oscilloscope, this RF signal looks like a CW signal, that is, a smooth strip.
- ( ) During the adjustment of the phase balance and audio balance control, note that the spacing of the ripple peaks due to carrier is twice that of those due to unwanted sideband. Thus, it is possible to tell what kind of adjustment is needed. The carrier null controls affect carrier suppression and the audio and ratio balance controls affect unwanted sideband suppression.
- ( ) Once maximum suppression has been obtained for one sideband, select the other sideband on the SB-10. The suppression on this sideband will probably not be as good as on the other sideband. Readjust the balance controls until a compromise is reached where the suppression of either sideband is equally good. This is important even though operation on one particular sideband is never intended.
- ( ) Refer to the table in Figure 21 on page 56. If an oscilloscope is being used, reference to this table will give a good approximation of the amount of unwanted sideband suppression obtained. When adjusted and operating properly, the SB-10 will exhibit about 30 db unwanted suppression on either sideband. The suppression obtained during this procedure on 80M will hold for all other bands and no further adjustment is required.
- ( ) To demonstrate the relationship of actual RF peaks to indicated plate current peaks, disconnect the audio generator from the microphone input and reconnect the microphone. While speaking into the microphone, adjust the audio gain to the point where about 125 ma peaks are indicated on the meter. Notice that the RF peaks on the scope are just beginning to "flat-top". These RF peaks correspond to actual plate current peaks of about 250 ma but the meter cannot follow fast enough. Thus, the maximum indicated plate current peaks are much lower.
- ( ) Turn the transmitter plate power OFF and place the SB-10 function switch in STANDBY. Disconnect the oscilloscope from the dummy load and the audio generator from the microphone input. Connect the microphone to the microphone input.

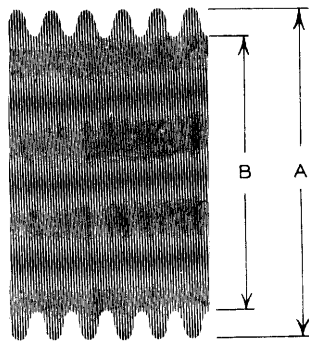

$$\frac{\text{WANTED}}{\text{UNWANTED}} \text{ (RATIO IN DB)} = 20 \text{ LOG } \frac{A+B}{(A-B)}$$

SUPPRESSION IN DB	$\frac{A+B}{(A-B)}$
20	10
25	18
30	32
35	56
40	100

Figure 21

- ( ) Connect the audio output of the receiver to terminals 1 and 2 on the rear of the SB-10 and the receiver speaker to terminals 2 and 3. Make sure that if one side of the receiver audio output is grounded, that this lead is connected to terminal 2 on the SB-10.
  - ( ) Tune in a fairly strong signal on the receiver and adjust the receiver gain for normal operating volume.
  - ( ) Place the SB-10 function switch in VOX position. Do not turn on the transmitter plate power. With the transmitter sensitivity control in the same position as previously set, hold the microphone about 3 feet in front of the receiver speaker or close enough to start the VOX circuit cycling. Now advance the receiver sensitivity until the cycling ceases. This adjusts the anti-trip action for normal operation. Recheck for normal voice operation and readjust the transmitter sensitivity, if necessary.
  - ( ) Turn off all power and disconnect all cables and wires from the adapter.
  - ( ) Place the plastic control guards on the phase and balance controls.
  - ( ) Insert the four small rubber feet in the four holes in the bottom of the cabinet.
  - ( ) Place the adapter in the cabinet and secure with two #6 sheet metal screws through the back panel into the two corresponding holes in the rear apron of the chassis.
  - ( ) Place the adhesive label on the back of the cabinet above the opening for the rear chassis apron.
- This completes testing and adjustment of the SB-10 SSB Adapter.



### OPERATION

For on-the-air operation, the SB-10 connections are the same as described under Testing and Adjustment. Tuning and operating the transmitter and adapter is accomplished in the same manner as used during initial testing. Only one word of caution to the newcomer to SSB: Use audio gain sparingly to prevent splatter due to flat-topping.

In general, lower sideband (LSB) is used by most amateurs on the 80 and 40 meter bands while the upper sideband (USB) is used on 20, 15 and 10 meters. The "AM" position on the SB-10 mode switch produces a double sideband signal. Carrier may be inserted in any mode (USB and carrier, LSB and carrier, or DSB and carrier) by merely rotating either carrier null control from the balanced position. The resulting signals are all AM with the latter (DSB and carrier) being similar to a normal high level amplitude modulated carrier. However, when inserting carrier, be sure not to exceed the average plate dissipation of the final amplifier tubes. Thus, if carrier is inserted, the final amplifier should only be loaded to 100 watts input (125 ma). If considerable AM operation is at times desired, then a simple return to the normal high level capability of the companion transmitter is the logical choice, for the obvious reasons of increased efficiency and effectiveness.

The terminal strip on the rear of the SB-10 provides a capability for antenna relay operation, exciter keying, and receiver speaker muting as indicated on the rear apron label. Receiver speaker muting during SSB operation is generally preferred to placing the receiver in STANDBY. With modern coaxial relays and electronic TR switches, adequate protection against damage to the receiver RF stages due to overloading is afforded.



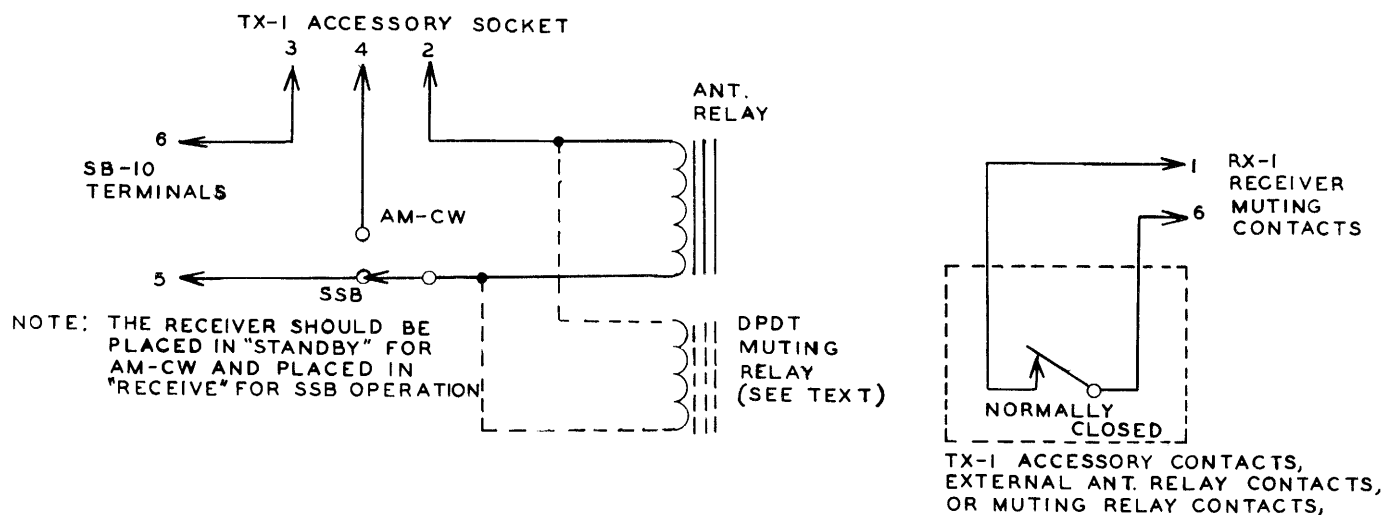

Figure 22

A suitable control circuit is shown in Figure 22 for switching of antenna relay and muting circuits between SSB and AM-CW. The receiver front panel muting switch is placed in STANDBY during AM-CW operation and in RECEIVE for SSB operation. Thus, full standby is used for AM-CW muting but speaker muting is employed for SSB duplex operation. An electronic TR switch may be used in place of the antenna relay, of course, but the circuitry illustrated may still be required to operate a muting relay in some installations. The necessity for the muting relay will depend upon whether or not an electronic TR switch is used, whether or not the coaxial relay has sufficient external contacts, and whether or not a "ground-when-transmit" connection must be provided, due to the grid block keying modification of either a DX-100 or DX-100B transmitter. If a TX-1 is used as the companion transmitter, no muting relay will be required, regardless of the type of antenna switching device employed.

Two methods may be employed to get on frequency before actually placing the transmitter on the air. The transmitter plate power must be left off during these procedures to avoid disturbing the "round-table" QSO so often encountered in SSB operation until the transmitter is on frequency and ready for break-in. One method merely involves properly tuning in the incoming SSB signal on the receiver and then "zero-beating" by merely pulling the plug from the key jack, or on the TX-1, depressing the SPOTTING pushbutton. Once the frequency is set, check to make sure the proper sideband (that of the incoming signal) is selected on the SB-10 and the transmitter is ready for break-in.

A second method involves, once again, properly tuning in the incoming signal on the receiver, selecting the proper sideband on the SB-10, and then talking yourself on frequency. This can be done by plugging a set of headphones into the receiver, placing the SB-10 function switch in manual position, and tuning the transmitter VFO for normal voice in the receiver.

Once the SB-10 is set up in the shack in operating position, it may be necessary to readjust either the transmitter sensitivity or receiver sensitivity controls, due to the change in position with regard to the receiver or due to acoustic differences. These controls can be readjusted in accordance with the procedure described under TESTING AND ADJUSTMENT to suit operating conditions.

If it is desired to increase or decrease the time required for the relay to open after the cessation of speech during VOX operation, the 2.2 megohm resistor between F7 and FF2 can be replaced with a different value. Increasing the resistance increases the time delay and decreasing the resistance decreases the time delay.

While the SB-10 was designed primarily for use with the Heathkit Models DX-100, DX-100B, and TX-1 as a complete SSB transmission capability, it can be used to excite higher power linear amplifiers by itself or in conjunction with the companion transmitter. Any grounded cathode linear amplifier requiring 10 watts PEP or less drive can be driven directly by the SB-10 and any grounded grid linear amplifier may be driven to full output with the SB-10 and TX-1 combination. When driving a linear amplifier directly with the SB-10, a companion transmitter must still be used to supply power and RF excitation at the fundamental frequency. However, under these conditions, a much lower power AM-CW transmitter may be used since the final amplifier of the companion transmitter would not be utilized. Care must be taken to observe the limitation of plate and filament power that such a transmitter would be capable of supplying to the SB-10. The use of a separate power supply for the SB-10, would be advisable under a condition such as this.

#### IN CASE OF DIFFICULTY

Mistakes in wiring are the most common cause of difficulty. Consequently, the first step is to recheck all wiring against the pictorials and schematic diagrams. Often having a friend check the wiring will locate an error consistently overlooked.

With miniature sockets, there is a possibility of shorts between adjacent socket terminals due to the close spacing. This should be checked and if any doubt exists, the terminals should be pried apart until obvious spacing can be seen between them.

Sometimes apparently good solder connections will have an insulating coating of rosin between the wire, the terminal, and the solder. This is often the case when insufficient heat was applied in soldering. An ohmmeter check of any questionable connections will test for this condition. All voltages should be "off" for such tests.

If the fuses in the transmitter blow consistently when the function switch is placed either in MANUAL or VOX, check the resistance to ground at pin 6 of the power plug with all power off and the function switch in MANUAL. A reading of about 40 K $\Omega$  should be obtained. A shorted filament lead will be revealed immediately by burning insulation on the affected lead plus failure of the tubes affected to light.

If some difficulty persists after the steps outlined have been completed, attempt to localize the trouble to a particular stage in the adapter circuit. Be sure to re-read the circuit description on pages 7 and 8 so that "cause and effect" reasoning may be employed as the search for trouble progresses. Use the tuning procedure and the voltage chart on page 59 as a basis for localization and refer to the block diagram and schematic to visualize circuit relationships. The panel tuning meter will also aid in locating trouble.

If no SB-10 meter reading can be obtained under any condition, check the connecting coaxial cables for possible shorts plus the internal coaxial cable runs. Check the bandswitch wiring on all stages for errors or short circuits. Measure the voltages on the 6CL6 and 6BQ5 tubes to insure proper operation of these stages. Inspect the RF input connections on the balanced modulator sub-chassis.

Checking the RF input connections, RF phase shift networks, and balanced modulator voltages may require removal of the front panel and chassis apron. To remove same, remove the microphone connector and unsolder the center conductor, remove both the audio gain control and function switch, and remove all the front panel knobs. Now remove the four #6 sheet metal screws holding the front apron to the chassis and slide the panel and apron off the control shafts. Operation for test purposes with the front panel removed, is possible by providing a ground return to the chassis for the function switch and reconnecting the inner conductor of the microphone input cable to the connector.

### VOLTAGE CHART

AREA	TUBE	PIN 1	PIN 2	PIN 3	PIN 4	PIN 5	PIN 6	PIN 7	PIN 8	PIN 9
BAL. MOD. DECK	"A" 12AT7	300	0	3.2	0	0	300	0	3.2	6.3 VAC
	"B" 12AT7	300	0	3.2	0	0	300	0	3.2	6.3 VAC
RF DECK	"A" 6CL6	5.5	0	250	6.3 VAC	0	300	0	250	0
	"B" 6BQ5	NC	0	7.8	6.3 VAC	0	NC	300	NC	250
AUDIO AND PHASING DECK	"A" 12AX7	160	0	1	0	0	160	0	1	6.3 VAC
	"B" 6AL5	0 to 0.1	-0.7	6.3 VAC	0	0 to 0.1	0	-0.7	0	0
	"C" 12AT7	135	0	1.7	0	0	135	0	1.7	6.3 VAC
	"D" 12AT7	300	0	3.2	0	0	300	0	3.2	6.3 VAC
	"F" 12AT7	300	0	3.6	0	0	270	0 to 0.1	2.7 *12.5	6.3 VAC

Condition, unless otherwise specified, are as follows:

Input and output coaxial cables disconnected.  
 Function switch in "Manual".  
 Carrier null controls at mid-position.  
 All other controls full CCW.

Measurements taken with a Heathkit Model V-7A VTVM between pin and ground.

\*With the function switch in "VOX".

NOTE: With the function switch in "VOX", all voltages on tubes on the Bal. Mod. and RF Decks will be zero with the exception of filament voltages.

Inspection of the RF phase shift networks and balanced modulator voltages may be called for if either the carrier or unwanted sideband suppression cannot be obtained. If the carrier is not suppressed with both carrier null controls in the middle third of their range, balanced modulator trouble should be assumed. Check for a bad 12AT7 in the balanced modulator, improper voltages, or wiring error. If unwanted sideband suppression cannot be obtained, check the RF phase shift network connections, especially the stacking and connection of the precision mica capacitors.

If unwanted sideband suppression is poor after the above checks, measure the two AC voltages at pins D1 and D6, with steady 1000 cps under signal input. They should be equal or it should be possible to make them equal by adjusting the audio balance control. When the two voltages are

equal, the audio balance control arm should be in the middle third of its range or a bad 12AT7, or wiring error, is indicated.

Another source of possible difficulty in obtaining unwanted sideband suppression is the audio phase shift network. The AC voltages at pins 5-1 and 3-7 of the audio phase shift network socket E should be in the ratio of 2 to 7 for a steady 1000 cps audio signal input. The lower voltage will appear on pins 3-7 and the ratio should be adjustable by rotation of the phase balance control. A more precise check for proper phase shift would be to feed the signal from D2 to the horizontal input and the signal from D7 to the vertical input of an oscilloscope and adjusting both vertical and horizontal oscilloscope gains for equal deflection. Adjusting the phase balance control, a perfect circle pattern on the scope should be obtained indicating exact 90° audio phase shift, providing the phase shifts in the horizontal and vertical oscilloscope circuits are equal.

The interstage and modulation transformers can be easily checked as a possible source of difficulty by measuring the DC resistance of the windings. The DC resistance of the primary of T4 is 650 Ω and the secondary is 40 Ω. Both T3 and T1 exhibit a primary DC resistance of 625 Ω and a secondary DC resistance of 850 Ω.

If no audio signal can apparently be passed through the audio stages, use a VTVM, signal tracer, or headset (capacitively coupled for safety) to apply normal audio trouble-shooting techniques. The audio circuitry is straight forward.

If the actual generated sideband is opposite to that indicated on the panel, after proper operation is obtained, reverse the transformer leads to lugs 7 and 8 of the sideband selector switch, RS.

Poor linearity in any adapter stage will be indicated by flattening or distorting of the transmitter RF output wave form obtained on an oscilloscope with the selector switch in AM position and a 1000 cps audio input. (This is the familiar "Two-Tone" test.) No indication of non-linearity should be apparent before rated output is obtained. Check the operating voltages, especially bias voltages, on all stages against the voltage chart. Also check the operating voltages on the final amplifier of the companion transmitter per the modification instructions given on page 50. Adjusting the loading of the final amplifier will also affect linearity and should be checked.

If the VOX and/or the anti-trip circuits appear to be inoperative, check the negative voltages produced at pin 2 of the 6AL5 socket B as follows: Turn the receiver sensitivity full CCW and the transmitter sensitivity full CW, and speak into the microphone. Note the maximum peak negative voltage which should be approximately -40 volts, depending on the microphone output voltage. Turn the transmitter sensitivity full CCW and the receiver sensitivity full CW. Connect the audio output of a receiver to terminals 1 and 2 on the rear of the SB-10 and adjust the gain for normal listening volume. Note the maximum peak negative voltage at B2, which should be approximately -90 volts, depending on the receiver volume. If either of these voltages is low or not present, check the corresponding triode amplifier connections and the 6AL5 connections. Also check for a bad tube at either of these locations. If the relay action is erratic, check the voltages at F8 against the voltage chart for the conditions listed. If the voltage is improper, check for an error in function switch wiring, a short in the voltage divider network, or a bad resistor.

## SERVICE

If, after applying the information contained in this manual and your best efforts, you are still unable to obtain proper performance, it is suggested that you take advantage of the technical facilities which the Heath Company makes available to its customers.

The Technical Consultation Department is maintained for your benefit. This service is available to you at no charge. Its primary purpose is to provide assistance for those who encounter difficulty in the construction, operation or maintenance of HEATHKIT equipment. It is not intended, and is not equipped to function as a general source of technical information involving kit modifications nor anything other than the normal and specified performance of HEATHKIT equipment.

Although the Technical Consultants are familiar with all details of this kit, the effectiveness of their advice will depend entirely upon the amount and the accuracy of the information furnished by you. In a sense, YOU MUST QUALIFY for GOOD technical advice by helping the consultants to help you. Please use this outline:

1. Before writing, fully investigate each of the hints and suggestions listed in this manual under "IN CASE OF DIFFICULTY." Possibly it will not be necessary to write.
2. When writing, clearly describe the nature of the trouble and mention all associated equipment. Specifically report operating procedures, switch positions, connections to other units and anything else that might help to isolate the cause of trouble.
3. Report fully on the results obtained when testing the unit initially and when following the suggestions under "IN CASE OF DIFFICULTY." Be as specific as possible and include voltage readings if test equipment is available.
4. Identify the kit model number and date of purchase, if available.
5. Print or type your name and address, preferably in two places on the letter.

With the above information, the consultant will know exactly what kit you have, what you would

like it to do for you and the difficulty you wish to correct. The date of purchase tells him whether or not engineering changes have been made since it was shipped to you. He will know what you have done in an effort to locate the cause of trouble and, thereby, avoid repetitious suggestions. He will make no incorrect assumptions nor waste time checking files for the correct spelling of name and address.

(The automatic letter opener sometimes cuts through the letter, hence the suggestion to print the name and address twice.) In short, he will devote full time to the problem at hand, and through his familiarity with the kit, plus your accurate report, he will be able to give you a complete and helpful answer. If replacement parts are required, they will be shipped to you, subject to the terms of the Warranty.

The Factory Service facilities are also available to you, in case you are not familiar enough with electronics to provide our consultants with sufficient information on which to base a diagnosis of your difficulty, or in the event that you prefer to have the difficulty corrected in this manner. You may return the completed instrument (including all connecting cables) to the Heath Company for inspection and necessary repairs and adjustments. You will be charged a fixed fee of \$14.00, plus the price of any additional parts or material required. However, if the completed kit is returned within the Warranty period, parts charges will be governed by the terms of the Warranty. State the date of purchase, if possible.

Local Service by Authorized HEATHKIT Service Centers is also available in some areas and often will be your fastest, most efficient method of obtaining service for your HEATHKIT equipment. Although you may find charges for local service somewhat higher than those listed in HEATHKIT manuals (for factory service), the amount of increase is usually offset by the transportation charge you would pay if you elected to return your kit to the Heath Company.

HEATHKIT Service Centers will honor the regular 90 day HEATHKIT Parts Warranty on all kits, whether purchased through a dealer or directly from Heath Company; however, it will be necessary that you verify the purchase date of your kit.

Under the conditions specified in the Warranty, replacement parts are supplied without charge; however, if the Service Center assists you in locating a defective part (or parts) in your kit, or installs a replacement part for you, you may be charged for this service.

HEATHKIT equipment purchased locally and returned to Heath Company for service must be accompanied by your copy of the dated sales receipt from your authorized HEATHKIT dealer in order to be eligible for parts replacement under the terms of the Warranty.

**THIS SERVICE POLICY APPLIES ONLY TO COMPLETED EQUIPMENT CONSTRUCTED IN ACCORDANCE WITH THE INSTRUCTIONS AS STATED IN THE MANUAL.** Equipment that has been modified in design will not be accepted

for repair. If there is evidence of acid core solder or paste fluxes, the equipment will be returned NOT repaired.

For information regarding modification of HEATHKIT equipment for special applications, it is suggested that you refer to any one or more of the many publications that are available on all phases of electronics. They can be obtained at or through your local library, as well as at most electronic equipment stores. Although the Heath Company sincerely welcomes all comments and suggestions, it would be impossible to design, test, evaluate and assume responsibility for proposed circuit changes for special purposes. Therefore, such modifications must be made at the discretion of the kit builder, using information available from sources other than the Heath Company.

#### REPLACEMENTS

Material supplied with HEATHKIT products has been carefully selected to meet design requirements and ordinarily will fulfill its function without difficulty. Occasionally improper instrument operation can be traced to a faulty component. Should inspection reveal the necessity for replacement, write to the Heath Company and supply all of the following information.

- A. Thoroughly identify the part in question by using the part number and description found in the manual Parts List.
- B. Identify the type and model number of kit in which it is used.

C. Mention date of purchase.

D. Describe the nature of defect or reason for requesting replacement.

The Heath Company will promptly supply the necessary replacement. **PLEASE DO NOT RETURN THE ORIGINAL COMPONENT UNTIL SPECIFICALLY REQUESTED TO DO SO.** Do not dismantle the component in question as this will void the guarantee. This replacement policy does not cover the free replacement of parts that may have been broken or damaged through carelessness on the part of the kit builder.

## SHIPPING INSTRUCTIONS

In the event that your instrument must be returned for service, these instructions should be carefully followed.

ATTACH A TAG TO THE EQUIPMENT BEARING YOUR NAME, COMPLETE ADDRESS, DATE OF PURCHASE, AND A BRIEF DESCRIPTION OF THE DIFFICULTY ENCOUNTERED. Wrap the equipment in heavy paper, exercising care to prevent damage. Place the wrapped equipment in a stout carton of such size that at least three inches of shredded paper, excelsior, or other resilient packing material can be placed between all sides of the wrapped equipment and the carton. Close and seal the carton with gummed paper tape, or alternately, tie securely

with stout cord. Clearly print the address on the carton as follows:

To: HEATH COMPANY  
Benton Harbor, Michigan

Include your name and return address on the outside of the carton. Preferably affix one or more "Fragile" or "Handle With Care" labels to the carton, or otherwise so mark with a crayon of bright color. Ship by parcel post or prepaid express; note that a carrier cannot be held responsible for damage in transit if, in HIS OPINION, the article is inadequately packed for shipment.

### PARTS LIST

PART No.	PARTS Per Kit	DESCRIPTION	PART No.	PARTS Per Kit	DESCRIPTION
Resistors			Capacitors		
1-4	1	330 $\Omega$ 1/2 watt	20-11	4	100 mmf mica ✓
1-7	1	680 $\Omega$ 1/2 watt	20-31	1	68 mmf mica ✓
1-9	3	1 K $\Omega$ 1/2 watt	20-89	2	817 mmf 1% silver mica ✓
1-14	1	3.3 K $\Omega$ 1/2 watt	20-90	2	439 mmf 1% silver mica ✓
1-21	5	15 K $\Omega$ 1/2 watt	20-91	2	223 mmf 1% silver mica ✓
1-23	1	27 K $\Omega$ 1/2 watt	20-92	2	150 mmf 1% silver mica ✓
1-26	8	100 K $\Omega$ 1/2 watt	20-93	2	110 mmf 1% silver mica ✓
1-35	1	1 megohm 1/2 watt	21-9	1	100 mmf disc ceramic ✓
1-37	3	2.2 megohm 1/2 watt	21-14	5	.001 mfd disc ceramic ✓
1-41	1	10 $\Omega$ 1/2 watt	21-16	13	.01 mfd disc ceramic ✓
1-45	2	220 $\Omega$ 1/2 watt	21-27	2	.005 mfd disc ceramic ✓
1-86	1	5.6 megohm 1/2 watt	21-33	1	3.3 mmf disc ceramic ✓
1-9A	2	10 K $\Omega$ 1 watt	23-28	2	.1 mfd tubular ✓
1-11A	1	10 $\Omega$ 1 watt	25-16	1	20 mfd 350 V electrolytic ✓
1-18A	2	150 $\Omega$ 1 watt	25-35	1	2 mfd 50 V electrolytic ✓
1-23A	1	2.2 K $\Omega$ 1 watt	26-22	1	75 mmf variable ✓
1-13B	1	220 $\Omega$ 2 watt	26-46	1	50-50 mmf butterfly ✓
1-14B	2	1.5 K $\Omega$ 2 watt			
1-24B	1	100 K $\Omega$ 2 watt			
2-44A	2	50 $\Omega$ 1/2% precision			

PART No.	PARTS Per Kit	DESCRIPTION	PART No.	PARTS Per Kit	DESCRIPTION
<b>Coils-Chokes-Transformers</b>			<b>Hardware (Cont'd.)</b>		
40-122	1	Coil and two wafer assembly	252-7	16	3/8" control nut
40-123	1	80 meter driver coil	253-1	1	#6 fiber washer
40-124	1	40 meter driver coil	253-10	10	Control washer
40-125	1	20 meter driver coil	253-22	3	3/8" ID x 1/8" thick washer
40-126	1	15 meter driver coil	254-1	12	#6 lockwasher
40-127	1	10 meter driver coil	254-4	11	3/8" lockwasher
40-128	1	Coil and one wafer assembly	254-7	26	#3 lockwasher
45-3	2	1 mh RF choke	259-1	4	#6 solder lug
45-4	1	1.1 mh RF choke	259-2	2	#8 solder lug
45-14	1	2.5 mh RF choke	259-6	6	#6 (small) solder lug
45-19	1	Parasitic choke	259-10	6	3/8" control solder lug
45-30	4	500 $\mu$ h RF choke	259-11	2	Terminal spade lug
51-3	1	Anti-trip transformer	<b>Controls-Switches</b>		
51-37	1	Interstage transformer	10-15	2	500 K $\Omega$ control ✓
51-38	2	Modulation transformer	10-46	1	100 K $\Omega$ control ✓
<b>Socket-Terminal Strips-Knobs-Connectors</b>			11-22	2	500 $\Omega$ wire-wound control ✓
431-2	3	2-lug terminal strip-no gnd	63-53	1	3 position switch
431-3	1	3-lug terminal strip-no gnd	63-157	1	Sideband reversing switch
431-5	1	4-lug terminal strip-no gnd	63-158	1	Band switch
431-7	1	6-lug screw terminal strip	B11-33	2	1000 $\Omega$ control ✓
431-10	5	3-lug terminal strip - center gnd	<b>Meters-Tubes</b>		
431-14	3	2-lug terminal strip-rh gnd	407-54	1	Meter, 200 $\mu$ a ✓
431-16	1	2-lug terminal strip-lh gnd	411-24	5	12AT7 tube ✓
432-3	1	Microphone connector	411-26	1	12AX7 tube ✓
434-4	1	Octal socket (ring mount)	411-40	1	6AL5 tube ✓
434-34	1	7 pin miniature socket	411-63	1	6CL6 tube ✓
434-36	4	9 pin shielded miniature ceramic socket	411-108	1	EL84/6BQ5 tube ✓
434-39	1	Octal socket	<b>Sheet Metal Parts</b>		
434-43	2	9 pin shielded miniature socket	200-M142	1	Phasing and audio chassis
434-56	2	9 pin miniature socket	200-M143	1	Balanced modulator subchassis
436-5	2	Female coax connector	200-M144	1	RF subchassis
438-3	1	Phone plug	202-M17	1	Front chassis apron
438-6	2	Octal plug	202-M18	1	Rear chassis apron
438-9	4	Male coax connector	203-136F175	1	Front panel
462-30	2	Knob - 1/2" plastic	204-M147	2	Reinforcement brackets
462-60	5	Knob-aluminum 1 1/4" dia.	<b>Miscellaneous</b>		
462-61	3	Knob-aluminum 9/16" dia.	56-4	1	Diode
<b>Hardware</b>			69-6	1	5 pole D. T. telephone relay
250-8	20	#6 sheet metal screw	73-1	3	3/8" rubber grommet
250-9	1	6-32 x 3/8" RHMS	73-4	4	5/16" rubber grommet
250-16	2	8-32 x 1/8" setscrew	84-10	1	Audio phase shift network
250-31	18	6-32 x 1/4" RHMS	90-75	1	Cabinet
250-93	5	8-32 x 1/4" Allen head setscrew	100-110	1	Audio wire harness
250-49	26	3-48 x 1/4" BHMS	100-111	1	Function control wire harness
250-105	3	8-32 x 1/8" Allen head setscrew	205-M87	2	9 pin socket shield
252-1	26	3-48 nut	206-3	4	Tube shield
252-3	18	6-32 nut	206-54	1	9 pin 2 3/8" tube shield



<u>PART No.</u>	<u>PARTS Per Kit</u>	<u>DESCRIPTION</u>	<u>PART No.</u>	<u>PARTS Per Kit</u>	<u>DESCRIPTION</u>
Miscellaneous (Cont'd.)			Miscellaneous (Cont'd.)		
252-20	2	Plastic control guard	390-53	1	Adhesive label
261-4	4	Rubber feet	391-7	1	"Heathkit" nameplate
340-2	1	length #20 bare wire	435-1	1	Octal plug ring
340-3	1	length #16 bare wire	438-12	4	Coax adapter insert
343-2	1	length RG58A/U coax	440-1	2	Octal plug and socket cap
343-3	1	length shielded wire	453-18	1	1/4" x 6 11/16" shaft extension
344-1	1	length hookup wire	455-6	5	Panel bushing
346-1	1	length insulating sleeving	456-4	1	1/4" shaft coupling-insulated
346-2	1	length plastic sleeving	490-6	1	5/64" Allen wrench
347-9	1	length 3 wire shielded cable	595-201	1	Manual

### SPECIFICATION CHANGES

All prices are subject to change without notice. The Heath Company reserves the right to discontinue instruments and to change specifications at any time without incurring any obligation to incorporate new features in instruments previously sold.

## WARRANTY

Heath Company warrants that for a period of three months from the date of shipment, all Heathkit parts shall be free of defects in materials and workmanship under normal use and service and that in fulfillment of any breach of such warranty, Heath Company shall replace such defective parts upon the return of the same to its factory. The foregoing warranty shall apply only to the original buyer, and is and shall be in lieu of all other warranties, whether express or implied and of all other obligations or liabilities on the part of Heath Company and in no event shall Heath Company be liable for any anticipated profits, consequential damages, loss of time or other losses incurred by the buyer in connection with the purchase, assembly or operation of Heathkits or components thereof. No replacement shall be made of parts damaged by the buyer in the course of handling or assembling Heathkit equipment.

NOTE: The foregoing warranty is completely void and we will not replace, repair or service instruments or parts thereof in which acid core solder or paste fluxes have been used.

HEATH COMPANY

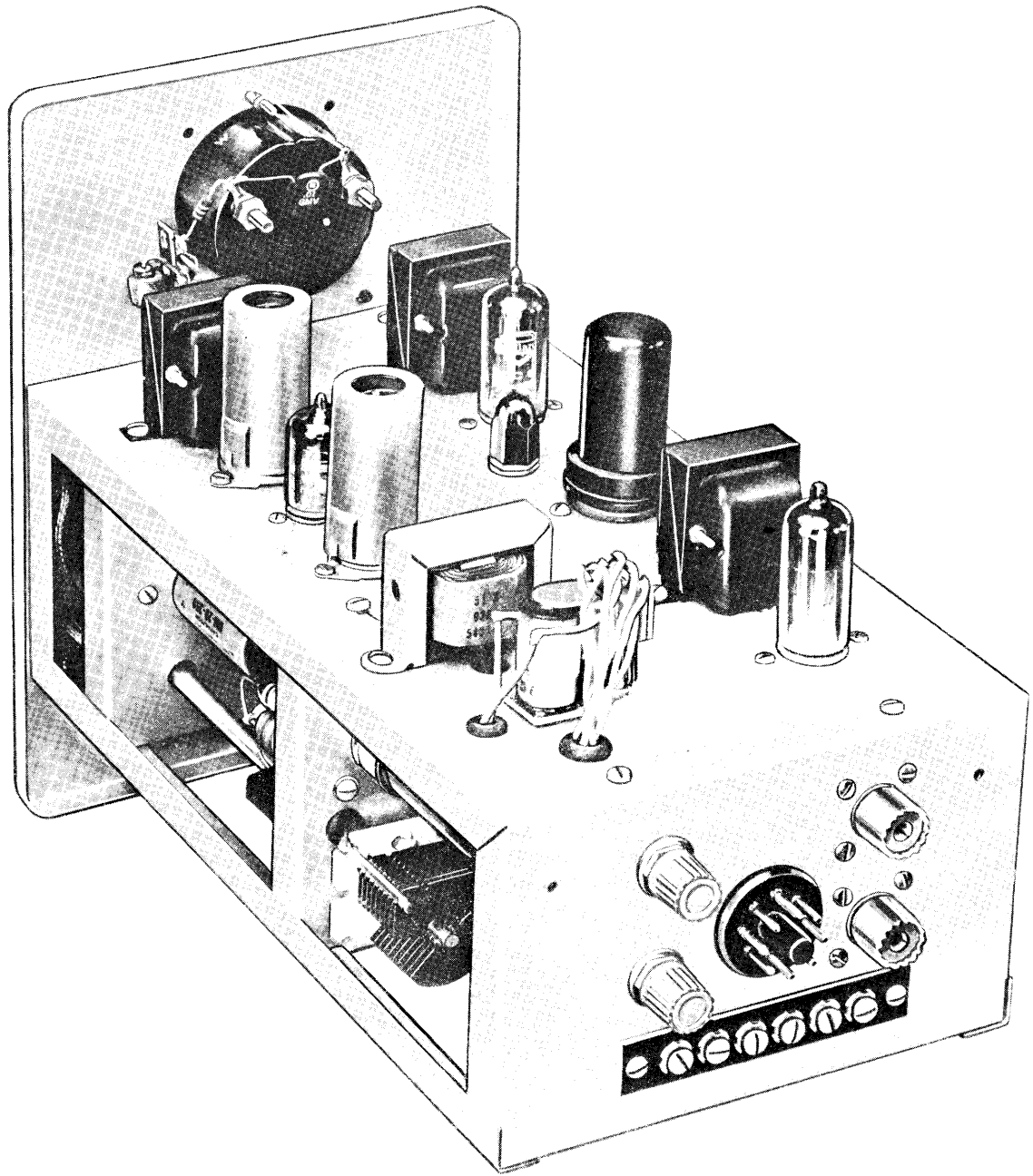

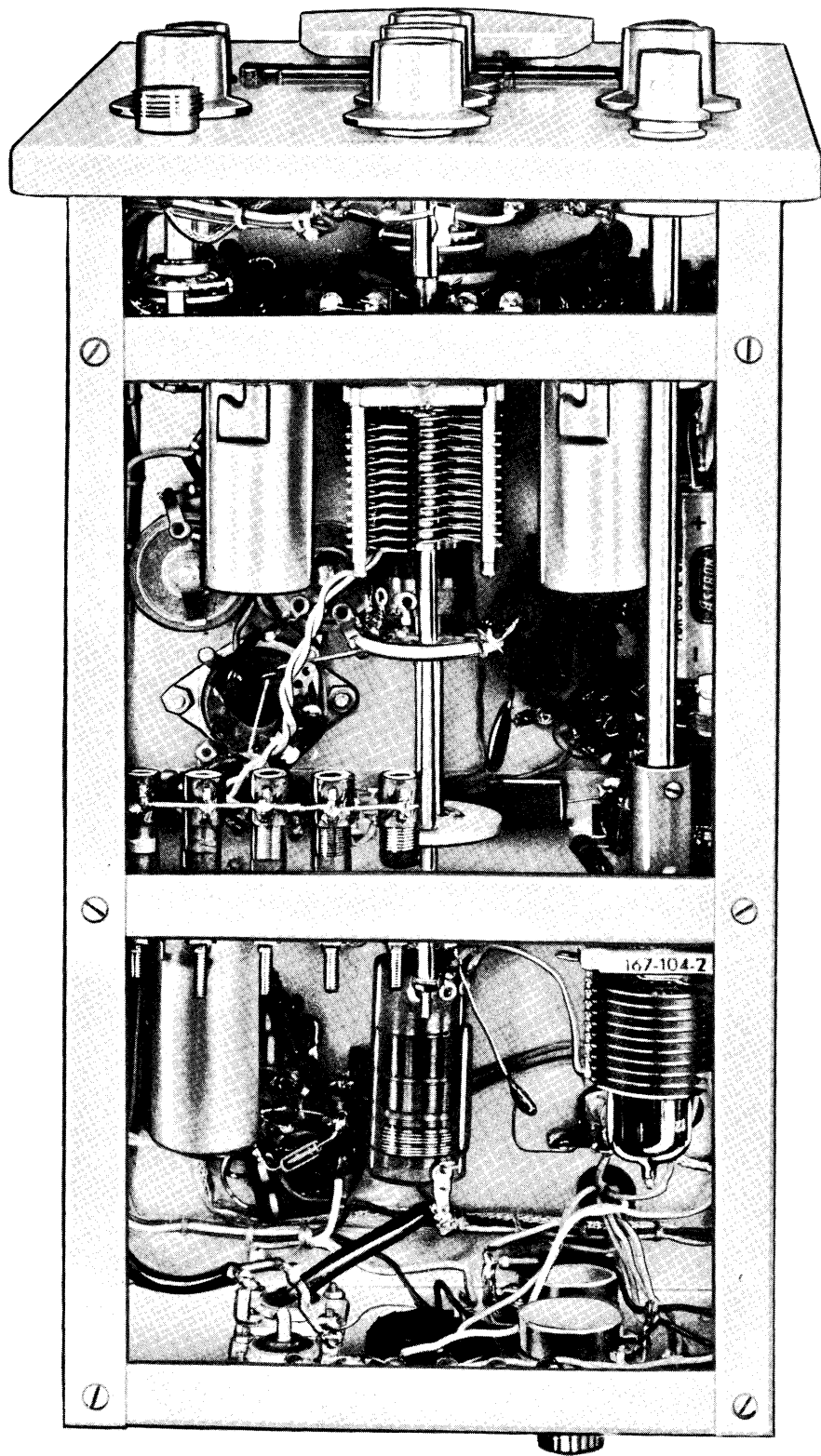

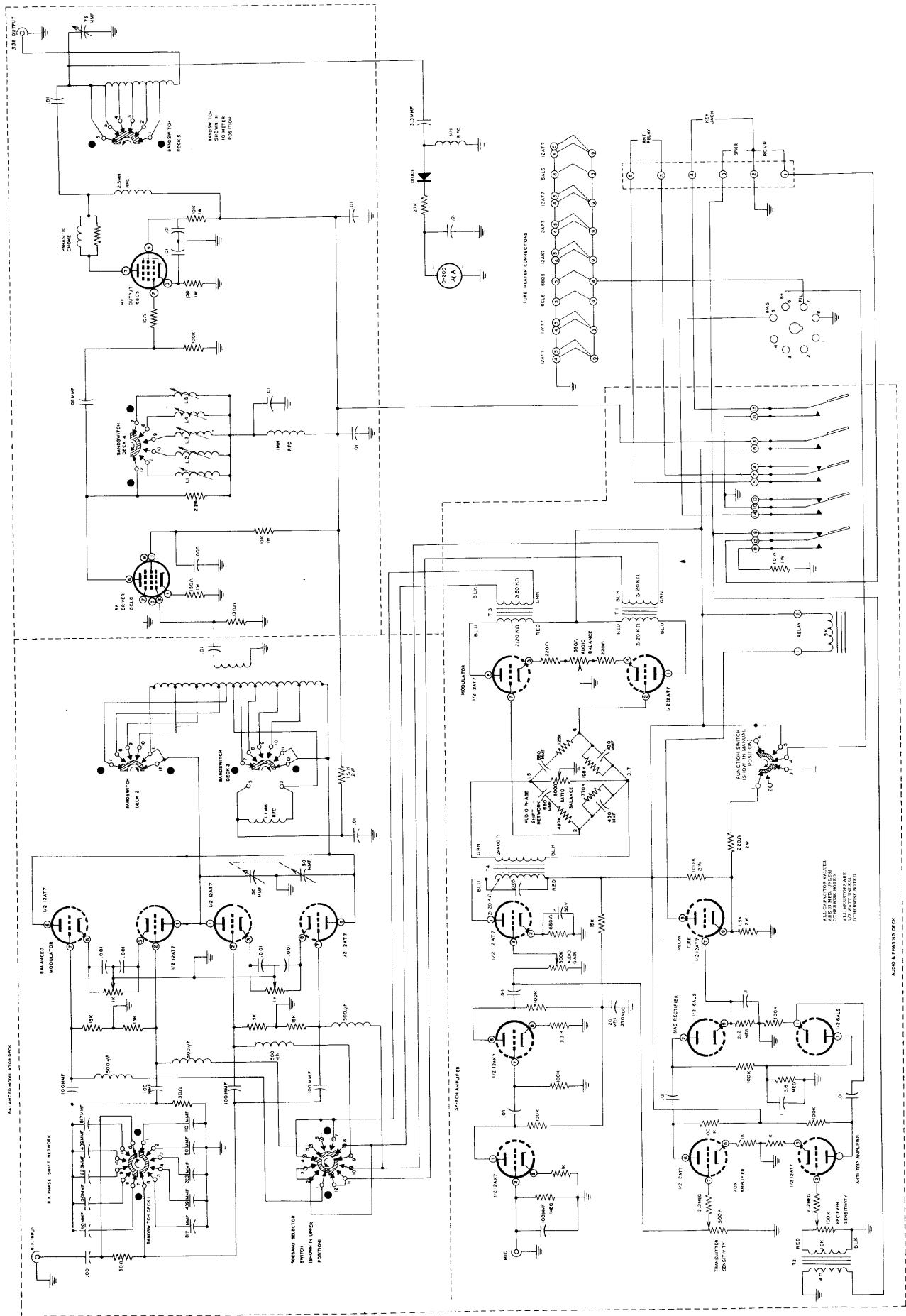

**SCHEMATIC  
HEATHKIT SINGLE SIDEBAND ADAPTER  
MODEL SB-10**

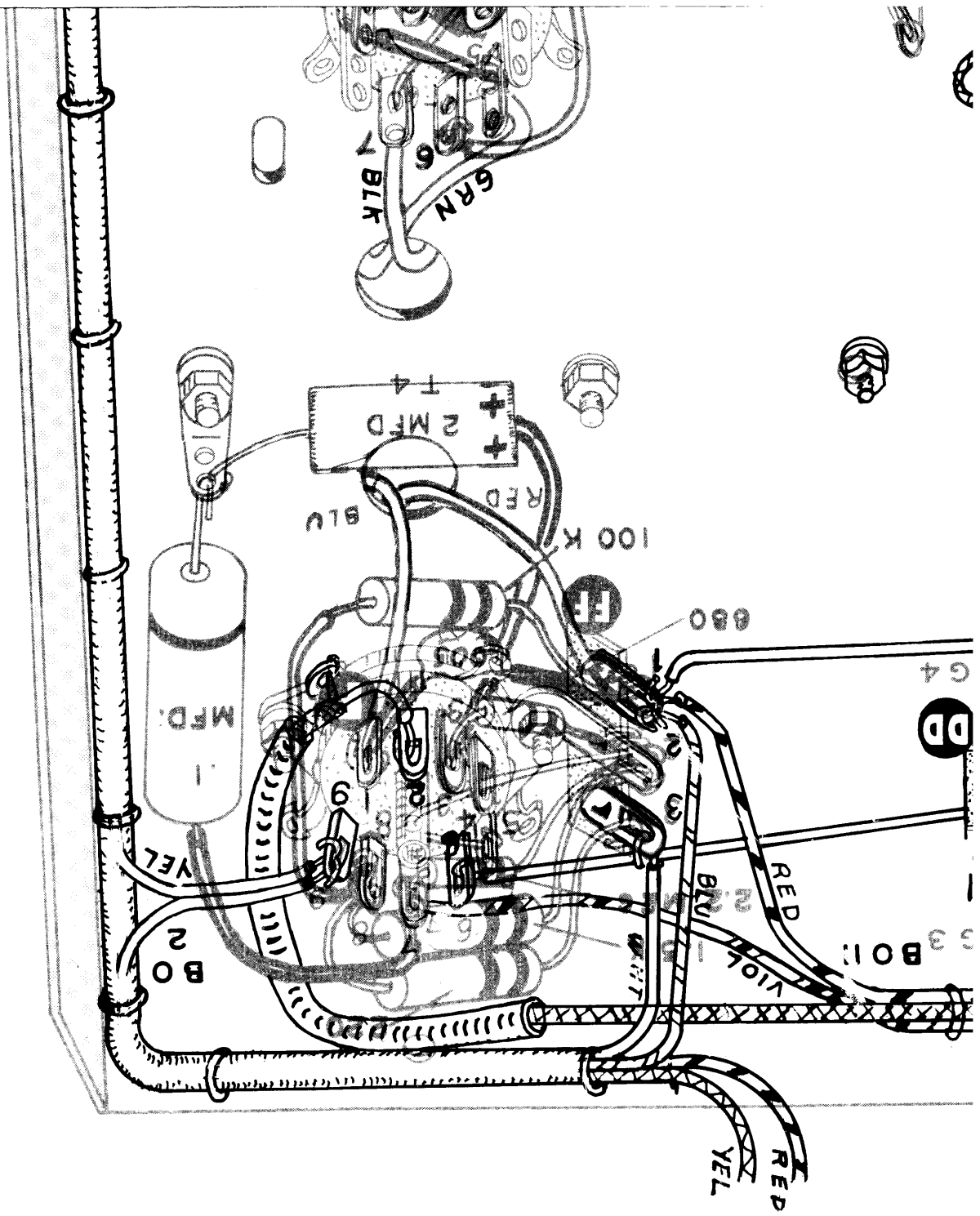

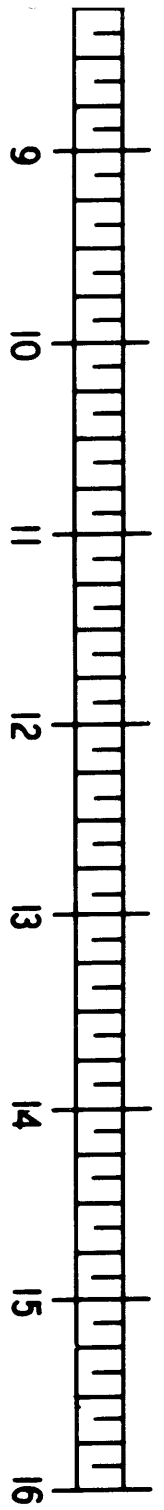
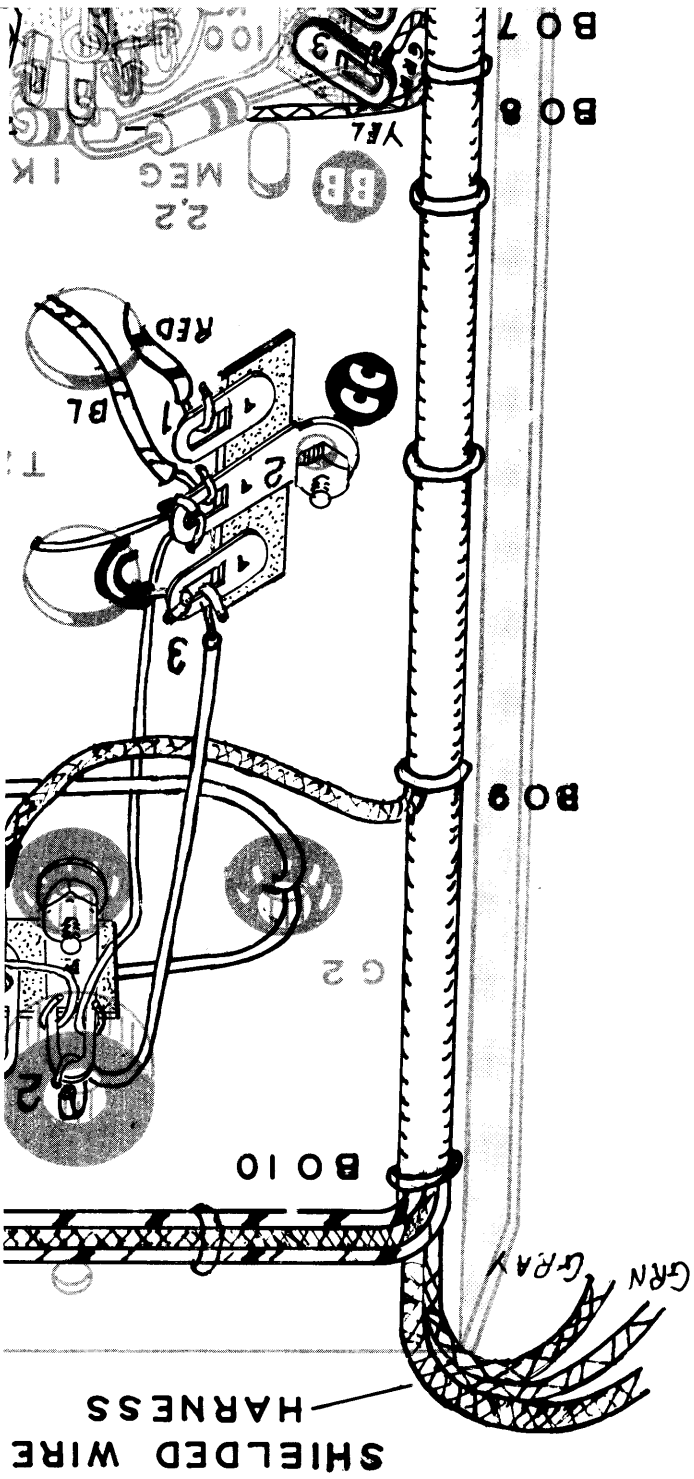

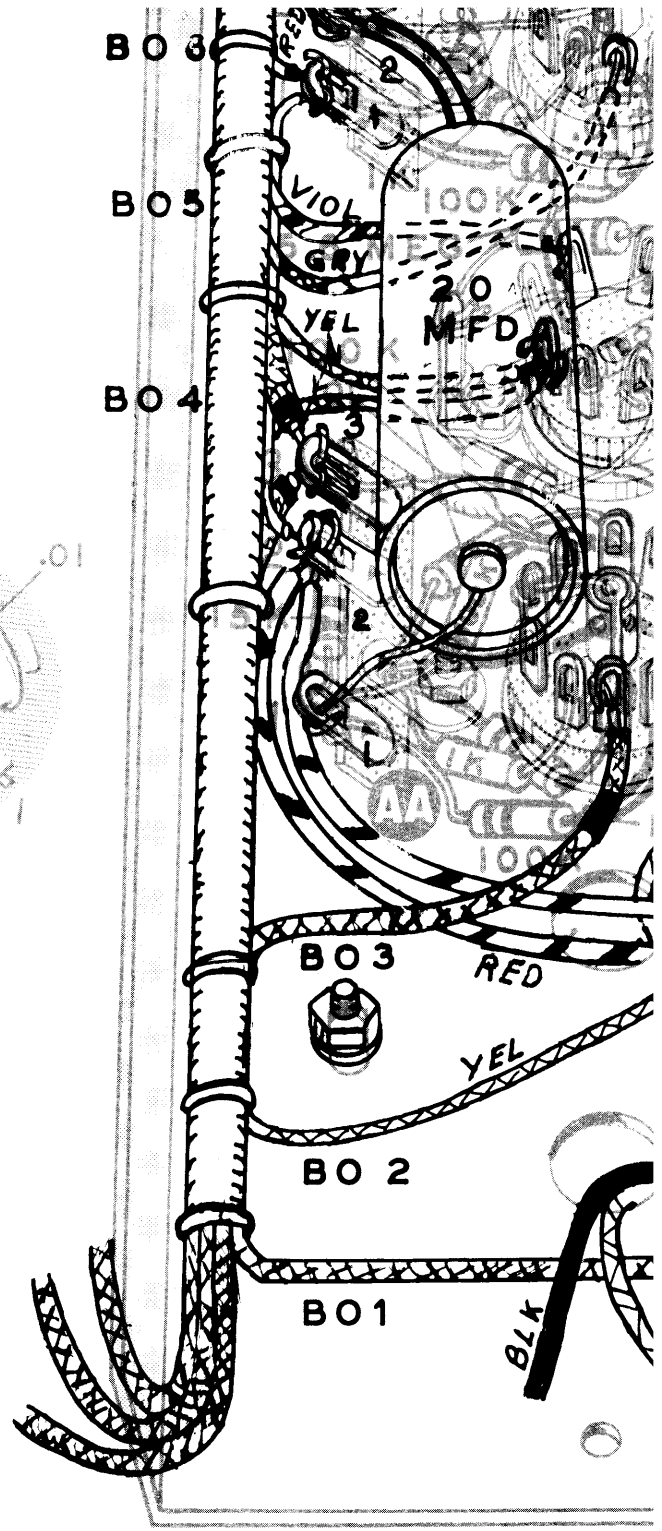
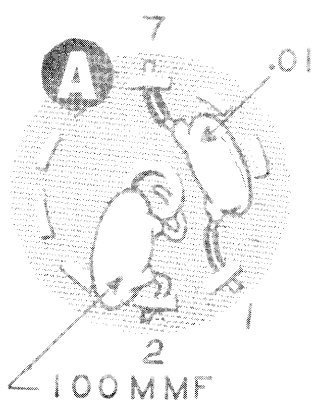
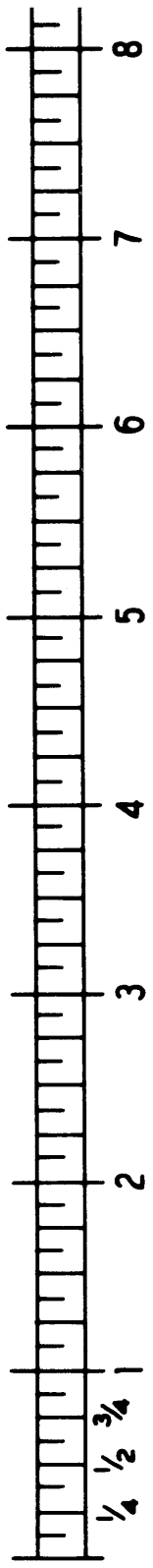

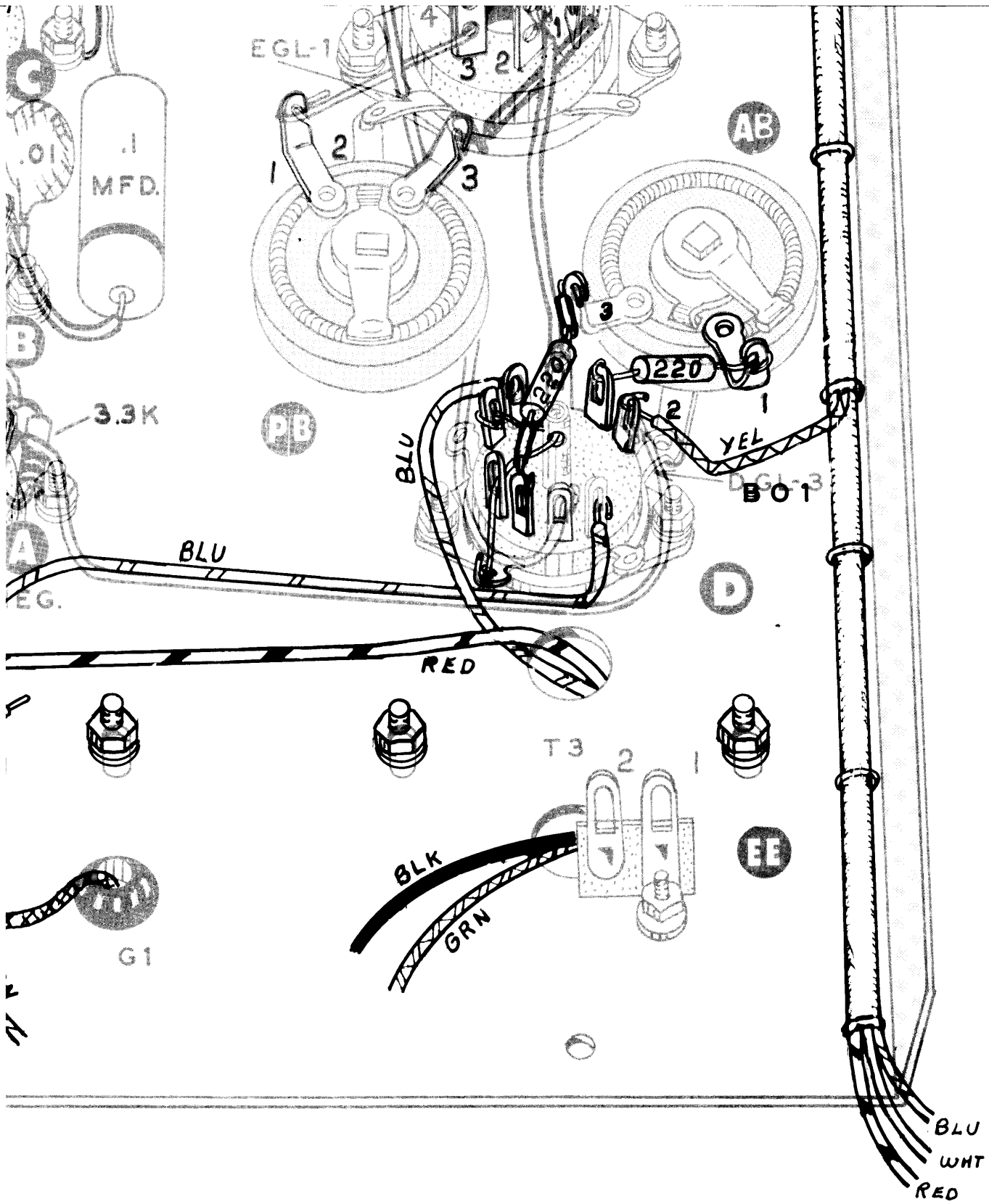

PICTORIAL 3

MODEL SB-10





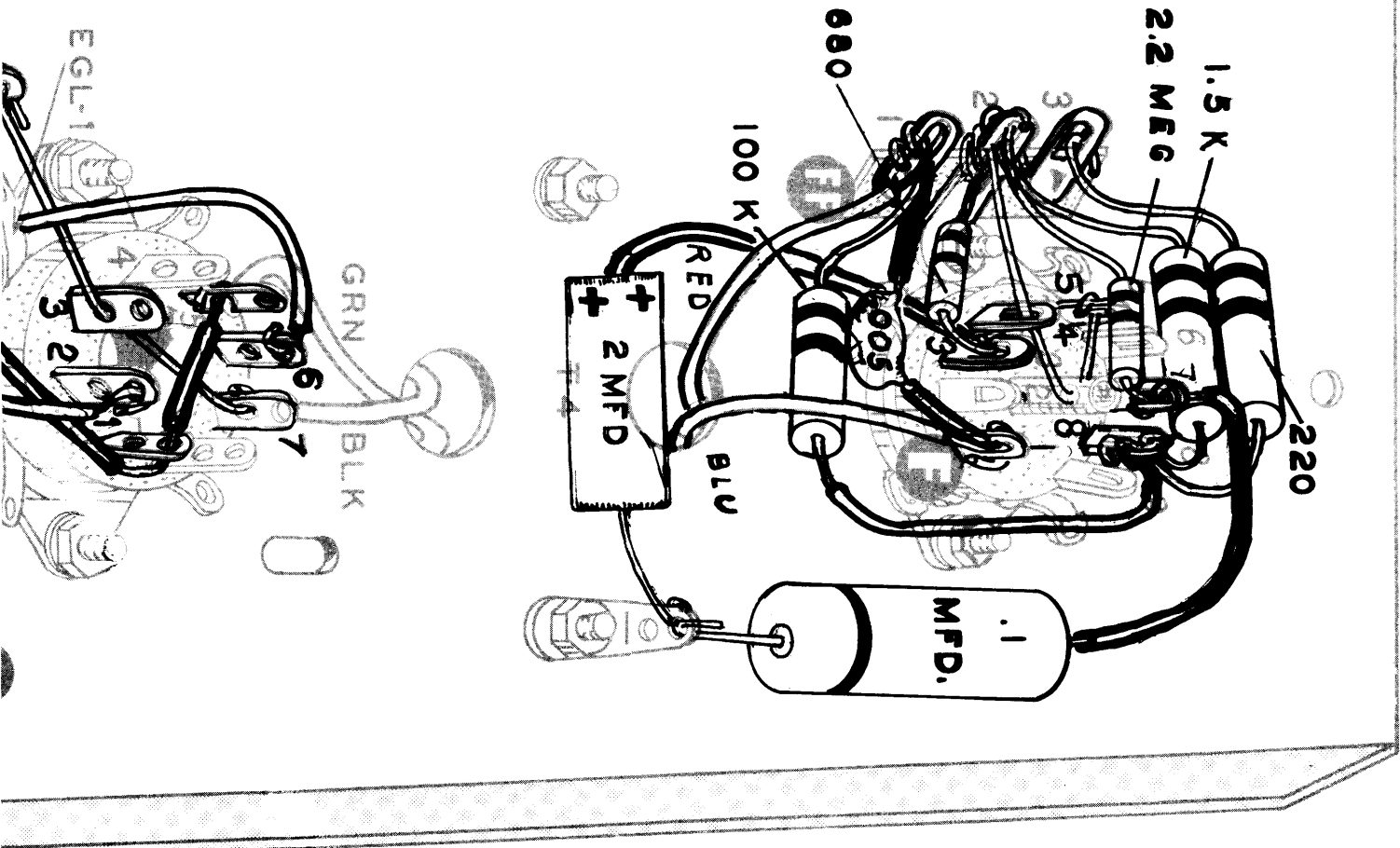
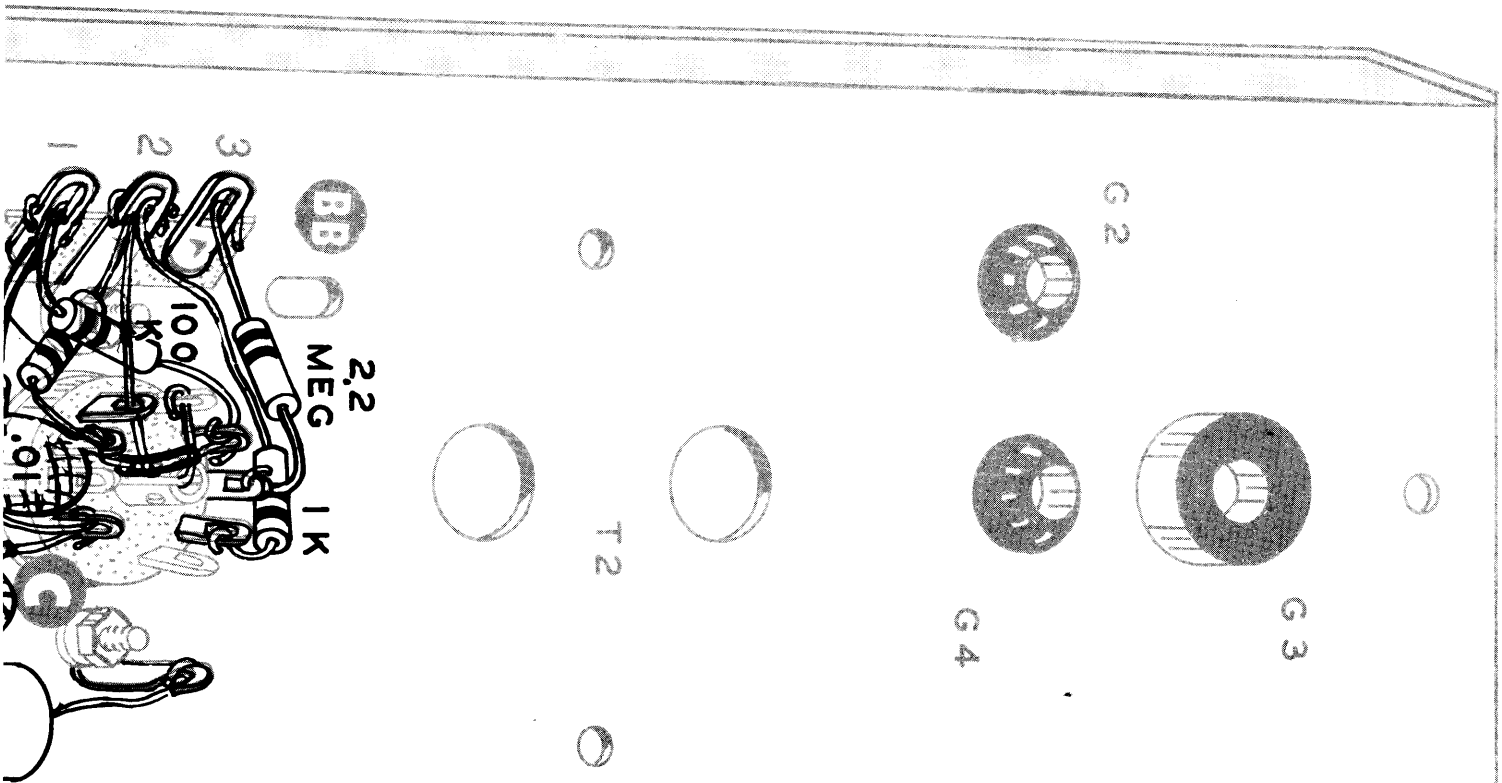

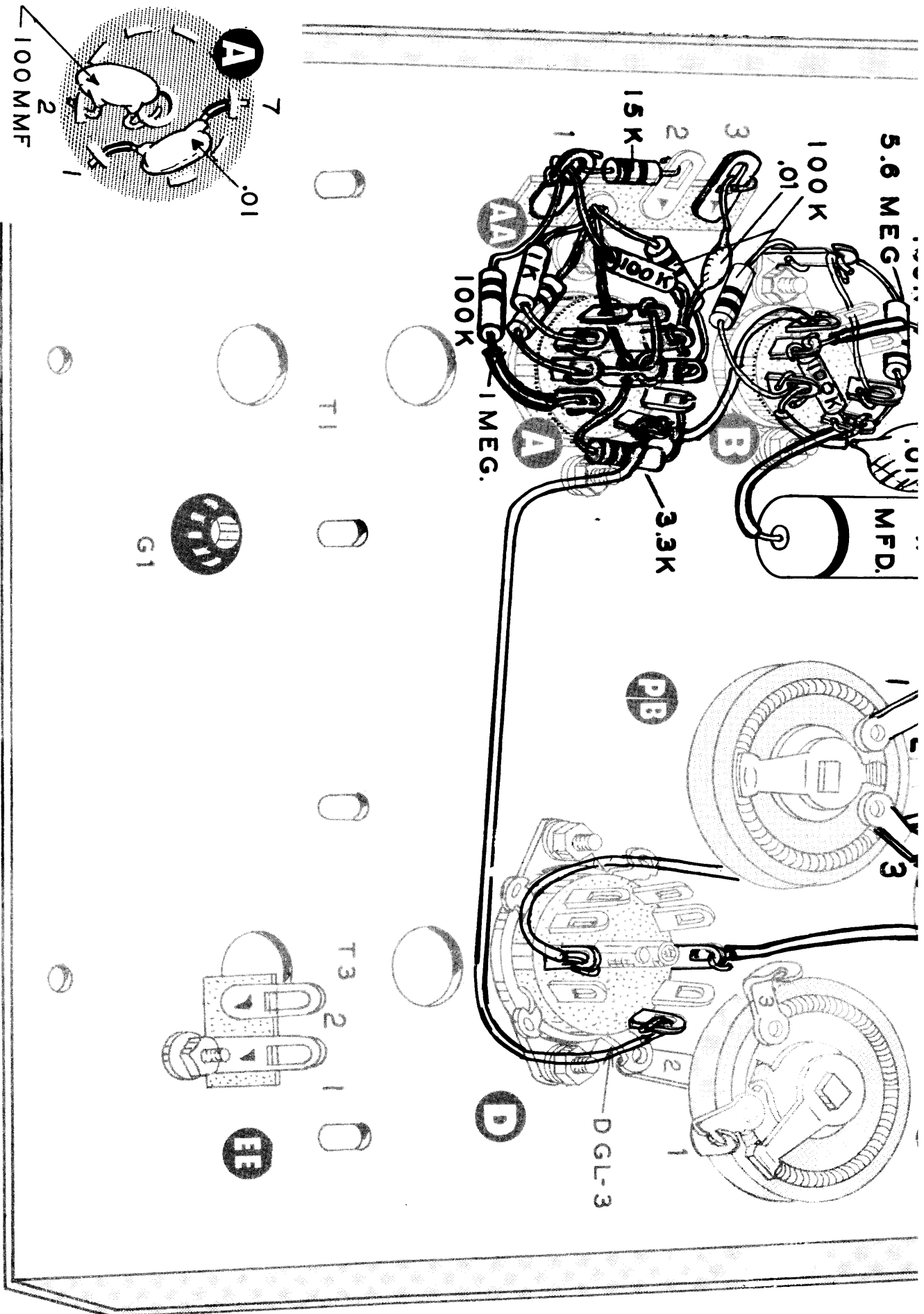

PICTORIAL 2

MODEL SB-10

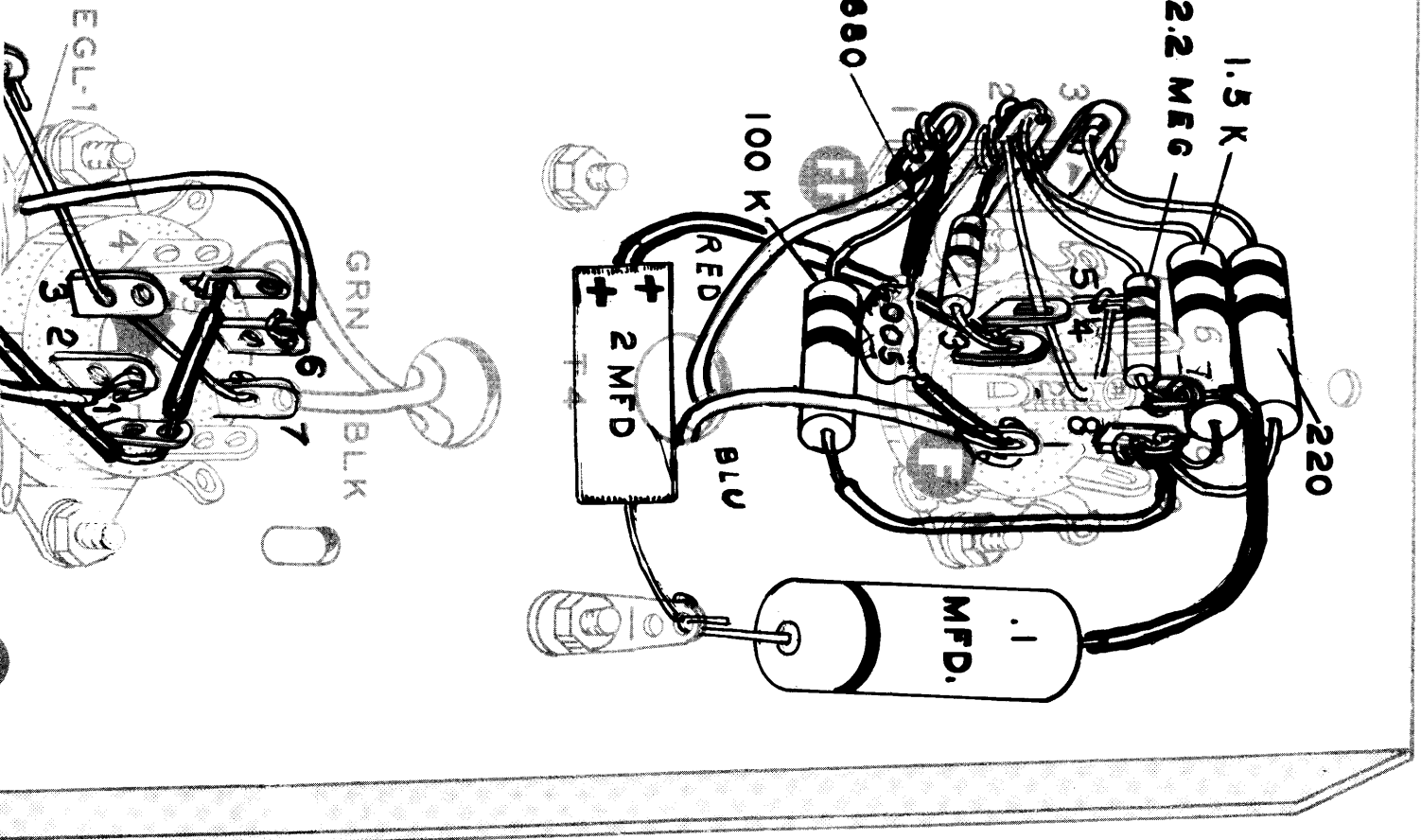
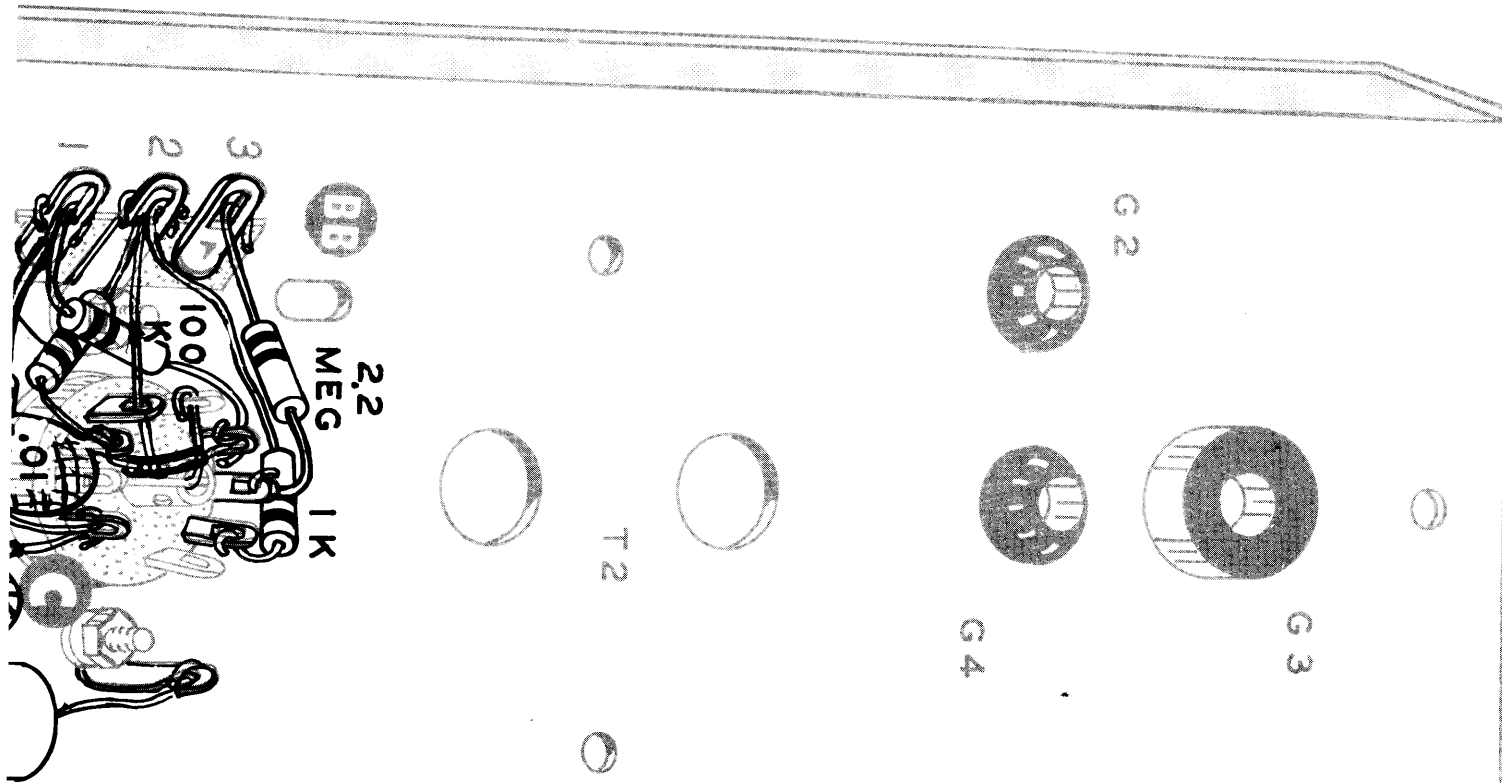

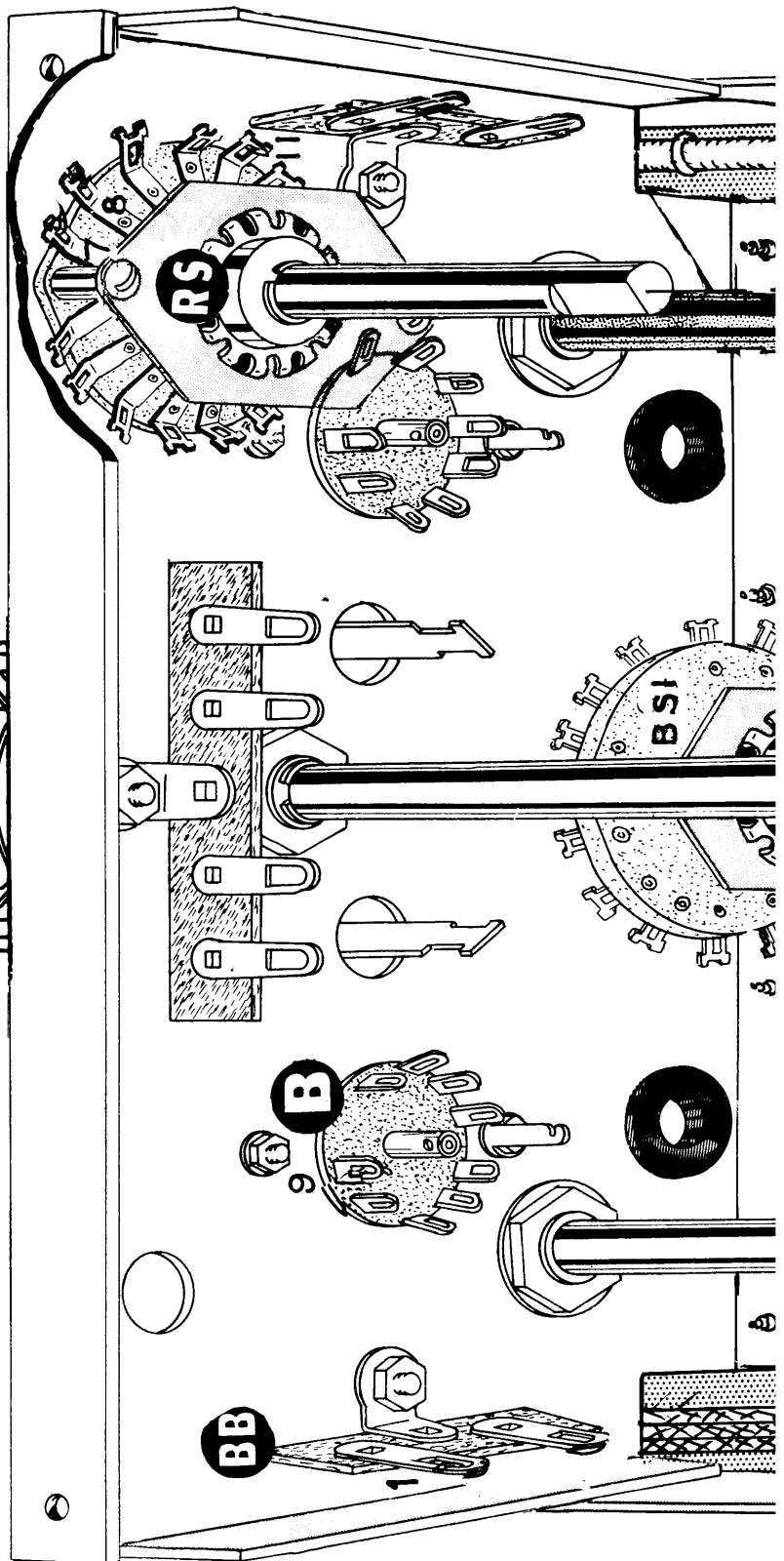
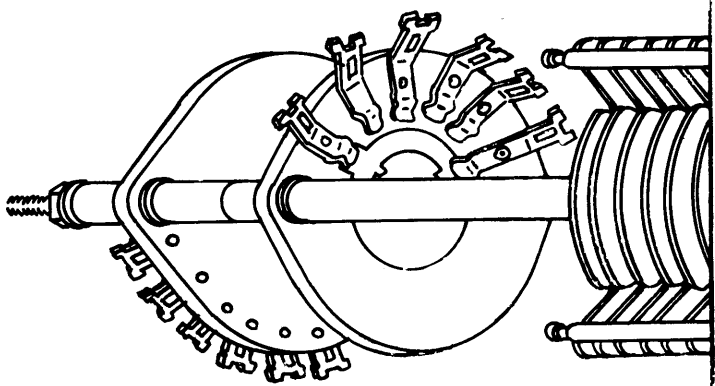

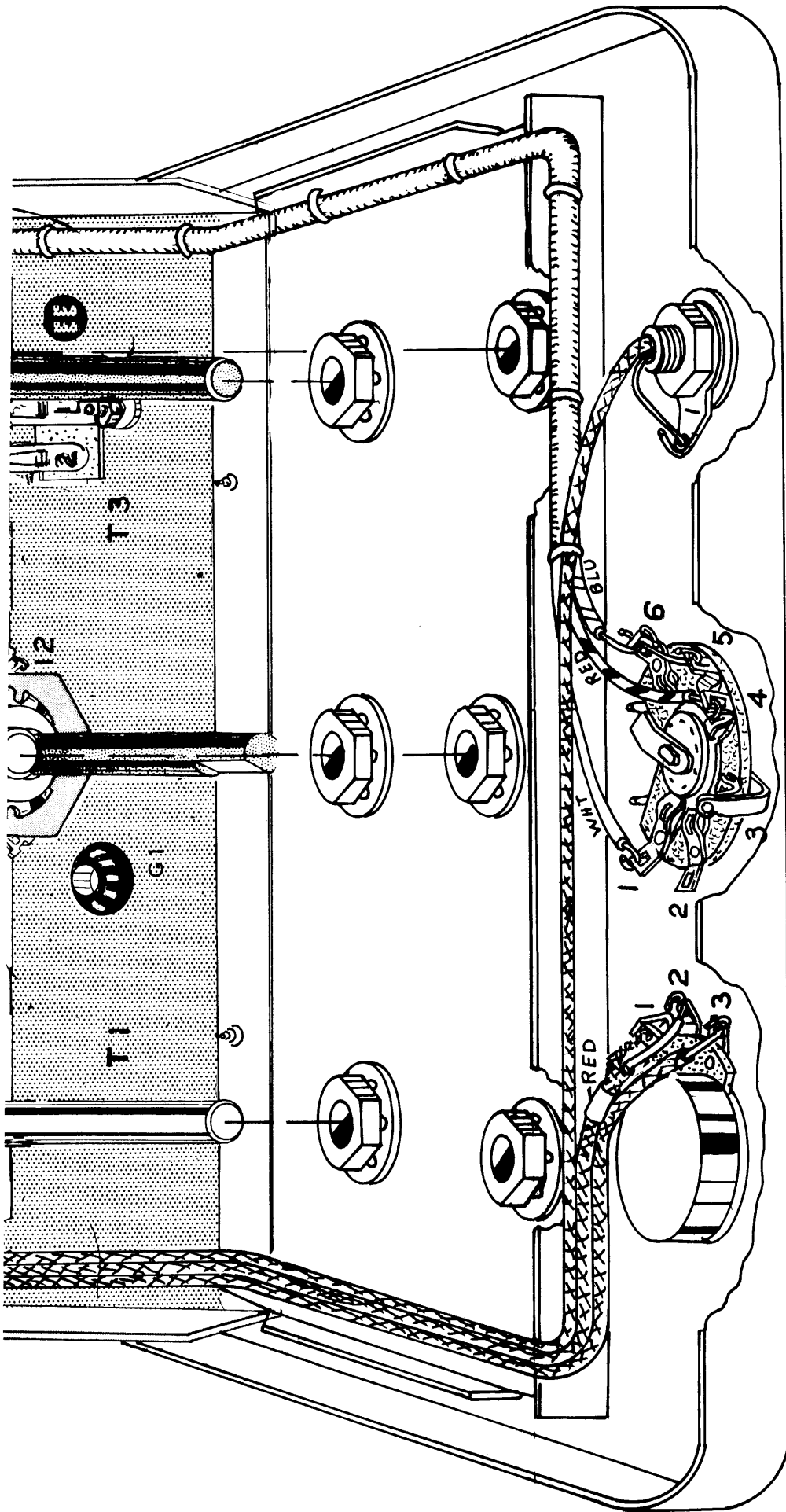
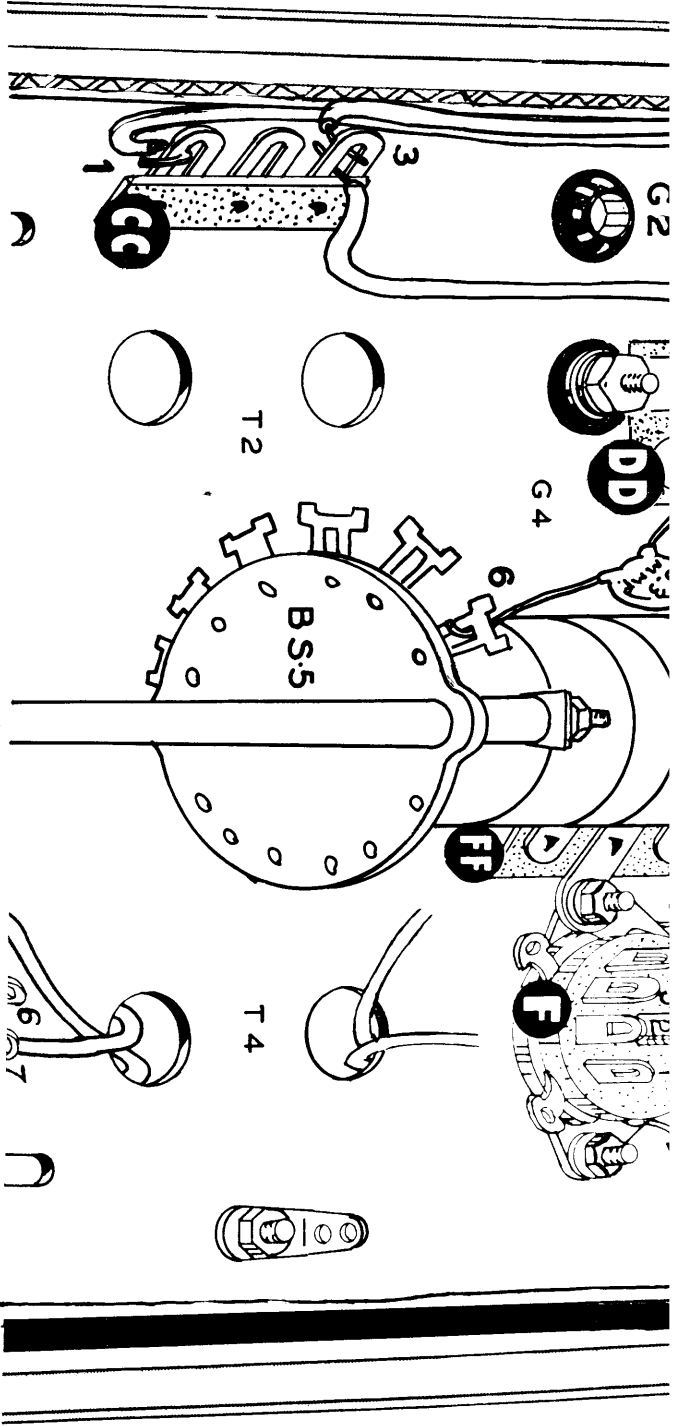
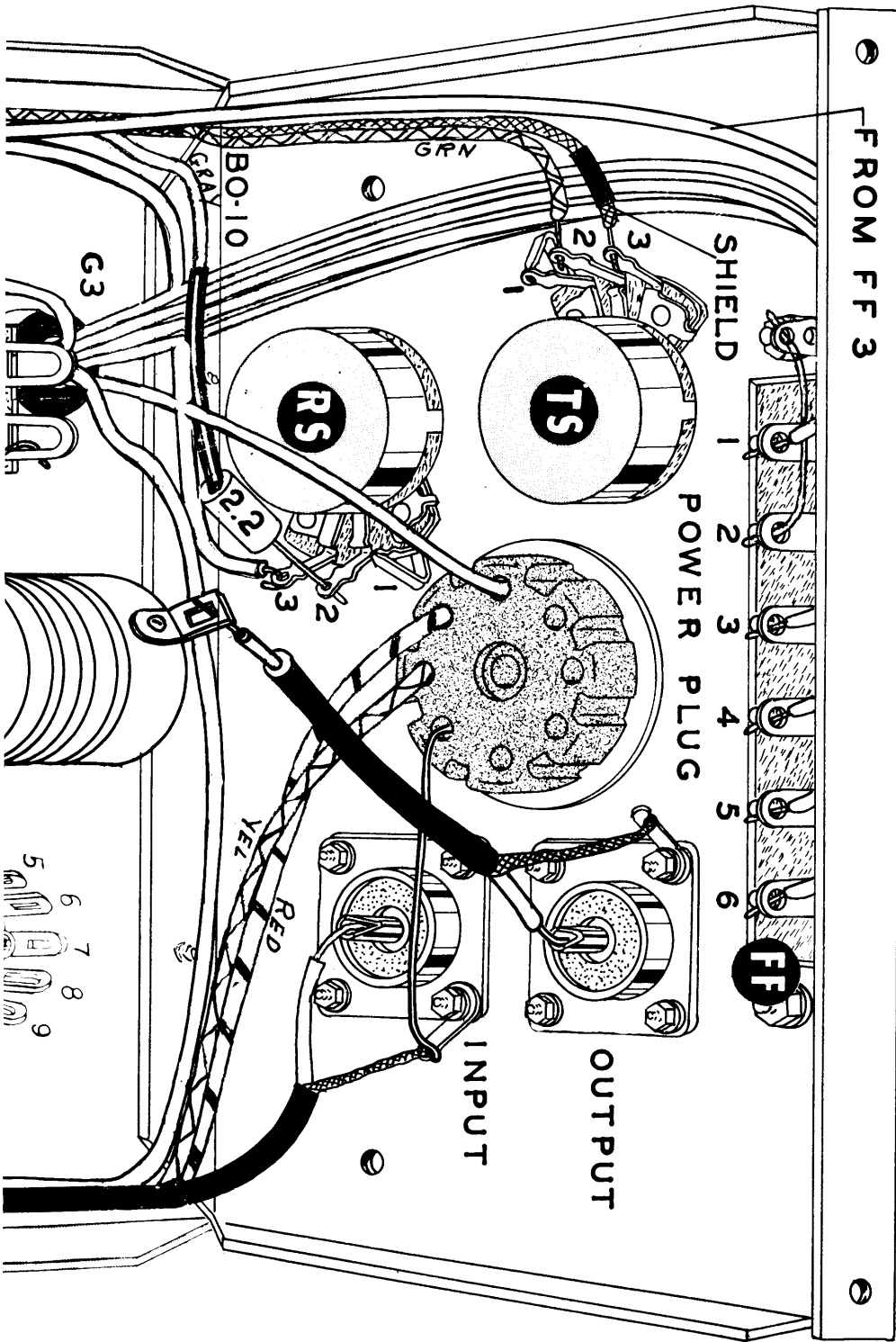

Figure 14



Pictorial 12





PICTORIAL 5

75 MMF TUNING  
CAPACITOR

NOTE: FOR FURTHER COIL IDENTIFICATION,  
L1 HAS FINEST WIRE AND MOST TURNS AND  
L5 HAS HEAVIEST WIRE AND LEAST TURNS.

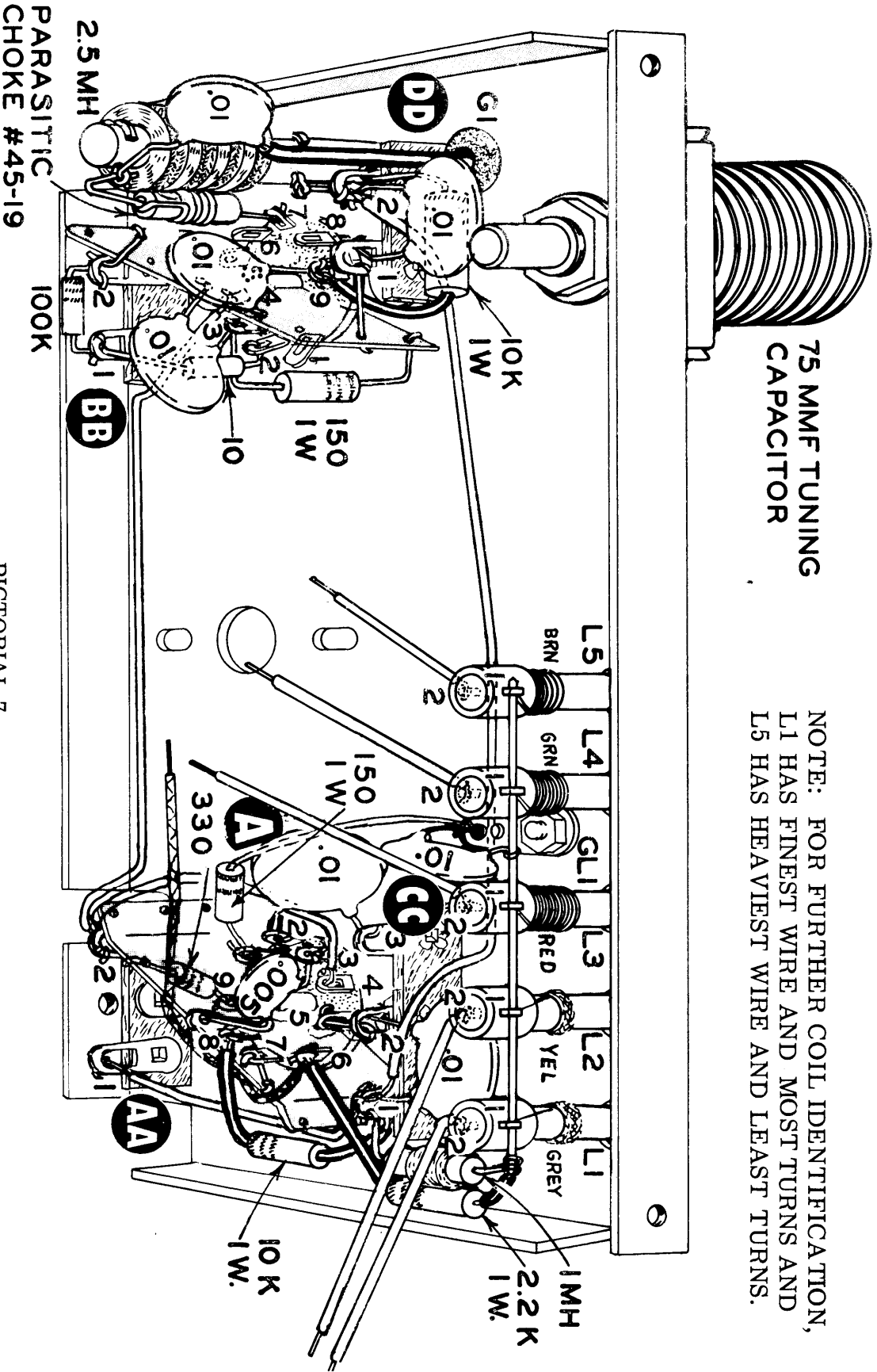

PICTORIAL 7

MODEL SB-10

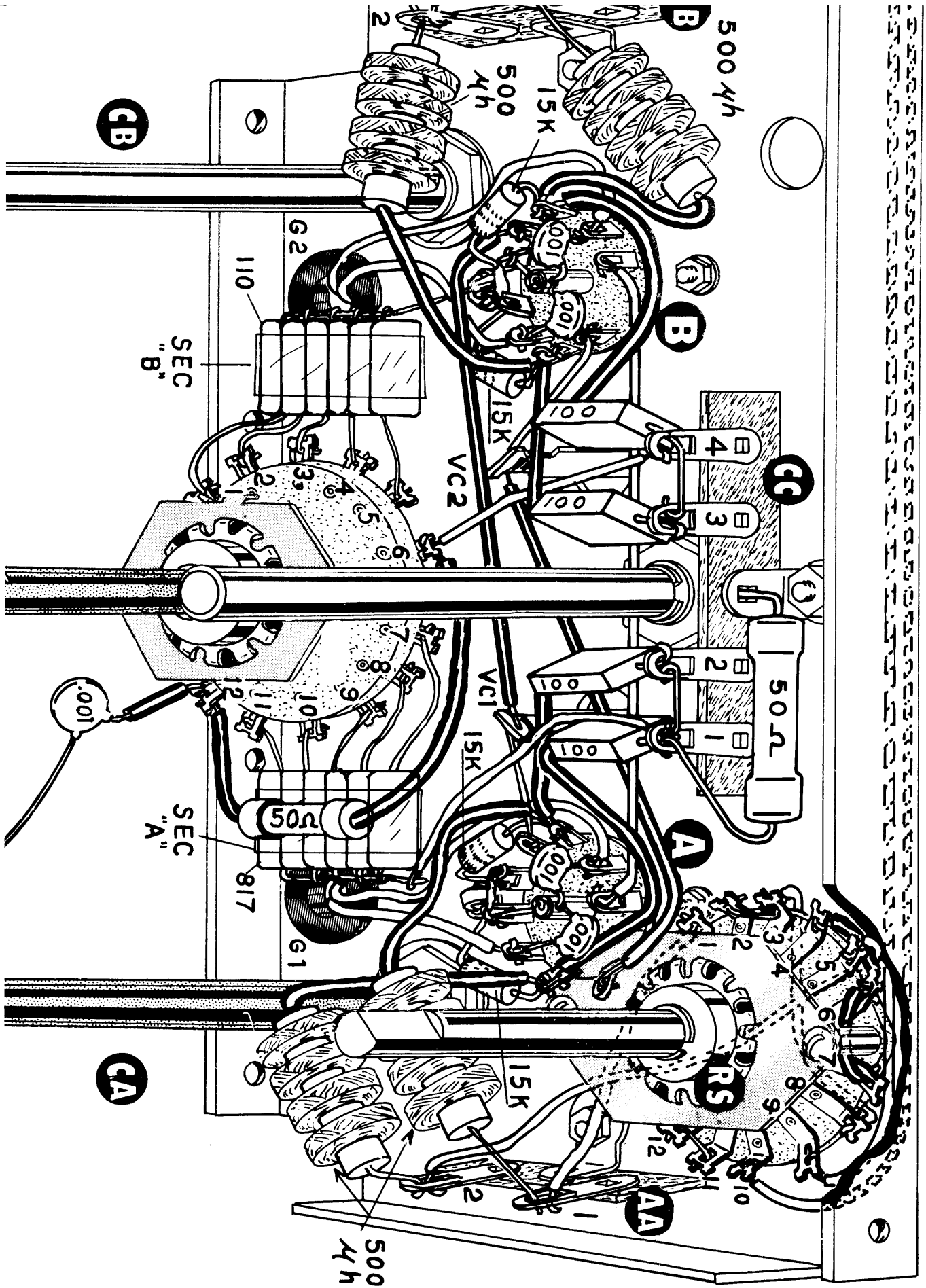

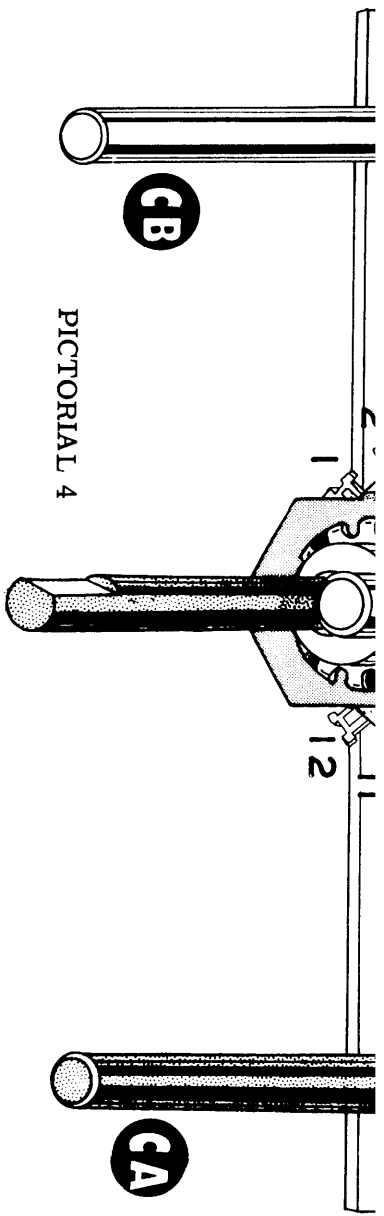

PICTORIAL 4

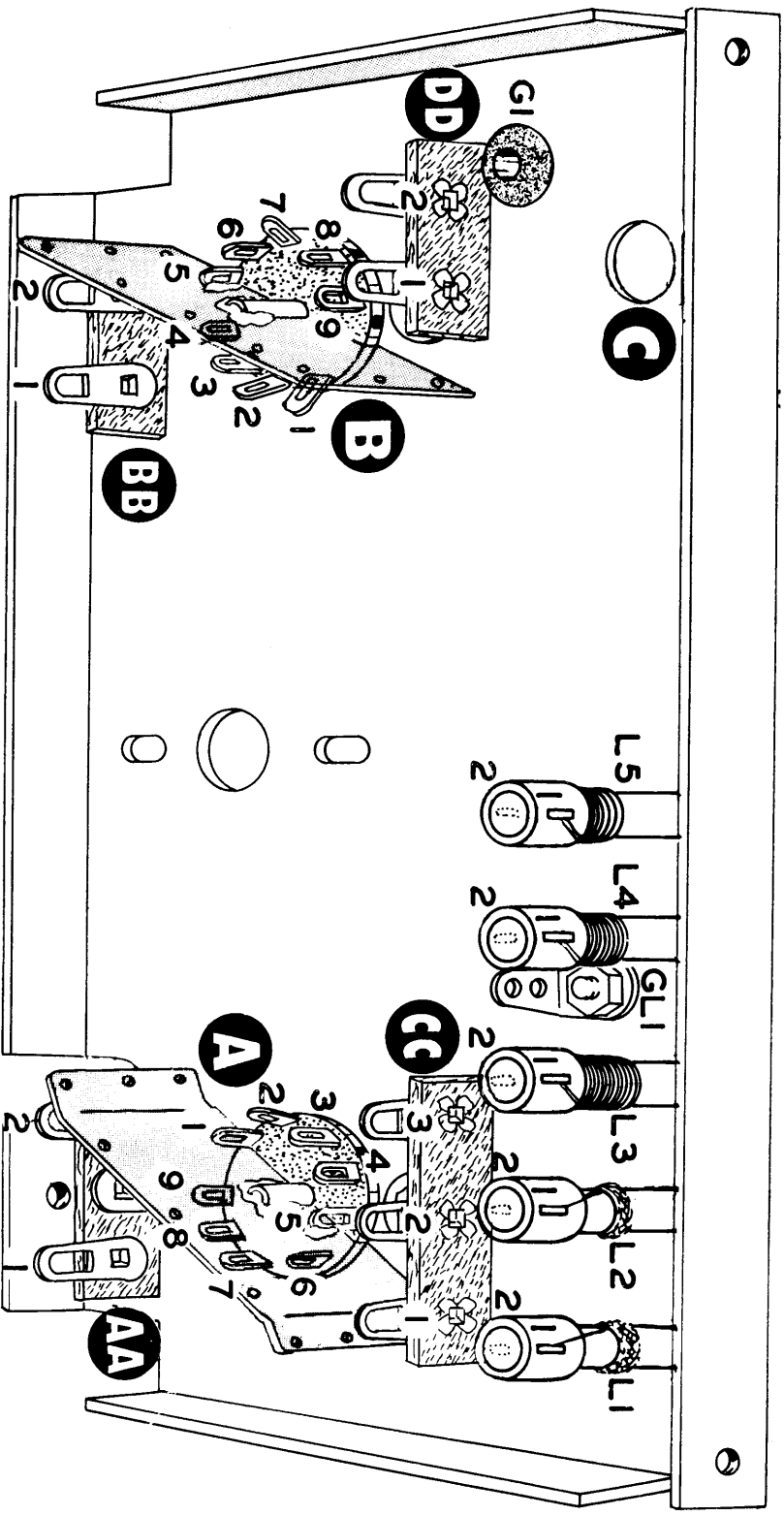

PICTORIAL 6

