

N°314

PRICE \$2.00

HEATHKIT® ASSEMBLY MANUAL



TRANSISTORIZED REGULATED
POWER SUPPLY

MODEL IP-20



HEATH COMPANY BENTON HARBOR MICHIGAN

RESISTOR AND CAPACITOR COLOR CODES

RESISTORS

The colored bands around the body of a color coded resistor represent its value in ohms. These colored bands are grouped toward one end of the resistor body. Starting with this end of the resistor, the first band represents the first digit of the resistance value; the second band represents the second digit; the third band represents the number by which the first two digits are multiplied. A fourth band of gold or silver represents a tolerance of $\pm 5\%$ or $\pm 10\%$ respectively. The absence of a fourth band indicates a tolerance of $\pm 20\%$.

The physical size of a composition resistor is related to its wattage rating. Size increases progressively as the wattage rating is increased. The diameters of 1/2 watt, 1 watt and 2 watt resistors are approximately 1/8", 1/4" and 5/16", respectively.

The color code chart and examples which follow provide the information required to identify color coded resistors.

COLOR	CODE		MULTIPLIER
	1ST DIGIT	2ND DIGIT	
BLACK	0	0	1
BROWN	1	1	10
RED	2	2	100
ORANGE	3	3	1,000
YELLOW	4	4	10,000
GREEN	5	5	100,000
BLUE	6	6	1,000,000
VIOLET	7	7	10,000,000
GRAY	8	8	100,000,000
WHITE	9	9	1,000,000,000
GOLD	-	-	.1
SILVER	-	-	.01

EXAMPLES

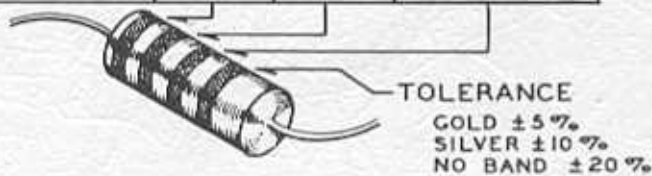
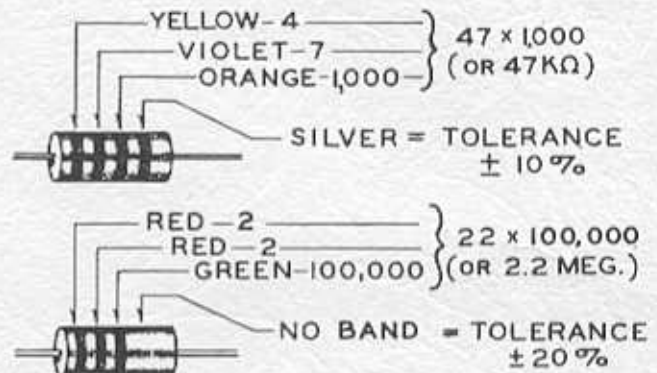

CAPACITORS

Generally, only mica and tubular ceramic capacitors, used in modern equipment, are color coded. The color codes differ somewhat among capacitor manufacturers, however the codes

shown below apply to practically all of the mica and tubular ceramic capacitors that are in common use. These codes comply with EIA (Electronics Industries Association) Standards.

MICA

COLOR	CODE		MULTIPLIER	TOLER. %
	1st DIGIT	2nd DIGIT		
BLACK	0	0	1	±20
BROWN	1	1	10	±20
RED	2	2	100	±2
ORANGE	3	3	1,000	±3
YELLOW	4	4	10,000	±5
GREEN	5	5	—	—
BLUE	6	6	—	—
VIOLET	7	7	—	—
GRAY	8	8	—	—
WHITE	9	9	—	—
GOLD	-	-	.1	±10
SILVER	-	-	.01	±10

EXAMPLE

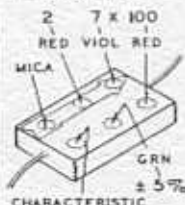

2700 pF ±5%
OR .0027 μF

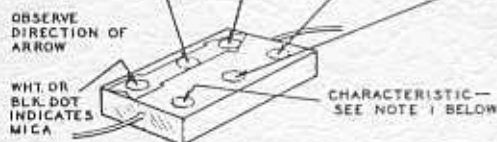

(VALUE IN μF—SEE NOTE 3 BELOW)

TUBULAR CERAMIC

Place the group of rings or dots to the left and read from left to right.

COLOR	CODE		MULTIPLIER	TOLER. %	
	1st DIGIT	2nd DIGIT		NO. OF RINGS	OVERALL
BLACK	0	0	1	±20	±20
BROWN	1	1	10	±0.1	±1
RED	2	2	100	—	±2
ORANGE	3	3	1,000	—	±2.5
YELLOW	4	4	10,000	—	—
GREEN	5	5	—	±0.5	±5
BLUE	6	6	—	—	—
VIOLET	7	7	—	—	—
GRAY	8	8	—	±0.25	—
WHITE	9	9	—	±1.0	±10

EXAMPLE

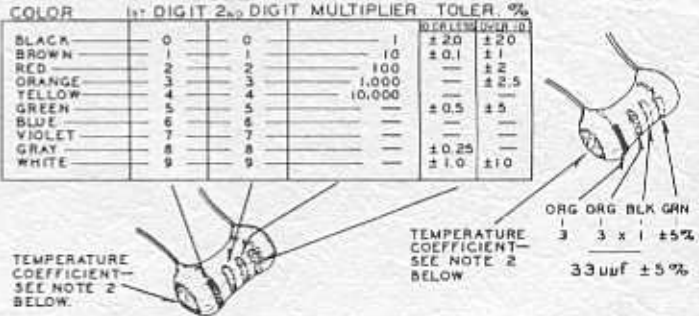

TEMPERATURE COEFFICIENT—SEE NOTE 2 BELOW.

TEMPERATURE COEFFICIENT—SEE NOTE 2 BELOW.

(VALUE IN μF—SEE NOTE 3 BELOW)

NOTES:

1. The characteristic of a mica capacitor is the temperature coefficient, drift capacitance and insulation resistance. This information is not usually needed to identify a capacitor but, if desired, it can be obtained by referring to EIA Standard, RS-153 (a Standard of Electronic Industries Association.)

2. The temperature coefficient of a capacitor is the predictable change in capacitance with temperature change and is

expressed in parts per million per degree centigrade. Refer to EIA Standard, RS-198 (a Standard of Electronic Industries Association.)

3. The farad is the basic unit of capacitance, however capacitor values are generally expressed in terms of μF (microfarad, .000001 farad) and μμF (micro-micro-farad, .000001 μF); therefore, 1,000 μμF = .001 μF, 1,000,000 μμF = 1 μF.

USING A PLASTIC NUT STARTER

A plastic nut starter offers a convenient method of starting the most used sizes: 3/16" and 1/4" (3-48 and 6-32). When the correct end is pushed down over a nut, the pliable tool conforms to the shape of the nut and the nut is gently held while it is being picked up and started on the screw. The tool should only be used to start the nut.

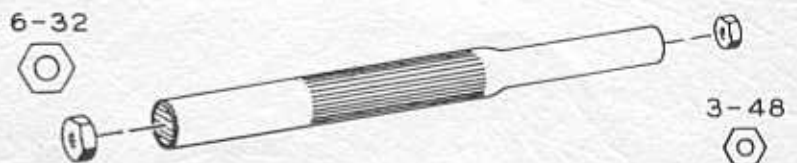

Assembly
and
Operation
of the



TRANSISTORIZED
REGULATED
POWER SUPPLY

MODEL IP-20



HEATH COMPANY,
BENTON HARBOR,
MICHIGAN

 a subsidiary of
DAYSTROM, INCORPORATED

TABLE OF CONTENTS

Specifications	2
Introduction	3
Circuit Description	3
Schematic	5*
Construction Notes	6
Parts List	7
Proper Soldering Techniques	9
Step-By-Step Procedure	10
Step-By-Step Assembly	10
Main Chassis Parts Mounting	10
Control Plate Parts Mounting-Wiring	12
Voltage Range Switch Wiring	14
Current Range Switch Wiring	17
Initial Wiring on Main Chassis	18
Final Wiring on Main Chassis Top	26
Final Wiring Checkout	28
Initial Test And Adjustment	29
Final Assembly	30
Final Adjustment	31
Operation	32
In Case Of Difficulty	34
Troubleshooting Chart	34
Service Information	35
Service	35
Replacements	36
Shipping Instructions	36
Warranty	37

*Fold-out from page.

All prices are subject to change without notice. The Heath Company reserves the right to discontinue instruments and to change specifications at any time without incurring any obligation to incorporate new features in instruments previously sold.

Figure 2

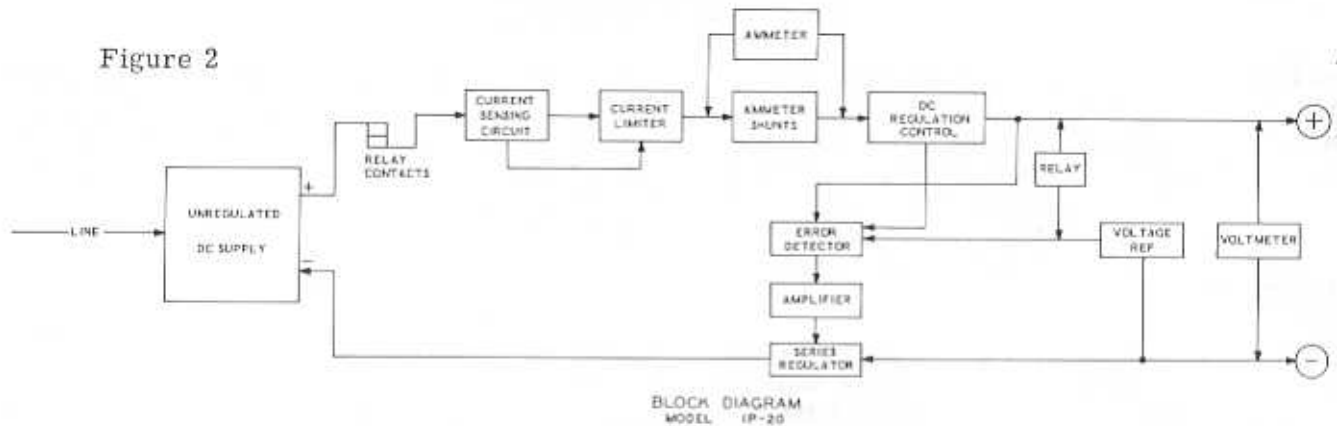

FEEDBACK CIRCUIT (FIGURE 3)

It is difficult to obtain an ideal voltage regulator. Therefore, a positive feedback circuit is used to assist in the voltage regulation process just described. Again assume that the output voltage tends to drop due to an increase in the load current. A voltage change is produced across R16 of the polarity as shown in Figure 3. This voltage further aids in reducing the current in transistor X2, which in turn produces more output current as described previously. This improves the regulation of the Power Supply. If R16 is adjusted at 15 volts output for no change from no load to full load, all other voltage settings will be within 15 millivolts from no load to full load.

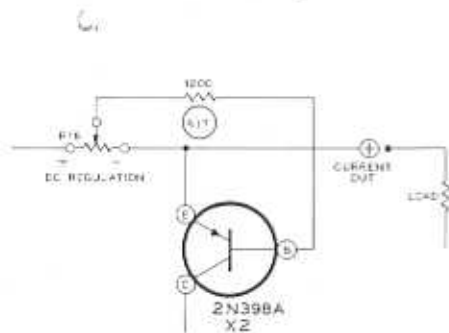

Figure 3

VOLTAGE REFERENCE SOURCE

The voltage reference source is obtained from a separate winding on the power transformer. The AC from the power transformer is rectified by silicon diode D8 and the filter network. The filtered DC voltage passes through the 6 watt 120 volt ballast lamp to OB2 voltage regulator tube V1. V1 regulates at a +105 volt level. The DC voltage from V1 is then applied to the 56 volt zener diode and the voltage divider network on the VOLTAGE RANGE switch. A small amount of the regulated voltage from V1 is applied through resistor R46 to transistors X3, X4, and X5 for bias. The zener current can be measured by placing the METER switch on the control mounting plate in the ZENER CURRENT position. The ZENER CURRENT Adjust control is then set to produce 5 ma (full scale) of Zener current.

The voltage applied at the base of X2 becomes, essentially, the output voltage. To obtain a variable reference, FINE VOLTAGE control R42 can be lifted from the minus (-) line by rotating the VOLTAGE RANGE switch. The current through R42 is always the same, 25 ma. As the output voltage is increased by rotating the VOLTAGE RANGE switch, this switch also selects higher voltage taps from the transformer.

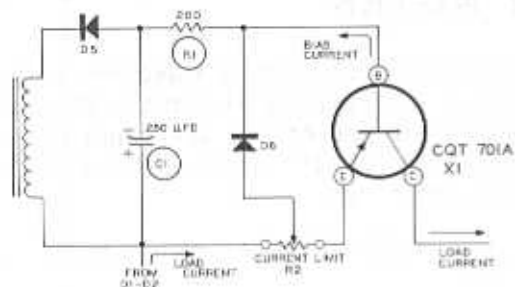

Figure 4

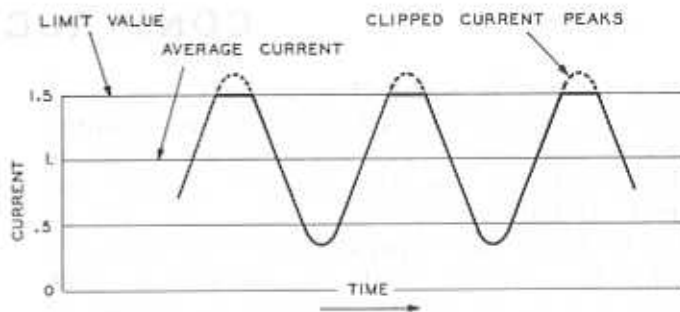

Figure 5

CURRENT LIMITER (FIGURES 4 AND 5)

Transistor X1 normally operates in a saturated state because of bias current from the current limiter winding on the power transformer. When the load current of the Power Supply increases to the current limit control setting, a voltage is developed across silicon diode D6. This causes D6 to start conducting. The setting of R2 determines the point at which D6 will begin to conduct. As soon as D6 begins to conduct, the emitter to base voltage of X1 is fixed and limits the current at the value being delivered.

The current limit resistors are switched by the CURRENT RANGE switch, CR-2. Therefore, the working range of the CURRENT LIMIT control is changed with the CURRENT RANGE switch to provide current limiting on all current ranges.

Figure 5 shows how the current limiter will clip off peaks of the current being delivered to

an electronic load, such as an amplifier. This effect can be reduced or eliminated by placing a very large capacitor (1000 μ fd or more) across the output. However, clipping will not occur if the peak current required does not exceed the CURRENT LIMIT control setting.

OTHER CIRCUITS

The voltmeter is connected to the VOLTAGE RANGE switch and its full scale reading is automatically established to read the output voltage.

The AC output impedance of the Power Supply is reduced by the AC feedback network, using capacitor C3. Capacitors C4 and C6 reduce the AC output impedance as well as hum and noise. They also provide AC stability to the circuit to prevent oscillations. Capacitor C5 provides a low impedance output at high frequencies.

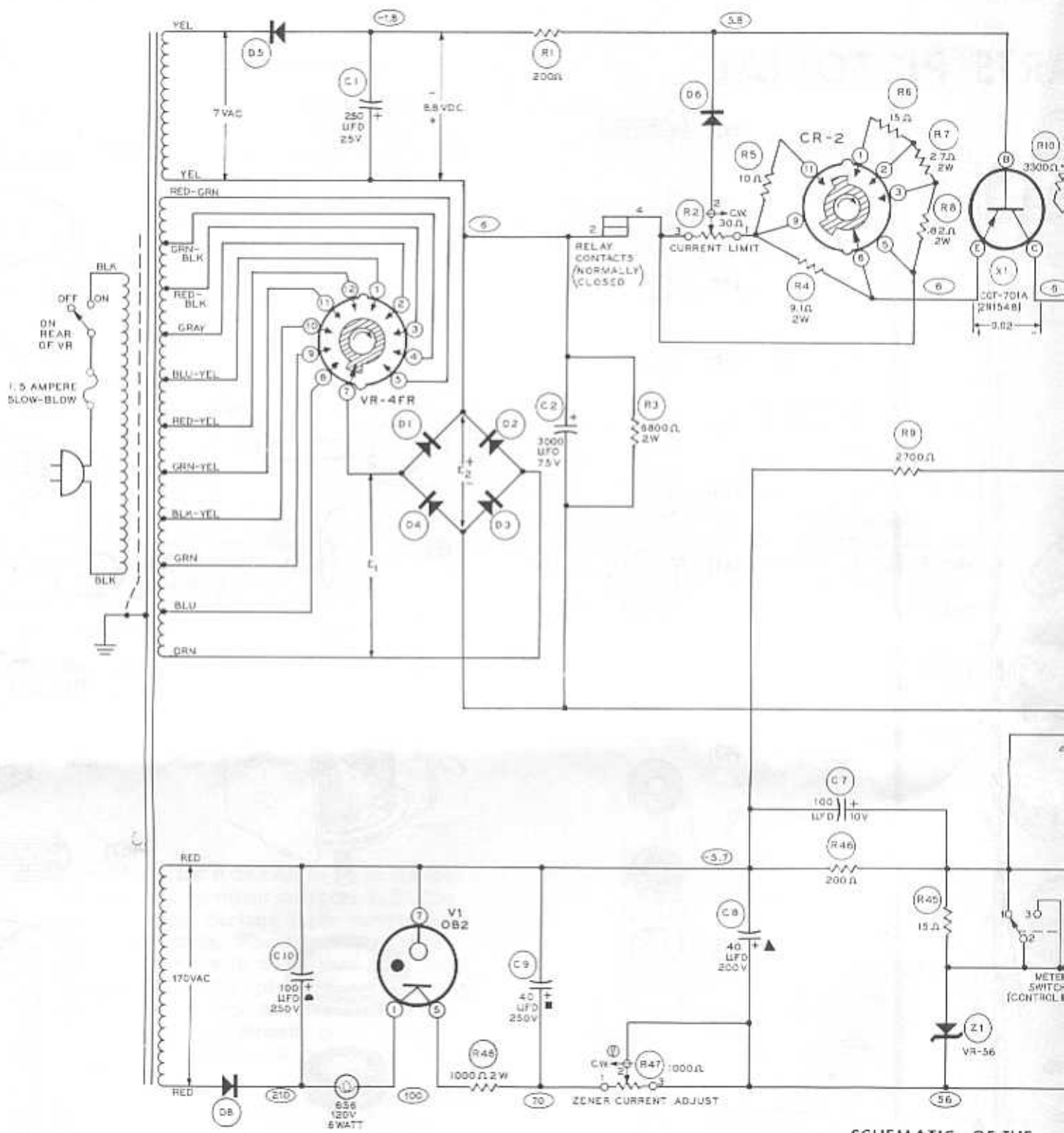

NOTES:

- ALL VOLTAGES TAKEN AT 117 VOLTS, 60 CPS INPUT.
- ALL VOLTAGES READ WITH A VTVM.
- CONTROLS SET AS FOLLOWS FOR VOLTAGE MEASUREMENTS:
 - VOLTAGE RANGE - 5
 - CURRENT RANGE - 1.5 A
 - FINE VOLTAGE - MAX clockwise
 - CURRENT LIMIT - MAX clockwise
 - TOGGLE SWITCH - Reset-standby
 - METER SWITCH - Voltage
- ALL VOLTAGES MEASURED FROM NEGATIVE (-) OUTPUT TERMINAL UNLESS OTHERWISE INDICATED. ○ INDICATES VOLTAGE READING.
- ALL VOLTAGES ARE DC UNLESS OTHERWISE INDICATED.
- VOLTAGE READINGS CAN VARY ±10%.
- OUTPUT UNLOADED.
- ROTARY SWITCHES SHOWN IN MAXIMUM COUNTERCLOCKWISE POSITION.

POSITION OF VR	E1 VOLTS AC	E2 VOLTS DC	E3 VOLTS DC
5	10	14	8
10	15	21	10
15	20	28	15
20	25	35	20
25	29	41	25
30	33	47	30
35	38	54	35
40	43	60	40
45	47	68	45
50	53	74	50

Set controls as in note 3 except for Voltage Range (VR) switch.

**SCHEMATIC OF THE
HEATHKIT®
TRANSISTORIZED REGULATED
POWER SUPPLY
MODEL IP-20**

ALL RESISTANCES IN OHMS X = 1000.
ALL RESISTORS 1/2 WATT UNLESS OTHERWISE SPECIFIED.

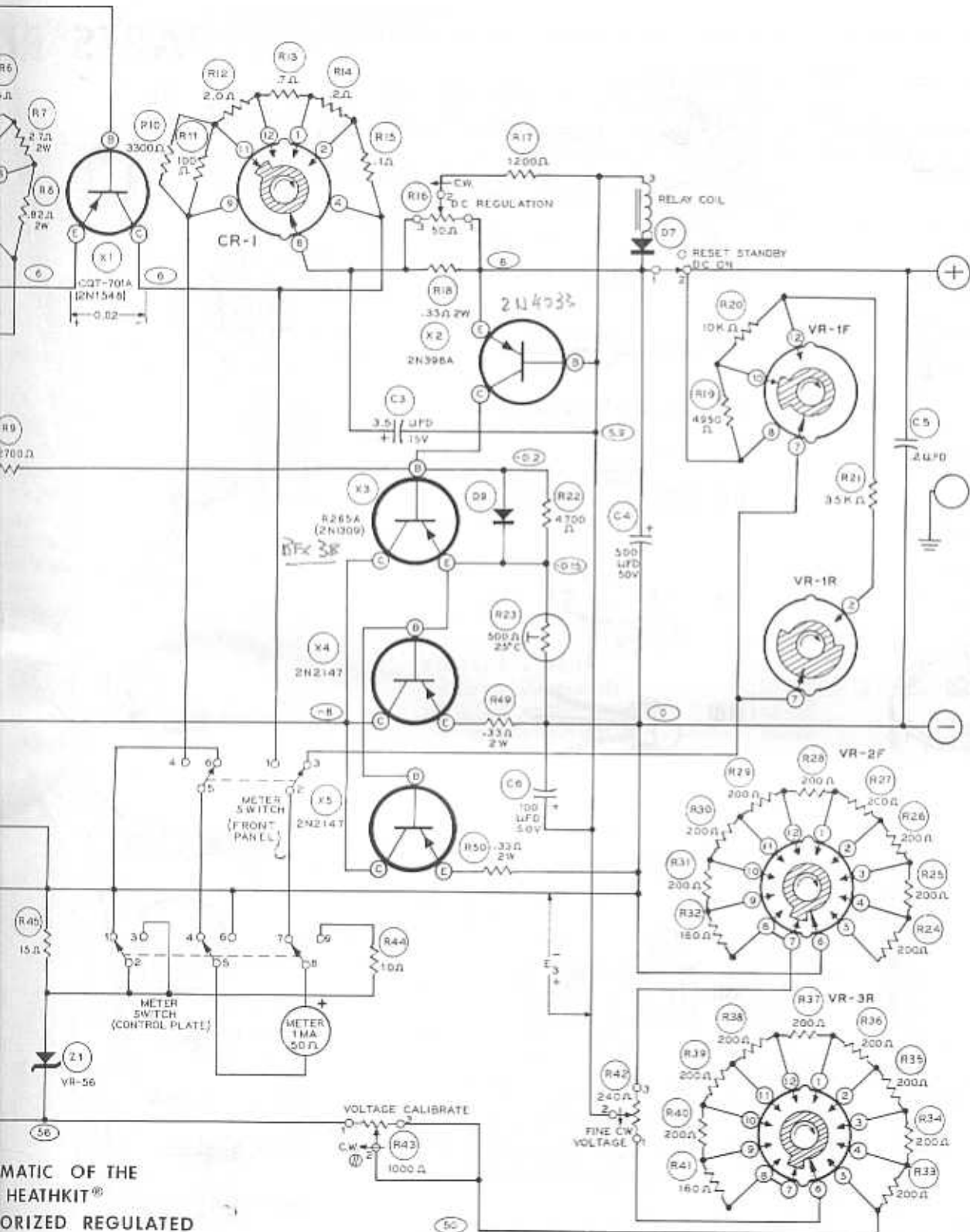

OMATIC OF THE
HEATHKIT®
ORIZED REGULATED
WER SUPPLY
ODEL IP-20

CHMS K - 1000.
ATT UNLESS OTHERWISE SPECIFIED.

PARTS PI

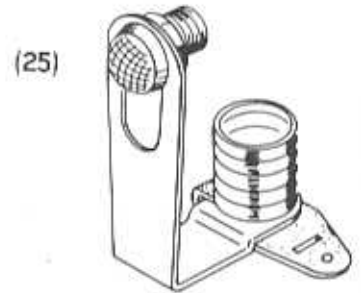
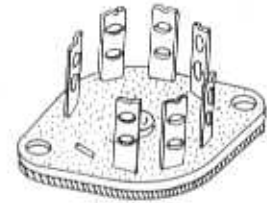
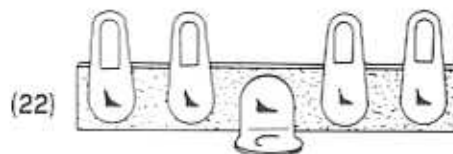
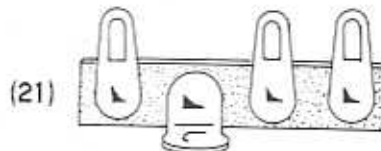
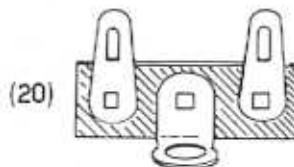
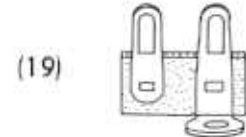
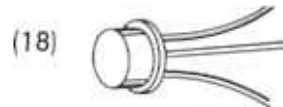
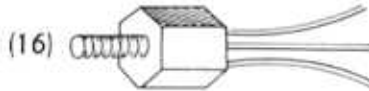
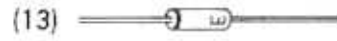
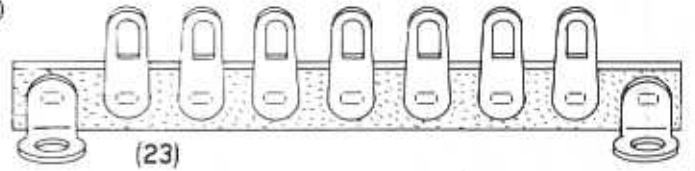
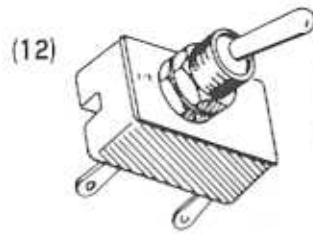
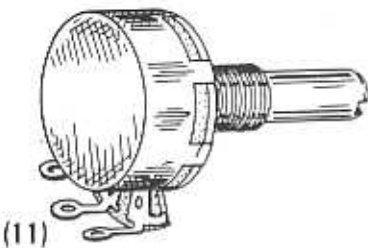
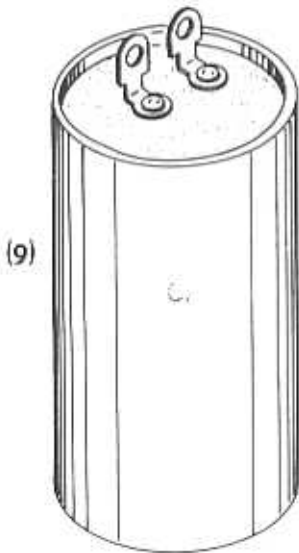
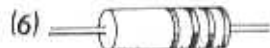
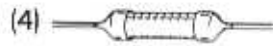

PARTS PICTORIAL

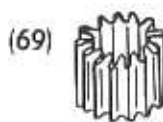
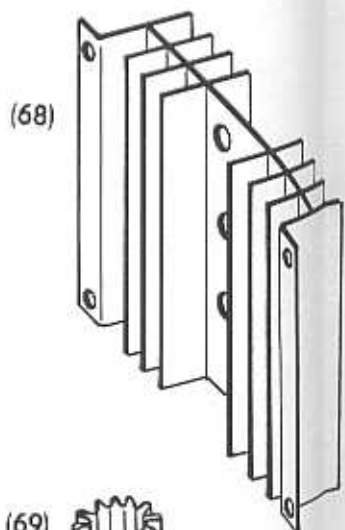
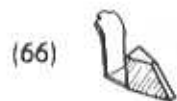
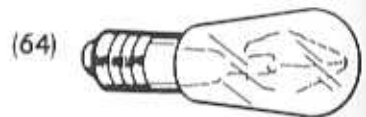
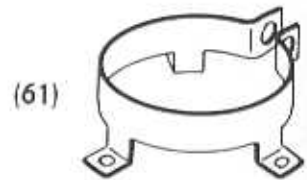
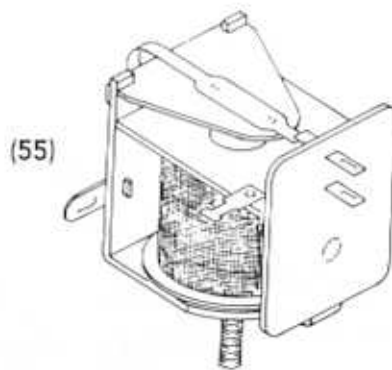
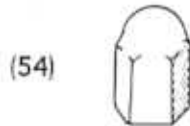
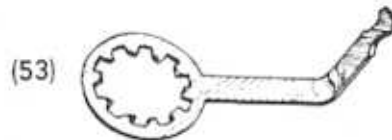
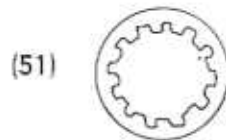
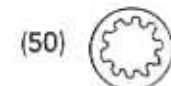
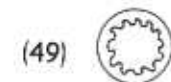
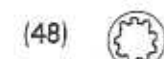
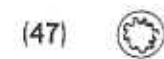
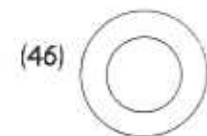
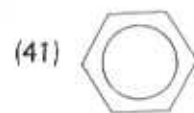
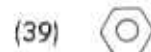
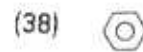
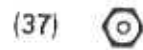

CONSTRUCTION NOTES

This manual is supplied to assist you in every way to complete your kit with the least possible chance for error. The arrangement shown is the result of extensive experimentation and trial. If followed carefully, the result will be highly stable and dependable performance. We suggest that you retain the manual in your files for future reference, both in the use of the equipment and for its maintenance.

UNPACK THE KIT CAREFULLY AND CHECK EACH PART AGAINST THE PARTS LIST. In so doing, you will become acquainted with the parts. Refer to the information on the inside covers of the manual to help you identify the components. If some shortage or parts damage is found in checking the Parts List, please read the Replacements section and supply the information called for therein. Include all inspection slips in your letter to us.

Resistors generally have a tolerance rating of 10% unless otherwise stated in the Parts List. Tolerances on capacitors are generally even greater. Limits of +100% and -20% are common for electrolytic capacitors.

We suggest that you do the following before work is started:

1. Lay out all parts so that they are readily available.
2. Provide yourself with good quality tools. Basic tool requirements consist of a screwdriver with a 1/4" blade; a small screwdriver with a 1/8" blade; long-nose pliers; wire cutters, preferably separate diagonal cutters; a penknife or a tool for stripping insulation from wires; a soldering iron (or gun) and rosin core solder. A set of nut drivers and a nut starter, while not necessary, will aid extensively in construction of the kit.

Most kit builders find it helpful to separate the various parts into convenient categories. Muffin tins or molded egg cartons make convenient trays for small parts. Resistors and capacitors may be placed with their lead ends inserted in the edge of a piece of corrugated cardboard until they are needed. Values can be written on the cardboard next to each component. The illustration shows one method that may be used.

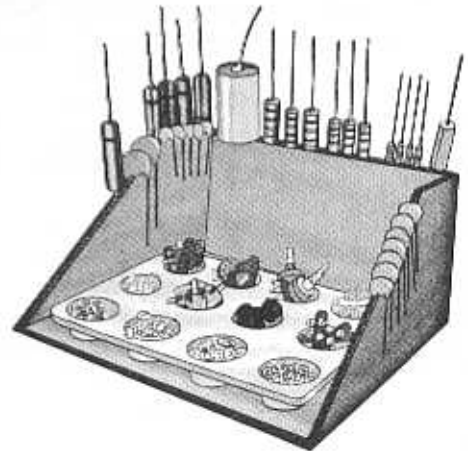

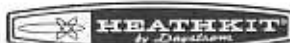

PARTS LIST

The numbers in parentheses in the Parts List are keyed to the numbers in the Parts Pictorial to aid in parts identification.

PART No.	PARTS Per Kit	DESCRIPTION	PART No.	PARTS Per Kit	DESCRIPTION
<u>Resistors</u>			<u>Capacitors</u>		
(1) 1-41	2	10 Ω 1/2 watt (brown-black-black)	(8) 25-129	1	3.5 μ fd 15 V tubular electrolytic
1-54	2	15 Ω 5% 1/2 watt (brown-green-black-gold)	25-56	1	100 μ fd 10 V tubular electrolytic
1-136	2	160 Ω 5% 1/2 watt (brown-blue-brown-gold)	25-128	1	100 μ fd 50 V tubular electrolytic
1-137	18	200 Ω 5% 1/2 watt (red-black-brown-gold)	25-70	1	100-40-40 μ fd electrolytic
1-80	1	1200 Ω 5% 1/2 watt (brown-red-red-gold)	25-131	1	250 μ fd 25 V tubular electrolytic
1-13	1	2700 Ω 1/2 watt (red-violet-red)	25-121	1	500 μ fd 50 V tubular electrolytic
1-122	1	3300 Ω 5% 1/2 watt (orange-orange-red-gold)	(9) 25-122	1	3000 μ fd 75 V tubular electrolytic
1-16	1	4700 Ω 1/2 watt (yellow-violet-red)	(10) 27-4	1	.2 μ fd mylar
(2) 1B-15	1	1000 Ω 2 watt (brown-black-red)	<u>Controls-Switches</u>		
1B-17	1	6800 Ω 2 watt (blue-gray-red)	(11) 11-47	1	30 Ω control
			11-21	1	50 Ω control
			11-45	1	240 Ω control
			11-44	2	1000 Ω control
			60-16	1	TPDT slide switch
			60-2	1	DPDT slide switch
			(12) 61-9	1	SPST toggle switch
			63-297	1	11-position rotary switch
			63-298	1	4-position rotary switch
<u>Precision Resistors</u>			<u>Transformer-Diodes-Transistors-Tube</u>		
(3) 2-94	1	.1 Ω 1%	54-123	1	Power transformer
2-130	1	.2 Ω 1%	(13) 56-8	1	Germanium diode
2-163	1	.7 Ω 1%	(14) 56-13	1	56 V zener diode (VR56)
(4) 2-159	1	100 Ω 1%	(15) 57-27*	1	Silicon diode (packed in bag)
2-165	1	4950 Ω 1%	57-29	7	Silicon diode
2-50	1	10 K Ω 1%	(16) 417-20	1	R265A transistor (2N1039)
2-166	1	35 K Ω 1%	(17) 417-42	1	CQT701A transistor (2N1548)
(5) 2A-2	1	2 Ω 1% 1 watt	(18) 417-43	1	2N398A transistor
(6) 3B-4	1	9.1 Ω 5% 2 watt (white-brown-gold-gold)	417-44	2	2N2147 transistor (matched pair)
3B-2	3	.33 Ω 5% 2 watt (orange-orange-silver-gold)	411-46	1	OB2 tube
3B-3	1	2.7 Ω 5% 2 watt (red-violet-gold-gold)			
3B-1	1	.82 Ω 5% 2 watt (gray-red-silver-gold)			
(7) 9-9	1	500 Ω thermistor			

*NOTE: The #57-27 silicon diode must not be interchanged with one of the other silicon diodes. Keep this diode in its bag until it is called for in assembly.

PART No.	PARTS Per Kit	DESCRIPTION	PART No.	PARTS Per Kit	DESCRIPTION
<u>Terminal Strips-Sockets-Knobs</u>			<u>Miscellaneous</u>		
(19)	431-14	1 - 2-lug terminal strip	(55)	69-13	1 - SPDT relay
(20)	431-2	1 - 2-lug terminal strip	(56)	73-2	1 - 3/4" grommet
(21)	431-3	1 - 3-lug terminal strip	(57)	73-3	3 - 1/2" grommet
(22)	431-5	1 - 4-lug terminal strip	(58)	75-17	6 - Bushing
(23)	431-35	2 - 7-lug terminal strip	(59)	75-24	1 - Strain relief
(24)	434-15	1 - 7-pin wafer socket	(60)	75-60	1 - Mica insulator
(25)	434-71	1 - Lamp socket	(61)	89-1	1 - Line cord
(26)	434-102	2 - Transistor socket		207-2	1 - Capacitor mounting clamp
(27)	434-117	3 - Transistor socket	(62)	211-15	1 - Black handle
(28)	462-139	4 - Knob		260-24	1 - Clip
<u>Hardware</u>			(63)	261-9	4 - Rubber feet
(29)	250-1	1 2-56 x 1/8" self-tapping screw		344-1	1 - Length hookup wire
(30)	250-175	4 2-56 x 3/8" screw		407-89	1 - Meter
(31)	250-49	6 3-48 x 1/4" screw	(64)	412-25	1 - 6 watt 120 V lamp (6S6)
(32)	250-89	25 6-32 x 3/8" screw		421-25	1 - 1-1/2 ampere slow-blow fuse
(33)	250-26	10 6-32 x 5/8" screw	(65)	423-2	1 - Fuse holder
(34)	250-137	4 8-32 x 3/8" screw	(66)	427-2	3 - Binding post base
(35)	250-92	1 8-32 x 5/8" screw	(66)	463-27	4 - Knob pointer
(36)	250-83	2 #10 x 1/2" sheet metal screw		481-3	1 - Capacitor mounting wafer
(37)	252-51	5 2-56 nut		331-6	1 - Solder
(38)	252-1	6 3-48 nut	(67)	100-M16B	2 - Manual
(39)	252-3	26 6-32 nut		100-M16R	1 - Black binding post cap
(40)	252-4	5 8-32 nut			1 - Red binding post cap
(41)	252-7	5 Control nut	<u>Sheet Metal</u>		
(42)	252-22	4 #6 speednut	200-M339	1 -	Chassis
(43)	253-1	4 #6 flat fiber washer	203-294F670-671-672		
(44)	253-2	3 #6 fiber shoulder washer		1 -	Front panel
(45)	253-9	4 #8 flat washer	205-M397	1 -	Rear chassis mounting plate
(46)	253-10	5 Control flat washer	205-M398F-850		
(47)	254-7	10 #3 lockwasher		1 -	Control mounting plate
(48)	254-1	36 #6 lockwasher	(68)	215-10	1 - Heat sink
(49)	254-2	5 #8 lockwasher	(69)	215-8	1 - Heat sink
(50)	254-4	2 Control lockwasher (large)		90-181	1 - Cabinet
(51)	254-5	2 Control lockwasher (small)			
(52)	259-1	4 #6 solder lug			
(53)	259-10	1 Control solder lug			
(54)	252-20	1 Control guard nut			

PROPER SOLDERING TECHNIQUES

Only a small percentage of customers find it necessary to return equipment for factory service. By far the largest portion of malfunctions in this equipment are due to poor or improper soldering.

If terminals are bright and clean and free of wax, frayed insulation and other foreign substances, no difficulty will be experienced in soldering. Correctly soldered connections are essential if the performance engineered into a kit is to be fully realized. If you are a beginner with no experience in soldering, a half hour's practice with some odd lengths of wire may be a worthwhile investment.

For most wiring, a 25 to 100 watt iron or its equivalent in a soldering gun is very satisfactory. A lower wattage iron than this may not heat the connection enough to flow the solder smoothly. Keep the iron tip clean by wiping it from time to time with a cloth.

CHASSIS WIRING AND SOLDERING

1. Unless otherwise indicated, all wire used is the type with colored insulation (hookup wire). In preparing a length of hookup wire, 1/4" of insulation should be removed from each end unless directed otherwise in the assembly step.
2. To avoid breaking internal connections when stripping insulation from the leads of transformers or similar components, care should be taken not to pull directly on the lead. Instead, hold the lead with pliers while it is being stripped.
3. Leads on resistors, capacitors, and similar components are generally much longer than need be to make the required connections. In these cases, the leads should be cut to proper length before the part is installed. In general, the leads should be just long enough to reach their terminating points.
4. Crimp or bend the lead (or leads) around the terminal to form a good joint without relying on solder for physical strength. If the lead is too large to allow bending or if the step states that it is not to be crimped, position it so that a good solder connection can still be made.
5. Position the work, if possible, so that gravity will help to keep the solder where you want it.
6. Then place the solder against the connection and it will immediately flow over the joint; use only enough solder to thoroughly wet the junction. It is usually not necessary to fill the entire hole in the terminal with solder.
7. Remove the solder and then the iron from the completed joint. Use care not to move the leads until the solder is solidified.

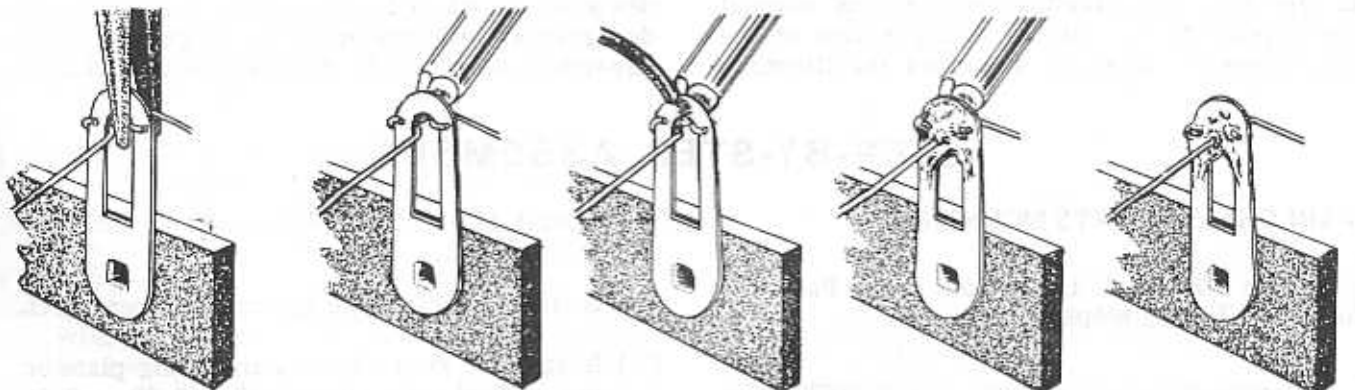

CRIMP WIRES HEAT CONNECTION APPLY SOLDER ALLOW SOLDER TO FLOW PROPER SOLDER CONNECTION

A poor or cold solder joint will usually look crystalline and have a grainy texture, or the solder will stand up in a blob and will not have adhered to the joint. Such joints should be reheated until the solder flows smoothly. In some cases, it may be necessary to add a little more solder to achieve a smooth, bright appearance.

ROSIN CORE SOLDER HAS BEEN SUPPLIED WITH THIS KIT. THIS TYPE OF SOLDER MUST BE USED FOR ALL SOLDERING IN THIS KIT. ALL GUARANTEES ARE VOIDED AND WE WILL NOT REPAIR OR SERVICE EQUIPMENT IN WHICH ACID CORE SOLDER OR PASTE FLUXES HAVE BEEN USED. IF ADDITIONAL SOLDER IS NEEDED, BE SURE TO PURCHASE ROSIN CORE (60:40 or 50:50 TIN-LEAD CONTENT) RADIO TYPE SOLDER.

STEP-BY-STEP PROCEDURE

The following instructions are presented in a logical step-by-step sequence to enable you to complete your kit with the least possible confusion. Be sure to read each step all the way through before beginning the specified operation. Also read several steps ahead of the actual step being performed. This will familiarize you with the relationship of the subsequent operations. When the step is completed, check it off in the space provided. This is particularly important as it may prevent errors or omissions, especially if your work is interrupted. Some kit builders have also found it helpful to mark each wire and part in colored pencil on the Pictorial as it is added.

ILLUSTRATIONS

The fold-out diagrams in this manual may be removed and attached to the wall above your working area; but because they are an integral part of the instructions, they should be returned to the manual after the kit is completed.

In general, the illustrations in this manual correspond to the actual configuration of the kit; however, in some instances the illustra-

tions may be slightly distorted to facilitate clearly showing all of the parts.

SOLDERING INFORMATION

The abbreviation "NS" indicates that a connection should not be soldered yet as other wires will be added. When the last wire is installed, the terminal should be soldered and the abbreviation "S" is used to indicate this. Note that a number will appear after each solder instruction. This number indicates the number of leads that are supposed to be connected to the terminal in point before it is soldered. For example, if the instruction reads, "Connect a wire to lug 1 (S-2)," it will be understood that there will be two wires connected to the terminal at the time it is soldered. (In cases where a wire passes through a terminal or lug and then connects to another point, it will count as two wires, one entering and one leaving the terminal.)

The steps directing the installation of resistors include color codes to help identify the parts. Also, if a part is identified by a letter-number designation (R1, C1, etc.) on the Schematic, its designation will appear at the beginning of the assembly step which directs its installation.

STEP-BY-STEP ASSEMBLY

MAIN CHASSIS PARTS MOUNTING

Refer to Pictorial 1 (fold-out from Page 13) for the following steps.

- () Locate the main chassis (#200-M339) and position it in front of you as shown in Pictorial 1.
- () Install 1/2" rubber grommets at locations H, K, and L.
- () Install a 3/4" rubber grommet at location D.
- () Mount the rear chassis mounting plate on the chassis as shown. Use 6-32 x 3/8" screws, #6 lockwashers, and 6-32 nuts. Note the location of the line cord hole.

- () Install a 6-32 speednut on each corner of the rear chassis mounting plate. Place the flat side of the speednut outward as shown.
- () Referring to Detail 1A, mount transistor sockets (#434-102) at locations X2 and X3. Use 2-56 x 3/8" screws, #3 lockwashers, and 2-56 nuts. Position lug 1 of each socket as shown by the arrows in Pictorial 1.
- () Mount the wafer tube socket at location V1. Use 3-48 x 1/4" screws, #3 lockwashers, and 3-48 nuts. Position the blank space as shown by the arrow.
- () Install the clip (#260-24) at location F. Use a 2-56 x 1/8" screw and a 2-56 nut. Refer to Detail 1B.

NOTE: When mounting terminal strips, place a #6 lockwasher between each mounting foot and the chassis, and one under each nut.

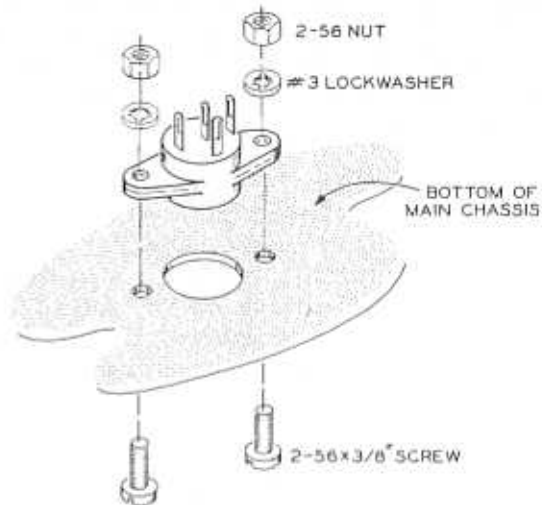

Detail 1A

- () C10, C9, C8. Refer to Detail 1D and mount the 100-40-40 μ f electrolytic capacitor (#25-70) at location C. Secure the capacitor by twisting each mounting tab 1/8 turn with long-nose pliers. Position the capacitor lug markings as shown.

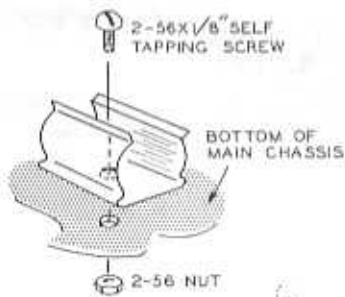

Detail 1B

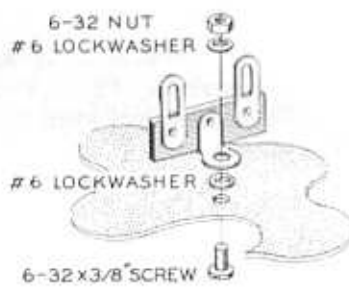

Detail 1C

- () Referring to Detail 1C, mount a 2-lug terminal strip at location N. Use a 6-32 x 3/8" screw, #6 lockwashers, and a 6-32 nut.
- () Mount a 4-lug terminal strip at location M. Use a 6-32 x 3/8" screw, #6 lockwashers, and a 6-32 nut.
- () Mount 7-lug terminal strips at locations E and G. Use 6-32 x 3/8" screws, #6 lockwashers, and 6-32 nuts.
- () Refer to Detail 1D and mount the electrolytic capacitor mounting wafer at location C with a 3-lug terminal strip on one mounting screw at location B. Use 6-32 x 3/8" screws, #6 lockwashers, and 6-32 nuts. The wafer goes on the side of the chassis opposite the terminal strip.

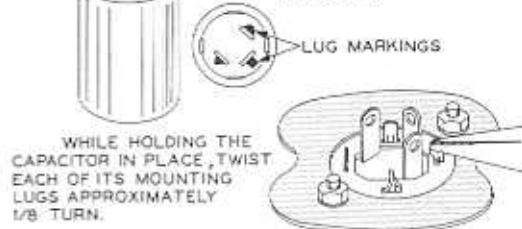
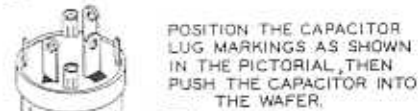
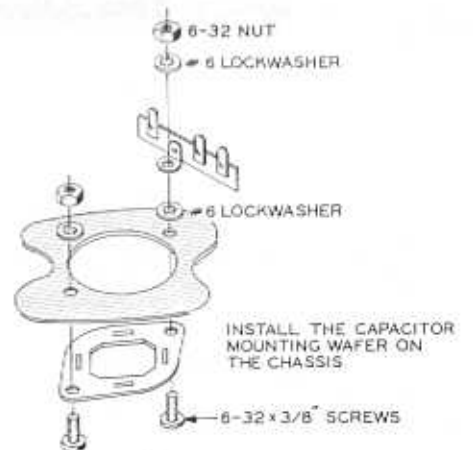

Detail 1D

- () Referring to Detail 1E, mount the electrolytic capacitor mounting clamp (#207-2) at location P. Use 6-32 x 3/8" screws, #6 lockwashers, and 6-32 nuts. Do not tighten the screws.
- () C2. Refer to Detail 1E and install the 3000 μ fd 75 V electrolytic capacitor in the mounting clamp. Position the capacitor lugs as shown in Pictorial 1. Secure it with an 8-32 x 5/8" screw, #8 lockwasher, and an 8-32 nut in the clamp as shown. Do not over-tighten this screw or you will damage the capacitor. Now tighten the three mounting screws.
- () Mount the relay (#69-13) at location J. Use two flat fiber washers, a fiber shoulder washer, #6 lockwasher, and a 6-32 nut as shown in Detail 1F.

Set this assembly aside until it is called for later.

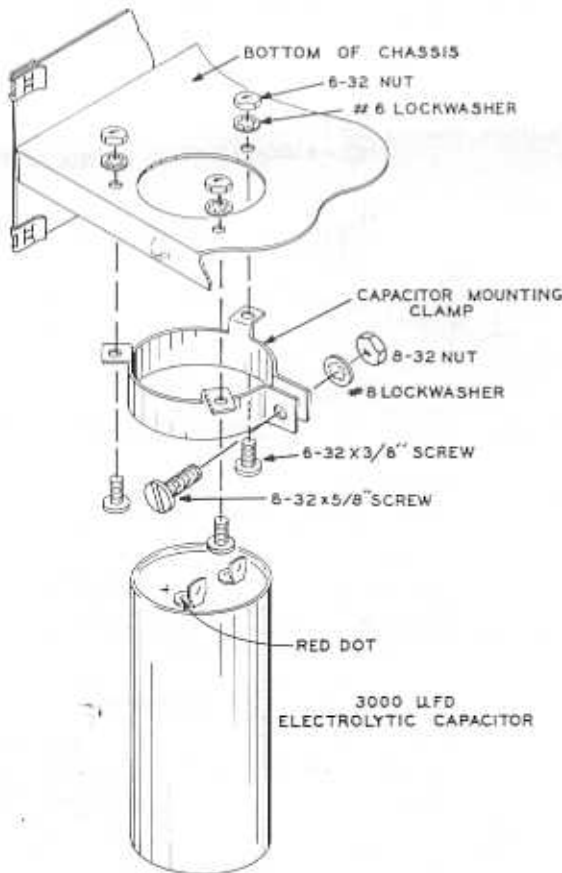

Detail 1E

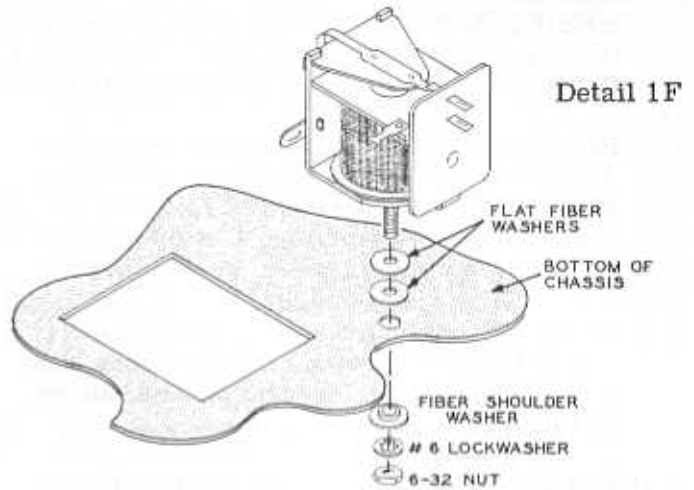

Detail 1F

CONTROL PLATE PARTS MOUNTING-WIRING

Refer to Pictorial 2 for the following steps.

- () Locate the control mounting plate (#205-M398F-850) and position it as shown.
- () R43, R47. Mount the 1 K Ω controls (#11-44) at locations Q and R. Use 3-48 x 1/4" screws, #3 lockwashers, and 3-48 nuts as shown in Detail 2A. Position the control lugs as shown in Pictorial 2. Bend the lugs up slightly.
- () Mount the TPDT slide switch (#60-16) at location S. Use 6-32 x 3/8" screws.
- () Remove 1" of insulation from one end and 1/4" of insulation from the other end of a 3" wire. Connect the 1" stripped end to lug 2 of control Q (S-1). Wrap it once around lug 3 of Q (NS). Connect the other end to lug 1 of control R (S-1).

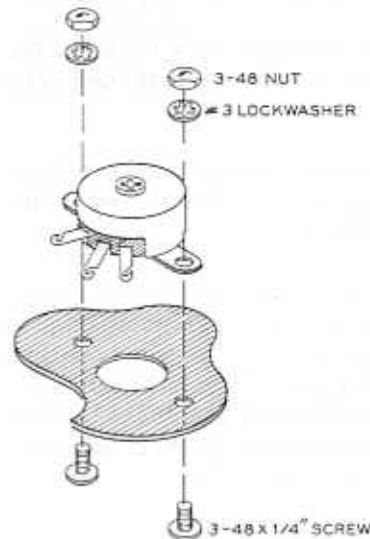

Detail 2A

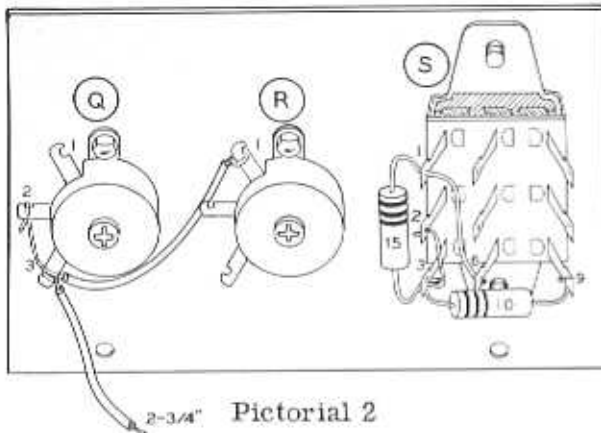

2-3/4" Pictorial 2

- () Connect a 2-3/4" wire to lug 3 of control Q (S-3). Leave the other end free.
- () R44. Connect one lead of a 10 Ω (brown-black-black) resistor to lug 9 of switch S (S-1). Run the other lead through lug 3 (NS) up to lug 2 (S-1) of switch S.
- () R45. Place one lead of a 15 Ω (brown-green-black) resistor through lug 1 (NS) to lug 6 (NS) of switch S. Now solder lug 1 of S (S-2). Connect the other lead of this resistor to lug 3 of switch S (NS).

Set this assembly aside until it is called for later.

Refer to Pictorial 3 and Detail 3A for the following steps.

- () Locate the transistor heat sink (#215-10) and position it as shown. See Detail 3A.
- () X1. Mount a CQT701 transistor at X1. Use two 6-32 x 5/8" screws, #6 lockwashers, a mica insulator, and a transistor socket (#434-117). Note that the socket is on one side of the heat sink and the transistor on the other side. See Detail 3A.
- () X4. Mount the 2N2147 transistor at location X4. Use two 6-32 x 5/8" screws, #6 lockwashers, and a transistor socket. A mica insulator is not used with this transistor.

- () X5. Mount a 2N2147 transistor and 2-lug terminal strip at T at location X5. Use 6-32 x 5/8" screws, #6 lockwashers, and a 6-32 nut.
- () Connect one end of a 4-1/2" wire to lug 1 of terminal strip T (NS). Leave the other end free.
- () Connect one end of a 7" wire to lug 1 of terminal strip T (NS). Leave the other end free.
- () Connect a 1-3/4" wire from lug 1 of terminal strip T (S-3) to lug C of transistor X4 (S-1).
- () Connect a 2" wire from lug B of transistor X5 (NS) to lug B of transistor X4 (S-1).
- () Connect one end of a 8-1/2" wire to lug 2 of terminal strip T (NS). Leave the other end free.
- () Remove 1-1/4" of insulation from one end and 1/4" of insulation from the other end of a 4-3/4" wire. Connect the 1/4" stripped end to lug B of transistor X5 (NS). Leave the other end free.
- () Strip 1/4" of insulation from only one end of a 6-1/2" wire and connect this end to lug B of transistor X1 (S-1).
- () R49. Connect a .33 Ω (orange-orange-silver-gold) 2 watt resistor from lug E of transistor X4 (S-1) to lug 2 of terminal strip T (NS).
- () R50. Connect a .33 Ω (orange-orange-silver-gold) 2 watt resistor from lug E of transistor socket X5 (S-1) to lug 2 of terminal strip T (NS).
- () R23. Position the body of the 500 Ω thermistor down to the bottom of the indicated hole in transistor socket X5. Separate the leads; connect one lead to lug 2 of terminal strip T (S-4) and the other lead to lug B of transistor X5 (S-3). Make sure that the body of the thermistor is in contact with the bottom of the hole.

6-32 x
SCRE

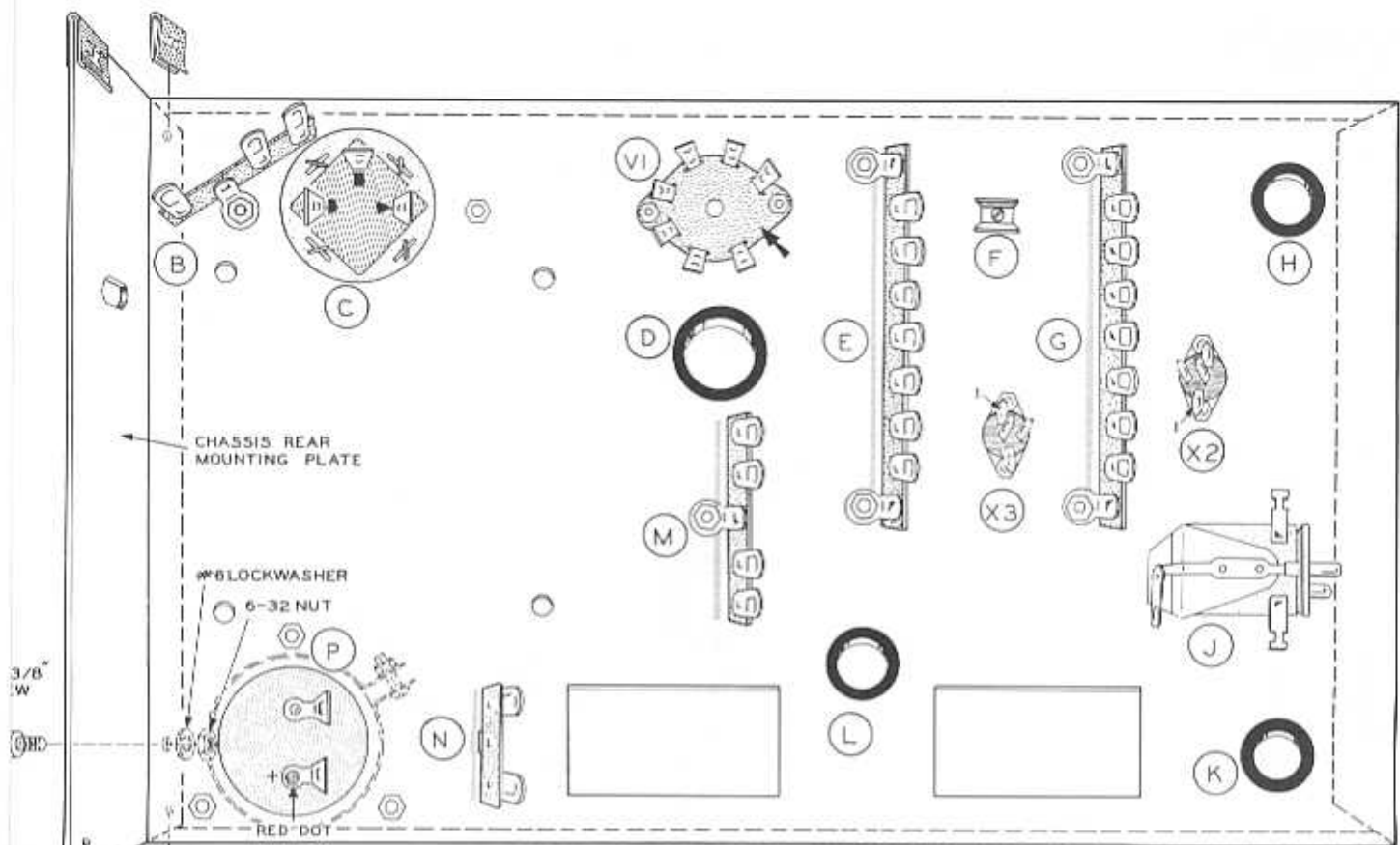

Pictorial 1

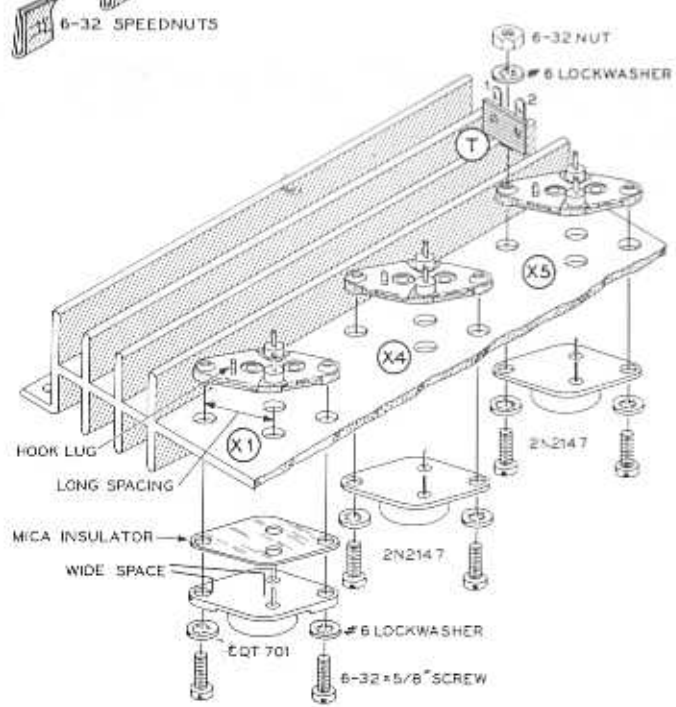

Detail 3A

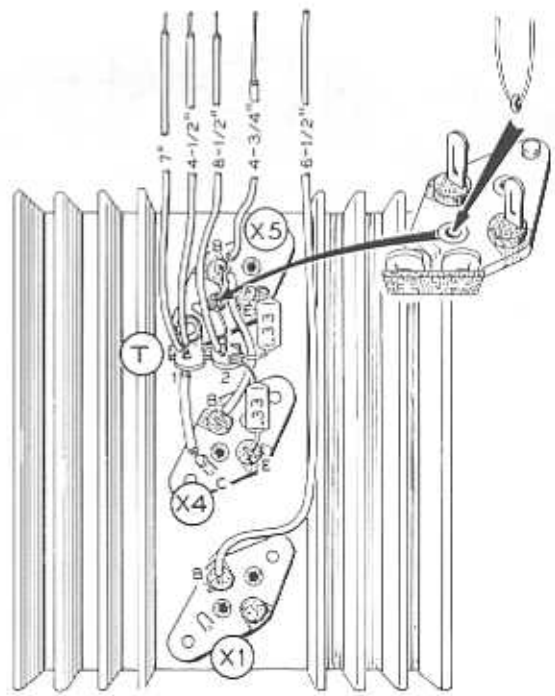

Pictorial 3

Set this assembly aside until it is called for later.

VOLTAGE RANGE SWITCH WIRING

Refer to Pictorial 4A for the following steps.

NOTE: In the following steps, all wires and components will be connected to lugs on the first wafer of the 11-position rotary switch (#63-297). All resistors called for in this manual are 1/2 watt unless otherwise specified in the steps.

Detail 4A

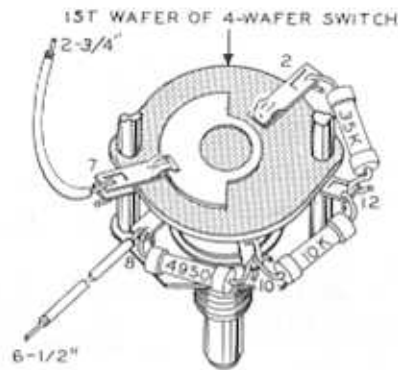

CONNECT A

() R21, 35 K Ω
(1% precision)

FROM LUG

2 (S-1)

TO LUG

12 (NS).

() R20, 10 K Ω
(1% precision)

12 (S-2)

10 (NS).

() R19, 4950 Ω
(1% precision)

10 (S-2)

8 (NS).

() 6-1/2" wire

8 (S-2)

not connected.

() 2-3/4" wire

7 (S-1)
solder both lugs.

not connected.

Refer to Pictorial 4B for the following steps.

NOTE: In the following steps, all wires and components will be connected to the lugs on the second wafer of the 11-position rotary switch.

Detail 4B

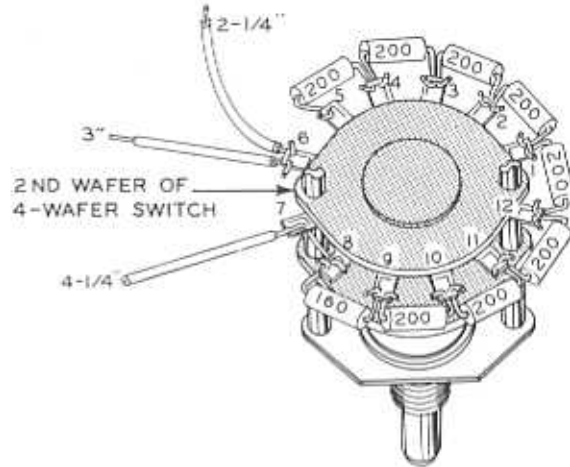

<u>CONNECT A</u>	<u>FROM LUG</u>	<u>TO LUG</u>
() 4-1/4" wire (strip one end only).	through lug 7 (S-2) to lug 8 (NS)	not connected.
() R32, 160 Ω (brown-blue-brown)	8 (S-2)	9 (NS).
() R31, 200 Ω (red-black-brown)	9 (S-2)	10 (NS).
() R30, 200 Ω (red-black-brown)	10 (S-2)	11 (NS).
() R29, 200 Ω (red-black-brown)	11 (S-2)	12 (NS).
() R28, 200 Ω (red-black-brown)	12 (S-2)	1 (NS).
() R27, 200 Ω (red-black-brown)	1 (S-2)	2 (NS).
() R26, 200 Ω (red-black-brown)	2 (S-2)	3 (NS).
() R25, 200 Ω (red-black-brown)	3 (S-2)	4 (NS).
() R24, 200 Ω (red-black-brown)	4 (S-2)	5 (S-1).
() 2-1/4" wire	6 (NS)	not connected.
() 3" wire	6 (S-2)	not connected.

Refer to Pictorial 4C for the following steps.

NOTE: In the following steps, all wires and components will be connected to the lugs on the third wafer of the 11-position rotary switch.

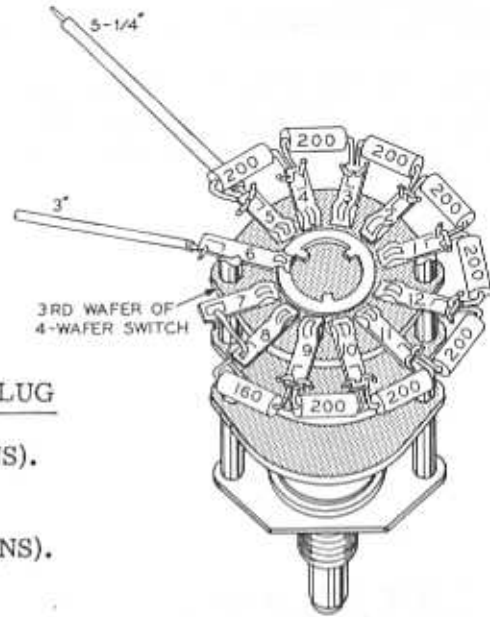

Detail 4C

<u>CONNECT A</u>	<u>FROM LUG</u>	<u>TO LUG</u>
() R41, 160 Ω (brown-blue-brown)	through lug 8 (S-2) to lug 7 (S-1)	9 (NS).
() R40, 200 Ω (red-black-brown)	9 (S-2)	10 (NS).
() R39, 200 Ω (red-black-brown)	10 (S-2)	11 (NS).
() R38, 200 Ω (red-black-brown)	11 (S-2)	12 (NS).
() R37, 200 Ω (red-black-brown)	12 (S-2)	1 (NS).
() R36, 200 Ω (red-black-brown)	1 (S-2)	2 (NS).
() R35, 200 Ω (red-black-brown)	2 (S-2)	3 (NS).
() R34, 200 Ω (red-black-brown)	3 (S-2)	4 (NS).
() R33, 200 Ω (red-black-brown)	4 (S-2)	5 (NS).
() 5-1/4" wire (strip 3/4" from free end)	5 (S-2)	not connected.
() 3" wire (strip one end only)	6 (S-1)	not connected
() Referring to Pictorial 4D, connect one end of a 10" wire to both lugs 7 of the fourth wafer of the 11-position switch (S-1). Set this assembly aside until called for later.		

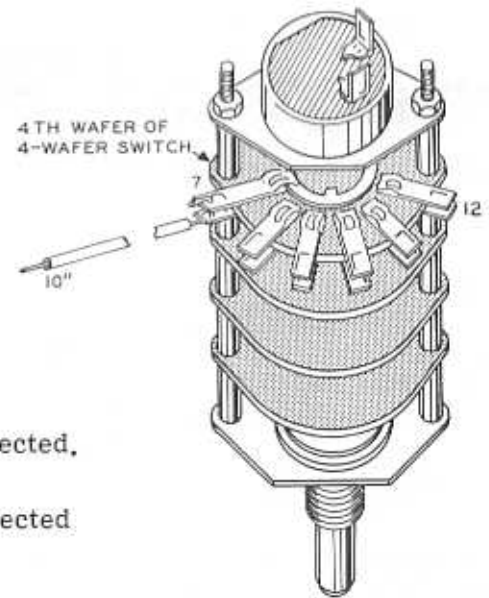

Detail 4D

CURRENT RANGE SWITCH WIRING

Refer to Pictorial 5A for the following steps.

NOTE: In the following steps, all wires and components will be connected to lugs on the first wafer of the 4-position rotary switch (#63-298).

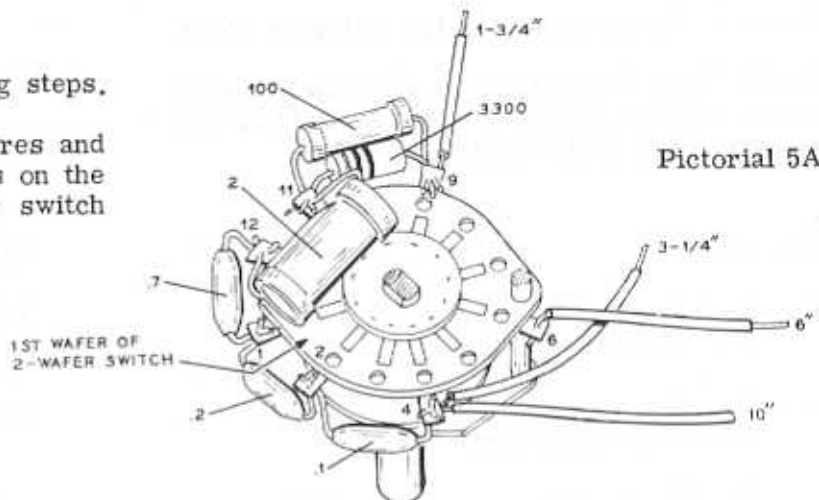

<u>CONNECT A</u>	<u>FROM LUG</u>	<u>TO LUG</u>
() R10, 3300 Ω (orange-orange-red)	9 (NS)	11 (NS).
() R11, 100 Ω (precision)	9 (NS)	11 (NS).
() 1-3/4" wire	9 (S-3)	not connected.
() R12, 2 Ω (precision)	11 (S-3)	12 (NS).
() R13, .7 Ω (precision)	12 (S-2)	1 (NS).
() R14, .2 Ω (precision)	1 (S-2)	2 (NS).
() R15, .1 Ω (precision)	2 (S-2)	4 (NS).
() 10" wire (strip one end only)	4 (NS)	not connected.
() 3-1/4" wire	4 (S-3)	not connected.
() 6" wire	6 (S-1)	not connected.

Refer to Pictorial 5B for the following steps.

NOTE: In the following steps, all components and wires will be connected to the second wafer of the 4-position rotary switch.

<u>CONNECT A</u>	<u>FROM LUG</u>	<u>TO LUG</u>
() R6, 15 Ω (brown-green-black)	1 (S-1)	2 (NS).
() R7, 2.7 Ω 2 watt (red-violet-gold-gold)	2 (S-2)	3 (NS).
() R8, .82 Ω 2 watt (gray-red-silver-gold)	3 (S-2)	5 (NS).
() 3-1/4" wire (strip one end only)	5 (S-2)	not connected.
() R4, 9.1 Ω 2 watt (white-brown-gold)	6 (NS)	9 (NS).
() 9" wire	6 (S-2)	not connected.
() R5, 10 Ω (brown-black-black)	9 (NS)	11 (S-1).
() 3-1/2" wire	9 (S-3)	not connected.

Set this assembly aside until called for later.

INITIAL WIRING ON MAIN CHASSIS

Refer to Pictorial 6 (fold-out from Page 14) for the following steps.

- () Refer to Detail 6A and mount the control plate subassembly on the side of the main chassis. Use 6-32 x 3/8" screws, #6 lockwashers, and 6-32 nuts.
- () Refer to Detail 6A and mount the transistor heat sink assembly on the top side of the main chassis. Use 6-32 x 3/8" screws, #6 fiber shoulder washers, #6 fiber flat wash-

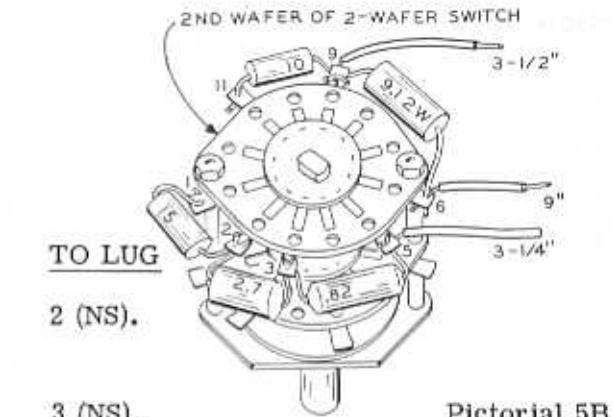

ers, #6 lockwashers and 6-32 nuts. Be sure to position transistor X1 (CQT701) as shown. Place all wires from the subassembly through grommet L. Make sure the heat sink clears the chassis at all places.

NOTE: The following steps concern the free ends of the wires extending through grommet L from the transistors on the heat sink.

- () Route the longest wire (from lug 2 of terminal strip T) as shown in Pictorial 6 and leave it free.

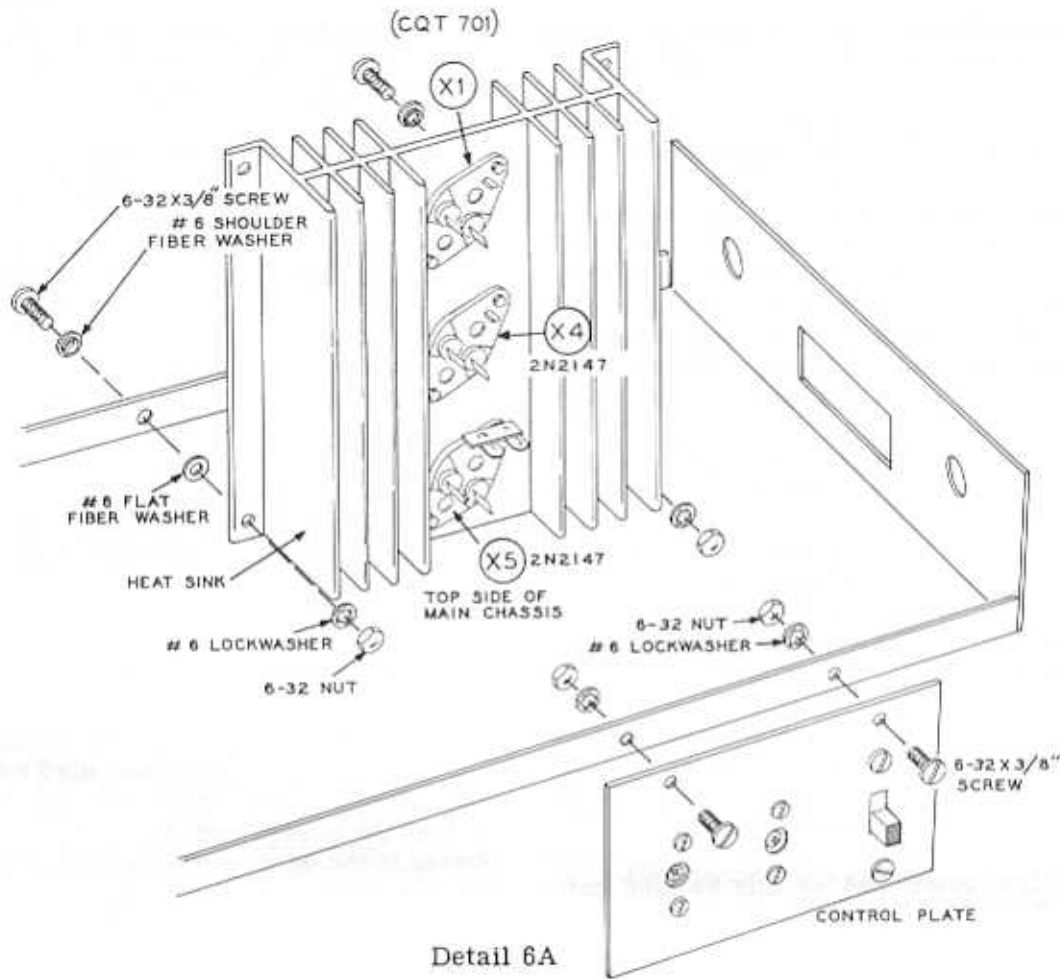

Detail 6A

- () Connect the next longest stripped wire (from lug 1 of terminal strip T) to lug 1 of electrolytic capacitor P (NS).
- () Locate the wire stripped 1-1/4" (from lug B of X5). Run it through lug 5 of terminal strip E (NS), and then over to lug 1 of transistor socket X3 (S-1).
- () Strip 1/4" of insulation from the unstripped wire (from lug B of X1) and connect it to lug 3 of terminal strip M (NS).
- () Connect the remaining wire (from lug 1 of terminal strip T) to lug 3 of transistor socket X3 (S-1).
- () Cut the following lengths of hookup wire and strip 1/4" of insulation from each end. These wires are listed in the order that they will be used in the following steps.
 - 5"
 - 3-3/4"
 - 4"
 - 2-3/4"
 - 1-1/2"
- () Connect a 5" wire from lug 2 of electrolytic capacitor P (NS) to lug 4 of terminal strip M (NS).

- () Connect a 3-3/4" wire from lug 4 of terminal strip M (NS) to lug 2 of relay J (S-1).
- () Connect a 4" wire from lug 3 of relay J (S-1) to lug 5 of terminal strip G (NS).
- () Strip an additional 1-1/4" of insulation from one end of the 2-3/4" wire. Pass this end through lug 6 of terminal strip G (NS), through lugs 2 and 4 of transistor socket X3 (solder both lugs), and over to lug 6 of terminal strip E (NS). Connect the other end to lug 3 of transistor socket X2 (S-1).
- () Connect a 1-1/2" wire from lug 6 of switch S (S-2) to lug 2 of terminal strip G (NS).
- () Cut two 9" wires and strip 1/4" of insulation from both ends of only one wire. Leave the other unstripped. Twist these two wires together so that there are approximately 3 turns per inch.
- () At either end of this twisted pair, connect the stripped wire to lug 5 of switch S (S-1). Strip 1/4" of insulation from the other wire and connect it to lug 8 of S (S-1).
- () Place the other end of this twisted pair through grommet H. It will be connected later.
- () Cut two 6-1/2" wires and strip 1/4" of insulation from only one of these wires. Twist these two wires together with approximately 3 turns per inch.
- () At either end of this twisted pair, connect the stripped lead to lug 4 of switch S (S-1). Strip 1/4" of insulation from the other wire and connect it to lug 7 of switch S (S-1).
- () Place the other end of this twisted pair through grommet H. It will be connected later.
- () Cut the following lengths of hookup wire and strip 1/4" of insulation from each end. These wires are listed in the order that they will be used in the following steps.

4-1/2"	5"
2"	12-1/2"
3-1/2"	

- () Connect a 4-1/2" wire from lug 1 of terminal strip E (NS) to lug 3 of electrolytic capacitor C (S-1).
- () Connect a 2" wire from lug 2 of terminal strip E (NS) to lug 7 of tube socket V1 (NS).
- () Connect a 3-1/2" wire from lug 7 of tube socket V1 (S-2) to lug 4 of electrolytic capacitor C (S-1).
- () Connect a 5" wire from lug 1 of control Q (NS) to lug 2 of electrolytic capacitor C (S-1).
- () Connect one end of a 12-1/2" wire to lug 3 of terminal strip B (NS). Place the other end of this wire through grommet D. It will be connected later.
- () Cut a 15-1/2" and a 19" length of wire and strip 1/4" of insulation from the ends of each wire. Place the two wires together so that they are even at one end. Twist these wires together with approximately 3 turns per inch.
- () At the uneven end of this twisted pair, connect the shorter wire to lug 1 of tube socket V1 (S-1) and the long wire to lug 1 of electrolytic capacitor C (NS).
- () Place the other end of this twisted pair through grommet K. It will be connected later.
- () D8. Locate the #57-27 diode which is packed in an individual bag. Refer to Detail 6B to determine the polarity. Then connect the cathode (K) lead to lug 1 of electrolytic capacitor C (S-2). Connect the other lead to lug 1 of terminal strip B (NS).

NOTE: WHEN INSTALLING SILICON DIODES, THE CATHODE END SHOULD BE PLACED AS DIRECTED. THE CATHODE END IS MARKED WITH EITHER COLOR END, COLOR DOT, OR COLOR BAND. IN THE ILLUSTRATION, THE SYMBOL K INDICATES THE CATHODE END.

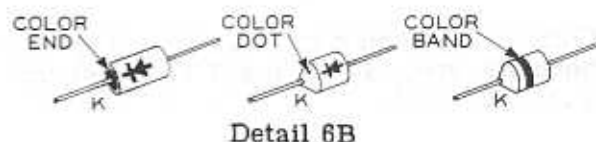

- () R48. Connect the 1000 Ω (brown-black-red) 2 watt resistor from lug 1 of control Q (S-2) to lug 5 of tube socket V1 (S-1).

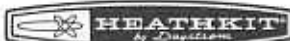

- () Z1. Locate the 56 volt zener diode (#56-13, VR56) and place it in the clip as shown in Pictorial 6. Be sure that it is positioned as shown and setting flat on the bottom of the clip.
 - () Connect the (+) lead (cathode) of the zener diode to lug 1 of terminal strip E (NS). Place the other lead of the diode through lug 1 of terminal strip G (NS) up to lug 3 of switch S (S-4). Now solder lug 1 of G (S-2).
 - () Connect the lead extending from lug 3 of control Q to lug 1 of terminal strip E (S-3).
 - () C7. Connect the positive (+) lead of a 100 μ fd 10 V electrolytic capacitor to lug 2 of terminal strip G (NS). Pass the other lead of this capacitor through lug 3 of terminal strip E (NS) and connect it to lug 2 of terminal strip E (NS).
 - () R46. Connect a 200 Ω (red-black-brown) resistor from lug 2 of terminal strip G (NS) to lug 2 of terminal strip E (S-3).
 - () R9. Connect one lead of a 2700 Ω (red-violet-red) resistor to lug 3 of terminal strip E (S-3). Connect the other lead of this resistor to lug 6 of E (S-2).
 - () D9. Connect the germanium diode (clear body) from lug 5 of terminal strip E (NS) to lug 6 of terminal strip G (NS). The cathode (K) lead from the color band end must go to terminal strip E.
 - () R22. Connect a 4700 Ω (yellow-violet-red) resistor from lug 5 of terminal strip E (S-4) to lug 6 of terminal strip G (S-4).
 - () C3. Connect the positive (+) lead of a 3.5 μ fd electrolytic capacitor to lug 3 (NS) and the other lead to lug 5 (NS) of terminal strip G.
 - () R17. Connect a 1200 Ω (brown-red-red) resistor from lug 5 (NS) to lug 4 (NS) of terminal strip G.
 - () D7. Place the cathode (K) lead of a silicon diode (#57-29) (one of seven) through lug 7 of terminal strip G (NS) over to lug 1 of transistor socket X2 (S-1). Connect the other lead to lug 1 of relay J (S-1).
 - () D5. Connect the cathode (K) lead of a silicon diode (#57-29) to lug 2 (NS) and the other lead to lug 1 (NS) of terminal strip M.
 - () C1. Connect the positive (+) lead of a 250 μ fd 25 V electrolytic capacitor to lug 4 (S-3) and the other lead to lug 1 (NS) of terminal strip M.
 - () R1. Connect a 200 Ω (red-black-brown) resistor between lugs 1 (S-3) and 3 (NS) of terminal strip M.
 - () D6. Connect the cathode (K) lead of a silicon diode (#57-29) to lug 3 of terminal strip M (S-3) and the other lead to lug 7 of terminal strip E (NS).
 - () R3. Connect a 6800 Ω (blue-gray-red) 2 watt resistor between lugs 1 (NS) and 2 (NS) of electrolytic capacitor P.
- NOTE: In the following steps, position the diodes as shown in Pictorial 6. Refer to Detail 6B to determine the polarity.
- () D3. Connect the cathode (K) lead of a silicon diode (#57-29) to lug 1 of terminal strip N (NS) and the other lead to lug 1 of electrolytic capacitor P (NS).
 - () D2. Connect the cathode (K) lead of a silicon diode (#57-29) to lug 2 of electrolytic capacitor P (NS) and the other lead to lug 1 of terminal strip N (NS).
 - () D4. connect the cathode (K) lead of a silicon diode (#57-29) to lug 2 of terminal strip N (NS) and the other lead to lug 1 of electrolytic capacitor P (S-4).
 - () D1. Connect the cathode (K) lead of a silicon diode (#57-29) to lug 2 of electrolytic capacitor P (NS) and the other lead to lug 2 of terminal strip N (NS).

This completes the Initial Wiring on the main chassis. Set this assembly aside until it is called for later.

Refer to Pictorial 7 for the following steps.

- () Locate the front panel and position it as shown. Place a cloth on your work area to protect the panel finish.
- () Refer to Detail 7A and mount the three binding posts at locations FG, FH, and FJ. Use two solder lugs on FH and one each on FG and FJ. Position the solder lugs as shown in Pictorial 7. Point lug FJ to the hole at FK. Position the holes in the binding post bases parallel to the bottom edge of the front panel.

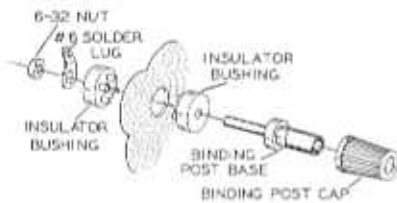

Detail 7A

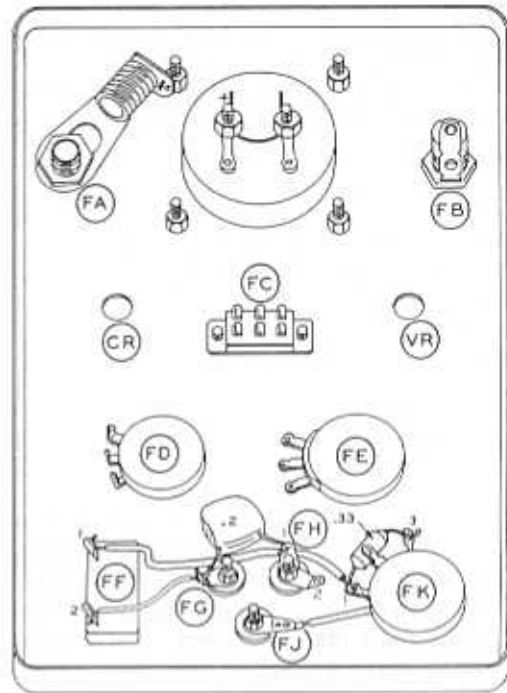

Pictorial 7

- () R16. Place a control solder lug on the bushing of the 50 Ω control (#11-21) and straighten out the solder lug. Mount this control at location FK. Use a control flat washer and a control nut. See Detail 7B. Position the control lugs as shown. Make sure that the solder lug touches the lug on FJ.

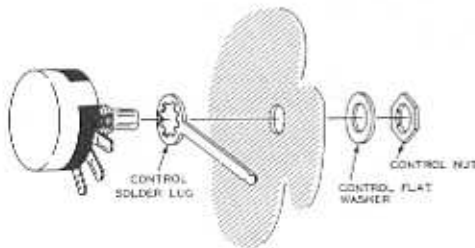

Detail 7B

- () R2. Mount the 30 Ω control (#11-47) at location FD. Use a large control lockwasher, control flat washer, and a control nut. Position the control lugs as shown.
- () Refer to Detail 7C and mount the SPST toggle switch (#61-9) at location FF. Use the hardware supplied with the switch for mounting. Space the switch, using the spacing nut as shown. Position the switch lugs as shown in Pictorial 7.

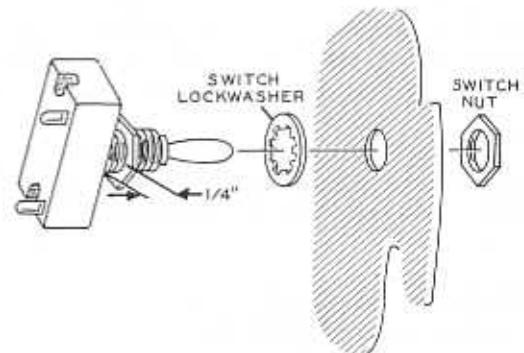

Detail 7C

- () R42. Mount the 240 Ω control (#11-45) at location FE. Use a large control lockwasher, a control flat washer, and a control nut. Position the control lugs as shown.

- () Mount the DPDT slide switch (#60-2) at location FC. Use two 6-32 x 3/8" screws.
- () Refer to Detail 7D and mount the fuse holder at location FB. Use the hardware supplied with the holder. Position the lugs as shown in Pictorial 7.

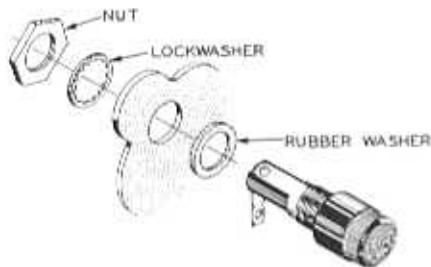

Detail 7D

- () Refer to Detail 7E and mount the lamp socket assembly at location FA. Position the socket as shown in Pictorial 7.

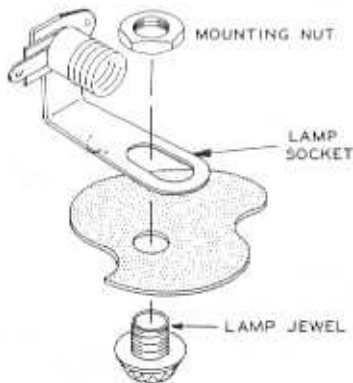

Detail 7E

- () Locate the meter and carefully remove it from its box. Refer to Detail 7F and mount the meter on the front panel as shown. Use the hardware supplied with the meter. Be careful not to overtighten the hardware as you may damage the meter.

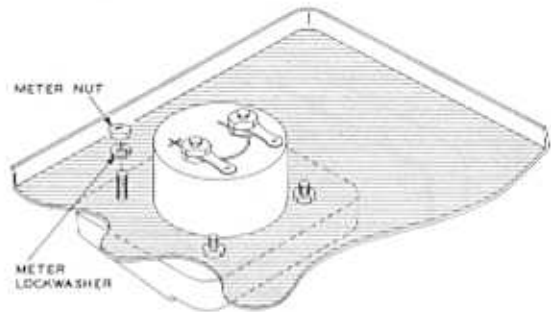

Detail 7F

- () Connect a 5" wire from lug 1 of switch FF (NS) to lug 1 of control FK (NS).
- () Connect a 3" wire from lug 2 of switch FF (S-1) to binding post FG (NS).
- () R18. Connect a .33 Ω (orange-orange-silver-gold) 2 watt 5% resistor between lugs 1 (S-2) and 3 (NS) of control FK.
- () C5. Connect a .2 μ fd mylar capacitor from binding post FG (NS) to solder lug 1 on binding post FH (NS).
- () Solder the control solder lug mounted on control FK to the solder lug on binding post base FJ (S-1).

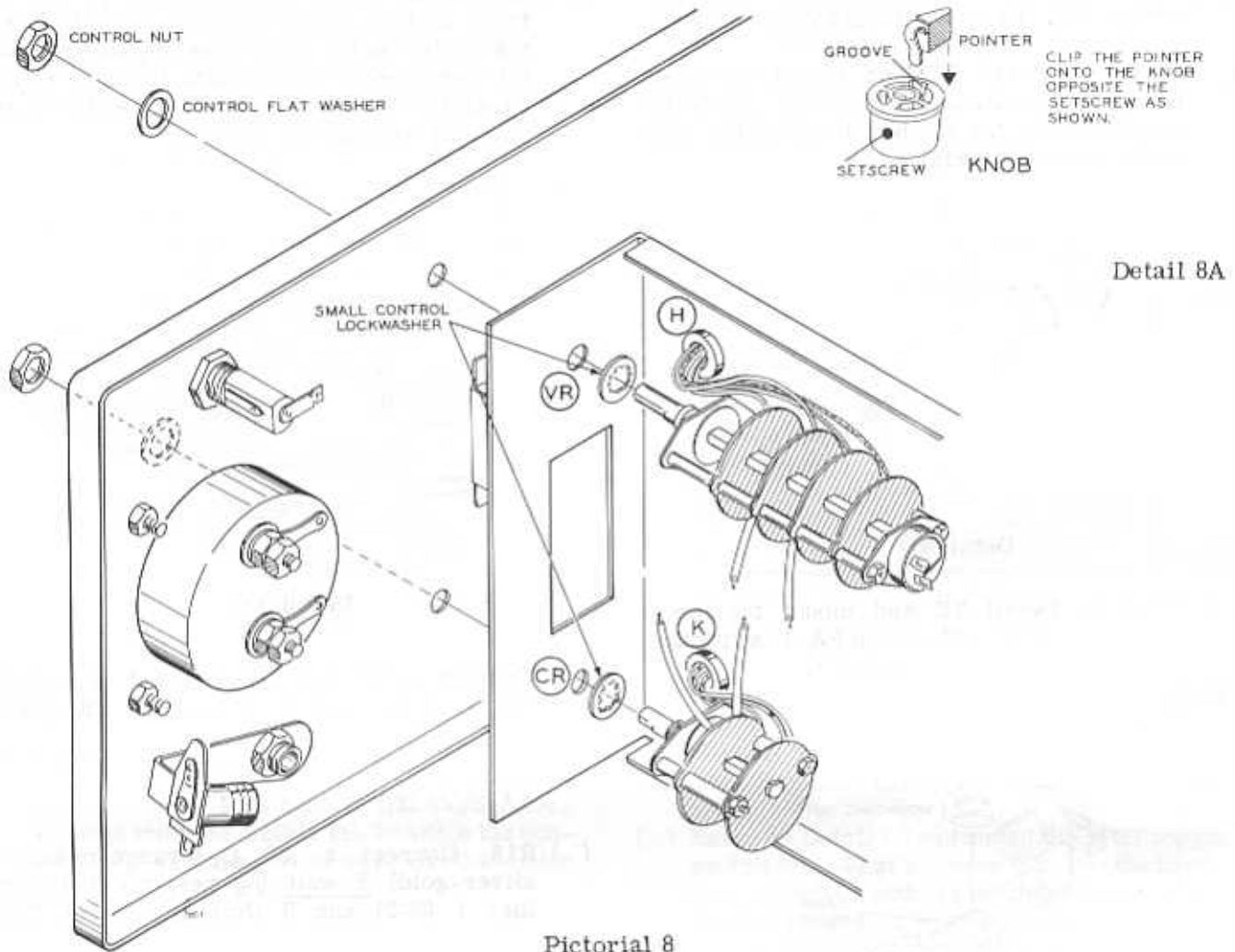

Pictorial 8

Detail 8A

Refer to Pictorial 8 for the following steps.

- () Position the main chassis on the front panel as shown in Pictorial 8.
- () Mount the CURRENT RANGE switch at location CR. Use a small control lockwasher, a control flat washer, and a control nut. Place the free ends of the wires extending from switch CR except for the shorter wire from lug 4 and the wire from lug 9 of the first wafer, through grommet K. Position the switch lugs and wires as shown.
- () Mount the VOLTAGE RANGE switch at location VR. Use a small control lockwasher, control flat washer, and a control nut.

Place the free ends of the wires extending from the switch, except the wire from lug 7 of the first wafer and the shorter wire from lug 6 of the second wafer, through grommet H. Position the switch lugs and wires as shown.

- () Select a knob and a pointer and assemble them as shown in Detail 8A. Now place the knob on the VOLTAGE RANGE switch and make sure the pointer points to all the dots on the front panel properly. Loosen the nut to rotate the switch if necessary, then re-tighten. Repeat this step for the CURRENT RANGE switch by installing another knob and pointer.



Refer to Pictorial 9 (fold-out from Page 29) for the following steps.

- () Place the longest two wires, one stripped and one unstripped, extending from grommet K, through grommet L to be connected later.
- () Connect the next longest stripped wire extending from grommet K (from lug 6, first wafer, switch CR) to lug 3 of terminal strip G (NS).
- () Connect the remaining unstripped wire extending from grommet K (from lug 5, second wafer, switch CR) to lug 3 of control FD (NS).
- () Connect the remaining stripped wire extending from grommet K (from lug 9, second wafer, switch CR) to lug 1 of control FD (S-1).
- () Connect a 5-1/2" wire from lug 2 of control FD (S-1) to lug 7 of terminal strip E (S-2).
- () Connect a 2" wire from lug 3 of control FD (S-2) to lug 4 of relay J (S-1).
- () Connect the free end of the wire extending from grommet L to solder lug 1 of binding post FH (NS).
- () Connect a 4" wire from lug 1 of toggle switch FF (NS) to lug 7 of terminal strip G (S-3).
- () Connect the free end of the longest stripped wire extending from grommet H (from lug 7 fourth wafer, switch VR) to lug 2 of terminal strip N (S-3).
- () Connect the free end of the next longest stripped wire extending from grommet H (from lug 8, first wafer, switch VR) to binding post base FG (S-3).
- () Locate the next longest stripped wire extending from grommet H (from lug 5, third wafer, switch VR). Pass it next to lug 3 (NS) and on to lug 2 (S-1) of control R. Now solder the lead to lug 3 (S-2).
- () Connect the next longest unstripped wire extending from grommet H (from lug 7, second wafer, switch VR) to lug 3 of control FE (S-1).
- () Connect the remaining stripped wire extending from grommet H (from lug 6, second wafer, switch VR) to lug 2 of terminal strip G (NS).
- () Connect the remaining unstripped wire extending from grommet H (from lug 6, third wafer, switch VR) to lug 1 of control FE (S-1).
- () Strip 1" of insulation from one end of a 3-3/4" wire and 1/4" from the other. Run the 1" stripped end through lugs 2 and lug 4 of transistor socket X2 (solder both lugs) and on to lug 5 of terminal strip G (S-4). Connect the other end to lug 2 of control FE (NS).
- () Connect a 4" wire from solder lug 1 of binding post FH (S-3) to lug 2 of terminal strip G (S-5).
- () Connect a 4" wire from lug 3 of control FK (S-2) to lug 3 of terminal strip G (S-3).
- () Connect a 4" wire from lug 2 of control FK (S-1) to lug 4 of terminal strip G (S-2).
- () C6. Connect the positive (+) lead of a 100 μ fd 50 V electrolytic capacitor (#25-128) to lug 2 of control FE (S-2). Connect the other lead to solder lug 2 of binding post FH (NS).
- () C4. Connect the positive (+) lead of a 500 μ fd 50 V electrolytic capacitor (#25-121) to lug 1 of toggle switch FF (S-3) and the other lead to solder lug 2 of binding post FH (S-2).
- () Locate the power transformer (#54-123) and place it on a flat surface. Make sure that the mounting feet are flat so that when the transformer is mounted it will not distort the chassis.

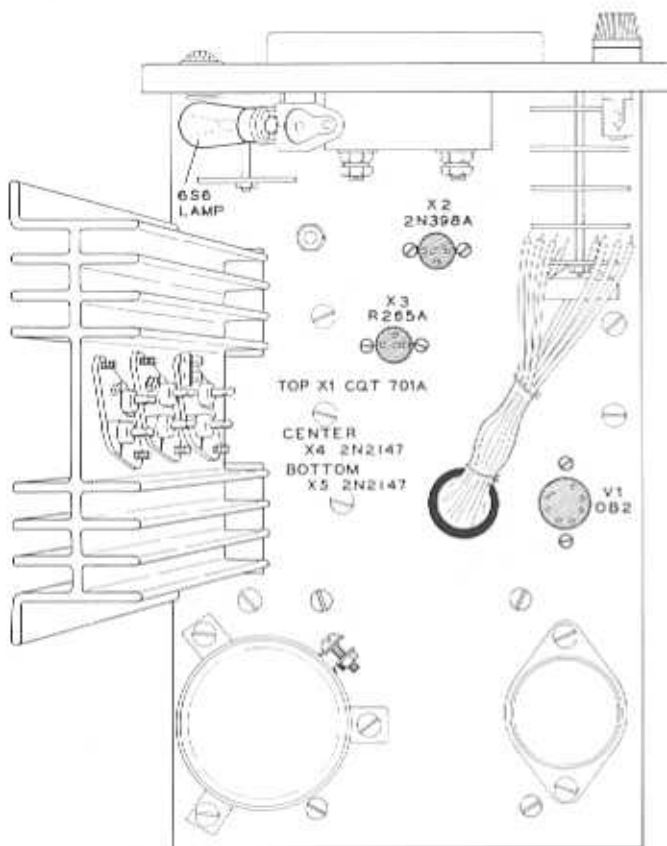

Pictorial 11

Refer to Pictorial 11 for the following steps.

- () Install the OB2 tube in tube socket V1.
- () Install the R265A transistor in transistor socket X3, after clipping the transistor leads to 1/4".

FINAL WIRING CHECKOUT

Because a wiring error may cause permanent damage to the transistors and diodes, the following quick wiring check should be made.

- () Make sure that the transformer leads going to the 4th wafer of the VOLTAGE RANGE switch are connected in the following order: blue, green, black-yellow, green-yellow, red-yellow, blue-yellow, gray, red-black, green-black, and red-green.

- () Place the small transistor heat sink on the 2N398A transistor. Now clip off the transistor leads to 1/4".
- () Install this transistor in transistor socket X2.
- () Install the 6 watt, 120 volt lamp in the lamp socket.
- () Install a 1-1/2 ampere fuse in the fuse holder.

Refer to Pictorial 12 for the following steps.

- () Refer to Detail 12A and install knob pointers on the two remaining knobs.

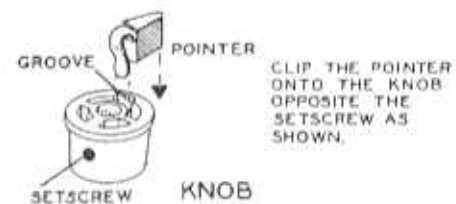

Detail 12A

- () Install knobs on the FINE VOLTAGE and CURRENT LIMIT controls. Position the knob pointers straight up, with the control shafts at the center of their rotation.
- () Install the three binding post caps. Place the red one on the plus (+) terminal.
- () Install the guard nut on the DC REGULATION control.

This completes assembly of your Power Supply. Proceed with the Initial Test And Adjustment.

See that the following wires are connected as listed:

- () The wire from lug C of X1 (CQT701A) to lug 4, 1st wafer of switch CR.
- () The wire from lug E of X1 to lug 6, 2nd wafer of switch CR.
- () The wire from lug B of X1 to lug 3 of terminal strip M.



- () The long wire from lug 1 of terminal strip T to lug 1 of 3000 μ fd capacitor P.
 - () The short wire from lug 1 of terminal strip T to lug 3 of transistor socket X3.
 - () The wire from lug 2 of terminal strip T to solder lug FH.
 - () The wire from lug B of X4 to lug 5 of terminal strip E.
 - () The short wire from lug 4, 1st wafer of switch CR to lug 1 of meter switch FC.
 - () The wire from lug 6, 1st wafer of switch CR to lug 3 of terminal strip G.
 - () The wire from lug 9, 1st wafer of switch CR to lug 4 of meter switch FC.
 - () The wire from lug 5, 2nd wafer of switch CR to lug 3 of control FD.
 - () The wire from lug 9, 2nd wafer of switch CR to lug 1 of control FD.
 - () Wire from lug 7, 1st wafer of switch VR to lug 3 of meter switch FC.
 - () The wire from lug 8, 1st wafer of switch VR to solder lug FG.
 - () The wire from lug 6, 2nd wafer of switch VR to lug 2 of terminal strip G.
 - () The wire from lug 7, 2nd wafer of switch VR to lug 3 of control FE.
 - () The wire from lug 5, 3rd wafer of switch VR to lugs 2 and 3 of control R.
 - () The wire from lug 6, 3rd wafer of switch VR to lug 1 of control FE.
 - () The wire from lug 7, 4th wafer of switch VR to lug 2 of terminal strip N.
- This completes the wiring checkout.

INITIAL TEST AND ADJUSTMENT

- () Place the front panel controls as follows:

VOLTAGE RANGE - AC OFF
 CURRENT RANGE - 1.5 A
 FINE VOLTAGE - Center of rotation
 CURRENT LIMIT - MAX CURRENT
 METER - Voltage
 DC REGULATION - 1/8 turn from full counterclockwise
 Toggle Switch- RESET STANDBY

- () Set the controls on the control plate as follows:

ZENER CURRENT - Full counterclockwise
 VOLTAGE CALIBRATE - Center of rotation
 METER - ZENER CURRENT

- () Adjust the mechanical zero of the meter with a screwdriver if necessary.
- () Plug the line cord into a standard 117 volt 50/60 cps AC power source. Turn the VOLTAGE RANGE switch to the 5 volt position.
- () Adjust the ZENER CURRENT control for a 5 ma (full scale) reading on the meter.



Pictorial 12

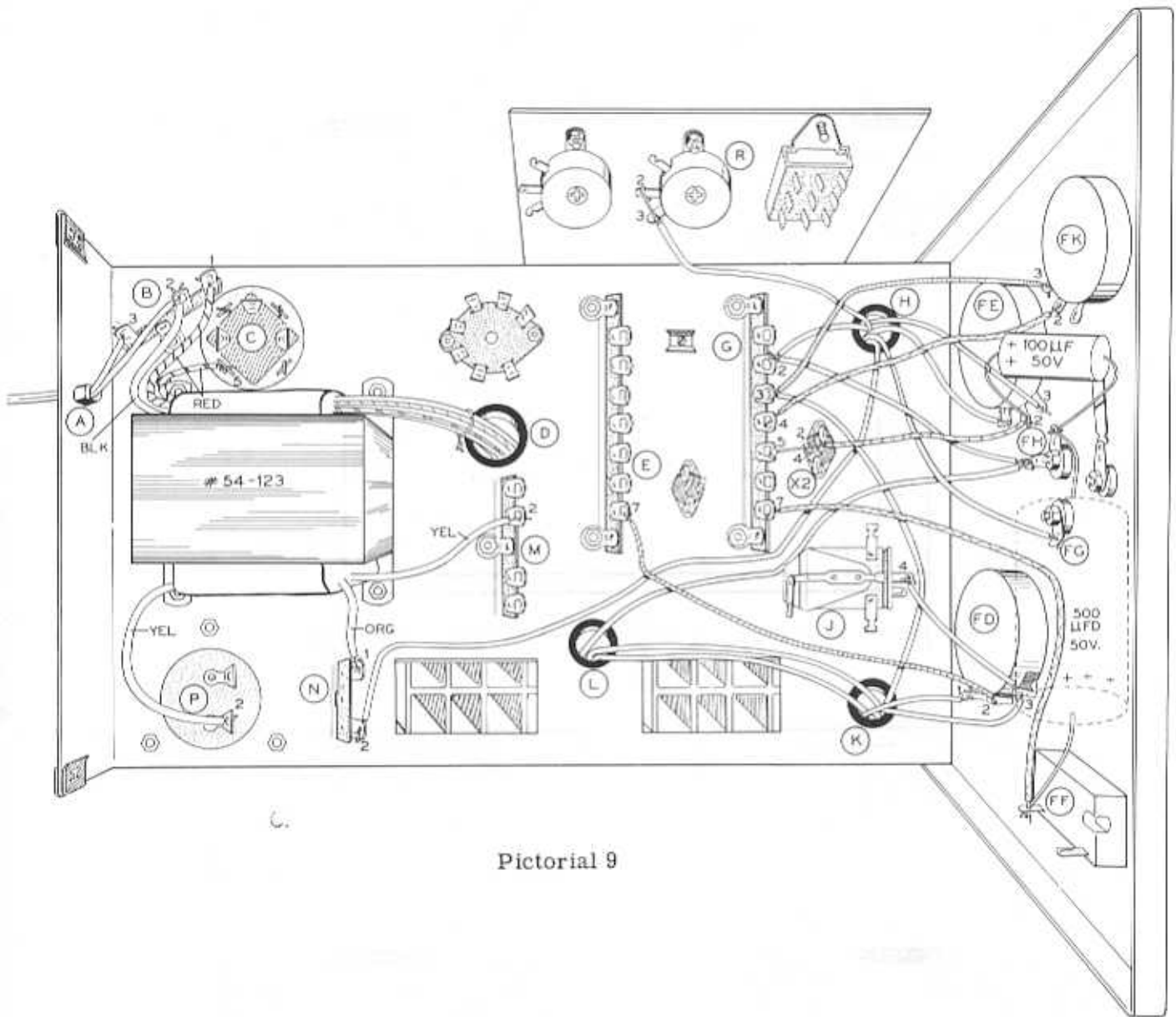

Pictorial 9

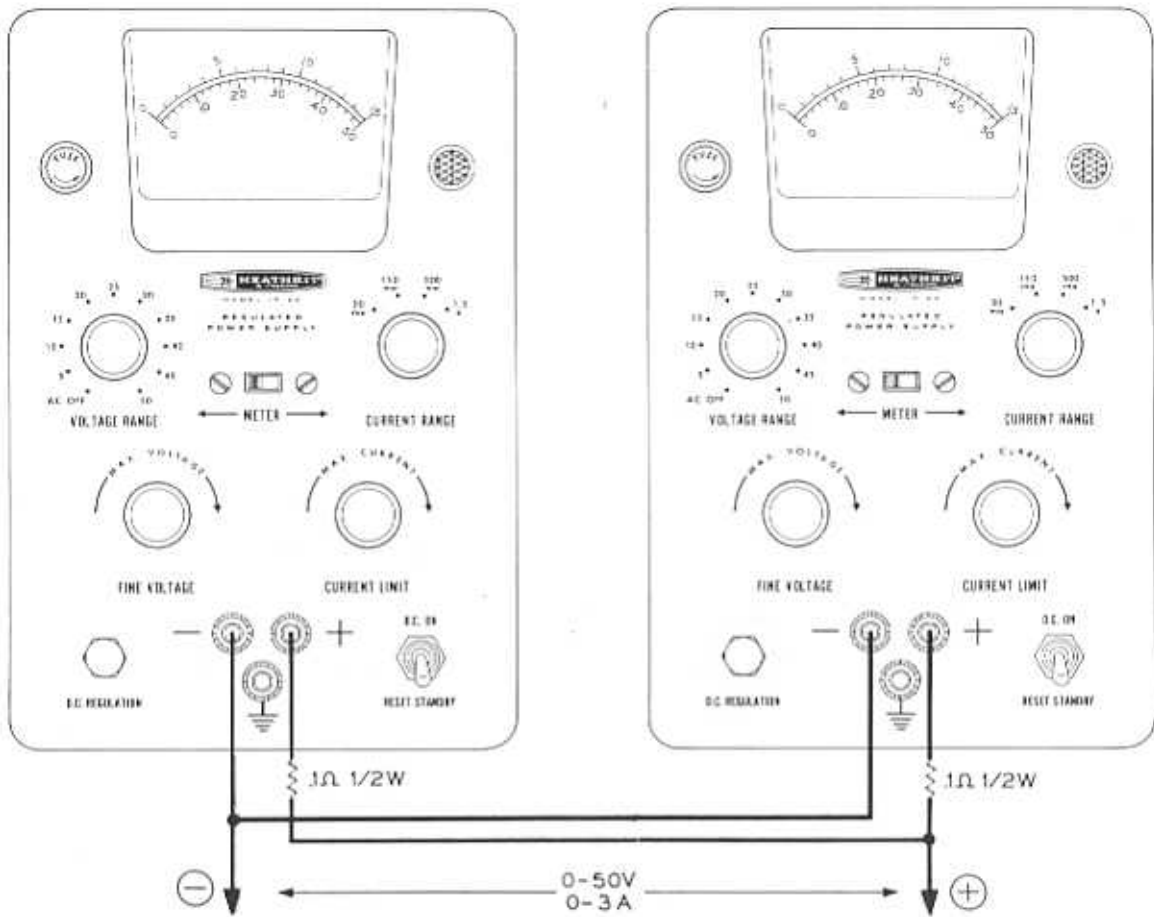

Figure 7

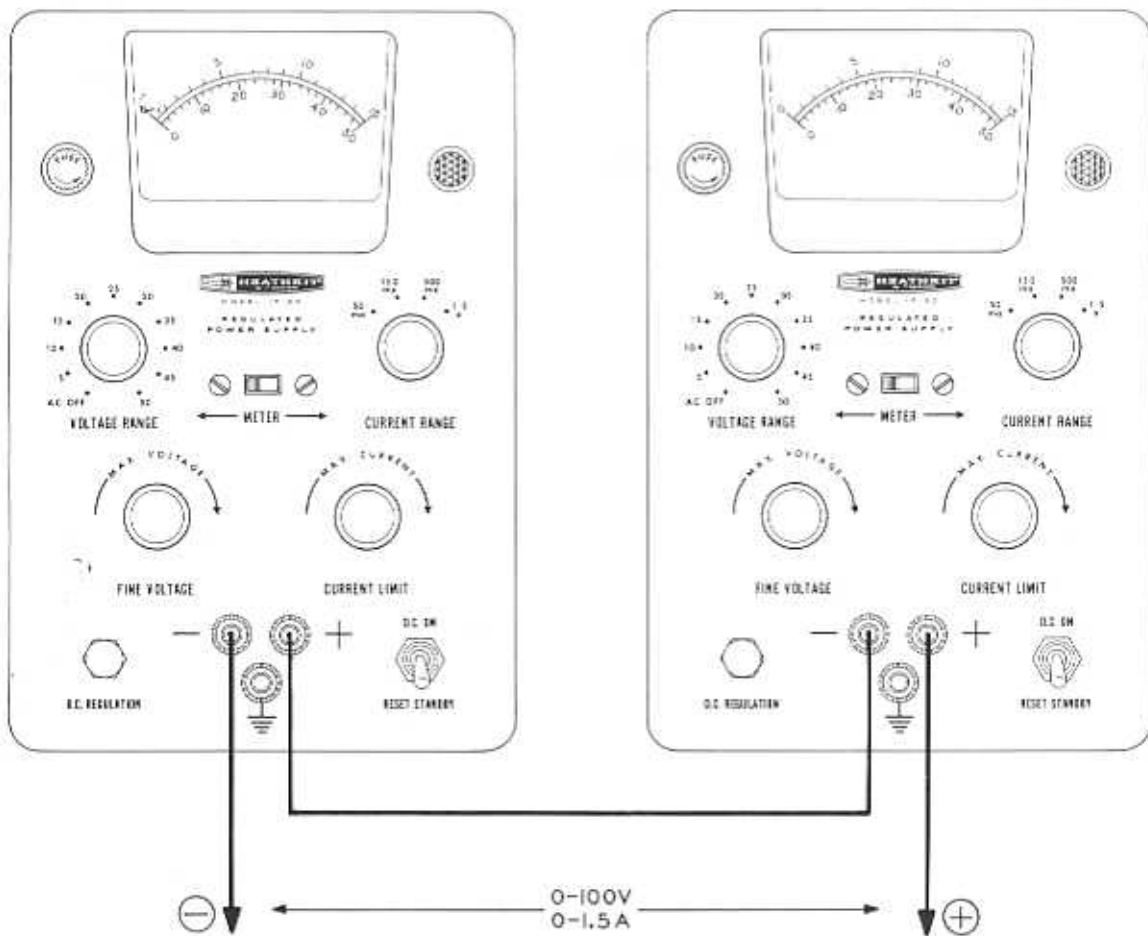

Figure 8

- () Place the METER switch on the control plate in the NORMAL position and set the toggle switch to DC ON.
- () Turn the FINE VOLTAGE control back and forth and watch the meter. The voltage reading should swing from almost zero to more than full scale. If operation appears normal, continue with the following steps. If there appears to be any difficulty, refer to the In Case Of Difficulty section of the manual.
- () With the FINE VOLTAGE control at the MAX VOLTAGE position, slowly turn the VOLTAGE RANGE switch to the 50 volt position. At each step, check the voltmeter reading. The 10 and 15 volt ranges use the 15 scale. The remaining ranges use the 50 scale.
- () Make sure that the FINE VOLTAGE control is fully clockwise. Now adjust the VOLTAGE CALIBRATE control for a 50 volt reading on the meter.
- () Place the METER switch on the control plate to the ZENER CURRENT position and adjust the ZENER CURRENT control for a 5 ma (full-scale) reading on the meter.
- () Return the METER switch to the NORMAL position and, if necessary, recalibrate for a 50 volt reading. Repeat these two steps until the METER switch can be moved from the ZENER CURRENT to the NORMAL position with no change in the meter reading. Leave the METER switch in the NORMAL position.
- () Return the VOLTAGE RANGE switch to the AC OFF position. Do not rotate this switch faster than a moderate speed as the voltage transients may damage the transistors.

FINAL ASSEMBLY

Refer to Pictorial 13 for the following steps.

- () Mount a rubber foot in each corner on the bottom of the cabinet. Use a 6-32 x 5/8" screw, a #8 flat washer, #6 lockwasher, and a 6-32 nut.
- () Mount the black plastic handle on the top of the cabinet with the two #10 sheet metal screws.
- () Place the Power Supply on its face (front panel down). Feed the line cord through the cutout in the back of the cabinet and slide the cabinet over the Power Supply.
- () Secure the cabinet with four 6-32 x 3/8" screws in the 6-32 speednuts on the rear mounting plate.

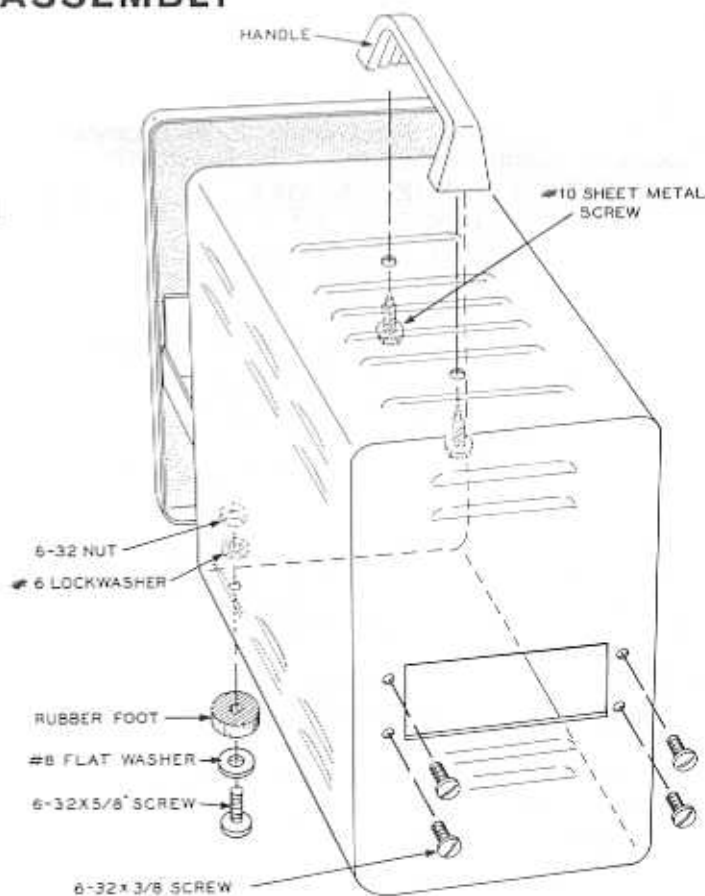

Pictorial 13

FINAL ADJUSTMENT

NOTE: If a differential voltmeter is available it may be used for the following adjustment. Also, if it is not convenient to do the next five steps, leave the DC REGULATION control as originally set. It will be very close to optimum.

- () Locate a load that will withstand 1.5 amperes at 15 volts (10 ohms, 22.5 watts).
- () Turn the VOLTAGE RANGE switch to the 15 volt position and the METER switch in the Voltage position.
- () Turn the CURRENT RANGE switch to the 1.5 A range and the CURRENT LIMIT control to the maximum clockwise position.
- () Remove the guard nut from the DC REGULATION control.
- () Observe the meter and alternately touch the load across the + and - binding posts and adjust the DC REGULATION control until there is no change in the meter reading as the load is connected and disconnected from the binding posts. This setting will give the regulation characteristic shown in Figure 6.
- () Replace the guard nut on the DC REGULATION control.

This completes the adjustment of your Power Supply.

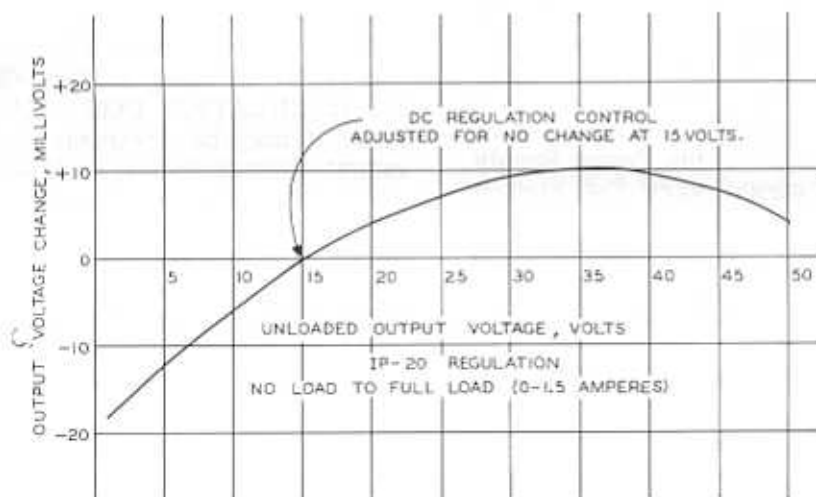

Figure 6

OPERATION

USES

AMMETER USE - When using the Power Supply on the ranges of 50 or 150 ma, there is a 2 ma offset in the meter reading. To correct for this condition, subtract 2 ma from the meter reading. This result will then be the actual current drawn by the load.

CURRENT LIMITER USE - The Power Supply will supply a maximum current (peak plus average current) of 1.5 amperes. This means that the Power Supply will not operate a load that requires 1.5 amperes under "no signal" conditions, as the current limiter circuit in the Power Supply would automatically cut the Power Supply off as the load began drawing more than 1.5 amperes under signal conditions. For example, a transistorized audio amplifier requires 1.0 ampere under no-signal conditions. If a sine wave is applied to the amplifier, the current demand on the Power Supply will also vary in a sine wave fashion. With a 1.0 ampere no-signal level, the current drain can vary .5 ampere without limiting in the Power Supply. However should the signal vary the current demand more than .5 ampere the Power Supply will clip. See Figure 5 on Page 5. This condition can be minimized by connecting a very large capacitor (1000 μ fd or more)

across the output of the Power Supply. The capacitor will discharge into the load during the limiting period and, therefore, reduce the clipping action.

CAUTION: When using the large capacitor, it must be completely discharged before it is connected across the output of the Power Supply. Always start the Power Supply with the VOLTAGE RANGE switch at the lowest range and slowly increase the voltage to the desired level. This will prevent any high current surge that may cause the overload relay in the Power Supply to open.

OVERLOAD RELAY - The relay will open when the output voltage is greater than 7 volts and in the event of a short circuited load, or a load that has become a very low resistance. To reset the relay, push the toggle switch to the RESET STANDBY position. When the load is fixed, return the toggle switch to DC ON.

DC REGULATION CONTROL - On rare occasions, it may be desirable to have no change in output voltage (better than ± 15 millivolts) from no load to full load. In this event simply adjust the DC REGULATION control at the desired output voltage for no voltage change from no load to full load. Return the control to its original setting after this application is completed.

CONTROL USE

- () Place the front panel controls as follows:

VOLTAGE RANGE - AC OFF
 CURRENT RANGE - 1.5A
 CURRENT LIMIT - Full clockwise
 FINE VOLTAGE - Full counterclockwise
 METER - Voltage
 Toggle Switch - RESET STANDBY

- () Turn the VOLTAGE RANGE switch to the desired range and adjust the FINE VOLTAGE control for the desired voltage as indicated by the meter. CAUTION: Do not rotate the VOLTAGE RANGE switch rapidly as transients will damage the transistors.
- () Place the METER switch to read Current and place the CURRENT RANGE switch to the desired current range.
- () Connect the load to the proper binding posts.
- () Place the toggle switch in the DC ON position.
- () Rotate the CURRENT LIMIT control counterclockwise until the current reading on the meter starts to decrease, then turn the CURRENT LIMIT control clockwise to just above this point. This adjustment will automatically limit the current output of the Power Supply and thereby protect the load and the Power Supply.

PARALLEL OPERATION (FIGURE 7)

Two or more Power Supplies can be connected in parallel for high current loads. See Figure 7 (fold-out from Page 30). Before connecting the Power Supplies in parallel set the VOLTAGE RANGE, FINE VOLTAGE, CURRENT RANGE, and CURRENT LIMIT controls on both Power Supplies so that the output of each Supply is identical to the other. A .1 Ω resistor is also

placed in the plus (+) lead of each Power Supply.

- () Place the METER switch in both Power Supplies to read voltage.
- () Connect the two (-) binding posts together.
- () Turn the toggle switch of both Power Supplies to DC ON.
- () Lightly touch the (+) leads (after the .1 Ω resistors) of the two Supplies together. Watch the meter on both Supplies. If the meter reading on one Power Supply increases while the meter reading on the other Power Supply decreases, adjust the FINE VOLTAGE control on either Power Supply until the (+) leads of the Power Supplies can be touched together with no change in meter readings. The (+) leads can now be connected together.
- () The toggle switch on both Power Supplies must be in DC ON position when connected for parallel operation.

Each time a change in control settings is made on one Power Supply, be sure that it is made on the other while the Supplies are not connected together or while the toggle switches are in the reset position.

SERIES OPERATION (FIGURE 8)

Two or more Power Supplies can be connected in series for voltages greater than 50 volts. See Figure 8 (fold-out from Page 30). Before a load is connected to the series combination, set the CURRENT RANGE switch and CURRENT LIMIT control the same on each Power Supply. The toggle switch on all but one Supply can be left in the DC ON position. The switch of the Power Supply connected to the (+) side of the load can be used for standby.

IN CASE OF DIFFICULTY

1. Recheck the wiring. Trace each lead in colored pencil on the Pictorial as it is checked. It is frequently helpful to have a friend check your work. Someone who is not familiar with the unit may notice something consistently overlooked by the constructor.
2. It is interesting to note that about 90% of the kits that are returned for repair, do not function properly due to poor connections and soldering. Therefore, many troubles can be eliminated by reheating all connections to make sure that they are soldered as described in the Proper Soldering Techniques section of this manual.
3. Check the values of the parts. Be sure that the proper part has been wired into the circuit, as shown in the pictorial diagrams and as called out in the wiring instructions.
4. Check for bits of solder, wire ends or other foreign matter which may be lodged in the wiring.
5. If, after careful checks, the trouble is still not located and a voltmeter is available, check voltage readings against those shown on the Schematic Diagram. NOTE: All voltage readings were taken with an 11 megohm input vacuum tube voltmeter. Voltages may vary as much as 10%.
6. A review of the Circuit Description will prove helpful in indicating where to look for trouble.

TROUBLESHOOTING CHART

TROUBLE	CHECK
Pilot lamp will not light.	<ol style="list-style-type: none"> 1. Fuse 2. AC Power switch. 3. OB2 tube. 4. 6S6 lamp.
High output voltage or no response from FINE VOLTAGE control.	<ol style="list-style-type: none"> 1. X4, X5, 2N2147 (short). 2. X3, R265A (short). 3. X2, 2N398A (short).
Low output voltage or no response from FINE VOLTAGE control.	<ol style="list-style-type: none"> 1. X2, 2N398A (short). 2. X1, CQT701A (open). 3. Bias supply for CQT701A. 4. Diodes D1, D2, D3, D4. 5. Transformer. 6. Zener diode, Z1, supply.
High zener current or low zener current.	<ol style="list-style-type: none"> 1. OB2 tube. 2. R47 control (ZENER CURRENT ADJUST). 3. R43 control (VOLTAGE CALIBRATE). 4. Zener diode, Z1.
Loss of current limiting.	<ol style="list-style-type: none"> 1. X1, CQT701A (shorted). 2. Diode D6.
Relay will not operate.	<ol style="list-style-type: none"> 1. Relay. 2. Diode D7.
Power Supply oscillates.	<ol style="list-style-type: none"> 1. Faulty C4. Adding capacity (approximately 100 μfd) in parallel with C4 will usually stop oscillations.

SERVICE INFORMATION

SERVICE

If, after applying the information in this manual and your best efforts, you are still unable to obtain proper performance, it is suggested that you take advantage of the technical facilities which the Heath Company makes available to its customers.

The Technical Consultation Department is maintained for your benefit. This service is available to you at no charge. Its primary purpose is to provide assistance for those who encounter difficulty in the construction, operation or maintenance of HEATHKIT equipment. It is not intended, and is not equipped to function as a general source of technical information involving kit modifications nor anything other than the normal and specified performance of HEATHKIT equipment.

Although the Technical Consultants are familiar with all details of this kit, the effectiveness of their advice will depend entirely upon the amount and the accuracy of the information furnished by you. In a sense, YOU MUST QUALIFY for GOOD technical advice by helping the consultants to help you. Please use this outline:

1. Before writing, fully investigate each of the hints and suggestions listed in this manual under In Case Of Difficulty. Possibly it will not be necessary to write.
2. When writing, clearly describe the nature of the trouble and mention all associated equipment. Specifically report operating procedures, switch positions, connections to other units, and anything else that might help to isolate the cause of trouble.
3. Report fully on the results obtained when testing the unit initially and when following the suggestions under In Case Of Difficulty. Be as specific as possible and include voltage readings if test equipment is available.
4. Identify the kit model number and date of purchase, if available. Also mention the date of the kit assembly manual. (Date at bottom of Page 1.)

5. Print or type your name and address, preferably in two places on the letter.

With the preceding information, the consultant will know exactly what kit you have, what you would like it to do for you and the difficulty you wish to correct. The date of purchase tells him whether or not engineering changes have been made since it was shipped to you. He will know what you have done in an effort to locate the cause of trouble and, thereby, avoid repetitious suggestions. In short, he will devote full time to the problem at hand, and through his familiarity with the kit, plus your accurate report, he will be able to give you a complete and helpful answer. If replacement parts are required, they will be shipped to you, subject to the terms of the Warranty.

The Factory Service facilities are also available to you, in case you are not familiar enough with electronics to provide our consultants with sufficient information on which to base a diagnosis of your difficulty, or in the event that you prefer to have the difficulty corrected in this manner. You may return the completed equipment to the Heath Company for inspection and necessary repairs and adjustments. You will be charged a minimal service fee, plus the price of any additional parts or material required. However, if the completed kit is returned within the Warranty period, parts charges will be governed by the terms of the Warranty. State the date of purchase, if possible.

Local Service by Authorized HEATHKIT Service Centers is also available in some areas and often will be your fastest, most efficient method of obtaining service for your HEATHKIT equipment. Although charges for local service are generally somewhat higher than for factory service, the amount of increase is usually offset by the transportation charge you would pay if you elected to return your kit to the Heath Company.

HEATHKIT Service Centers will honor the regular 90 day HEATHKIT Parts Warranty on all kits, whether purchased through a dealer or directly from Heath Company; however, it will be necessary that you verify the purchase date of your kit.

Under the conditions specified in the Warranty, replacement parts are supplied without charge; however, if the Service Center assists you in locating a defective part (or parts) in your kit, or installs a replacement part for you, you may be charged for this service.

HEATHKIT equipment purchased locally and returned to Heath Company for service must be accompanied by your copy of the dated sales receipt from your authorized HEATHKIT dealer in order to be eligible for parts replacement under the terms of the Warranty.

THIS SERVICE POLICY APPLIES ONLY TO COMPLETED EQUIPMENT CONSTRUCTED IN ACCORDANCE WITH THE INSTRUCTIONS AS STATED IN THE MANUAL. Equipment that has been modified in design will not be accepted for repair. If there is evidence of acid core solder or paste fluxes, the equipment will be returned NOT repaired.

For information regarding modification of HEATHKIT equipment for special applications, it is suggested that you refer to any one or more of the many publications that are available on all phases of electronics. They can be obtained at or through your local library, as well as at most electronic equipment stores. Although the Heath Company sincerely welcomes all comments and suggestions, it would be impossible to design, test, evaluate and assume responsibility for proposed circuit changes for special purposes. Therefore, such modifications must be made at the discretion of the kit builder, using information available from sources other than the Heath Company.

REPLACEMENTS

Material supplied with HEATHKIT products has been carefully selected to meet design requirements and ordinarily will fulfill its function without difficulty. Occasionally, improper operation can be traced to a faulty component. Should inspection reveal the necessity for replacement, write to the Heath Company and supply all of the following information.

- A. Thoroughly identify the part in question by using the part number and description found in the manual Parts List.

- B. Identify the type and model number of kit in which it is used.
- C. Mention date of purchase.
- D. Describe the nature of defect or reason for requesting replacement.

The Heath Company will promptly supply the necessary replacement. PLEASE DO NOT RETURN THE ORIGINAL COMPONENT UNTIL SPECIFICALLY REQUESTED TO DO SO. Do not dismantle the component in question as this will void the guarantee. This replacement policy does not cover the free replacement of parts that may have been broken or damaged through carelessness on the part of the kit builder.

SHIPPING INSTRUCTIONS

In the event that your instrument must be returned for service, these instructions should be carefully followed.

Wrap the equipment in heavy paper, exercising care to prevent damage. Place the wrapped equipment in a stout carton of such size that at least three inches of shredded paper, excelsior, or other resilient packing material can be placed between all sides of the wrapped equipment and the carton. Close and seal the carton with gummed paper tape, or alternately, tie securely with stout cord. Clearly print the address on the carton as follows:

To: HEATH COMPANY
Benton Harbor, Michigan

ATTACH A LETTER TO THE OUTSIDE OF THE CARTON BEARING YOUR NAME, COMPLETE ADDRESS, DATE OF PURCHASE, AND A BRIEF DESCRIPTION OF THE DIFFICULTY ENCOUNTERED. Also, include your name and return address on the outside of the carton. Preferably affix one or more "Fragile" or "Handle With Care" labels to the carton, or otherwise so mark with a crayon of bright color. Ship by insured parcel post or prepaid express; note that a carrier cannot be held responsible for damage in transit if, in HIS OPINION, the article is inadequately packed for shipment.



WARRANTY

Heath Company warrants that for a period of three months from the date of shipment, all Heathkit parts shall be free of defects in materials and workmanship under normal use and service and that in fulfillment of any breach of such warranty, Heath Company shall replace such defective parts upon the return of the same to its factory. The foregoing warranty shall apply only to the original buyer, and is and shall be in lieu of all other warranties, whether express or implied and of all other obligations or liabilities on the part of Heath Company and in no event shall Heath Company be liable for any anticipated profits, consequential damages, loss of time or other losses incurred by the buyer in connection with the purchase, assembly or operation of Heathkits or components thereof. No replacement shall be made of parts damaged by the buyer in the course of handling or assembling Heathkit equipment.

NOTE: The foregoing warranty is completely void and we will not replace, repair or service instruments or parts thereof in which acid core solder or paste fluxes have been used.

HEATH COMPANY

TYPICAL COMPONENT TYPES

This chart is a guide to commonly used types of electronic components. The symbols and related illustrations

should prove helpful in identifying most parts and reading the schematic diagrams.

<p style="text-align: center;">RESISTOR</p>	<p style="text-align: center;">CAPACITOR</p>	<p style="text-align: center;">TUBE</p>
<p style="text-align: center;">POTENTIOMETER (CONTROL)</p>	<p style="text-align: center;">ELECTROLYTIC CAPACITOR</p>	<p style="text-align: center;">TRANSISTOR</p>
<p style="text-align: center;">TRANSFORMER (IRON CORE)</p>	<p style="text-align: center;">VARIABLE CAPACITOR</p>	<p style="text-align: center;">RECTIFIER (DIODE)</p>
<p style="text-align: center;">TRANSFORMER (ADJUSTABLE POWDERED IRON CORE) ARROW INDICATES DIRECTION OF CORE MOVEMENT TO INCREASE INDUCTANCE</p>	<p style="text-align: center;">BATTERY</p>	<p style="text-align: center;">NEON BULB</p>
<p style="text-align: center;">TRANSFORMER (ADJUSTABLE CORE)</p>	<p style="text-align: center;">PHONO JACK</p>	<p style="text-align: center;">ILLUMINATING BULB</p>
<p style="text-align: center;">POWER TRANSFORMER</p>	<p style="text-align: center;">PHONE JACK</p>	<p style="text-align: center;">METER</p>
<p style="text-align: center;">INDUCTOR (COIL)</p>	<p style="text-align: center;">RECEPTACLE</p>	<p style="text-align: center;">SWITCH (TOGGLE)</p>
<p style="text-align: center;">PIEZOELECTRIC CRYSTAL</p>	<p style="text-align: center;">SPEAKER</p>	<p style="text-align: center;">SWITCH (ROTARY)</p>
<p style="text-align: center;">BINDING POST</p>	<p style="text-align: center;">MICROPHONE</p>	<p style="text-align: center;">FUSE</p>
<p style="text-align: center;">ANTENNA</p>	<p style="text-align: center;">EARTH GROUND</p>	<p style="text-align: center;">CONDUCTORS</p>

HEATH COMPANY

BENTON HARBOR, MICHIGAN

D *a subsidiary of*
DAYSTROM, INCORPORATED

THE WORLD'S FINEST ELECTRONIC EQUIPMENT IN KIT FORM

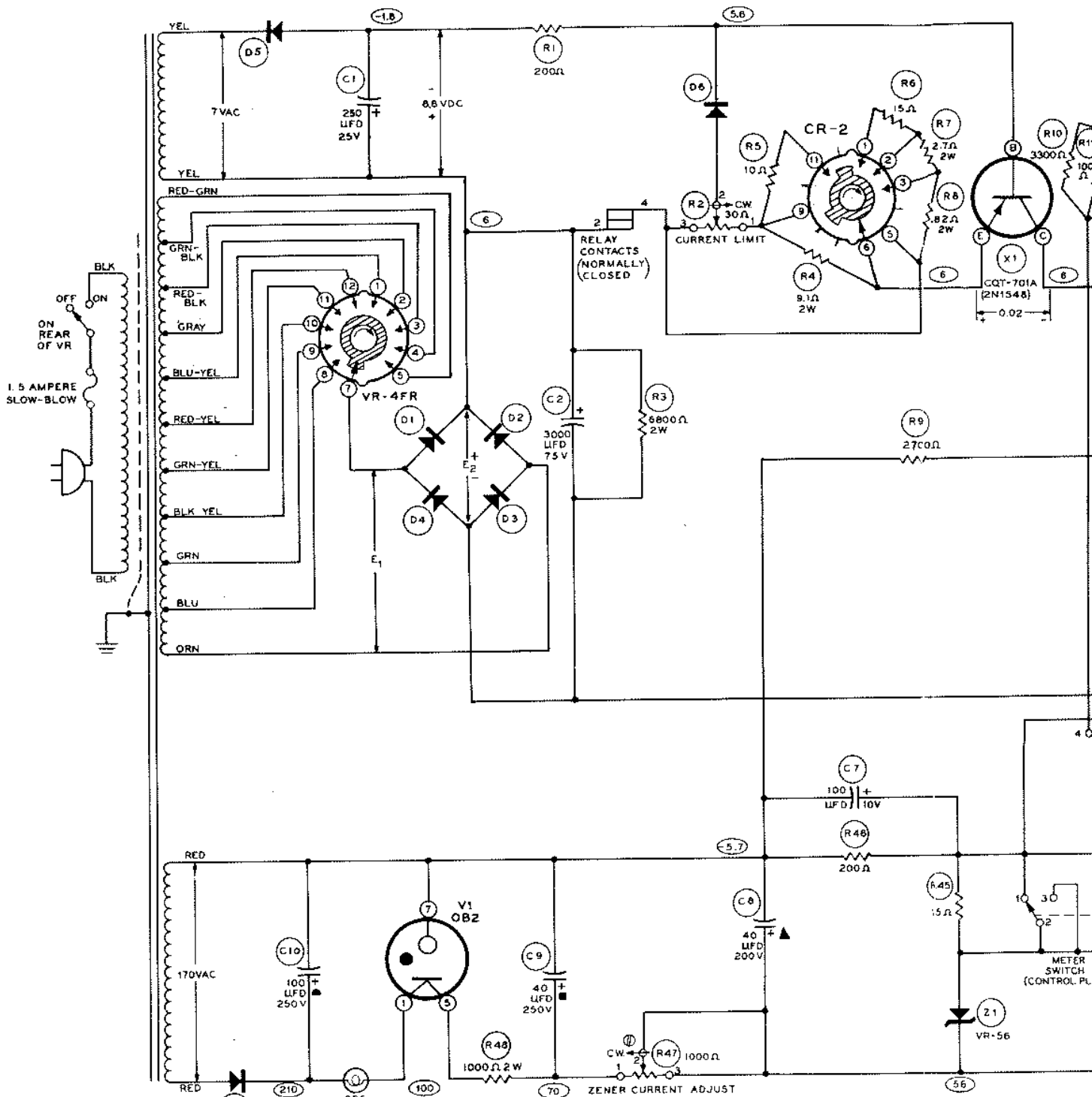

**SCHEMATIC OF THE
HEATHKIT®
TRANSISTORIZED REGULATED
POWER SUPPLY
MODEL IP-20**

NOTES:

1. ALL VOLTAGES TAKEN AT 117 VOLTS, 60 CPS INPUT.
2. ALL VOLTAGES READ WITH A VTVM.
3. CONTROLS SET AS FOLLOWS FOR VOLTAGE MEASUREMENTS:
 VOLTAGE RANGE - 5
 CURRENT RANGE - 1.5 A
 FINE VOLTAGE - MAX clockwise
 CURRENT LIMIT - MAX clockwise
 TOGGLE SWITCH - Reset-standby
 METER SWITCH - Voltage
4. ALL VOLTAGES MEASURED FROM NEGATIVE (-) OUTPUT TERMINAL UNLESS OTHERWISE INDICATED. ○ INDICATES VOLTAGE READING.
5. ALL VOLTAGES ARE DC UNLESS OTHERWISE INDICATED.
6. VOLTAGE READINGS CAN VARY ±10%.
7. OUTPUT UNLOADED.
8. ROTARY SWITCHES SHOWN IN MAXIMUM COUNTERCLOCKWISE POSITION.

POSITION OF VR	E1 VOLTS AC	E2 VOLTS DC	E3 VOLTS DC
5	10	14	5
10	15	21	10
15	20	28	15
20	25	35	20
25	29	41	25
30	33	47	30
35	38	54	35
40	43	60	40
45	47	66	45
50	53	74	50

Set controls as in note 3 except for Voltage Range (VR) switch.

ALL RESISTANCES IN OHMS K = 1000.
ALL RESISTORS 1/2 WATT UNLESS OTHERWISE SPECIFIED.

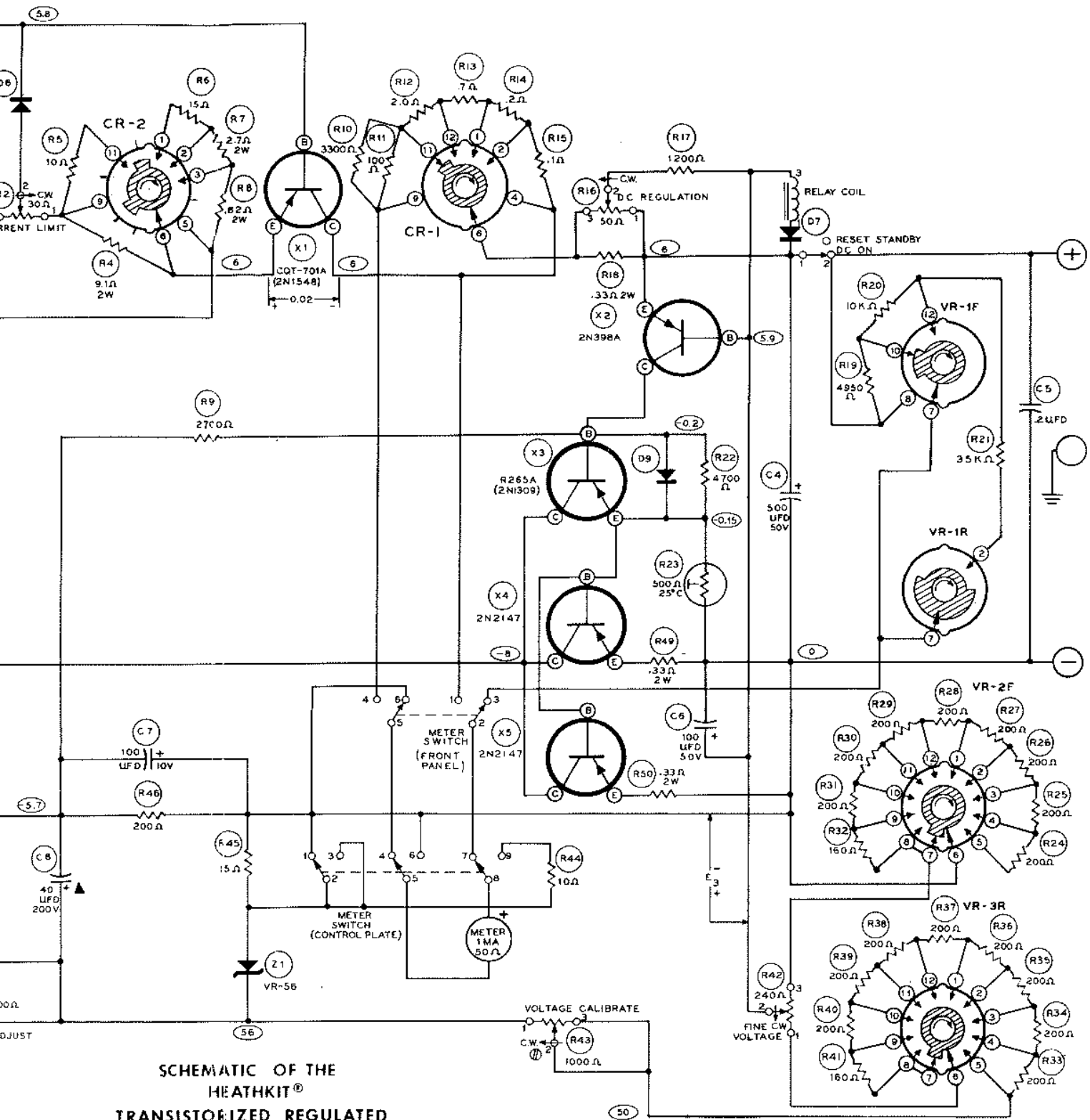

SCHEMATIC OF THE
HEATHKIT®
TRANSISTORIZED REGULATED
POWER SUPPLY
MODEL IP-20

ALL RESISTANCES IN OHMS K = 1000.

ALL RESISTORS 1/2 WATT UNLESS OTHERWISE SPECIFIED.

3
6
10
15
20
25
30
35
40
45
50

for