

SCHEMATIC OF THE
HEATHKIT[®] BATTERY ELIMINATOR
MODEL IP - 12

SPECIFICATIONS

Continuously Variable Output -

6 Volt Range.	<p><u>Partially Filtered</u> 0-8 volts, no load. 0-7 volts at 10 amperes, continuous. 0-6 volts at 15 amperes, maximum.</p> <p><u>Well Filtered</u> 0-6 volts at 5 amperes continuous with less than 0.3% ripple.</p>
12 Volt Range.	<p><u>Partially Filtered</u> 0-16 volts, no load. 0-14 volts at 5 amperes, continuous. 0-12 volts at 7.5 amperes, maximum.</p> <p><u>Well Filtered</u> 0-12 volts at 5 amperes continuous with less than 0.3% ripple.</p>
Power Requirements.	105 to 125 volts, 50/60 cps AC, 200 watts fully loaded.
Dimensions.	13" wide x 8-1/2" high x 7" deep.
Net Weight.	20 lbs.
Shipping Weight.	23 lbs.

INTRODUCTION

The Heathkit Model IP-12 Battery Eliminator incorporates in its design a well-filtered low-ripple output, as well as the standard partially filtered output. This increases the usefulness of the Battery Eliminator, as it may be used for servicing transistor and "Hybrid" car radios and devices incorporating space charge tubes and transistors. Output current and voltage are continuously metered for convenience of operation.

To list only a few possible uses for the Battery Eliminator:

1. Car radio servicing (vibrator, Hybrid, and transistor types).
2. Transistor radio servicing.
3. Battery charging.
4. Supply for electrolysis and plating processes.
5. Supply for small DC motors (car clocks and electric trains).
6. Supply for various types of electronic equipment.

CIRCUIT DESCRIPTION

Refer to the Schematic Diagram while reading the Circuit Description to aid in understanding the circuit.

AC line voltage is applied to the fuse-protected primary winding of power transformer T1.

Transformer T1 has two separate secondary windings which are connected together by direct contact of the movable wiper arm of the Voltage Control.

Turning the Voltage Control clockwise increases the number of turns of the secondary windings

that are used, thus applying more voltage to the rectifier circuit. This voltage can be varied from 0 to approximately 8 volts, depending on the load connected to the output terminals of the Battery Eliminator.

6 VOLT OPERATION

With the Range Switch in the 6 Volts position, the power rectifier, magnesium copper sulfide diodes D1 through D4, is connected to form a full-wave bridge rectifier. See Figure 1. The ripple in the resulting DC voltage from the rectifier is then partially filtered (smoothed) by capacitor C1. From C1, the DC voltage is applied through the ammeter to the partially filtered positive (+) output terminal.

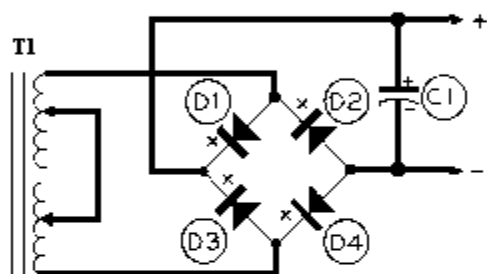

Figure 1

Additional filtering is provided by choke L1 and capacitor C3, which reduce the ripple. This DC voltage is available between the

negative (-) and the Well Filtered positive (+) output terminals. The voltmeter is connected between the Well Filtered output terminals.

12 VOLT OPERATION

Placing the Range Switch in the 12 Volts position connects the power rectifier diodes as a voltage-doubler circuit to produce the necessary higher voltage. See Figure 2. The ripple in the

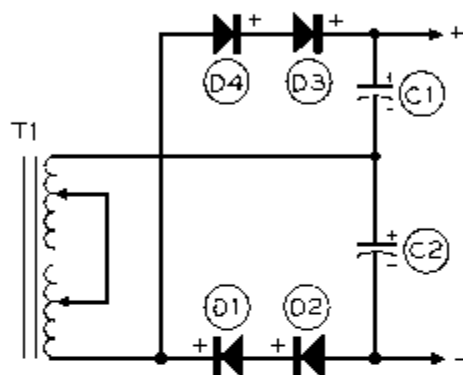
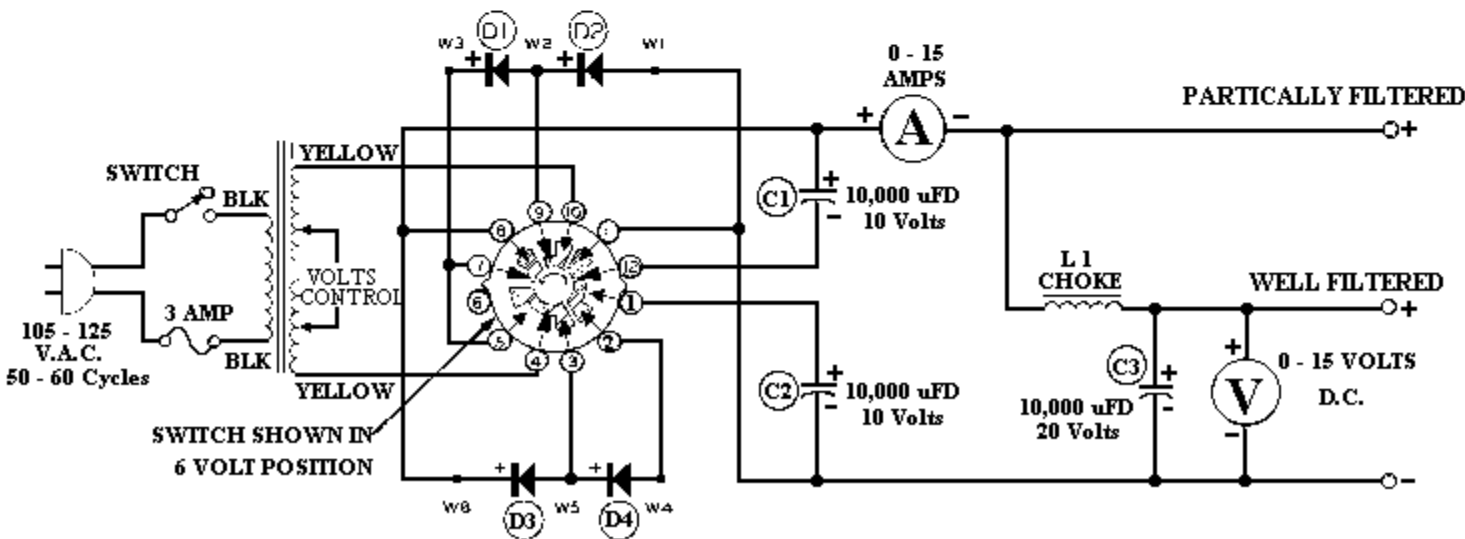

Figure 2

resulting DC voltage is partially filtered by capacitors C1 and C2, and is applied through the ammeter to the Partially Filtered output terminals. Additional filtering is provided by choke AC1 and capacitor C3 and is available at the Well Filtered terminals.



SCHEMATIC OF THE
HEATHKIT BATTERY ELIMINATOR
MODEL IP - 12