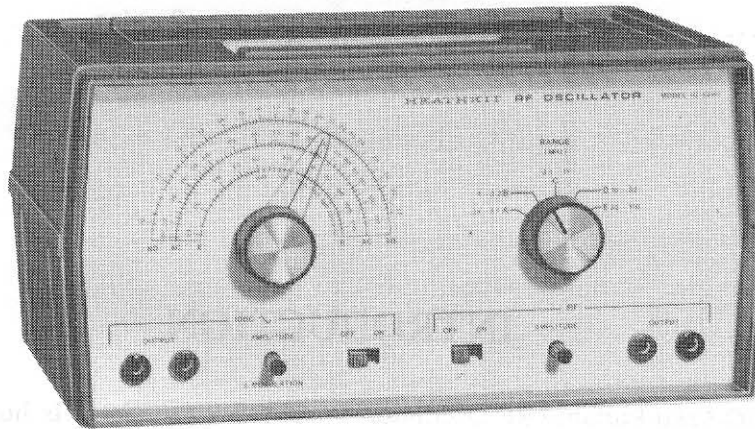

TABLE OF CONTENTS

RF OSCILLATOR

Model IG-5280

595-1957-04



The type of control knob is shown in the illustration. The Model IG-5280 RF Oscillator has a frequency range of 100 kHz to 10 MHz. The frequency scale is logarithmic and is marked in kHz, MHz, and GHz. The control knob is used to select the desired frequency. The oscillator is powered by a 9V battery. The output is taken from the output terminals. The oscillator is used for testing and for driving other electronic equipment.

HEATH COMPANY
BENTON HARBOR, MICHIGAN 49022

Copyright © 1977
Heath Company
All Rights Reserved
Printed in the United States of America



TABLE OF CONTENTS

Introduction	2	Applications	29
Parts List	3	In Case of Difficulty	31
Assembly Notes	6	Troubleshooting Chart	32
Step-by-Step Assembly	9	Specifications	33
Circuit Board Assembly	9	Circuit Description	34
Chassis Assembly	14	Circuit Board X-Ray View	35
Power Supply Switch and		Semiconductor Identification Chart	36
Connector Wiring	20	Schematic	(Illustration Booklet, Page 7)
Knob and Dial Pointer		Warranty	Inside Front Cover
Installation	22	Customer Service	Inside Rear Cover
Checkout	23		
Adjustments and Calibration	24		
Final Assembly	27		
Operation	28		

INTRODUCTION

The Heathkit Model IG-5280 Portable RF Oscillator provides AM modulated or un-modulated RF (radio frequency) signals. Five overlapping bands provide a wide range of frequencies covering the AM, FM, TV, LW, and SW broadcast bands. RF frequency is indicated on a large, easy-to-read dial scale. A continuously variable attenuator provides output signal levels that are suitable for most applications. A built-in 1000 Hz oscillator provides modulation for the RF signal and serves as a convenient source of audio signal.

To insure greater accuracy of the RF frequencies, the bandswitch and coil assembly has been assembled and adjusted at the factory. The completed RF Oscillator can be calibrated with a voltmeter and an AM-FM receiver.

This RF Oscillator is housed in the 5280-series instrument cabinet. This cabinet has a convenient storage compartment and is stackable. This will help you to lay out a neat "test center" arrangement. Each kit in this series is designed to operate from batteries as well as from an optional AC power supply.

The type 5280 series includes the Model IM-5284 Multimeter, the Model IPA-5280-1 Power Supply, and several other kits. If you have purchased the Multimeter, you may want to build it first so that it is available to check the other kits as you assemble them. You may want to build the power supply next to avoid the need for batteries.

BATTERIES

If you intend to operate on battery power you should purchase two 9-volt transistor batteries, NEDA #1604, at this time for use in your kit.

Representative manufacturers and their type numbers are:

Eveready #216, PP3
 Burgess #2U6
 Mallory #TR-146X (long life) M1604
 RCA #VS323
 Hellesens #410
 Varta #438
 CEI #6F22

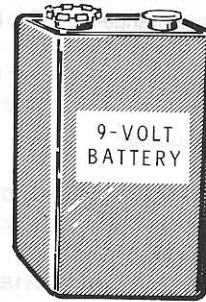

PARTS LIST

Check each part against the following list. The key numbers in the Parts List correspond to the numbers on the Parts Pictorial (Illustration Booklet, Page 1). Parts may vary slightly from the illustrations; only the hardware is shown actual size.

Some parts are packaged in containers with the part number marked on the outside. Except for the initial parts check, keep these parts in their containers so they can be easily identified when they are called for in the assembly steps.

Save all packaging material until all parts have been located.

Each circuit part in this kit has its own component number (R2, C4, etc.). Use these numbers to identify the same part in the various sections of the Manual.

These numbers, which are especially useful if a part has to be replaced, appear:

- In the Parts List,
- At the beginning of each step where a component is installed.
- In some illustrations,
- In the Schematic,
- In the sections at the rear of the Manual.

To order a replacement part, use the Parts Order Form furnished with this kit. If a Parts Order Form is not available, refer to "Replacement Parts" inside the rear cover of this Manual.



KEY No.	HEATH Part No.	QTY.	DESCRIPTION	CIRCUIT Comp. No.
---------	----------------	------	-------------	-------------------

KEY No.	HEATH Part No.	QTY.	DESCRIPTION	CIRCUIT Comp. No.
---------	----------------	------	-------------	-------------------

RESISTORS

CONTROLS — SWITCHES

1/2-Watt, 5%

NOTE: The following resistors have a tolerance of 5%. This is indicated by a fourth color band of gold. The resistors may be packed in more than one envelope.

A1	6-331	1	330 Ω (orange-orange-brown)	R7
A1	6-621	1	620 Ω (blue-red-brown)	R3
A1	6-332	2	3300 Ω (orange-orange-red)	R2, R8
A1	6-223	3	22 kΩ (red-red-orange)	R6, R11, R17
A1	6-333	1	33 kΩ (orange-orange-orange)	R4
A1	6-473	4	47 kΩ (yellow-violet-orange)	R10, R12, R14, R15
A1	6-683	2	68 kΩ (blue-gray-orange)	R1, R13
A1	6-104	1	100 kΩ (brown-black-yellow)	R18

C1	10-385	1	50 kΩ circuit board control	R19
C1	10-904	1	5000 Ω (5k) circuit board control	R5
C2	10-1017	1	1000 Ω (1k) control	R16
C2	10-1100	1	5000 Ω (5k) control	R9
C3	60-70	2	2-lug slide switch	SW2, SW3

TRANSISTORS

NOTE: Transistors are marked for identification in one of the following four ways:

1. Part number.
2. Type number.
3. Part number and type number.
4. Part number with a type number other than the one listed.

D1	417-235	1	2N4121	Q2
D1	417-291	1	2N5458	Q7
D1	417-293	1	2N5770	Q6
D1	417-801	3	MPSA20	Q3, Q4, Q5
D1	417-134	1	MPS6520	Q1

CAPACITORS

Ceramic

B1	21-3	3	10 pF	C3, C9, C18
B1	21-147	1	47 pF	C17
B1	21-9	1	100 pF	C7
B1	21-82	7	.02 μF	C5, C6, C8, C10, C11, C15, C19

CONNECTORS — JACKS — PLUG

E1	260-1	2	Alligator clip
E2	432-798	2	Battery connector
E3	436-11	2	Red banana jack/with hardware
E3	436-22	2	Black banana jack/with hardware
E4	438-47	2	Banana plug
E5	70-10	1	Black banana plug sleeve
E5	70-11	1	Red banana plug sleeve

Other Capacitors

B2	25-952	2	100 μF electrolytic	C20, C21
B3	26-57	1	356/165 pF, 2-section tuning	C13, C14
B4	27-141	1	.0027 μF (2700) Mylar*	C2
B4	27-136	1	.015 μF Mylar	C1
B5	28-1	1	2.2 pF phenolic (red-red-white)	C16
B6	31-56	1	2.5-20 pF trimmer	C12
B7	31-68	1	1.0-8.0 pF trimmer	C22

HARDWARE

NOTE: Hardware packets are marked to show the size of the hardware they contain (HDW #4, or, HDW #6 & #8, etc.). You may have to open more than one packet — in this pack — to locate all the hardware of any one size (#6, for example).

F1	250-138	4	6-32 × 3/16" screw
F2	250-56	11	6-32 × 1/4" screw
F3	250-592	2	#6 × 3/8" self tapping screw
F4	250-162	5	6-32 × 1/2" screw

*DuPont Registered Trademark

KEY HEATH QTY. DESCRIPTION
No. Part No. _____
CIRCUIT
Comp. No.

Hardware (cont'd.)

F5	252-3	7	6-32 nut
F6	252-195	5	6-32 self-retaining nut
F7	254-1	9	#6 lockwasher
F8	259-1	2	#6 solder lug
F9	250-15	1	8-32 x 1/8" setscrew
F10	250-22	2	8-32 x 7/16" setscrew
F11	252-7	1	3/8" nut
F12	253-10	1	3/8" flat washer
F13	254-5	1	3/8" lockwasher

LARGE PARTS

G1	92-662	1	Cabinet consisting of:
	92-659	1	Cabinet top
	92-660	1	Cabinet bottom
	92-661	1	Cabinet cover (assembled to top)
	92-668	1	Cover plate
G2	200-1290	1	Chassis
G3	203-1868-1	1	Front panel

WIRE

341-1	36"	Black test lead (stranded)
341-2	36"	Red test lead (stranded)
344-50	18"	Black wire
344-52	36"	Red wire
344-59	30"	White wire

KEY HEATH QTY. DESCRIPTION
No. Part No. _____
CIRCUIT
Comp. No.

MISCELLANEOUS

H1	56-616	1	5.6 V zener	ZD1
	85-2051-1	1	Circuit board	
H2	163-9	1	Rotary switch assembly with five coils (one coil is loose)	L1, L2, L3, L4, L5
H3	100-466	1	Dial pointer	
H4	462-207	1	Knob with pointer	
H5	462-140	1	Knob	
H6	490-1	1	Alignment tool	
H7	73-64	2	Foam strip	
	490-5	1	Nut starter	

Solder

PRINTED MATERIAL

		1	Assembly Manual (See Page 1 for part number)
	597-260	1	Parts Order Form
H8	391-34	1	Blue and white label

NOTE: Be sure you refer to the numbers on the blue and white label in any communications you may have about this kit with Heath Company. You may want to write the model and series numbers in this sample for future reference.



ASSEMBLY NOTES

TOOLS

You will need these tools to assemble your kit.

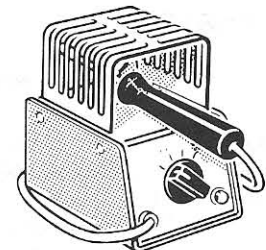
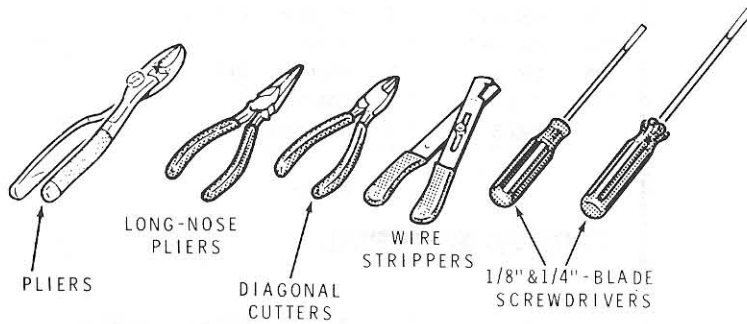

HEATHKIT
SOLDERING
IRON

OR

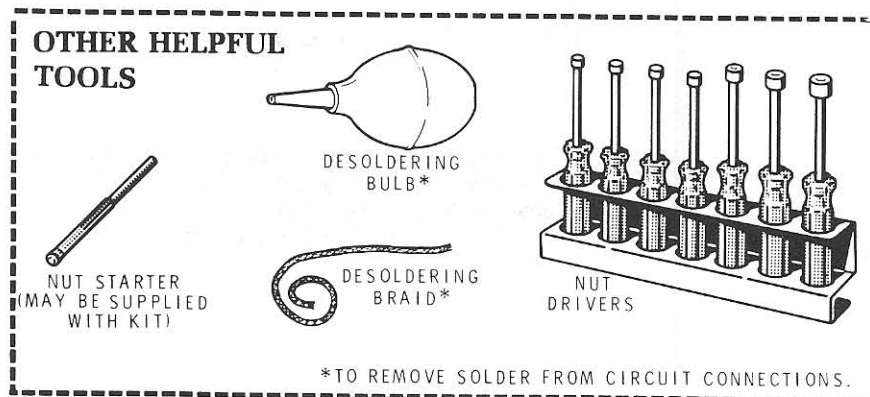
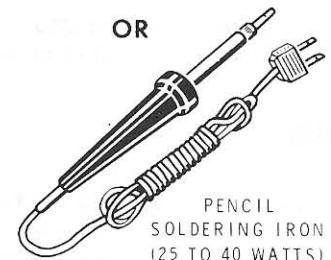

ASSEMBLY

1. Follow the instructions carefully and read the entire step before you perform the operation.
2. The illustrations in the Manual are called Pictorials and Details. Pictorials show the overall operation for a group of assembly steps; Details generally illustrate a single step. When you are directed to refer to a certain Pictorial "for the following steps," continue using that Pictorial until you are referred to another Pictorial for another group of steps.
3. Most kits use a separate "Illustration Booklet" that contains illustrations (Pictorials, Details, etc.) that are too large for the Assembly Manual. Keep the "Illustration Booklet" with the Assembly Manual. The illustrations in it are arranged in Pictorial number sequence.
4. Position all parts as shown in the Pictorials.
5. Solder a part or a group of parts only when you are instructed to do so.

6. When you are instructed to cut something to a particular length, use the scales (rulers) provided at the bottom of the Manual pages.

SAFETY WARNING: Avoid eye injury when you cut off excess lead lengths. Hold the leads so they cannot fly toward your eyes.

SOLDERING

Soldering is one of the most important operations you will perform while assembling your kit. A good solder connection will form an electrical connection between two parts, such as a component lead and a circuit board foil. A bad solder connection could prevent an otherwise well-assembled kit from operating properly.

It is easy to make a good solder connection if you follow a few simple rules:

1. Use the right type of soldering iron. A 25 to 40-watt pencil soldering iron with a 1/8" or 3/16" chisel or pyramid tip works best.
2. Keep the soldering iron tip clean. Wipe it often on a wet sponge or cloth; then apply solder to the tip to give the entire tip a wet look. This process is called tinning, and it will protect the tip and enable you to make good connections. When solder tends to "ball" or does not stick to the tip, the tip needs to be cleaned and retinned.

RESISTORS

Resistors are identified in Parts Lists and steps by their resistance value in Ω (ohms), $k\Omega$ (kilohms), or $M\Omega$ (megohms). They are usually identified by a color code of four or five color bands, where each color represents a number. See the "Resistor Color Code" chart. These colors are given in the steps in their proper order (except for the last band, which indicates a resistor's "tolerance"; see the "Resistor Tolerance Chart"). You do not need to memorize the color codes.

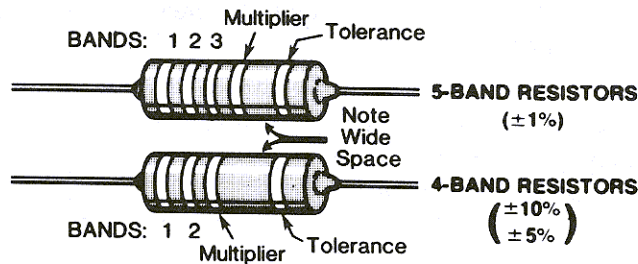

Occasionally, a "precision" or "power" resistor may have the value stamped on it. The letter R, K, or M may also be used at times to signify a decimal point, as in:

2R2 = 2.2 Ω
 2K2 = 2.2 $k\Omega$, or 2200 Ω
 2M2 = 2.2 $M\Omega$

Precision resistors may also be marked as shown in the following examples. The values of the multipliers are shown in the "Multiplier Chart," and the tolerance values are shown in the "Resistor Tolerance" chart.

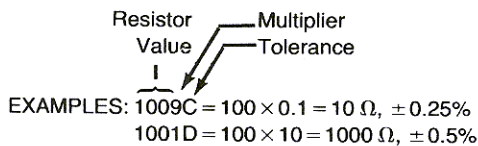

CAPACITORS

Capacitors will be called out by their capacitance value in μF (microfarads) or pF (picofarads) and type: ceramic, Mylar®, electrolytic, etc. Some capacitors may have their value printed in the following manner:

First and second digits of capacitor's value: 15

Multiplier: Multiply the first & second digits by the proper value from the "Multiplier Chart."

To find the tolerance of the capacitor, look up this letter in the capacitor Tolerance chart.

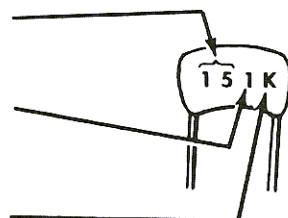

RESISTOR COLOR CODE CHART

	Band 1	Band 2	Band 3 (if used)	Multiplier
Color	1st Digit	2nd Digit	3rd Digit	
Black	0	0	0	1
Brown	1	1	1	10
Red	2	2	2	100
Orange	3	3	3	1,000
Yellow	4	4	4	10,000
Green	5	5	5	100,000
Blue	6	6	6	1,000,000
Violet	7	7	7	10,000,000
Gray	8	8	8	100,000,000
White	9	9	9	—
Silver	—	—	—	.01
Gold	—	—	—	.1

RESISTOR TOLERANCE CHART

	COLOR OR LETTER	
$\pm 10\%$	SILVER	
$\pm 5\%$	GOLD	J
$\pm 2\%$	RED	G
$\pm 1\%$	BROWN	F
$\pm 0.5\%$	GREEN	D
$\pm 0.25\%$	BLUE	C
$\pm 0.1\%$	VIOLET	B
$\pm 0.05\%$	GRAY	

MULTIPLIER CHART

FOR THE NUMBER:	MULTIPLY BY:	FOR THE NUMBER:	MULTIPLY BY:
0	1	4	10,000
1	10	5	100,000
2	100	8	0.01
3	1000	9	0.1

CAPACITOR TOLERANCE CHART

LETTER	10 pF OR LESS	OVER 10 pF
B	$\pm 0.1 pF$	
C	$\pm 0.25 pF$	
D	$\pm 0.5 pF$	
F	$\pm 1.0 pF$	$\pm 1\%$
G	$\pm 2.0 pF$	$\pm 2\%$
H		$\pm 3\%$
J		$\pm 5\%$
K		$\pm 10\%$
M		$\pm 20\%$

EXAMPLES: 151K = $15 \times 10 = 150 pF$
 759 = $75 \times 0.1 = 7.5 pF$

NOTE: The letter "R" may be used at times to signify a decimal point, as in: 2R2 = 2.2 (pF or μF).

STEP-BY-STEP ASSEMBLY

CIRCUIT BOARD ASSEMBLY

START

In the following steps, you will be given detailed instructions on how to install and solder the first part on the circuit board. Read and perform each step carefully. Then use the same procedure whenever you install parts on a circuit board.

() Position the circuit board as shown with the printed side (not the foil side) up.

() R15: Hold a 47 kΩ (yellow-violet-orange) resistor by the body as shown and bend the leads straight down.

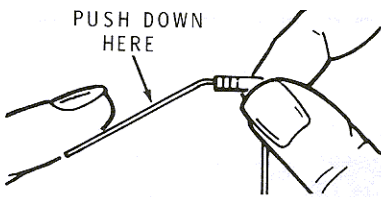

() Push the leads through the holes at the indicated location on the circuit board. The end with color bands may be positioned either way.

() Press the resistor against the circuit board. Then bend the leads outward slightly to hold the resistor in place.

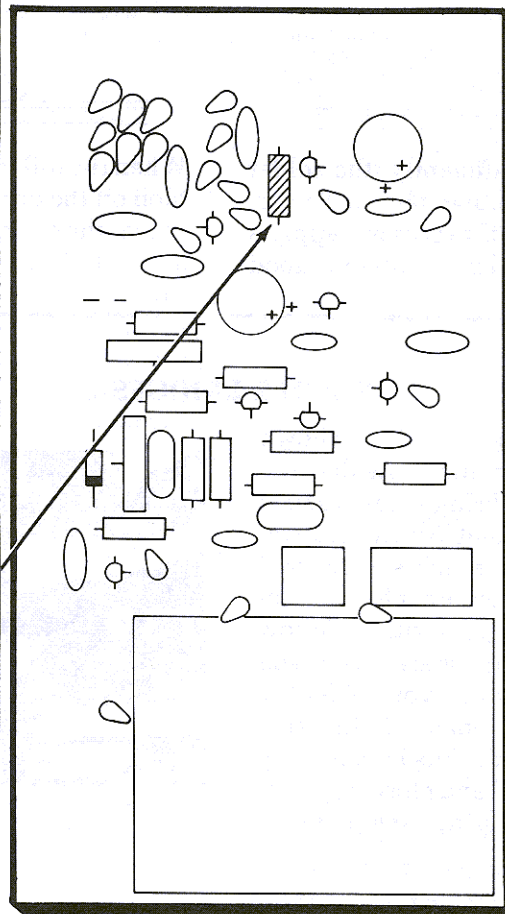
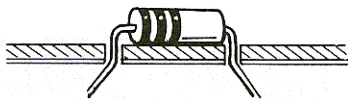

PICTORIAL 1

CONTINUE

() Solder the resistor leads to the circuit board as follows:

1. Push the soldering iron tip against both the lead and the circuit board foil. Heat **both** for two or three seconds.

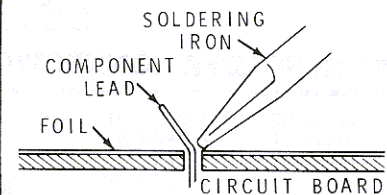

2. Then apply solder to the other side of the connection. **IMPORTANT:** Let the heated lead and the circuit board foil melt the solder.

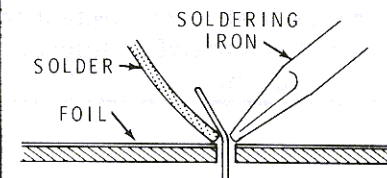

3. As the solder begins to melt, allow it to flow around the connection. Then remove the solder and the iron and let the connection cool.

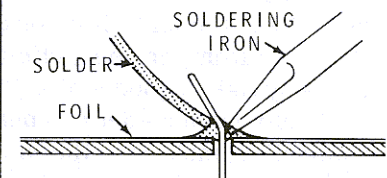

() Cut off the excess lead lengths close to the connection. **WARNING:** Clip the leads so the ends will not fly toward your eyes.

() Check each connection. Compare it to the illustrations on Page 10. After you have checked the solder connections, proceed with the assembly on Page 11. Use the same soldering procedure for each connection.

A GOOD SOLDER CONNECTION

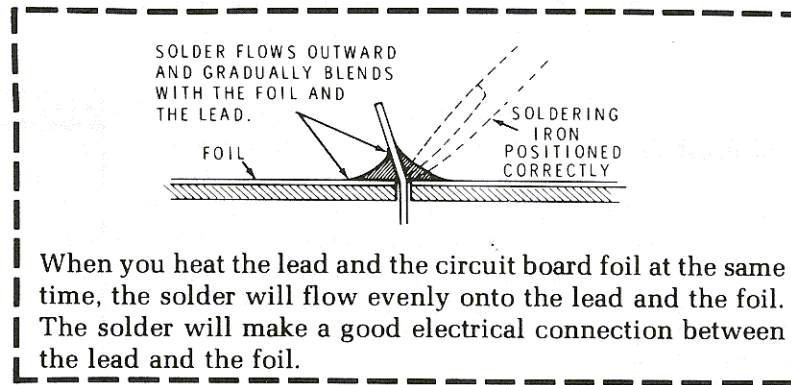

POOR SOLDER CONNECTIONS

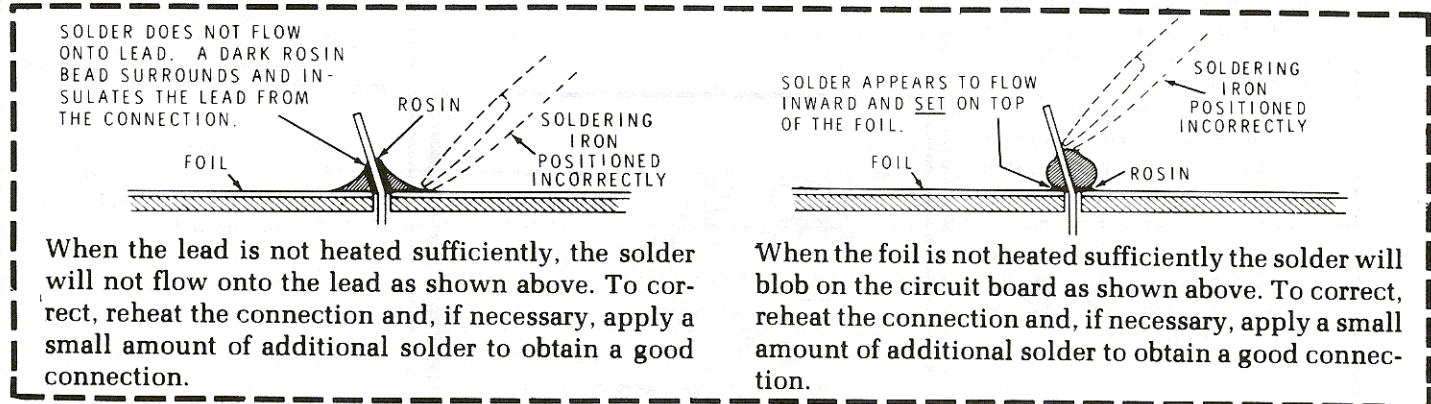

SOLDER BRIDGES

A solder bridge between two adjacent foils is shown in photograph A. Photograph B shows how the connection should appear. A solder bridge may occur if you accidentally touch an adjacent previously soldered connection, if you use too much solder, or if you "drag" the soldering iron across other foils as you remove it from the connection. A good rule to follow is; always take a good look at the foil area around each lead before you solder it. Then, when you solder the connection, make sure the solder remains in this area and does not bridge to another foil. This is especially important when the foils are small and close together. NOTE: It is alright for solder to bridge two connections on the same foil.

Use only enough solder to make a good connection, and lift the soldering iron straight up from the circuit board. If a solder bridge should develop, turn the circuit board foil-side-down and heat the solder between connections. The excess solder will run onto the tip of the soldering iron, and this will remove the solder bridge. NOTE: The foil side of each circuit board has a coating on it called "solder resist." This is a protective insulation to help prevent solder bridges.

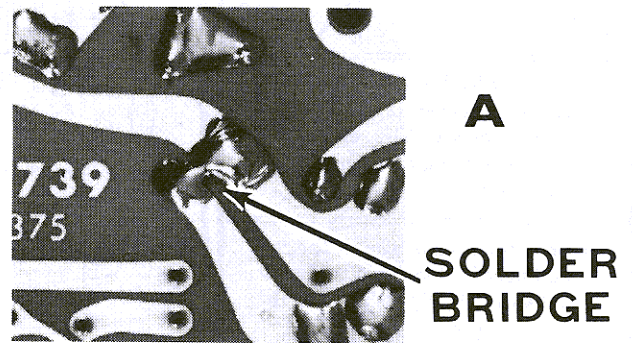

START ↘

- () Position the circuit board as shown with its printed side up. Then complete the following steps.
- () Cut a 3/4" small red wire and remove all of the insulation. Install this bare wire in the next step.
- () 3/4" bare wire. Solder the wire to the foils and cut off the excess lengths.
- () R6: 22 kΩ (red-red-orange).
- () R8: 3300 Ω (orange-orange-red).
- () R7: 330 Ω (orange-orange-brown).
- () R3: 620 Ω (blue-red-brown).
- () Solder the leads to the foil and cut off the excess lead lengths.
- () R1: 68 kΩ (blue-gray-orange).
- () R17: 22 kΩ (red-red-orange).
- () R4: 33 kΩ (orange-orange-orange).
- () R2: 3300 Ω (orange-orange-red).
- () R18: 100 kΩ (brown-black-yellow).
- () Solder the leads to the foil and cut off the excess lead lengths.

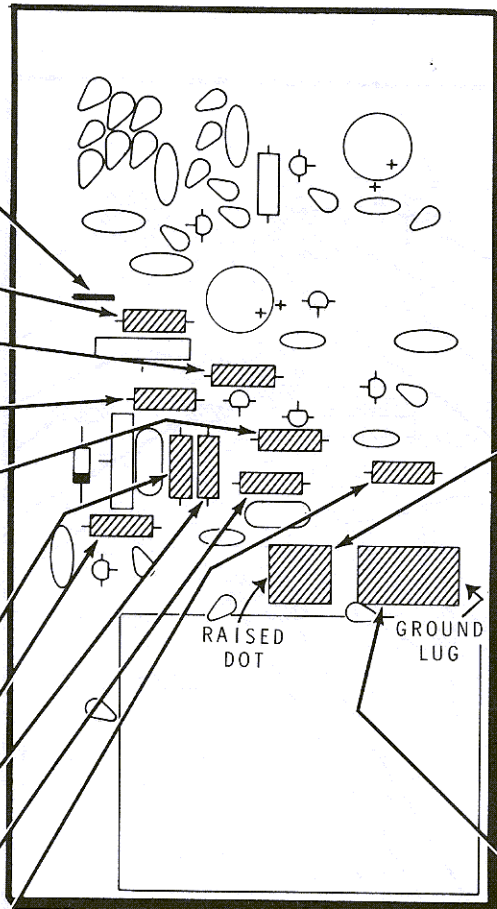

CONTINUE ↘

- () C22: 1-8 pF trimmer. Insert the lugs into the circuit board and solder them to the foil. Position the raised dot as shown.
- () C12: 1.5-20 pF trimmer. IT IS VERY IMPORTANT to solder the correct trimmer lug to the correct foil. One trimmer lug will be called the ground lug. This is the lug that is connected to the metal plate directly under the screw on the trimmer.

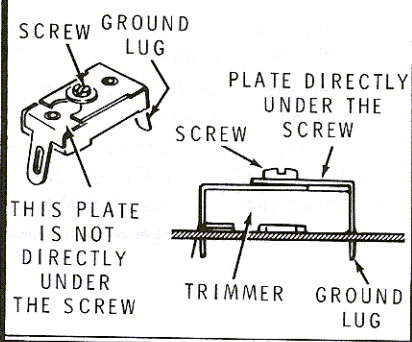
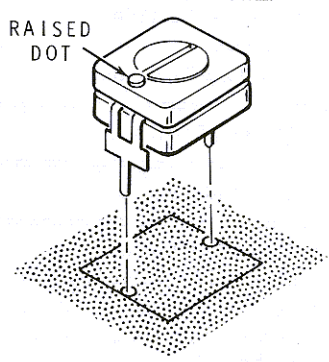

- () Solder the trimmer lugs to the foil.

PICTORIAL 2



START ↓

NOTE: A coating on ceramic and Mylar capacitor leads can extend through the circuit board and make soldering difficult. Therefore, always space ceramic and Mylar capacitors 1/16" off the circuit board.

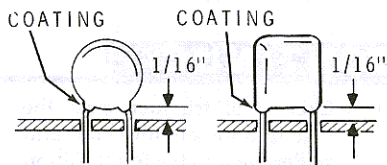

- () C8: .02 μ F ceramic.
 - () C10: .02 μ F ceramic.
 - () C7: 100 pF ceramic.
 - () C5: .02 μ F ceramic.
 - () C1: .015 μ F Mylar.
 - () ZD1: 5.6 V zener (#56-616). Be sure to position the banded end as shown.
-
- () C15: .02 μ F ceramic.
 - () C18: 10 pF ceramic.
 - () C2: .0027 μ F Mylar.
 - () Solder the leads to the foil and cut off the excess lead lengths.

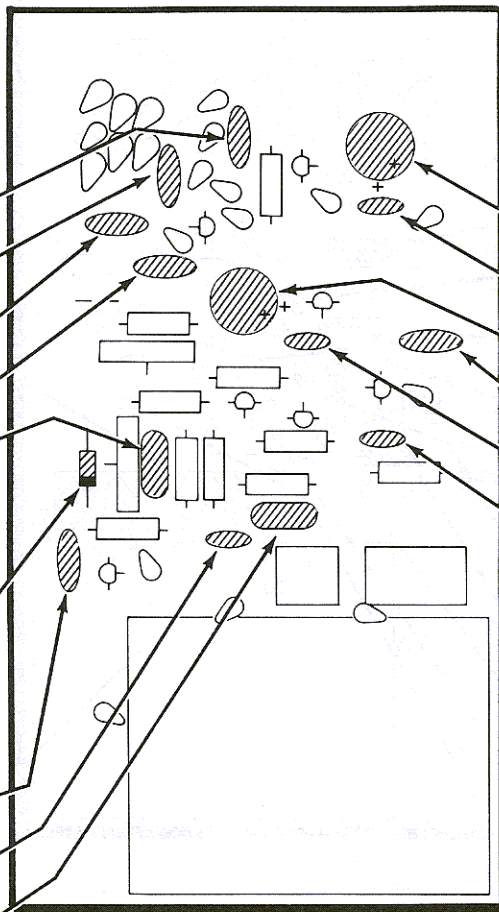

PICTORIAL 3

CONTINUE ↓

NOTE: Before you install an electrolytic capacitor, look at it and identify the leads. One lead will have either a negative (-) mark or a positive (+) mark near it on the side of the capacitor. See Detail 3A. (The marking for a negative lead may look like an oblong bar, sometimes with a circle around it, inside an arrow.) . . . Be sure to install the positive lead in the positive-marked hole, and the negative lead in the other hole.

- () C20: 100 μ F electrolytic.
- () C9: 10 pF ceramic.
- () C21: 100 μ F electrolytic.
- () C19: .02 μ F ceramic.
- () C3: 10 pF ceramic.
- () C17: 47 pF ceramic.
- () Solder the leads to the foil and cut off the excess lead lengths.

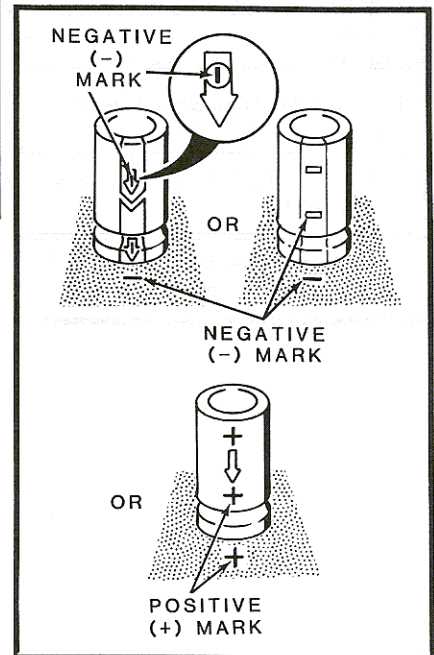

Detail 3A

START ▾

NOTE: Install the following transistors as shown. First line up the flat on each transistor with the outline of the flat on the circuit board. Then insert the E, B, and C leads into their correct holes. Solder the leads to the foil and cut off the excess lead lengths.

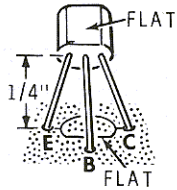

() Q5: MPSA20 transistor (#417-801).

() Q4: MPSA20 transistor (#417-801).

() Q3: MPSA20 transistor (#417-801).

() Q1: MPS6520 transistor (#417-134).

NOTE: The following transistor may be supplied in one of two styles. Identify the E, B, and C leads of the transistor. Then insert the E, B, and C leads into the corresponding E, B, and C holes in the circuit board. Position the transistor 1/4" above the circuit board. Solder the leads to the foil and cut off the excess lead lengths.

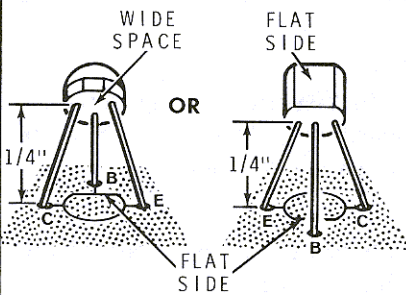

() Q6: 2N5770 transistor (#417-293).

() Q2: 2N4121 transistor (#417-235).

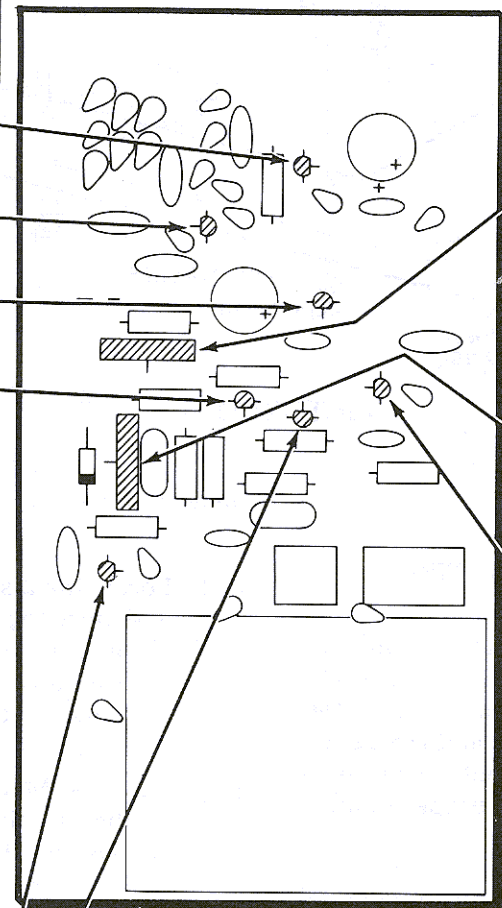

CONTINUE ▾

() R5: 5 kΩ (5000) control (#10-904). Seat the control firmly against the circuit board and solder the lugs to the foil.

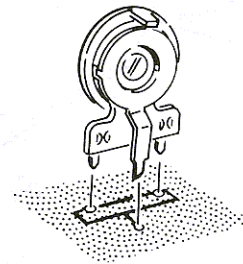

() R19: 50 kΩ control (#10-385). Solder the lugs to the foil.

() Q7: 2N5458 transistor (#417-291). Line up the flat of the transistor with the outline of the flat on the circuit board. Then insert the D, S, and G leads into their correct holes. Solder the leads to the foil and cut off the excess lead lengths.

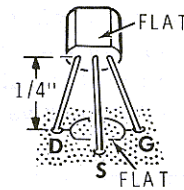

PICTORIAL 4

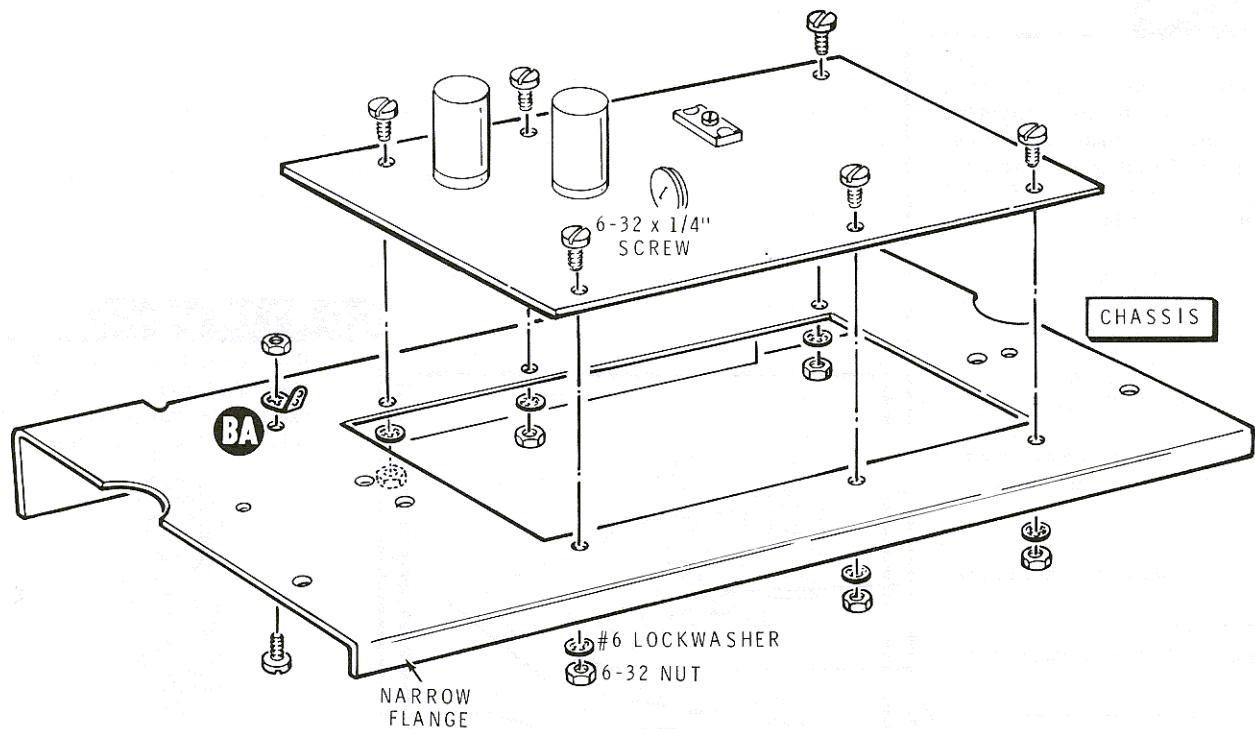

PICTORIAL 5

CHASSIS ASSEMBLY

Refer to Pictorial 5 for the following steps.

NOTE: When hardware is called for in a step, only the screw size will be given. For instance, if "6-32 × 1/4" hardware" is called for, it means that a 6-32 × 1/4" screw, one or more #6 lockwashers, and a 6-32 nut should be used for each mounting hole. The Detail referred to in the step will show the proper number and placement of lockwashers.

Use the plastic nut starter supplied with this kit to hold and start 6-32 nuts on screws.

- () Locate the chassis and position it as shown. The side of the chassis with the wider flange is the front. The narrow flange is across the rear of the chassis.
- () Mount a #6 solder lug at BA with 6-32 × 1/4" hardware. Position the lug as shown.
- () Mount the circuit board to the top of the chassis. Use 6-32 × 1/4" hardware.

Refer to Pictorial 6 for the following steps.

- () Locate the 2-section tuning capacitor (#26-57) and turn the shaft counterclockwise to fully close the plates. Keep the plates in this position to minimize the chance of damage to the capacitor plates.
- () C13/C14: Mount the 2-section tuning capacitor to the circuit board with three 6-32 × 3/16" screws and three #6 lockwashers.
- () Cut two 1-1/4" red wires. Remove all of the insulation from both wires.

NOTE: In the following steps, (NS) means not to solder the connection because other wires will be added later. (S-) with a number such as (S-3) means to solder the connection. The number following the "S" tells how many wires are in the connection.

- () Connect a 1-1/4" bare wire between tuning capacitor C13/C14 lug 1 (S-1) and hole N on the circuit board (S-1).

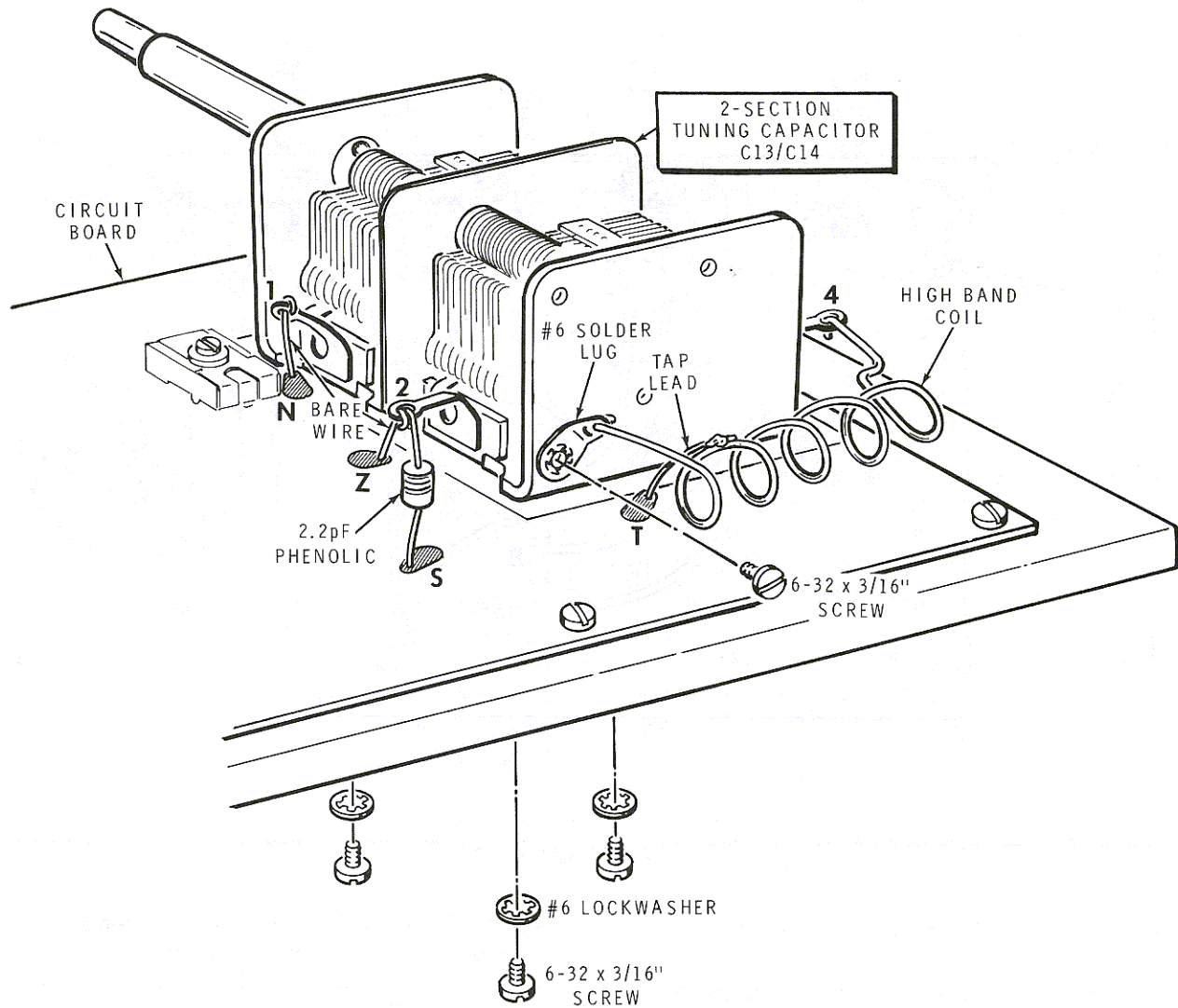

PICTORIAL 6

- () Connect the other 1-1/4" bare wire between tuning capacitor C13/C14 lug 2 (NS) and hole Z on the circuit board (S-1).
- () C16: Connect the 2.2 pF (red-red-white) phenolic capacitor between tuning capacitor C13/C14 lug 2 (S-2) and hole S on the circuit board (S-1).
- () Be sure to cut off the excess lead lengths.
- () Mount a #6 solder lug to the back of tuning capacitor C13/C14 as shown, with a 6-32 x 3/16" screw. Position the solder lug as shown.
- () Locate the preformed high band coil packed with the rotary switch. Do not bend or distort this coil. It has been preformed at the factory for the correct value. You can bend the tap lead as necessary.
- () L5: Connect the high band coil to tuning capacitor C13/C14 between the solder lug on the back of the tuning capacitor (S-1) and lug 4 (S-1). Connect the tap lead coming from the coil to hole T on the circuit board (S-1). Make sure the tap lead does not touch the tuning capacitor.

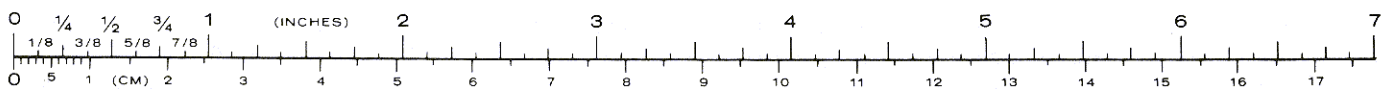

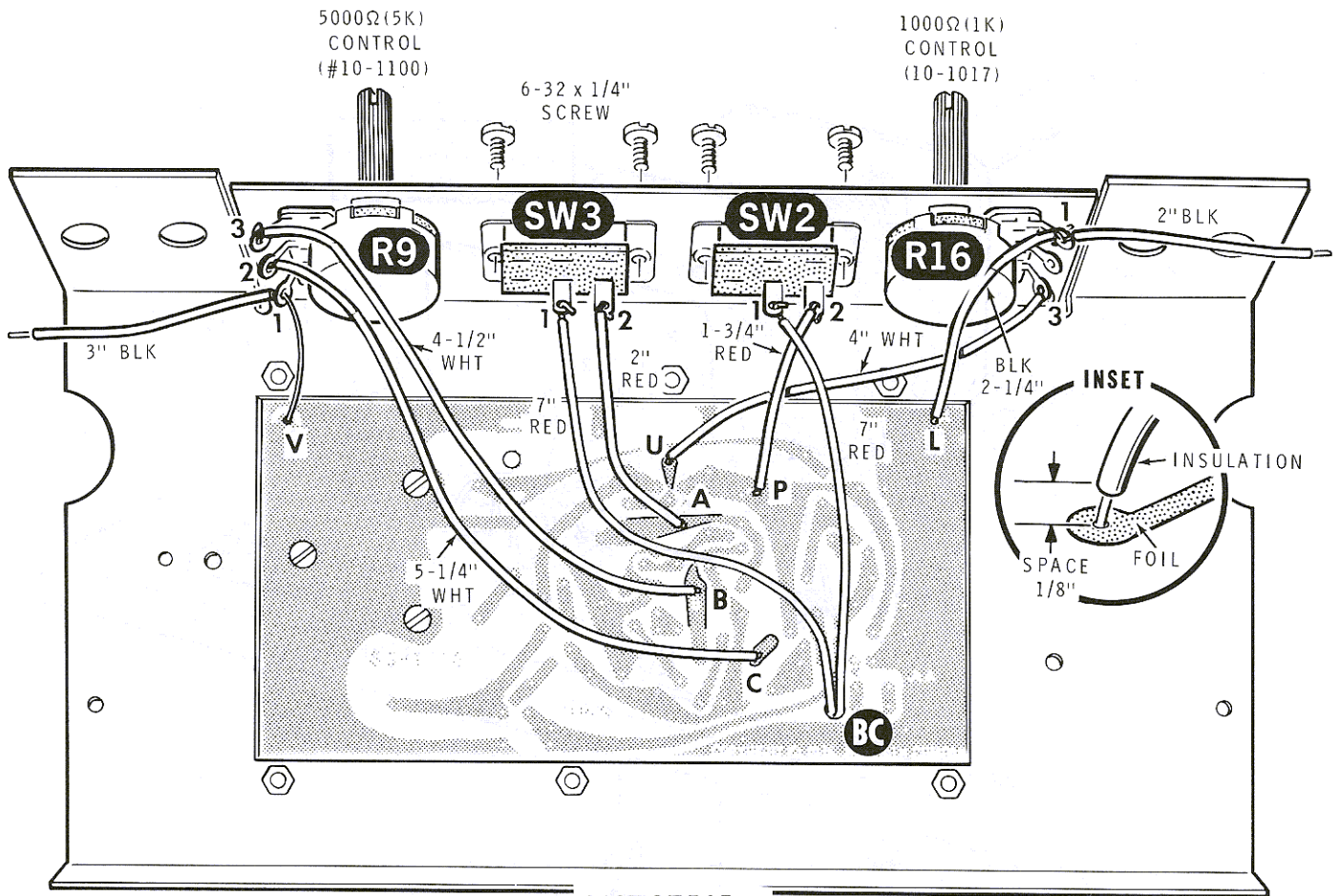

PICTORIAL 7

Refer to Pictorial 7 for the following steps.

- () Position the chassis bottom side up as shown.
- () SW2: Mount a 2-lug slide switch at SW2 on the chassis. Use 6-32 x 1/4" screws. Be sure to position the switch lugs as shown.
- () SW3: In the same manner, mount a 2-lug slide switch at SW3.
- () R9: Refer to Detail 7-A and install a 5000 Ω (5k) control at R9. Insert the control tabs through the chassis. Then bend the tabs over. Be sure to position the control lugs as shown.
- () R16: In the same manner, install a 1000 Ω (1k) control at R16. Be sure to position the control lugs as shown.

NOTE: When you are instructed to prepare wire as in the next step, cut the wire to the indicated length and remove 1/4" of insulation from each end. The wires are listed in the order in which they will be used.

- () Prepare the following wires:

4"	white
2-1/4"	black
2"	black
1-3/4"	red
7"	red
2"	red
7"	red
3"	black
5-1/4"	white
4-1/2"	white

NOTE: When you connect a wire to the foil side of the circuit board as in the next step, position the insulation on the wire up off the foil so the solder can flow in around the bare wire and form a good connection. See inset drawing.

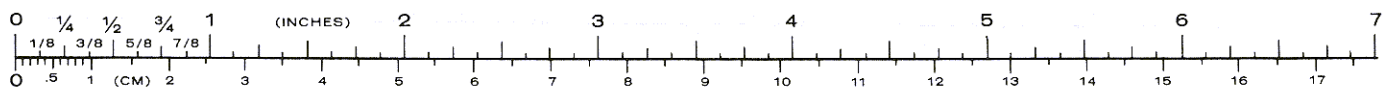

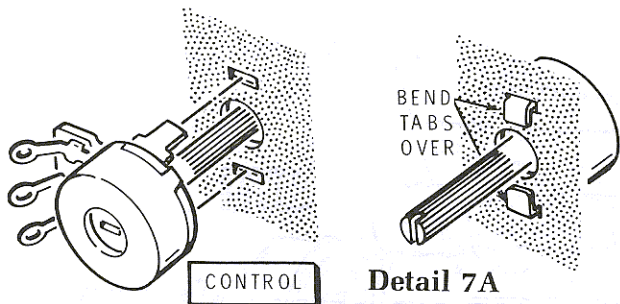

- () Connect a 4" white wire between control R16 lug 3 (S-1) and hole U on the circuit board (S-1).
- () Connect a 2-1/4" black wire between control R16 lug 1 (NS) and hole L on the circuit board (S-1).
- () Connect one end of a 2" black wire to control R16 lug 1 (S-2). The other end of this wire will be connected later.
- () Connect a 1-3/4" red wire between switch SW2 lug 2 (S-1) and hole P on the circuit board (S-1).
- () Connect one end of a 7" red wire to switch SW2 lug 1 (S-1). Route the other end of this wire through hole BC.
- () Connect a 2" red wire between switch SW3 lug 2 (S-1) and hole A on the circuit board (S-1).
- () Connect one end of a 7" red wire to switch SW3 lug 1 (S-1). Route the other end of this wire through hole BC.
- () Remove an additional 1/2" (3/4" total) of insulation from one end of the 3" black wire. Then insert this bare end through control R9 lug 1 and connect it to hole V on the circuit board. Solder hole V and lug 1. The other end of this wire will be connected later.

- () Connect a 5-1/4" white wire between control R9 lug 2 (NS) and hole C on the circuit board (S-1).
- () Connect a 4-1/2" white wire between control R9 lug 3 (S-1) and hole B on the circuit board (S-1).

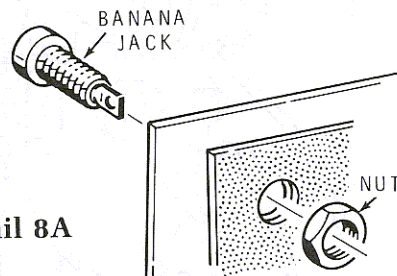

Detail 8A

Refer to Pictorial 8 for the following steps.

- () Refer to Detail 8A and mount the front panel to the chassis with two red banana jacks and two black banana jacks. Use the hardware supplied on the banana jacks. Be sure to install the red and black jacks as shown.
- () Connect the black wire coming from control R9 lug 1 to the black banana jack (S-1).
- () C6: Connect a .02 uF ceramic capacitor between control R9 lug 2 (S-2) and the red banana jack (S-1). Keep the leads short.
- () Connect the black wire coming from control R16 lug 1 to the black banana jack (S-1).
- () C11: Connect a .02 uF ceramic capacitor between control R16 lug 2 (S-1) and the red banana jack (S-1). Keep the leads short.
- () Set the chassis aside temporarily.

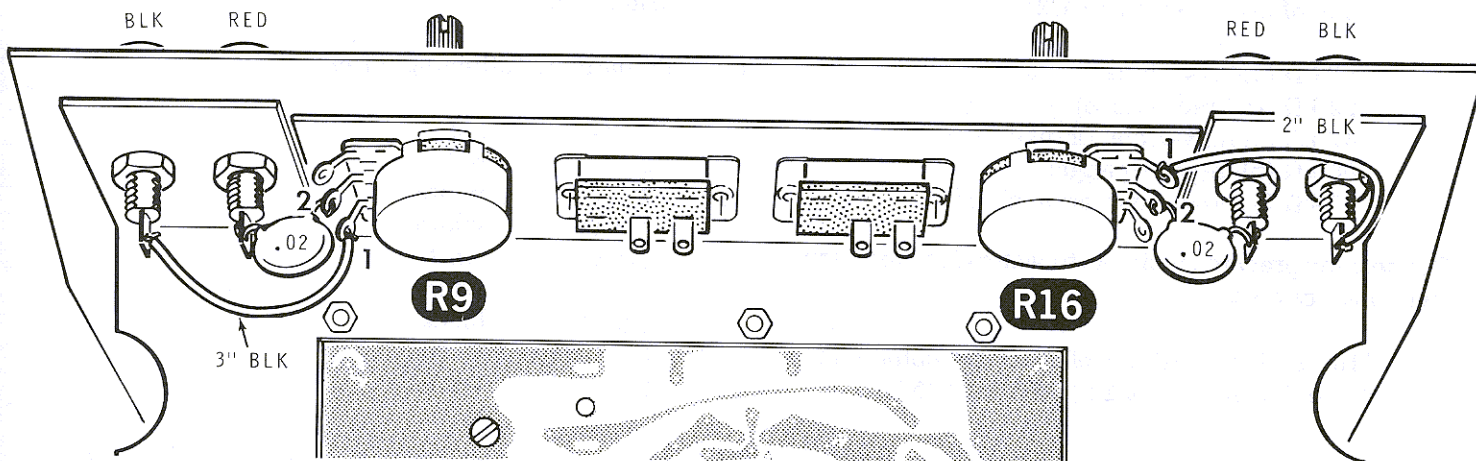

PICTORIAL 8

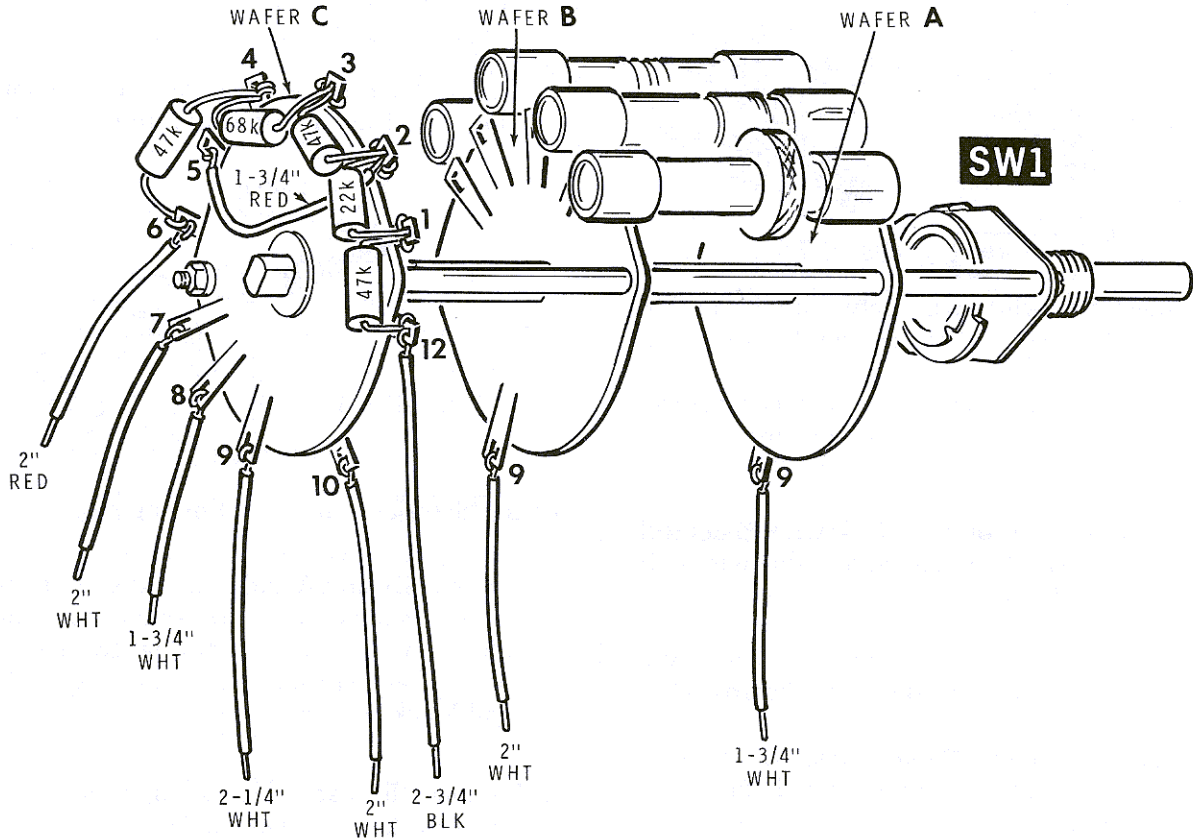

PICTORIAL 9

Refer to Pictorial 9 for the following steps.

- () Locate the rotary switch (SW1) and position it as shown. Be very careful not to damage any of the coils on the switch.

NOTE: There is a bare wire extending from lug 6 on the front wafer of the switch. Do not cut this wire off. It will be connected later.

- () Locate the following resistors and cut both leads of each resistor to 1/2".

- 47 kΩ (yellow-violet-orange)
- 22 kΩ (red-red-orange)
- 47 kΩ (yellow-violet-orange)
- 68 kΩ (blue-gray-orange)
- 47 kΩ (yellow-violet-orange)

Connect the prepared resistors to wafer C of the rotary switch as follows:

- () R10: 47 kΩ resistor (refer to the color code above) between lugs 12 (NS) and 1 (NS).

- () R11: 22 kΩ resistor between lugs 1 (S-2) and 2 (NS).
- () R12: 47 kΩ resistor between lugs 2 (NS) and 3 (NS).
- () R13: 68 kΩ resistor between lugs 3 (S-2) and 4 (NS).
- () R14: 47 kΩ resistor between lugs 4 (S-2) and 6 (NS). NOTE: Do not connect the one resistor lead to lug 5 by mistake.
- () Prepare the following wires:

- 1-3/4" red
- 2" red
- 2" white
- 1-3/4" white
- 2-1/4" white
- 2" white
- 2-3/4" black
- 2" white
- 1-3/4" white



Connect the following wires to wafer C of the rotary switch. In most cases, only one end of each wire will be connected at this time.

- 1-3/4" red wire between lugs 2 (S-3) and 5 (S-1).
- One end of a 2" red wire to lug 6 (S-2).
- One end of a 2" white wire to lug 7 (S-1).
- One end of a 1-3/4" white wire to lug 8 (S-1).
- One end of a 2-1/4" white wire to lug 9 (S-1).
- One end of a 2" white wire to lug 10 (S-1).
- One end of a 2-3/4" black wire to lug 12 (S-2).
- Connect one end of a 2" white wire to wafer B lug 9 (S-1).
- Connect one end of a 1-3/4" white wire to wafer A lug 9 (S-1).

Refer to Pictorial 10 (Illustration Booklet, Page 2) for the following steps.

- Position the chassis right side up as shown.
- SW1: Refer to Detail 10A and install the rotary switch into the front panel at BB. Use a 3/8" lockwasher, a 3/8" flat washer, and a 3/8" nut. Do not tighten the hardware.
- Rotate the rotary switch so the bare wire coming from lug 6 on the front wafer can be inserted through solder lug BA. Then position the switch so lugs 1 and 12 are up. Tighten the switch hardware.
- Pull the bare wire through solder lug BA and solder it to the lug. Cut off any excess length.

Connect the wires coming from the rotary switch wafer C to the circuit board as follows:

- Red wire coming from lug 6 to hole F (S-1).
- White wire coming from lug 7 to hole H (S-1).
- White wire coming from lug 8 to hole R (S-1).

- White wire coming from lug 9 to hole J (S-1).
- White wire coming from lug 10 to hole D (S-1).
- Black wire coming from lug 12 to hole E (S-1).
- Connect the white wire coming from wafer B lug 9 to hole G (S-1).
- Connect the white wire coming from wafer A lug 9 to hole K (S-1).

Refer to Detail 10B (Illustration Booklet, Page 3) and connect one of the battery connectors to the circuit board as follows:

- Red wire to hole AB (S-1).
- Black wire to hole AC (S-1).

Connect the other battery connector to the circuit board as follows:

- Red wire to hole AE (S-1).
- Black wire to hole AF (S-1).
- Carefully peel the paper backing from the blue and white label and press the label into place on the inside of the front panel. Make sure you refer to the numbers on the label in any communications you have with the Heath Company about this kit.
- Refer to Pictorial 11 (in the Illustration Booklet) and prepare two test leads. Use the black and red test leads (stranded wire).

NOTE: If you purchased the AC Power Supply, disregard the next two steps and proceed to "Power Supply Switch and Connector Wiring" on Page 20. If you are going to use battery power ONLY, perform the next two steps and then proceed to "Knob and Dial Pointer Installation" on Page 22. You will need the leftover black and red wires to modify your unit if you purchase the AC Power Supply later.

Refer to Detail 10C for the next two steps.

- Connect the wire coming from SW2 lug 1 to circuit board hole AA (S-1).
- Connect the wire coming from SW3 lug 1 to circuit board hole AD (S-1).

POWER SUPPLY SWITCH AND CONNECTOR WIRING

NOTE: When you complete the following steps, your unit will work with batteries as well as with the AC power supply.

Remove the following parts from the AC power supply kit. Use these parts in the following steps.

Quantity	Description
1	Female connector shell
2	Male connector pin
1	6-lug slide switch
1	2.9 mH choke (#45-81)
1	Mounting plate
2	6-32 × 1/4" screws

() Prepare the following wires:

4"	black
4"	red
4"	red
1-3/4"	red

Refer to Pictorial 12 for the following steps.

() Position the chassis as shown.

NOTE: The other end of the next three wires will be connected later.

- () Connect one end of a 4" black wire to circuit board hole X (S-1).
- () Connect one end of a 4" red wire to circuit board hole AA (S-1).
- () Connect one end of a 4" red wire to circuit board hole AD (S-1).
- () Locate the 6-lug slide switch and the 2.9 mH choke.
- () Cut both leads of the 2.9 mH choke to 3/4".

NOTE: In the next step, it does not matter which way the switch is positioned.

- () L6: Connect the 2.9 mH choke between lugs 3 (NS) and 6 (S-1) of the switch.
- () Refer to Detail 12A, Part A and crimp and solder a male connector pin onto one end of a 1-3/4" red wire.

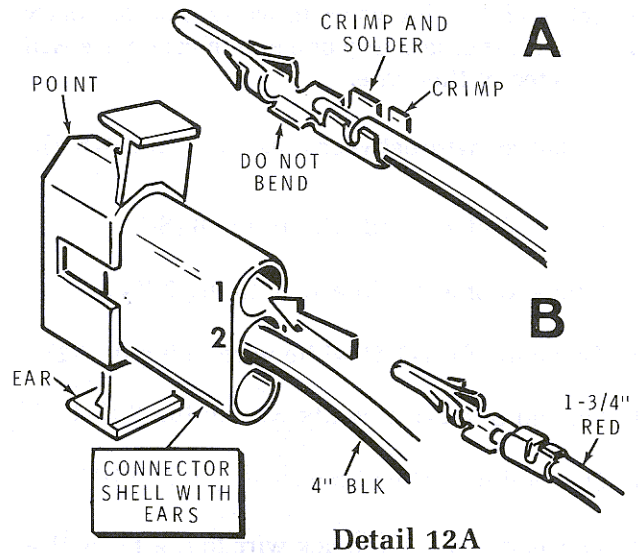

- () Connect the other end of this same wire to switch SW4 lug 3 (S-2).
- () In the same manner, crimp and solder a male connector pin onto the free end of the black wire coming from hole X on the circuit board.

NOTE: In the next two steps, the connector pins will "click" as they lock into place.

- () Refer to Detail 12A, Part B and insert the connector pin on the red wire into the female connector shell, hole 1. NOTE: The hole numbers are stamped in the back part of the connector.
- () In the same manner, insert the connector pin on the black wire into hole 2 of the female connector shell.
- () Gently pull on both of the wires that you just installed. If the pins pull out of the connector shell, push them back in until they "lock" in place.
- () Connect the red wire coming from hole AA on the circuit board to SW4 lug 4 (S-1).
- () Connect the red wire coming from hole AD on the circuit board to SW4 lug 1 (S-1).
- () Connect the red wire coming from SW2 to SW4 lug 5 (S-1). Make sure you do not connect the wire coming from switch SW3 by mistake.
- () Connect the red wire coming from SW3 to SW4 lug 2 (S-1).

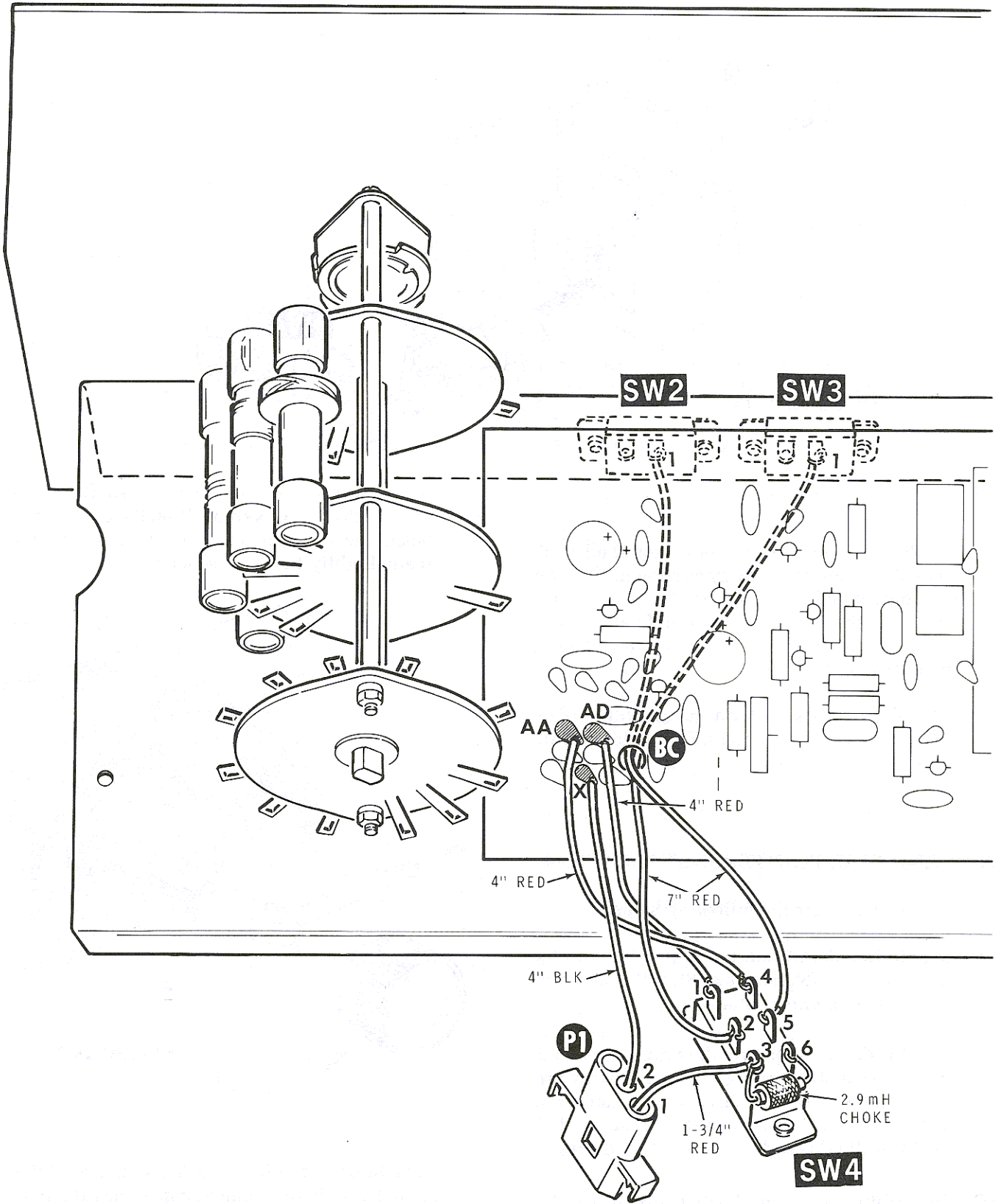

PICTORIAL 12

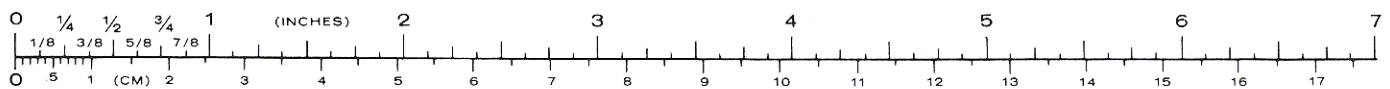

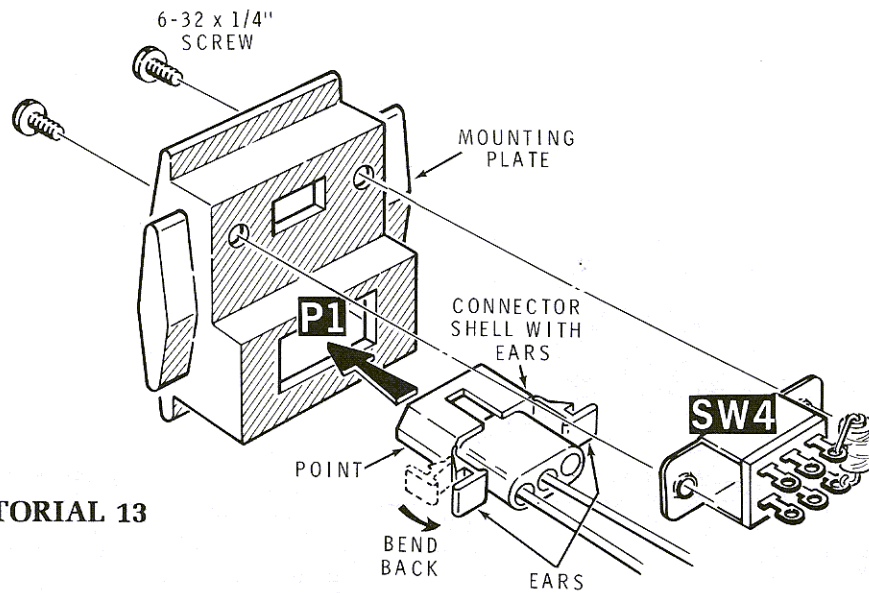

PICTORIAL 13

Refer to Pictorial 13 for the following steps.

- () P1: Bend the ears of the connector shell back against the side of the body as shown. Position the pointed end as shown. Push the connector shell into the mounting plate hole at P1. The ears of the connector shell will lock into place at the edges of the hole.
- () SW4: Install the switch on the mounting plate with two 6-32 \times 1/4" screws. Be sure to position the switch lugs as shown.

- () Make sure the tuning capacitor shaft is fully counterclockwise, and position the dial pointer black line a little below the left end of the dial scale. Lightly tighten the setscrew.

KNOB AND DIAL POINTER INSTALLATION

Refer to Pictorial 14 for the following steps.

- () Refer to Detail 14A and locate the dial pointer and an 8-32 \times 1/8" setscrew. Start the setscrew into the dial pointer collar.
- () Slide the dial pointer onto the tuning capacitor shaft. Loosen the tuning capacitor hardware which holds it to the chassis and adjust the capacitor and/or sheet metal to center the dial pointer in the hole. Retighten the hardware.

NOTE: In the following steps, the dial pointer must be positioned so that it will move an equal distance past the dial scale at both ends.

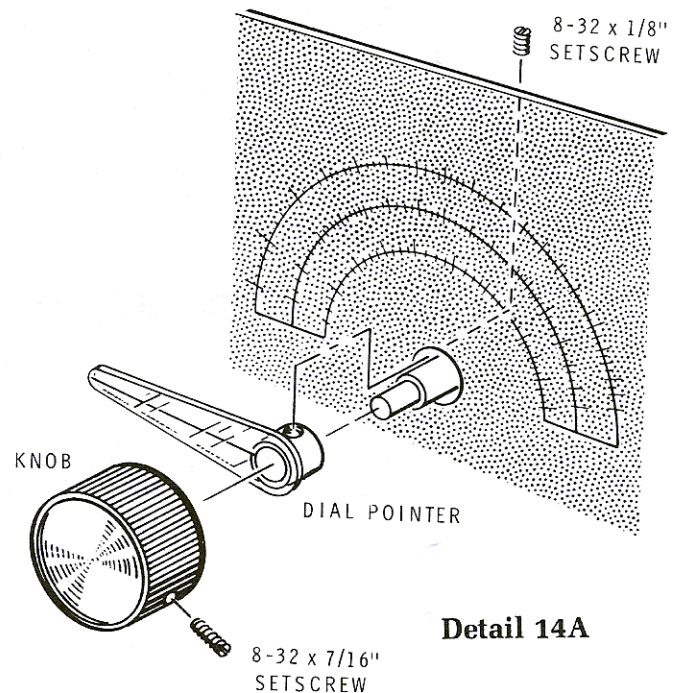

Detail 14A

- () Turn the capacitor fully clockwise and see if the pointer line is the same distance past the dial scale as you set it at the other end. Adjust it as necessary and tighten the setscrew.

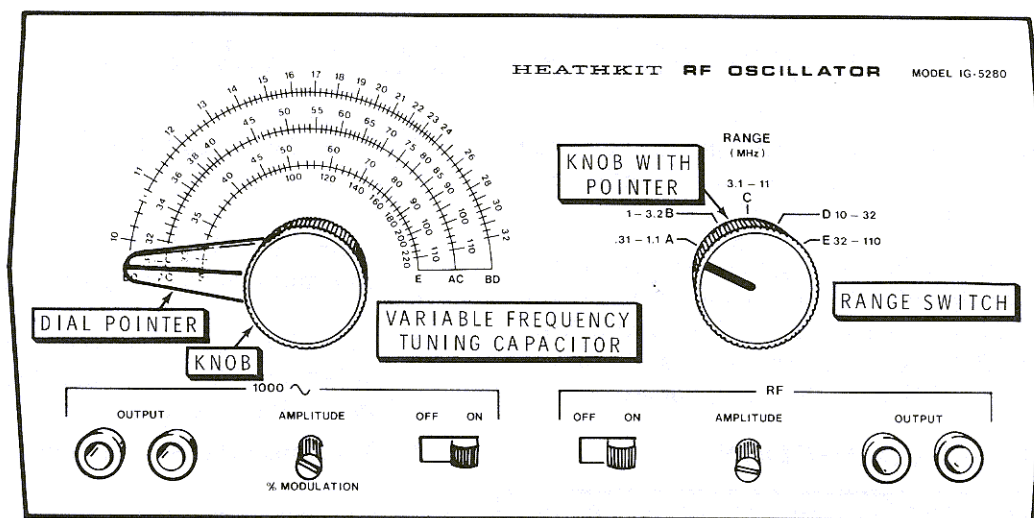

PICTORIAL 14

- () Start 8-32 x 7/16" setscrews into both knobs. Note that one knob has a black pointer; the other knob does not.
- () Slide the knob (without the black pointer) onto the tuning capacitor shaft. Tighten the setscrew.
- () Refer to Detail 14B and use a pair of pliers to turn the Range switch shaft fully counterclockwise.
- () Check the transistors to make sure they are correctly installed.
- () Check the electrolytic capacitors to make sure the plus (+) marked leads are correctly installed.

Proceed to "Adjustments and Calibration."

NOTE: In the next step be sure the pointer aligns properly. If necessary loosen the switch hardware and turn the switch slightly.

- () Slide the remaining knob (with the black pointer) onto the Range switch shaft with the pointer at ".31 - 1.1A." Tighten the setscrew.

This completes the wiring of your RF Oscillator. Carefully perform the following checks.

CHECKOUT

- () Check the foil side of the circuit board for poor solder connections or solder bridges.
- () Cut off any excess lead lengths on the foil side of the circuit board and on the rotary switch, that could touch another foil or connection.

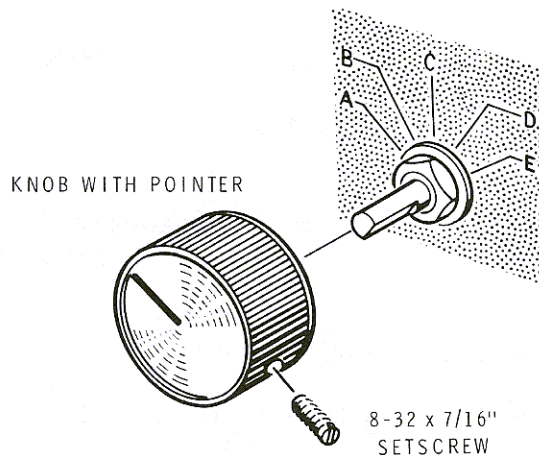

Detail 14B

ADJUSTMENTS AND CALIBRATION

In the following steps, if you do not get the indicated results, turn the Oscillator off and refer to the "In Case of Difficulty" section.

Refer to Pictorial 15 (Illustration Booklet, Page 4) and study the operation of each switch and control of the RF Oscillator. Note the location of the "AMPL ADJ" control (R5), "BIAS ADJ" control (R19), and trimmer capacitors C12 and C22 on the circuit board.

POWER SUPPLY CONNECTION

Perform this step only if you are going to use batteries.

- () Connect the two 9-volt batteries, which you purchased earlier, to the battery connectors. If you wired the power supply switch, place this switch in the Batt position.

NOTE: If you are using battery power ONLY, disregard the following steps and proceed to "Oscillator Amplitude Adjustment."

- () Connect one of the five connector shells coming from the Power Supply to P1 on the mounting plate. Make sure the wire colors at both connectors are the same and are not reversed. See the inset drawing #1.
- () Place the LINE/BATT switch to the LINE position.
- () Plug the Power Supply line cord into the appropriate AC receptacle.

OSCILLATOR AMPLITUDE ADJUSTMENT

- () Place the AF OFF/ON switch in the ON position.
- () Connect a DC voltmeter to the base of Q3 and set the BIAS ADJ control to read 4.3 volts on the meter.
- () Disconnect the DC voltmeter.
- () Place the AF OFF/ON switch in the OFF position.

NOTE: You will need a voltmeter capable of measuring AC for the following steps.

- () Set the meter to the lowest range capable of measuring 2 volts AC.

- () Place the AF OFF/ON switch in the ON position.
- () Turn the AF AMPLITUDE control to the maximum clockwise position.
- () Connect an AC voltmeter to the emitter of Q3 and set the AMP/ADJ control to measure 2 volts rms on the meter.
- () Disconnect the AC voltmeter.

PRESET ADJUSTMENTS

The coil slug adjustment which determines the lower end frequency of each band, has been adjusted to precision standards at the factory.

The trimmer capacitors adjust the high end frequency. When you preset these in the next two steps, the RF Oscillator will be reasonably close to the final calibration.

- () Refer to Pictorial 15 and preset trimmer capacitor C12 as follows: Turn the screw down until it is snug; then turn it counterclockwise 1-1/2 turns.
- () Adjust trimmer C22 to the position shown in Pictorial 15.

NOTE: Two calibration methods are provided for greater accuracy. A frequency counter provides the most accurate and quickest method of calibration. If you have a frequency counter, disregard the "Radio Calibration" steps below and follow the steps under "Frequency Counter Calibration" on Page 26. If you do not have a frequency counter, you may use a radio. Follow the steps under "Radio Calibration."

RADIO CALIBRATION

Bands A through D

- () Turn the RF Oscillator and AM-FM radio on. Allow the Oscillator and radio to warm up for 15 minutes so all components will reach normal operating temperature.
- () Connect the test leads to the RF OUTPUT jacks.

The following procedure will be used to calibrate the RF Oscillator.

First, you will tune in a signal of known frequency on the AM radio. Next, you will set the FREQUENCY dial of the Oscillator to the exact frequency of the station the radio is tuned to. Then you will tune the RF Oscillator to the same frequency as the radio station by adjusting it until you hear a "zero beat" in the radio.

"Zero beat" is the signal that is created by the beating together of the Oscillator signal and the station signal in the radio. Assume that the two signals are 5 to 10 kHz apart. The beat signal will start out as a high pitched tone which gradually changes as the frequency difference becomes lower until the tone becomes very low pitched. Once you pass the zero beat point, the tone will gradually increase in pitch until you can no longer hear it.

At these frequencies, it is often hard to get an exact zero beat (no sound at all) between the signals. Often, a low pitched tone or a slow popping sound will be as close as you can come to a zero beat. The output level of the Oscillator should be just high enough to give a clear beat sound; do not set the output level higher than necessary.

- () Tune the AM radio to a station of known frequency between 800 and 1000 kHz. The frequency of this station should fall directly on one of the calibration points on the frequency dial, such as 800, 850, 900, or 1000 kHz.
- () Turn the FREQUENCY dial on the Oscillator to the exact frequency of the station the radio is tuned to.
- () Turn the RANGE switch to band A.
- () Turn the AF OFF/ON (Modulation) switch to OFF.
- () Turn the RF AMPLITUDE control fully clockwise.
- () Place the red test lead near the loop or antenna lead of the AM radio, but do not connect it directly to the radio.
- () Adjust trimmer capacitor C12 for a zero beat in the radio. Use the RF AMPLITUDE control to set the output level of the Oscillator just high enough to give a clear zero beat in the radio.

This completes the calibration of bands A through D. Turn the AM radio off.

NOTE: You can slightly improve the accuracy if you adjust the slug in each coil by zero beating the Oscillator signal with an accurate frequency standard. For an accurate frequency standard, tune a communications receiver to a WWV frequency such as 2.5 MHz, 5 MHz, 10 MHz, etc., (National Bureau of Standards). You can also obtain standard frequencies from a precision laboratory generator (with an accuracy of at least 1%), used in conjunction with an oscilloscope to indicate the zero beat. If you adjust the coil slugs, adjust each band near the low end of the dial. A coil alignment tool for adjusting the coil slugs is supplied with the kit.

Band E

To calibrate band E to obtain additional accuracy, you must use an FM radio.

- () Turn on the FM radio and tune it to a station between 88 MHz and 100 MHz.
- () Set the RANGE switch to band E, and turn the FREQUENCY dial pointer to the frequency of the FM station.
- () Turn the AF OFF/ON (Modulation) switch to ON, and advance the AMPLITUDE control about 20° clockwise from the maximum counterclockwise position.
- () Connect the test leads to the RF OUTPUT jacks then connect the free ends to the antenna terminals of the FM radio.
- () Turn the Oscillator FREQUENCY dial pointer back and forth and listen for the 1000 Hz tone modulation in the FM radio. This 1000 Hz tone will be weakest at the correct frequency, and it will be louder on both sides of this frequency. Adjust the modulation AMPLITUDE control as required.
- () Turn the Oscillator FREQUENCY dial to the place where the 1000 Hz tone is weakest. If the dial indicator points to a frequency other than the station frequency, adjust trimmer capacitor C22 and retune the dial pointer to the weakest 1000 Hz tone. Repeat this procedure until the correct frequency is indicated on the Oscillator dial.
- () Turn the oscillator and the radio off.

This completes the "Adjustment and Calibration." Proceed to "Final Assembly."



FREQUENCY COUNTER CALIBRATION

- () Move the MODULATION switch to the OFF position.
- () Turn the AMPLITUDE (RF) control fully clockwise.
- () Turn on the RF Oscillator and frequency counter and allow them to warm up for 15 minutes.
- () Connect the RF Oscillator to the frequency counter.

NOTE: Trimmer C12 is used to adjust the high end of bands A through D in the following steps. As you adjust the trimmer for each band, remember that the other bands will also be affected. Adjust the trimmer for the greatest overall accuracy. Use the alignment tool supplied with this kit to adjust the coil slugs.

Adjust each of the bands for the high frequency with the trimmer capacitor and the low frequency of the respective band with the coil slug as follows:

	BAND	FREQUENCY	ADJUST TRIMMER	FREQUENCY	ADJUST COIL
()	A	1.1 MHz	C12	.31 MHz	L1
()	B	3.2 MHz	C12	1 MHz	L2
()	C	11 MHz	C12	3.1 MHz	L3
()	D	32 MHz	C12	10 MHz	L4

NOTE: To adjust coil L5, carefully squeeze the turns together (to lower the frequency) or spread them apart (to raise the frequency).

()	E	90-110 MHz	C22	32-35 MHz	L5
-----	---	------------	-----	-----------	----

- () Turn the oscillator and the frequency counter off.

This completes the "Adjustments and Calibration."
Proceed to "Final Assembly."

FINAL ASSEMBLY

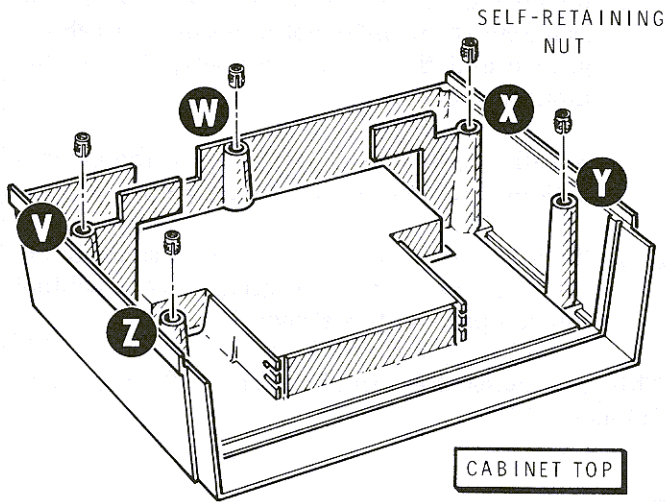

PICTORIAL 16

Refer to Pictorial 16 for the following steps.

- () Position the cabinet top as shown.

- () Install five self-retaining nuts at V, W, X, Y, and Z. Insert the slotted end of the nuts into the cabinet posts and press the nuts into the holes. Use a screwdriver handle to push the nuts down into the holes until they are flush with the posts. Set the cabinet top aside temporarily.

Refer to Pictorial 17 (Illustration Booklet, Page 5) for the following steps.

- () Position the cabinet bottom as shown.
- () Refer to Detail 17A and cut a foam strip in half as shown in the inset drawing.
- () Remove the backing paper from one side of the cut piece and press it into place at BC1 in the cabinet bottom as shown.
- () In the same manner, press the other half of the foam strip in place at BC2.
- () In the same manner, install foam strips in BC3 and BC4.

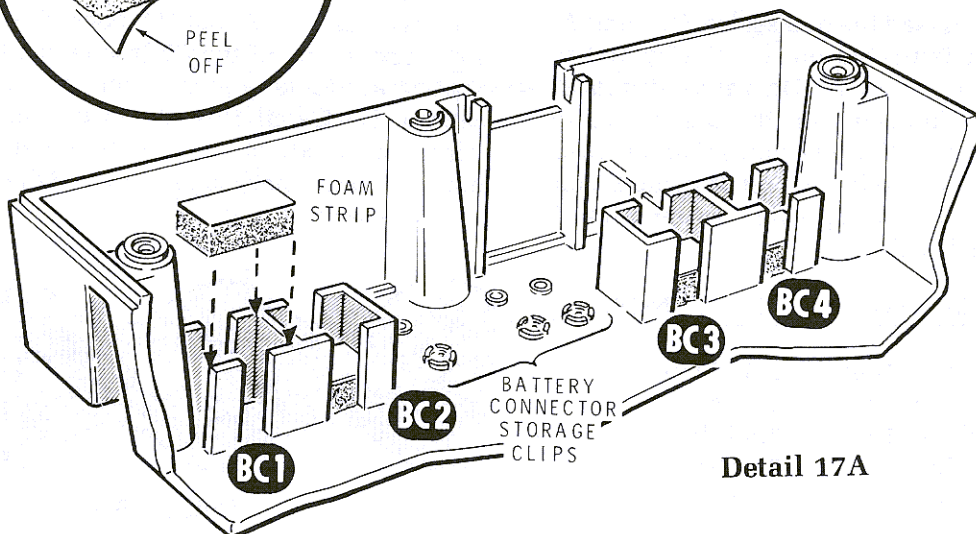
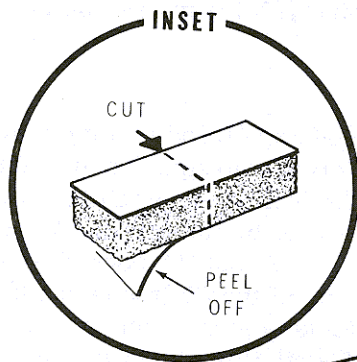

Detail 17A



Refer to Detail 17B for the next four steps.

- () Install the Oscillator in the cabinet bottom. Slide the front panel into the cabinet groove. If you are using batteries with your RF Oscillator, install them in compartments BC3 and BC4 as shown. Note: You may store spare batteries in compartments BC1 and BC2.
- () Secure the chassis with two 6-32 × 3/8" self tapping screws.
- () If you are using the AC Power Supply, snap the 9-volt battery connectors onto the retainers on the cabinet bottom as shown in the Pictorial. This will keep them secure and out of the way.

- () Install the appropriate mounting plate at the rear opening of the cabinet bottom as shown in the inset drawing.
- () Install the cabinet top on the cabinet bottom. Make sure the front panel slides into the cabinet groove and the top fits properly around the mounting plate.
- () Install five 6-32 × 1/2" screws in the cabinet bottom. Tighten the screws securely.
- () Refer to Detail 17C and store any cables or accessories for your RF Oscillator in the cabinet top compartment as shown.

This completes the "Final Assembly." Proceed to "Operation."

OPERATION

Pictorial 15 (Illustration Booklet, Page 4) explains the basic functions of the front panel controls. A detailed explanation of how to read the dial scale, and the use of some front panel controls, is given in the following paragraphs.

DIAL SCALE

The RF output frequency of the Oscillator depends on the number the FREQUENCY dial pointer is set to, and the position of the RANGE switch. Read bands A and C on the center dial scale; bands B and D on the outside dial scale; and band E on the inside dial scale. See inset drawing #2.

Proceed as follows to read the dial scales: On band A, divide the number indicated on the dial by 100 to obtain the frequency in MHz. On bands B and C, divide the number indicated on the dial by 10 to obtain the frequency in MHz. On bands D and E, read the dial directly in MHz. Refer to inset drawing #2 on Pictorial 15 and the following table for examples of how to read the dial scale.

BAND	DIAL READING	FREQUENCY
A	75 (divide by 100)	.750 MHz
B	23 (divide by 10)	2.3 MHz
C	75 (divide by 10)	7.5 MHz
D	23 (read direct)	23 MHz
E	77 (read direct)	77 MHz

NOTE: The numbers from 100 to 220 on the inside of scale E are calibrated harmonic frequencies of band E. This dial scale, which should be read directly, adds another range of frequencies from 100 MHz to 220 MHz. The most commonly used IF frequencies for AM and FM radio receivers are indicated with a special mark on the dial; 455 kHz (AM) is marked on band A and 10.7 MHz (FM) is marked on band D.

GENERAL

When the AF OFF/ON (Modulation) switch is moved to ON, a 1000 Hz audio signal is available at the AF OUTPUT jacks. With this switch ON, you can modulate the RF signal by turning the AF AMPLITUDE control clockwise. About 20° clockwise rotation gives 30% modulation of the RF frequency. If an oscilloscope is available, you may observe the modulated pattern. See Detail 15A. When maximum = 2X the minimum, modulation = 33%. When you use the audio output alone, you may turn off the RF Oscillator to save battery power.

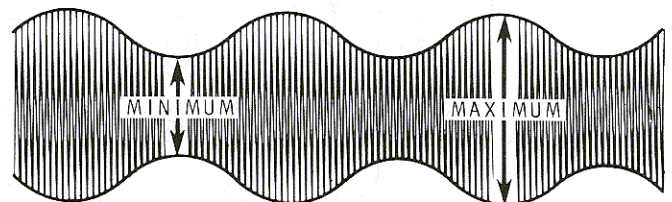

Detail 15A

APPLICATIONS

You can use your RF Oscillator as an RF signal source for the peak alignment of tuned circuits in some FM radios and tuners. More often, though, the sweep alignment method is used to align FM radios and tuners. For sweep alignment, an RF sweep generator is needed and your Oscillator may be used as a marker generator. Whenever possible, it is best to follow the detailed instructions from the manufacturer of the FM radio or tuner.

There are many other applications for this Oscillator. Two basic applications are outlined here under AM Radio Alignment and Signal Injection.

AM RADIO ALIGNMENT

Pictorial 18 (Illustration Booklet, Page 6) shows a block diagram of a typical AM radio. This diagram includes all of the circuits that must be aligned. The radio speaker or a suitable voltmeter may be used as the output indicator. A voltmeter will indicate smaller changes in the output signal.

If you use a DC voltmeter, set it to measure negative DC volts, and connect it to the output of the AVC filter circuit as shown. If you use an AC voltmeter, connect it between the two outside lugs of the volume control or across the speaker terminals.

Be sure to use the proper frequency for alignment of the IF transformers. An IF frequency of 455 kHz will be used in the following procedure, since it is used in most AM radios, but your radio may use another IF frequency such as 262 kHz or 460 kHz. Follow the detailed instructions from the manufacturer of the radio whenever possible.

1. Turn on the radio, RF Oscillator, and voltmeter if one is used. Allow the equipment to warm up for 15 minutes so that all components will reach normal operating temperature.
2. Turn the AM radio dial to the high frequency end of the dial.
3. If the radio uses a loop or rod antenna, place the red lead near the antenna. If there is no loop or rod antenna, connect the red lead to the antenna terminal and the black lead to the chassis of the radio.
4. Set the Oscillator to 455 kHz (Band A) and turn on the 1000 Hz modulation oscillator. Turn the AF AMPLITUDE control clockwise approximately 10°.
5. Use an insulated alignment tool to adjust the IF transformers which are shown in the shaded portions of Pictorial 18. Start with the last IF transformer (next to the detector stage) and work toward the first; adjust each one for a maximum reading on the voltmeter or the loudest signal from the speaker. At the same time, reduce the Oscillator output to keep the output at minimum but still large enough to give an indication on the voltmeter.
6. Since the IF adjustments affect each other, repeat the adjustments at least once for best results.
7. Set the RF Oscillator and radio to 1600 kHz. Adjust the oscillator trimmer capacitor (shown by light arrow in Pictorial 18) for maximum voltage reading.

8. Set the RF Oscillator and radio to 1400 kHz. Adjust the antenna trimmer capacitor (also shown by light arrow) for maximum voltage reading.
9. Set the RF Oscillator to 600 kHz and tune the AM radio to 600 kHz.
10. Adjust the slug of the oscillator coil (shown by the dark arrow) for maximum reading on the voltmeter. Now tune the radio a slight amount in either direction so the signal sounds faint or the voltage reading decreases slightly. Again adjust the oscillator coil for maximum voltage, then note whether the voltage is larger or smaller than it was before. Retune the radio a slight amount again (in the same direction if the voltage increased, and in the other direction if the voltage decreased) and adjust the oscillator coil for maximum voltage. Repeat this retuning and coil adjustment process until you locate the oscillator coil adjustment that produces the largest reading on the voltmeter.
11. Repeat steps 8 through 10 again because there will be some interaction between the adjustments.

This completes the alignment of the AM radio.

SIGNAL INJECTION

Signal injection is a technique used to troubleshoot weak or dead electronic devices (radio and TV receivers, hi-fi amplifiers, etc.) to find the circuit that is not operating properly. In this method, a signal is coupled into the stages of the defective equipment, one stage at a time, until the defective stage is located.

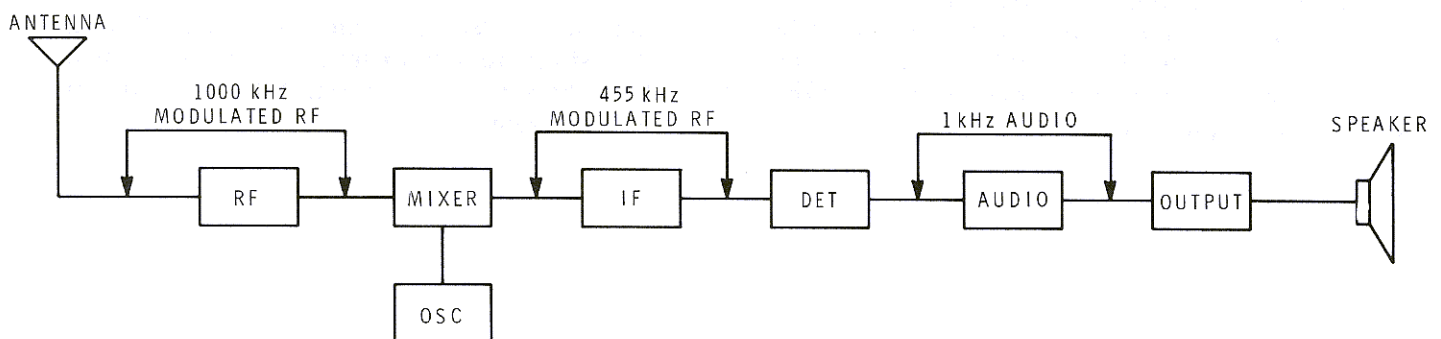

PICTORIAL 20

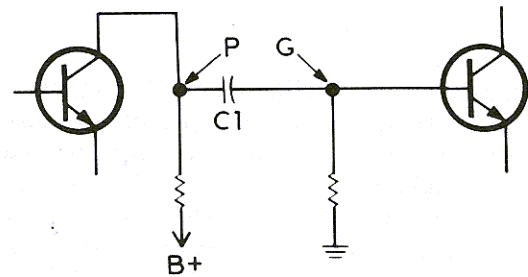

PICTORIAL 19

Use care so the test signal does not overdrive the stage it is connected to.

For example, this method might be used to find an open coupling capacitor between two amplifier stages. In this case, the signal would be heard when the 1000 Hz audio signal from the Oscillator is connected to the base of the second transistor. This is shown as point G in Pictorial 19. The signal will not be heard when the Oscillator is connected to the collector of the first transistor (point P).

Pictorial 20 shows how signal injection can be used to find the faulty stage of an AM radio receiver. First the 1000 Hz audio signal from the Oscillator is connected to the base of the output transistor then moved back to the audio transistor. If a normal sound is heard from the speaker in both cases, a modulated RF signal would be used to check the remaining stages of the radio. The modulated RF frequencies shown in Pictorial 20 would be used.

IN CASE OF DIFFICULTY

This part of the Manual provides you with information that will help you locate and correct difficulties which may occur in your Oscillator. This information is divided into two sections. The first section, "General," contains suggestions of a general nature in the following areas:

- Visual check and inspection.
- Precautions to observe when bench testing.

The second section is a "Troubleshooting Chart" which contains a series of "Conditions" and "Possible Causes." Start your troubleshooting procedure by first reading the following "General" section. Then proceed to the appropriate "Condition" and "Possible Cause."

GENERAL

Visual Checks

1. About 90% of the kits that are returned for repair do not function properly due to poor soldering. Therefore, you can eliminate many troubles by a careful inspection of connections to make sure they are soldered as described in the "Soldering" section of the "Assembly Notes." Reheat any doubtful connections and be sure all the wires are soldered at places where several wires are connected. Check carefully for solder bridges between circuit board foils.
2. Check to be sure that the transistors are in their proper locations, and are installed correctly.
3. Check the value of each part. Be sure the proper part has been wired into the circuit, as shown in the Pictorial diagrams and as called out in the wiring instructions.

Check each electrolytic capacitor to be sure the lead near the positive (+) marking is at the correct position.

4. Recheck the wiring. Trace each lead in colored pencil on the Pictorial as you check it. It is frequently helpful to have a friend check your

work. Someone who is not familiar with the unit may notice something you have consistently overlooked.

5. Check all component leads connected to the circuit boards. Make sure the leads do not extend too far through the circuit board and make contact with other connections or parts.
6. Check all of the wires that are connected to the circuit board to be sure the wires do not touch the chassis. Make sure all wires are properly soldered.

Precautions for Bench Testing

- Be cautious when you test transistors. Although they have almost unlimited life when used properly, they are much more vulnerable to damage from excessive voltage and current than other circuit components.
- Be careful so you do not short any terminals to ground when you make voltage measurements. If the probe should slip, for example, and short out a bias or voltage supply point, it may damage one or more components.

Do not remove any components from the circuit board while the unit is turned on.

When you make repairs, make sure you eliminate the cause as well as the effect of the trouble. If, for example, you find a damaged resistor, make sure you find out what (wiring error, etc.) caused the resistor to become damaged. If the cause is not eliminated, the replacement resistor may become damaged when the unit is put back into operation.

Refer to the "X-Ray Views" (Page 35), "Identification Charts" (Page 36), and "Schematic Diagram" (Illustration Booklet, Page 7) to locate the various components.

Troubleshooting Chart

The following chart lists conditions and possible causes of specific malfunctions. If a particular part is mentioned (Q1 for example) as a possible cause, check that part and other components connected to that part to see that they are installed and/or wired correctly. Also check for solder bridges and poor connections in the surrounding area. It is also possible, on rare occasions, for a part to be faulty and require replacement.

PROBLEM	POSSIBLE CAUSE
No audio output.	Q1, Q2, Q3, or R5 adjustment.
No RF output.	Q4, Q5, Q6, Q7
No Vcc to RF section. (+9A)	Q4.
RF output distorted.	Q7.
Modulation pattern distorted.	Q7, Q4.

In an extreme case where you are unable to resolve a difficulty, refer to the "Customer Service" information inside the rear cover of the Manual. Your Warranty is located inside the front cover.

SPECIFICATIONS

RF OUTPUT SIGNAL

Frequency Range	310 kHz to 110 MHz in five bands (bands A through E). 100 MHz to 220 MHz (additional band of calibrated harmonics).
Output Voltage	100 mV rms (open circuit) approximately.
Internal Modulation	1000 Hz.

AF OUTPUT SIGNAL

Frequency	1000 Hz.
Output Voltage	2.0 volts rms (open circuit).

GENERAL

Front Panel Controls	Variable Frequency control. Range (Band) switch. Attenuator control (RF Amplitude). Modulation or AF Output control (AF Amplitude). Power on/off switches.
Power Supply	Two 9-volt batteries and/or Heathkit Model IPA-5280-1.
Cabinet Dimensions	11" wide × 5 3/4" high × 7 3/4" deep. (27.9 cm wide × 14.6 cm high × 19.7 cm deep).
Net Weight	3 1/4 lbs. (1.5 kg).

The Heath Company reserves the right to discontinue products and to change specifications at any time without incurring any obligation to incorporate new features in products previously sold.

CIRCUIT DESCRIPTION

Refer to the Schematic drawing (Illustration Booklet, Page 7).

A Hartley oscillator consisting of transistor Q5 and its associated circuitry, including coils L1 through L4, produces 310 kHz to 32.0 MHz in four bands. The higher band, 32 MHz to 110 MHz, has a separate oscillator that consists of Q6 and its associated circuitry, including coil L5. The separate high band oscillator is necessary since it is impractical to switch coils in this frequency range.

The output from either oscillator is coupled to output FET Q7. The high frequency signal from Q6 couples through capacitor C18 to the gate of Q7. The signals from Q5 are capacitively coupled between the circuit board foils to the gate of Q7.

The Q7 output signal couples through amplitude control R16 and C11 to the front panel output jack.

RF output modulation is provided by varying the amount of voltage applied to the oscillator circuit. Q4 is connected as an emitter follower and acts as a "regulator" to provide the oscillators with the DC voltage necessary for the desired RF output. A modulating signal applied to the base of Q4 varies the RF

output in accordance with this signal and provides the amplitude modulated RF output. Amplitude Modulation control, R9, adjusts the audio output level and/or the modulation depth of the RF output. A voltage divider, resistors R10 through R14, switched by the Range switch and connected to the base of Q4, provides approximately the same RF output on all ranges.

The audio oscillator circuit (Q1, Q2, and Q3, and the associated components) is a form of Wein bridge oscillator. Q1 and Q2 provide the required amplification, and Q3 acts as an output and buffer stage. The amplitude of the output voltage is controlled by the amount of feedback applied as adjusted by control R5. Usually about 2 volts RMS is adequate to modulate the RF circuit; higher output might lead to severe waveform distortion.

Power is supplied by two 9-volt batteries, one for the RF and one for the AF. The Oscillator can be powered by the Heathkit Model IPA-5280-1 AC Power Supply. In this case, the two supplies are separated by the 2.9 mH coil, L6 (#45-81) to minimize the amount of RF leaving the Oscillator cabinet on the power supply cord.

CIRCUIT BOARD X-RAY VIEW

NOTE: To find the PART NUMBER of a component for the purpose of ordering a replacement part:

- A. Find the circuit component number (R5, C3, etc.) on the X-Ray View.
- B. Locate this same number in the "Circuit Component Number" column of the "Parts List" in the front of this Manual.
- C. Adjacent to the circuit component number, you will find the PART NUMBER and DESCRIPTION which must be supplied when you order a replacement part.

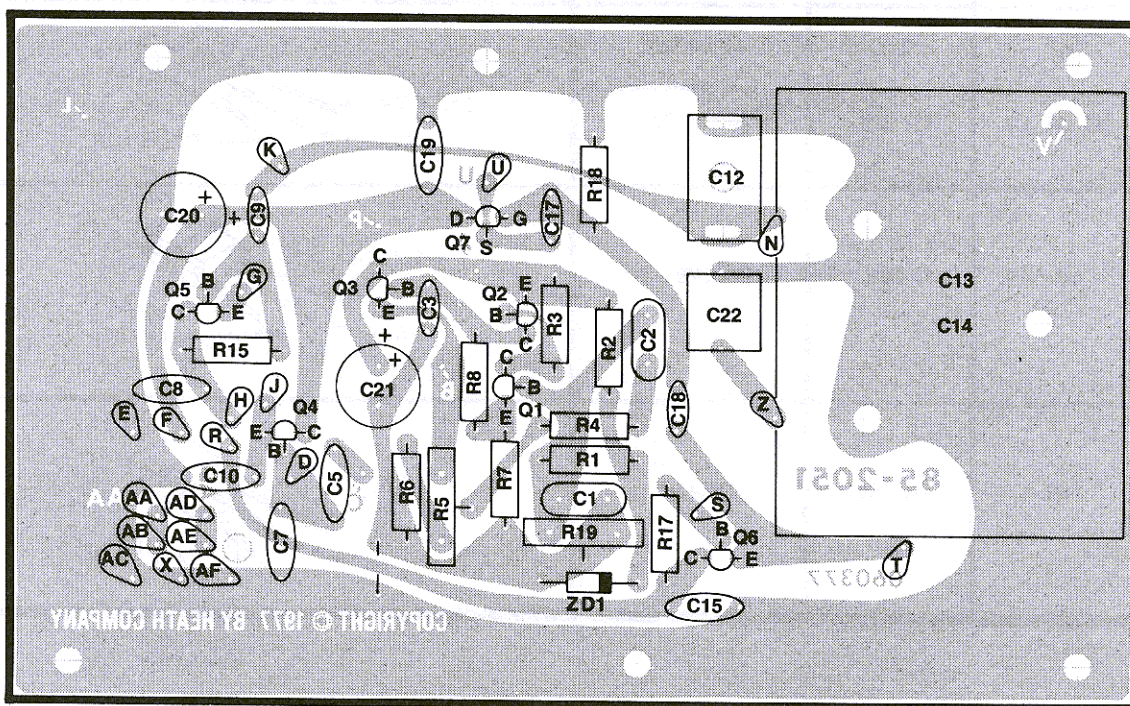

VIEWED FROM COMPONENT SIDE

SEMICONDUCTOR IDENTIFICATION CHART

SCHEMATIC NUMBER	HEATH PART NUMBER	MANUFACTURER'S NUMBER	LEAD IDENTIFICATION
Q2	417-235	2N4121	
Q1,	417-134	MPS6520	
Q3, Q4, Q5	417-801	MPSA 20	
Q6	417-293	2N5770	
Q7	417-291	2N5458	

FOR PARTS REQUESTS ONLY

- Be sure to follow instructions carefully.
- Use a separate letter for all correspondence.
- Please allow 10 - 14 days for mail delivery time.

DO NOT WRITE IN THIS SPACE

INSTRUCTIONS

- Please print all information requested.
- Be sure you list the correct **HEATH** part number exactly as it appears in the parts list.
- If you wish to prepay your order, mail this card and your payment in an envelope. Be sure to include 10% (\$1.00 minimum, \$5.00 maximum) for insurance, shipping and handling. Michigan residents add 4% tax.
Total enclosed \$ _____
- If you prefer COD shipment, check the COD box and mail this card. COD

NAME _____
 ADDRESS _____
 CITY _____
 STATE _____ ZIP _____

The information requested in the next two lines is not required when purchasing nonwarranty replacement parts, but it can help us provide you with better products in the future.

Model # _____ Invoice # _____
 Date _____ Location _____
 Purchased _____ Purchased _____

LIST HEATH PART NUMBER	QTY.	PRICE EACH	TOTAL PRICE

TOTAL FOR PARTS	
HANDLING AND SHIPPING	
MICHIGAN RESIDENTS ADD 4% TAX	
TOTAL AMOUNT OF ORDER	

SEND TO: **HEATH COMPANY**
 BENTON HARBOR
 MICHIGAN 49022
ATTN: PARTS REPLACEMENT

Phone (Replacement parts only): 616 982-3571

THIS FORM IS FOR U.S. CUSTOMERS ONLY
 OVERSEAS CUSTOMERS SEE YOUR DISTRIBUTOR

FOR PARTS REQUESTS ONLY

- Be sure to follow instructions carefully.
- Use a separate letter for all correspondence.
- Please allow 10 - 14 days for mail delivery time.

DO NOT WRITE IN THIS SPACE

INSTRUCTIONS

- Please print all information requested.
- Be sure you list the correct **HEATH** part number exactly as it appears in the parts list.
- If you wish to prepay your order, mail this card and your payment in an envelope. Be sure to include 10% (\$1.00 minimum, \$5.00 maximum) for insurance, shipping and handling. Michigan residents add 4% tax.
Total enclosed \$ _____
- If you prefer COD shipment, check the COD box and mail this card. COD

NAME _____
 ADDRESS _____
 CITY _____
 STATE _____ ZIP _____

The information requested in the next two lines is not required when purchasing nonwarranty replacement parts, but it can help us provide you with better products in the future.

Model # _____ Invoice # _____
 Date _____ Location _____
 Purchased _____ Purchased _____

LIST HEATH PART NUMBER	QTY.	PRICE EACH	TOTAL PRICE

TOTAL FOR PARTS	
HANDLING AND SHIPPING	
MICHIGAN RESIDENTS ADD 4% TAX	
TOTAL AMOUNT OF ORDER	

SEND TO: **HEATH COMPANY**
 BENTON HARBOR
 MICHIGAN 49022
ATTN: PARTS REPLACEMENT

Phone (Replacement parts only): 616 982-3571

THIS FORM IS FOR U.S. CUSTOMERS ONLY
 OVERSEAS CUSTOMERS SEE YOUR DISTRIBUTOR

CUT ALONG DOTTED LINE

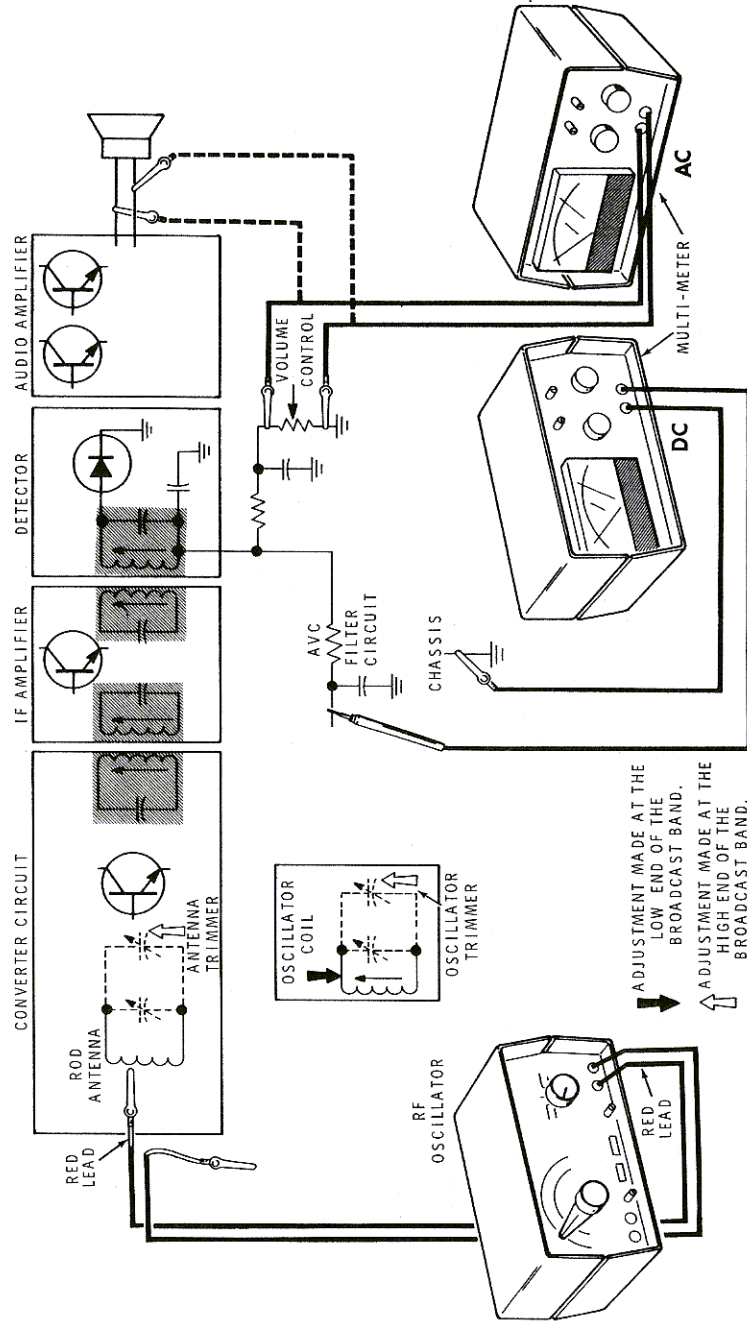

PICTORIAL 18

ILLUSTRATION BOOKLET

Part of 595-1957-04

PARTS PICTORIAL

H1

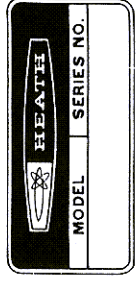
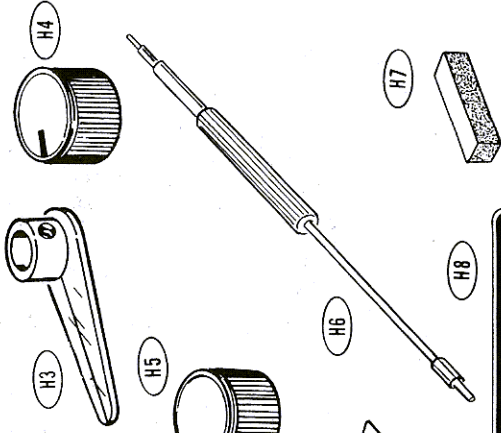
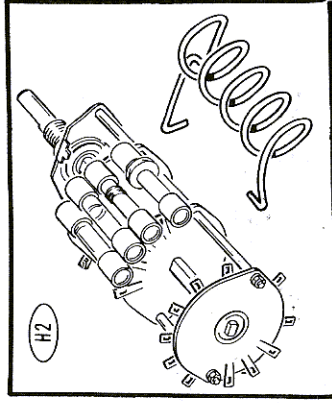
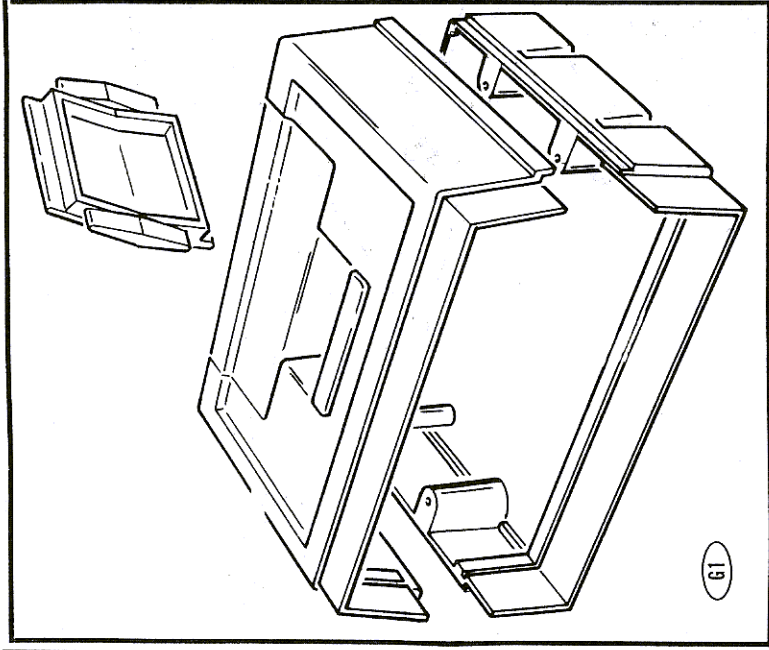
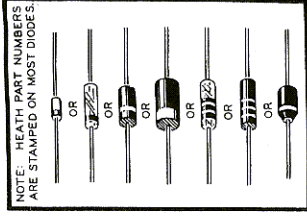

Copyright © 1977
Heath Company
All Rights Reserved
Model IC-5280 Printed in the United States of America

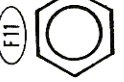
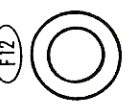
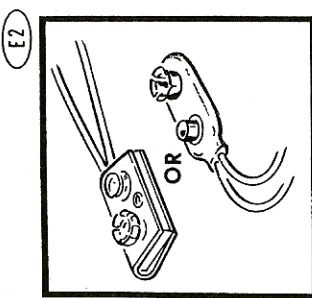
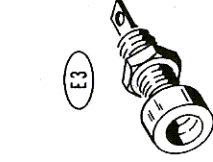
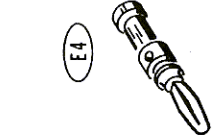
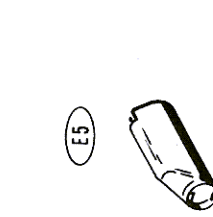
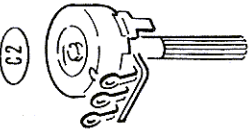
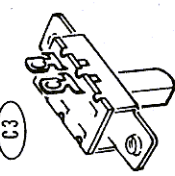
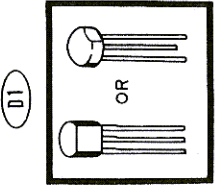
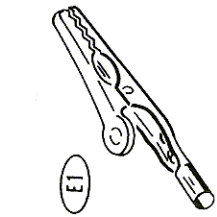
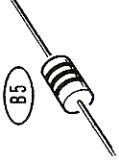
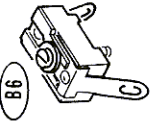
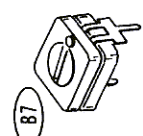
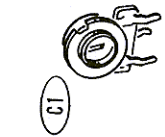
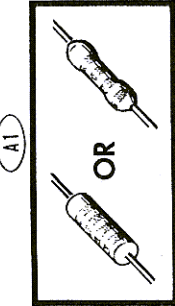
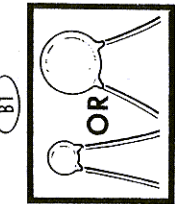
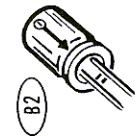
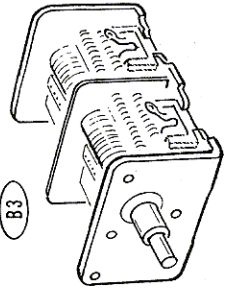

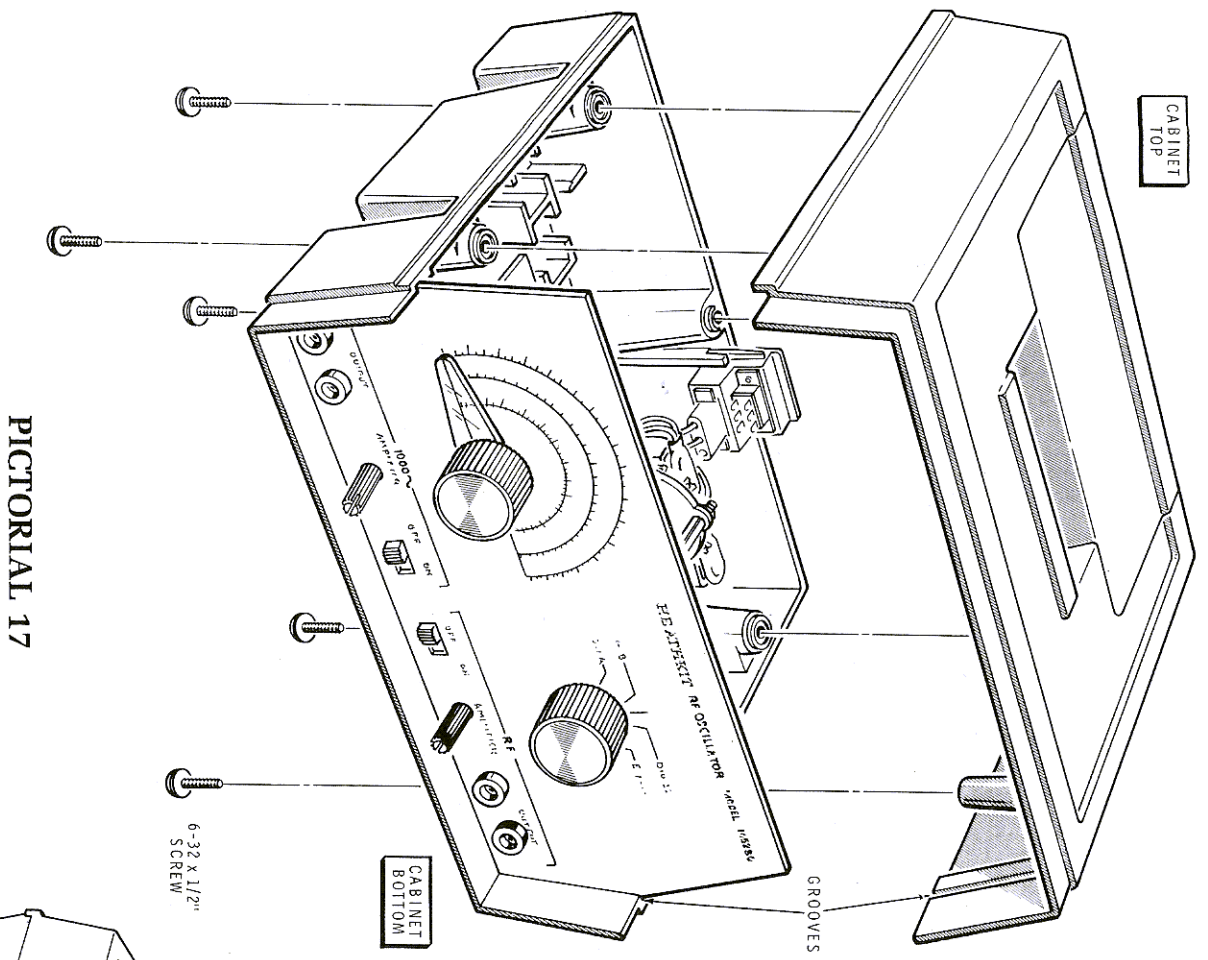

PICTORIAL 17

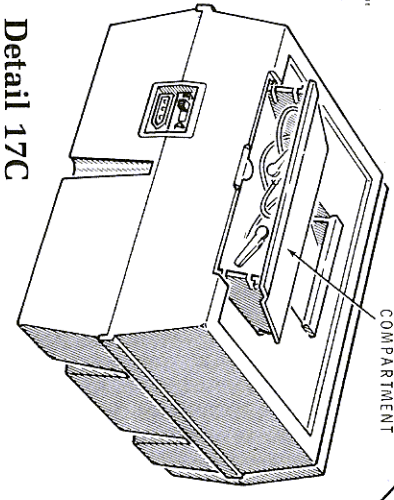

Detail 17C

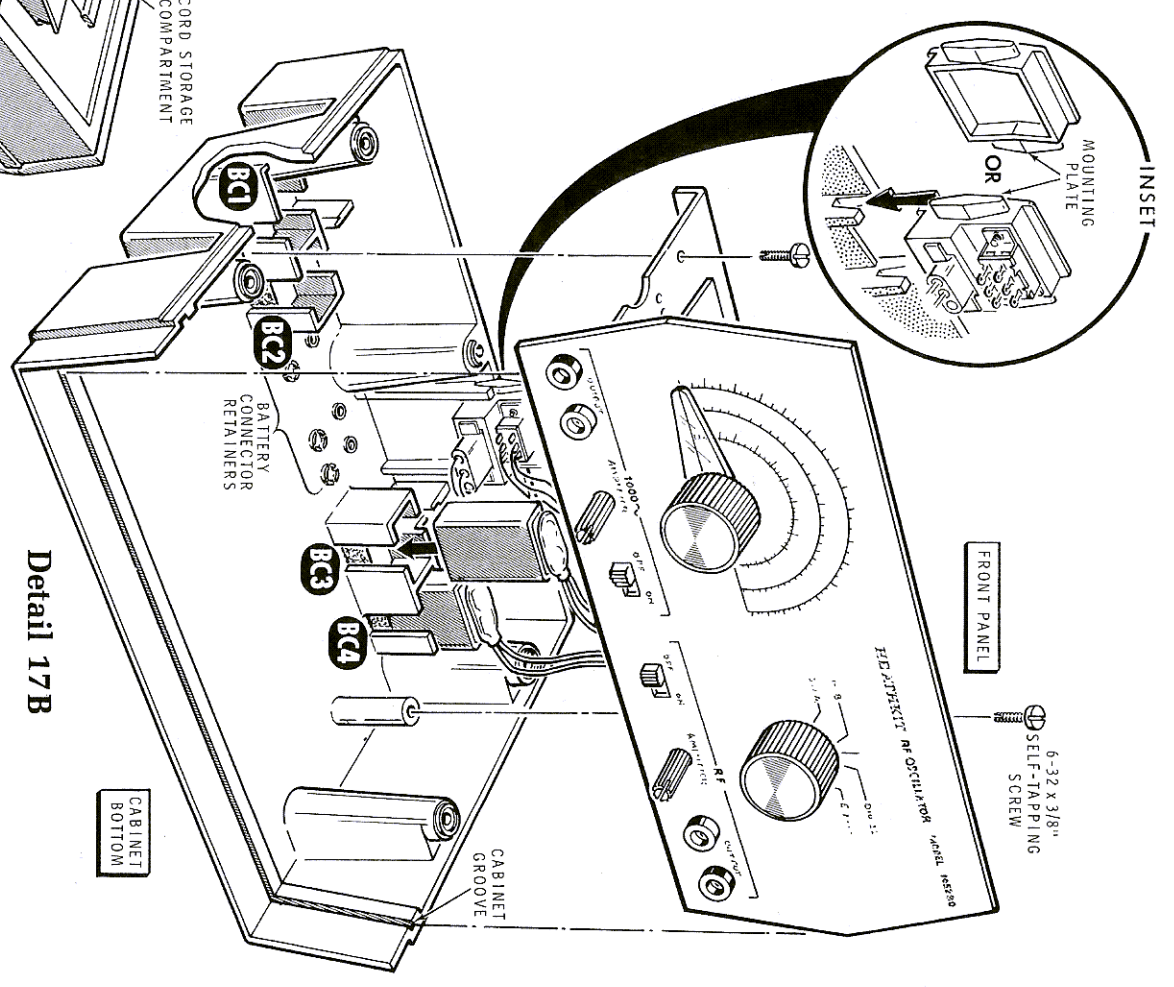

Detail 17B

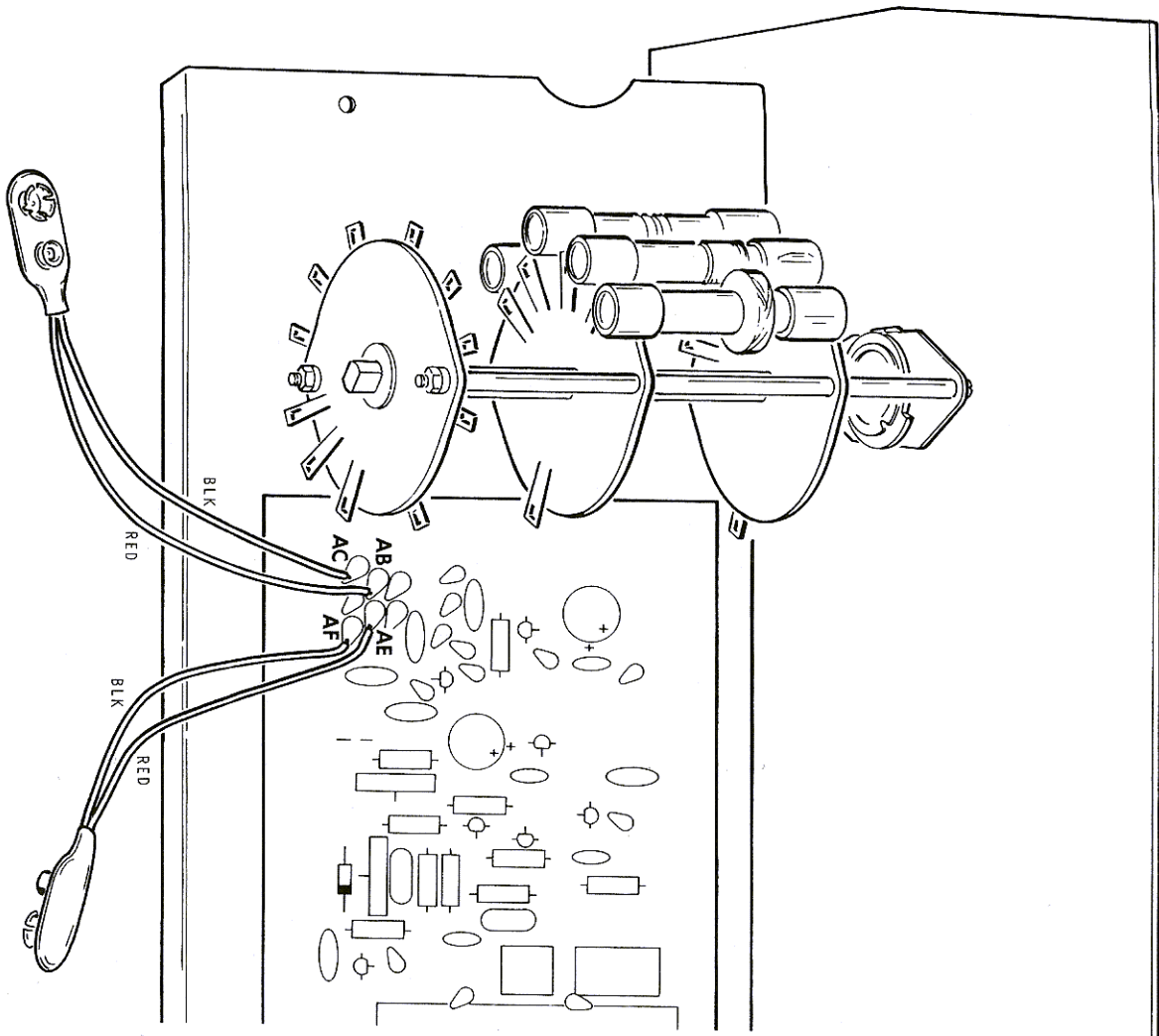

Detail 10B

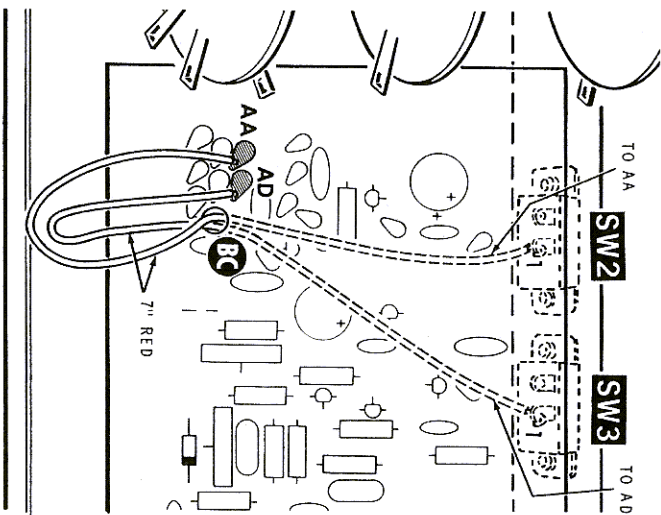

Detail 10C

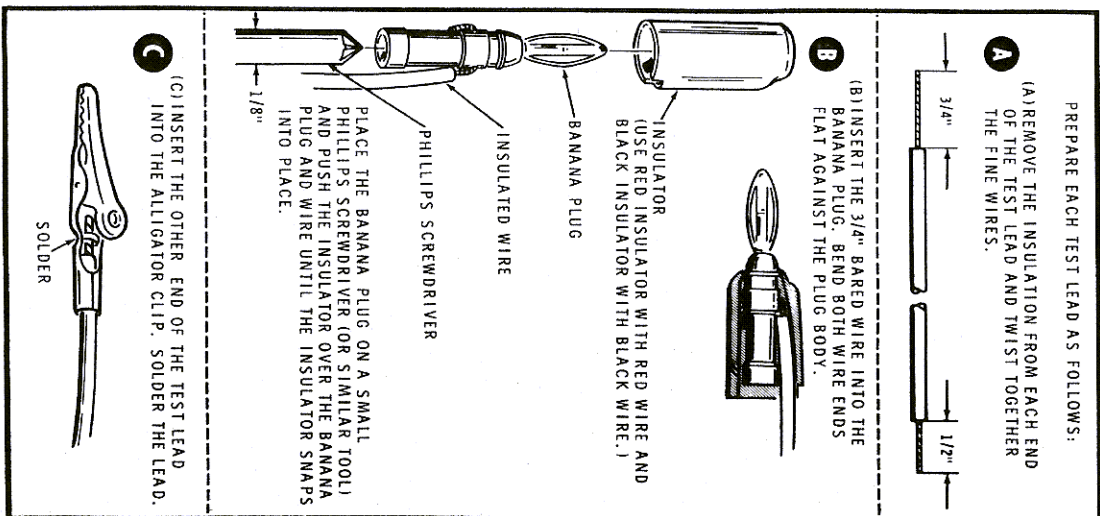

PICTORIAL 11

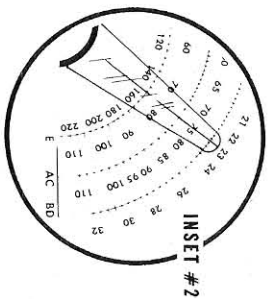

A

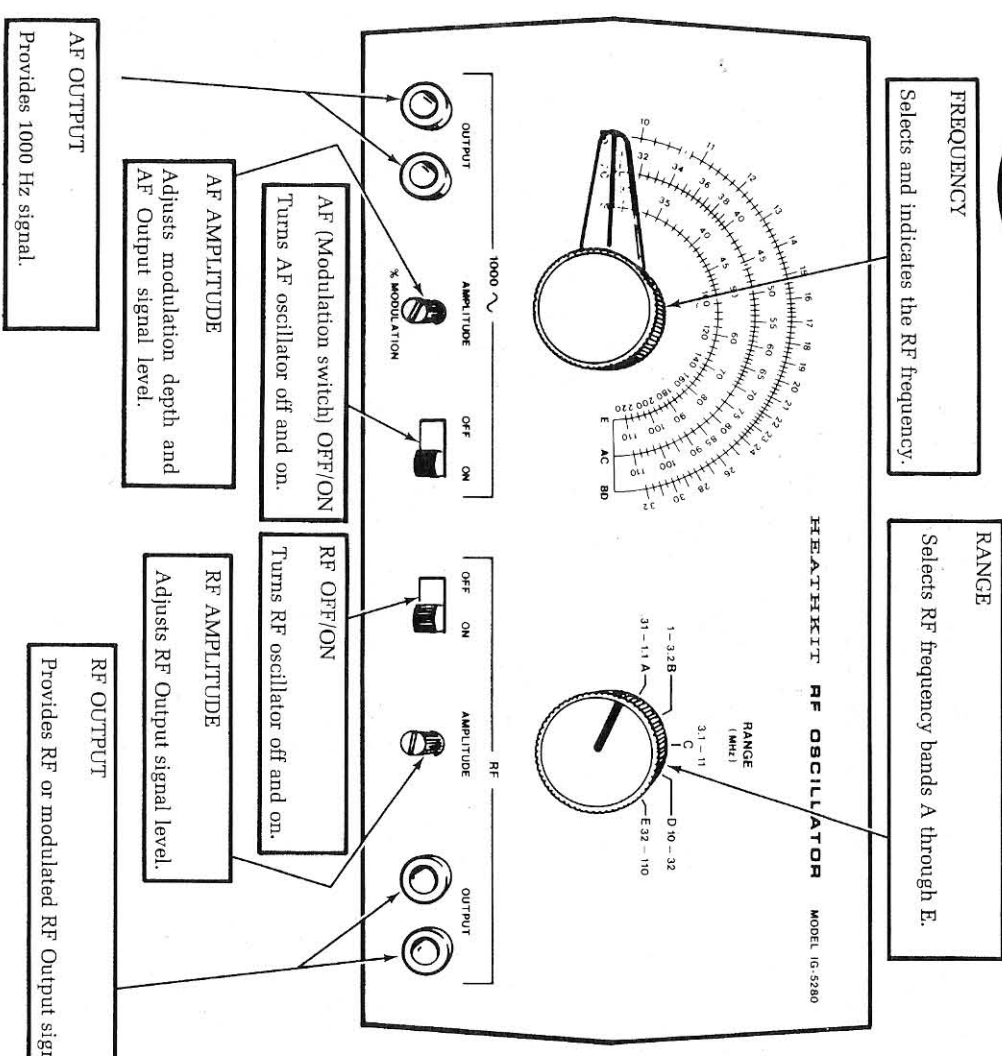

B

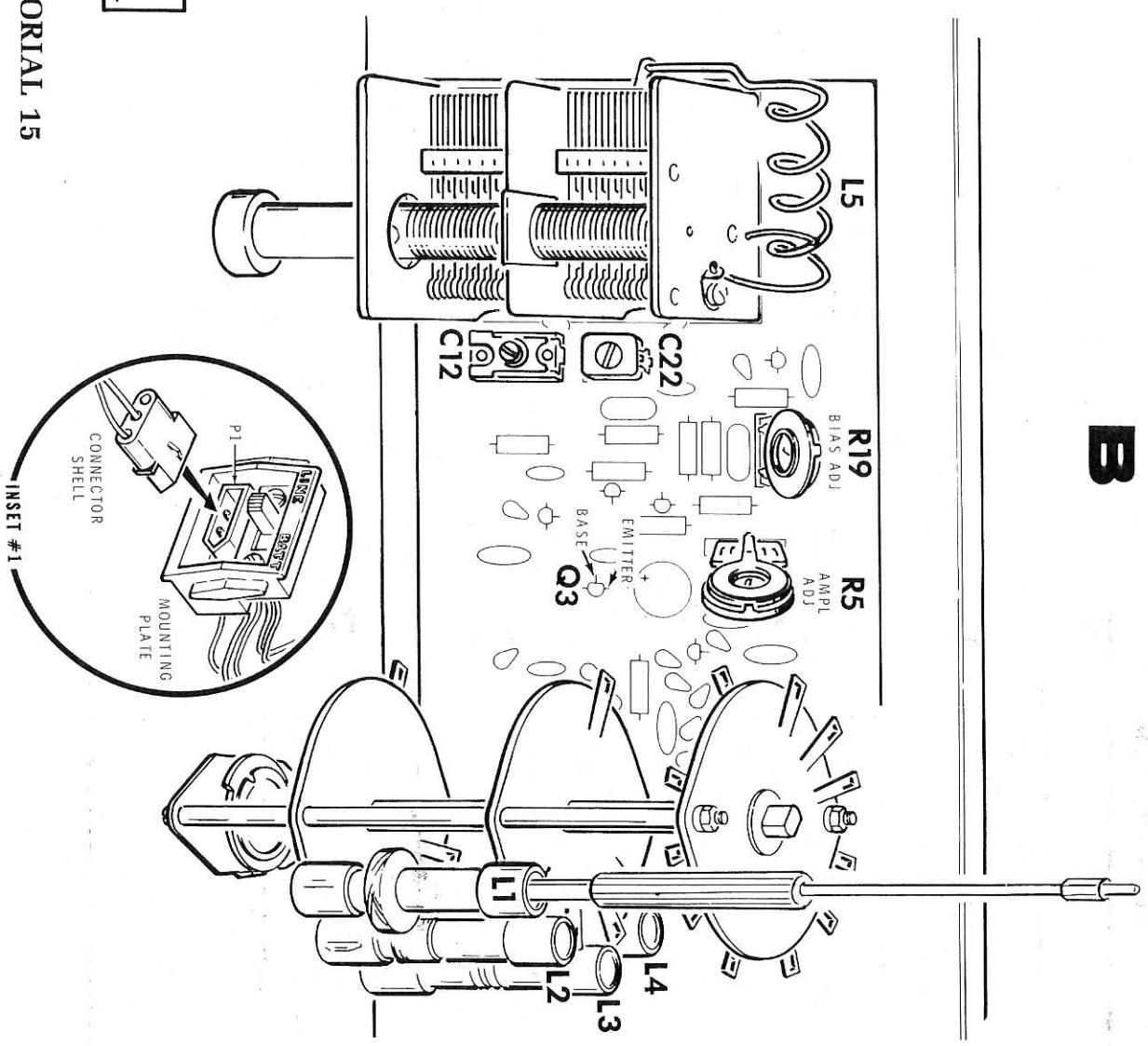

PICTORIAL 15

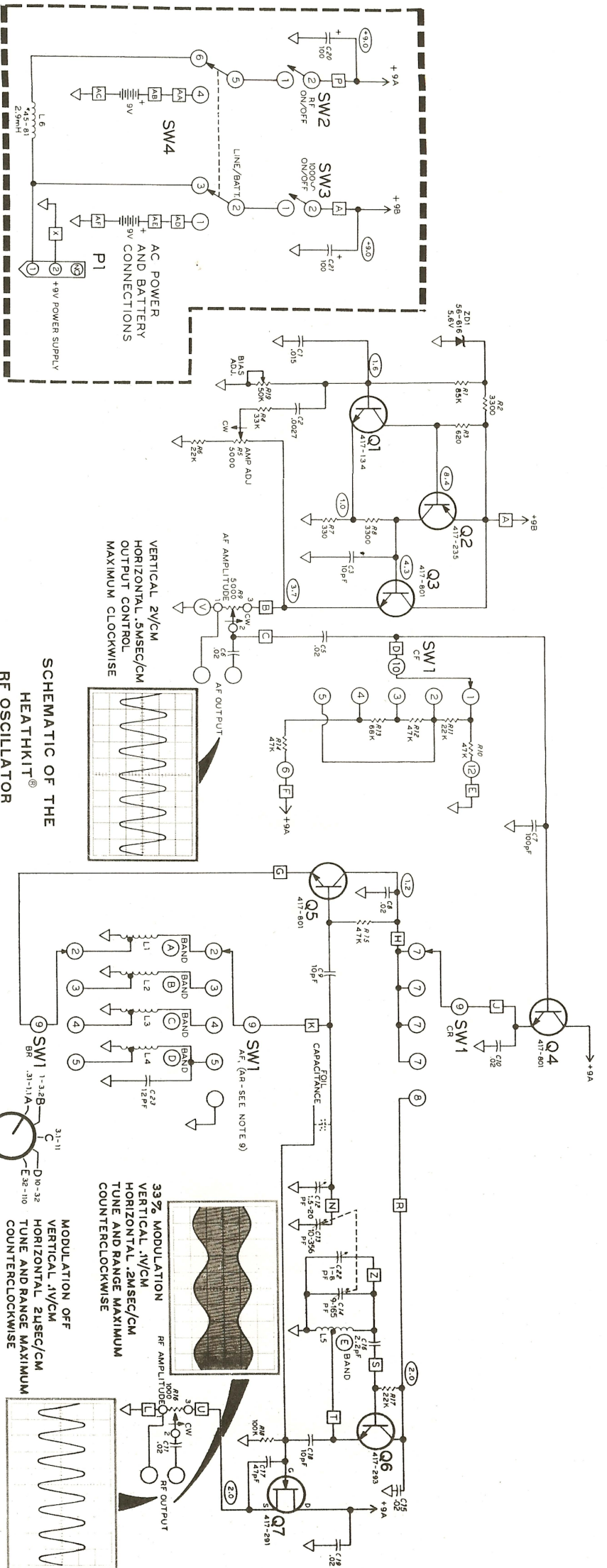

SCHEMATIC OF THE
HEATHKIT®
RF OSCILLATOR
MODEL IG-5280

- NOTES:
1. RESISTORS ARE 1/2 WATT, 5%, UNLESS OTHERWISE NOTED.
 2. RESISTOR VALUES ARE IN OHMS (K=1,000, M=1,000,000).
 3. CAPACITOR VALUES ARE IN μ F, UNLESS OTHERWISE NOTED.
 4. ∇ DENOTES CIRCUIT GROUND.
 5. \circ DENOTES A DC VOLTAGE MEASURED FROM THE POINT INDICATED TO GROUND WITH THE FOLLOWING CONDITIONS:
 - A. RANGE SWITCH (SW1) MAXIMUM COUNTERCLOCKWISE.
 - B. TUNING CAPACITOR (C12, C13) MAXIMUM COUNTERCLOCKWISE.
 - C. AF AMPLITUDE MAXIMUM COUNTERCLOCKWISE.
 - D. MEASUREMENTS MADE WITH A HIGH IMPEDANCE VOLTMETER.
 6. \square DENOTES A CIRCUIT BOARD CONNECTION.
 7. \circ DENOTES OTHER CONNECTIONS.
 8. SWITCHES ARE SHOWN IN CW POSITION. "D" ON SWITCHES DENOTES DUMMY LUGS USED FOR ELECTRICAL TIE POINTS.
 9. SW1AR SHORTS ALL UNUSED COILS TO GROUND.

