

Assembly
and
Operation
of the

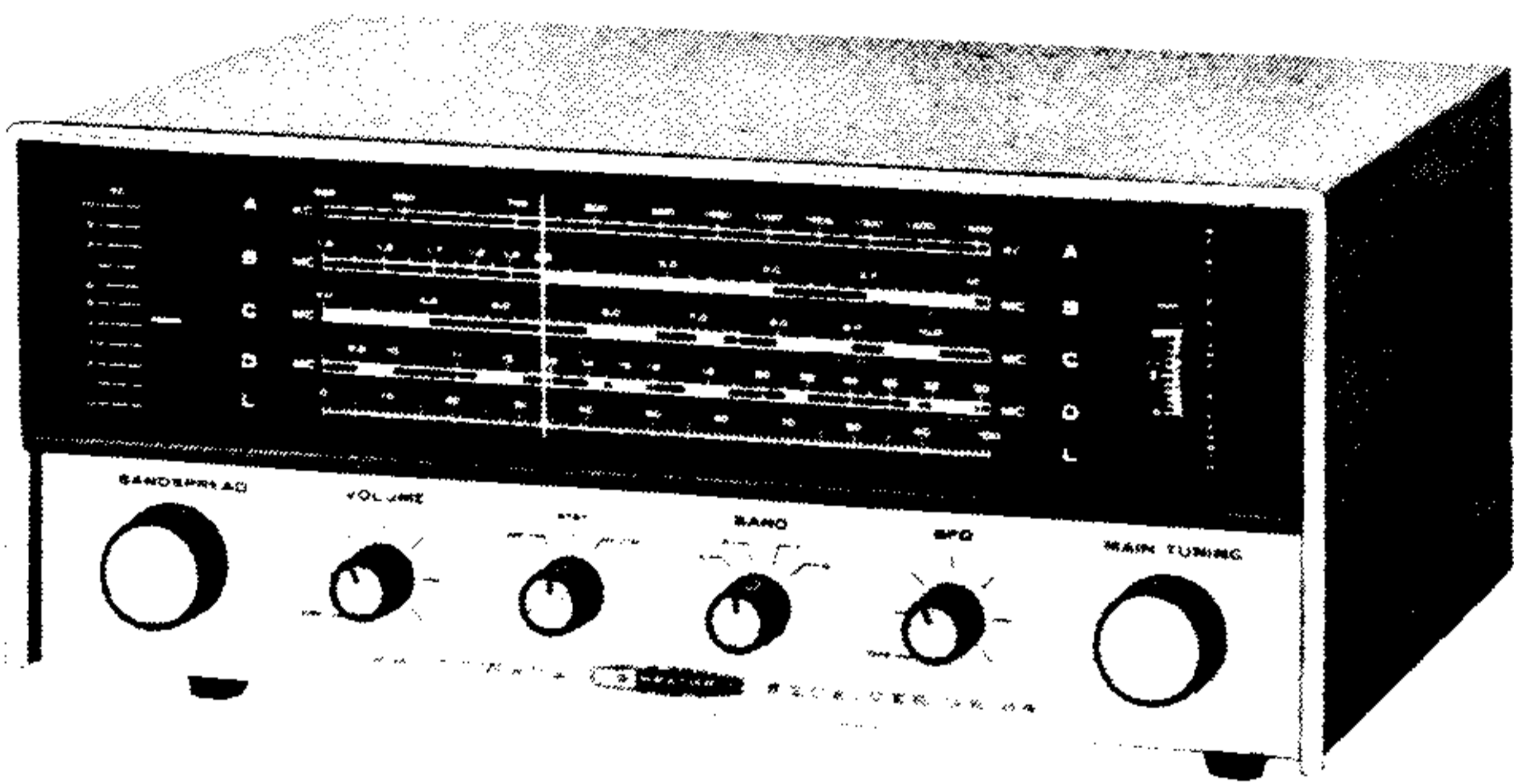

SHORTWAVE
RECEIVER
MODEL GR-64



HEATH COMPANY
BENTON HARBOR,
MICHIGAN

TABLE OF CONTENTS

Specifications.	2
Introduction.	3
Introduction To Radio.	3
Circuit Description.	4
Construction Notes.	5
Parts List.	6
Proper Soldering Techniques.	8
Circuit Board Wiring And soldering.	9
Step-By-Step Procedure	11
Step-By-Step Assembly	
Circuit Board Wiring.	11
Chassis Parts Mounting.	15
Wiring.	20
Final Chassis Bottom Wiring.	26
Dial Cord Stringing.	28
Chassis Top Wiring.	30
Bottom Plate Preparation.	32
Resistance Measurements And Initial Test.	33
Alignment.	35
Alignment Chart.	36
Cabinet Installation.	38
Operation.	38
Antenna Installation.	39
In Case Of Difficulty.	40
Service Information	
Service.	42
Replacements.	43
Shipping Instructions.	43
Schematic. . . (fold-out from page).	43
Warranty.	44

INTRODUCTION

The Heathkit Model GR-64 Shortwave Receiver is designed to provide shortwave and standard broadcast band reception. The Receiver tunes from 550 kc to 30 mc in four overlapping bands. Amateur, foreign, marine, and broadcast frequencies are indicated on the dial.

The Receiver features a relative signal strength meter, electrical bandspread for all four bands, a BFO control, an automatic noise limiter cir-

cuit and a headphone jack. A large printed circuit board is used for circuit stability and ease of assembly. The transformer-operated power supply uses two silicon diodes in a voltage-doubler circuit for low heat and high efficiency.

The low-silhouette styling and attractive front panel will prove an attractive addition to any surroundings.

INTRODUCTION TO RADIO

Radio is a system of sending and receiving signals, messages, speech, music, and other information by the use of electromagnetic waves, without any connecting wires.

When an announcer speaks into a microphone in a radio broadcast station, the sound waves created by his voice are picked up by the microphone and changed into electrical impulses. See Figure 1. The weak electrical impulses from the microphone are then fed into a transmitter. The transmitter amplifies the weak signals from the microphone and transforms them into electrical waves that can be fed to a transmitting antenna and radiated through space. Similarly, when the amateur radio operator talks into a microphone, the weak electrical impulses from the microphone are fed into a transmitter. The signal from the transmitter is then fed into an antenna and radiated through space.

When these electrical signals leave the transmitting antenna, they are called electrical waves. They spread out in all directions, or they may be beamed in one direction, depending on the type of transmitting antenna used.

A receiver antenna picks up a small part of these electrical waves and feeds it into the receiver in the form of an electrical signal. Before this signal can enter the receiver, the receiver must be tuned to the frequency of the transmitted signal.

A receiver must separate one station from another. This is accomplished with tuned circuits which select one station and reject all others. After tuning to the desired radio signal, the radio reduces the frequency of the incoming signal to a constant, intermediate frequency signal.

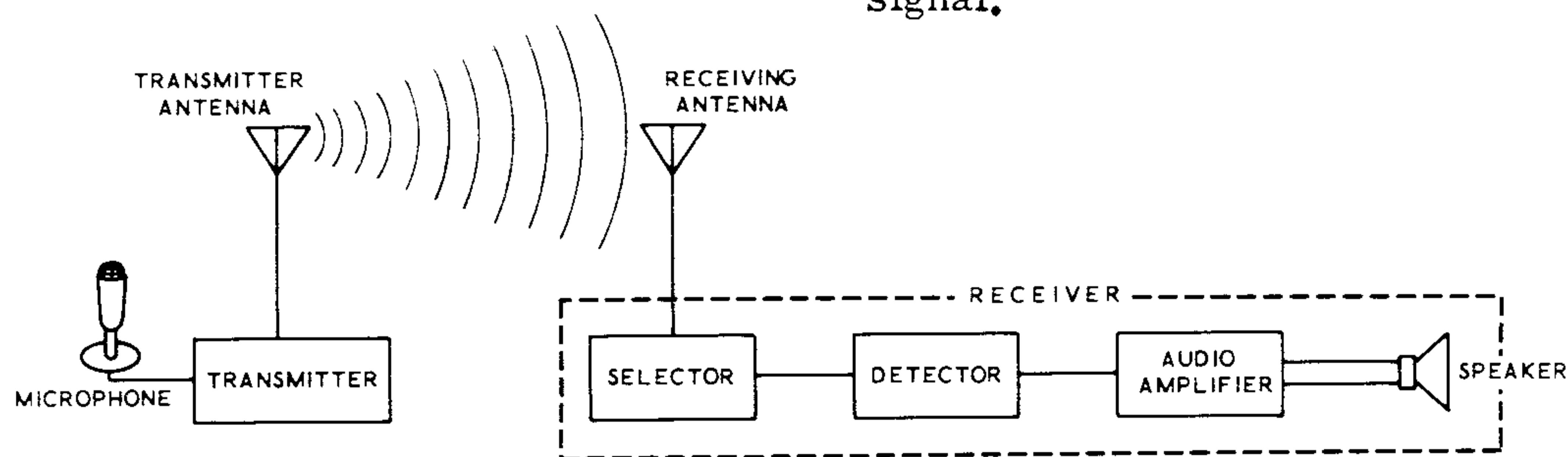

Figure 1

The process of obtaining this intermediate frequency signal requires three functions; oscillation, mixing, and detection. An oscillator circuit, generally called a local oscillator, sets up a signal that differs in frequency from the signal frequency. A mixer is required to obtain a new intermediate frequency by combining the signal frequency with that of the local oscillator through heterodyne or mixing action.

When the incoming electrical signal and the oscillator signals are combined, the output of the mixer contains many frequencies. The output of the mixer is fed directly to a highly selective amplifier, called an intermediate frequency or IF amplifier. This IF amplifier

accepts only one frequency, amplifies it, and rejects all other frequencies. From the IF amplifier, the signal is fed to the audio detector.

The audio detector separates the audio frequency signal from the IF signal. Therefore, the output of the audio detector is an audio signal. This is where the announcer's voice, or the orchestra is restored to its original form. This signal is very weak.

From the audio detector the audio signal is fed to an audio amplifier which amplifies the signal so it can drive headphones or a loudspeaker. The loudspeaker converts the electrical audio signal into sound waves that can be heard.

CIRCUIT DESCRIPTION

Refer to the Schematic (fold-out from Page 43) and Block Diagrams while reading the following description for a more thorough understanding of the circuit. The signal path will be described with the switches in their fully counterclockwise position. This is the position in which the switches are shown on the Schematic Diagram.

When the Band switch is in position A, the radio station signal is received by the band A rod antenna coil, rear half of wafer A on the Band Switch, and then coupled through capacitor C14 and resistor R1 to the grid of the mixer-oscillator tube V1. Tube V1 combines the received radio signal and the oscillator signal. This produces a difference frequency of 455 kc. The 455 kc frequency is called the Intermediate Frequency (IF). The oscillator signal is varied along with the radio signal so that the difference between these signals is always 455 kc. The oscillator frequency is varied by one-half of Main Tuning capacitor C7 and the proper oscillator coil selected by Band switch wafer B.

The 455 kc IF signal from the plate of V1 is coupled through IF transformer IF-1 to the grid of the IF amplifier tube V2. IF transformer IF-1 is tuned so that it will pass only the 455 kc IF signal and reject all others. The IF signal is amplified by IF amplifier stage V2 and coupled through IF transformer IF-2 to the detector tube V3. Tube V2 also acts as a Beat Frequency Oscillator (BFO). The output signal of the BFO is used for Carrier Wave (CW) and Single Side Band (SSB) reception.

Tube V3 is a combination detector, audio amplifier, and an automatic noise limiter (ANL). The audio portion of the 455 kc IF signal is removed by the detector action of V3. This audio signal is amplified by the audio amplifier section of V3 and coupled through capacitor C26 to the grid of the audio output tube V4. The amount of amplification in tube V3 is controlled by the setting of Volume control R13 which is in the detector circuit of V3.

In audio output stage V4, the audio signal is greatly amplified and applied through audio output transformer T2 to the speaker.

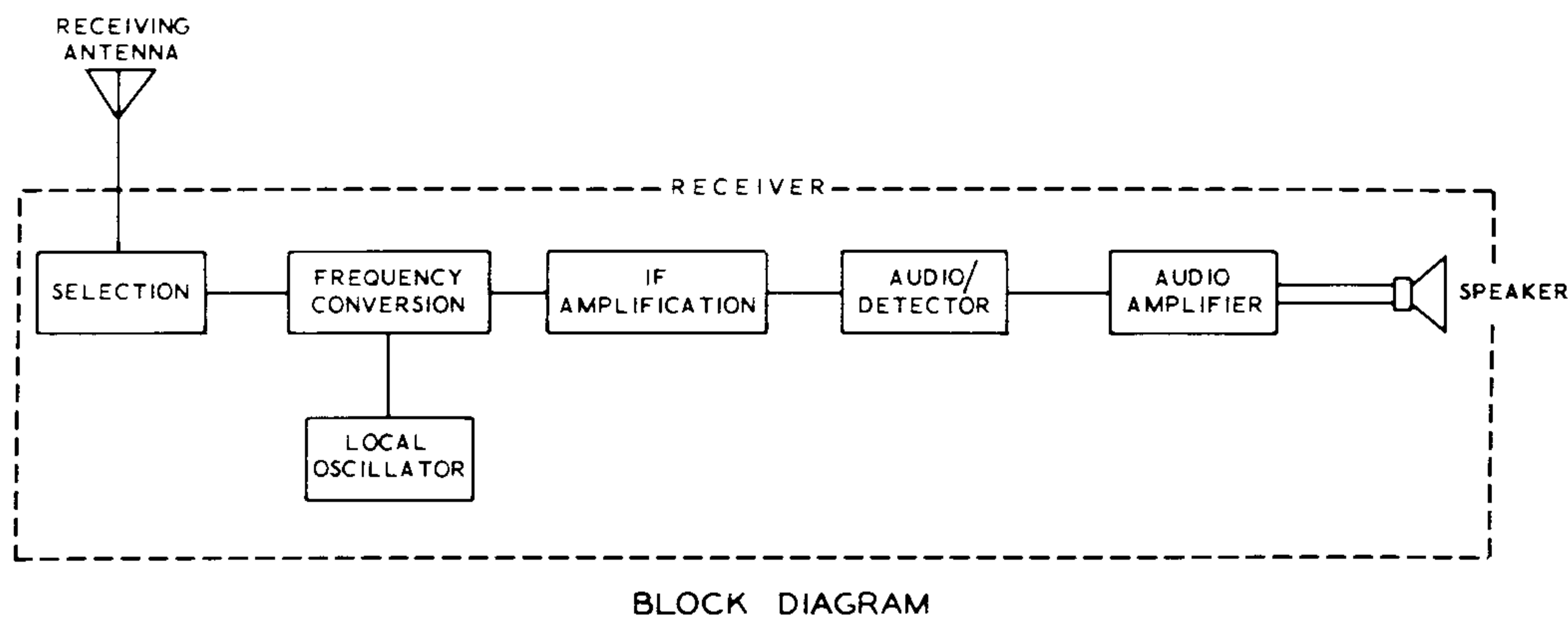

Figure 2

The power supply consists of diodes D1 and D2, capacitors C27C, C29, and C30, and power transformer T1 connected in a voltage-doubler circuit.

The B+ voltage is filtered by resistor R20 and capacitor C27B. The tube filaments are operated from a 12 volt winding on power transformer T1.

CONSTRUCTION NOTES

This manual is supplied to assist you in every way to complete your kit with the least possible chance for error. The arrangement shown is the result of extensive experimentation and trial. If followed carefully, the result will be highly stable and dependable performance. We suggest that you retain the manual in your files for future reference, both in the use of the equipment and for its maintenance.

UNPACK THE KIT CAREFULLY AND CHECK EACH PART AGAINST THE PARTS LIST. In so doing, you will become acquainted with the parts. Refer to the information on the inside covers of the manual to help you identify the components. If some shortage or parts damage is found in checking the Parts List, please read the Replacements section and supply the information called for therein.

Resistors generally have a tolerance rating of 10% unless otherwise stated in the Parts List. Tolerances on capacitors are generally even greater. Limits of +100% and -20% are common for electrolytic capacitors.

We suggest that you do the following before work is started:

1. Lay out all parts so that they are readily available.
2. Provide yourself with good quality tools. Basic tool requirements consist of a screwdriver with a 1/4" blade; a small screwdriver with a 1/8" blade; long-nose pliers; wire cutters, preferably separate diagonal cutters; a penknife or a tool for stripping insulation from wires, and a soldering iron (or gun). A set of nut drivers, while not necessary, will aid extensively in construction of the kit.

Most kit builders find it helpful to separate the various parts into convenient categories. Muffin tins or molded egg cartons make convenient trays for small parts. Resistors and capacitors may be placed with their lead ends inserted in the edge of a piece of corrugated cardboard until they are needed. Values can be written on the cardboard next to each component. The illustration shows one method that may be used.

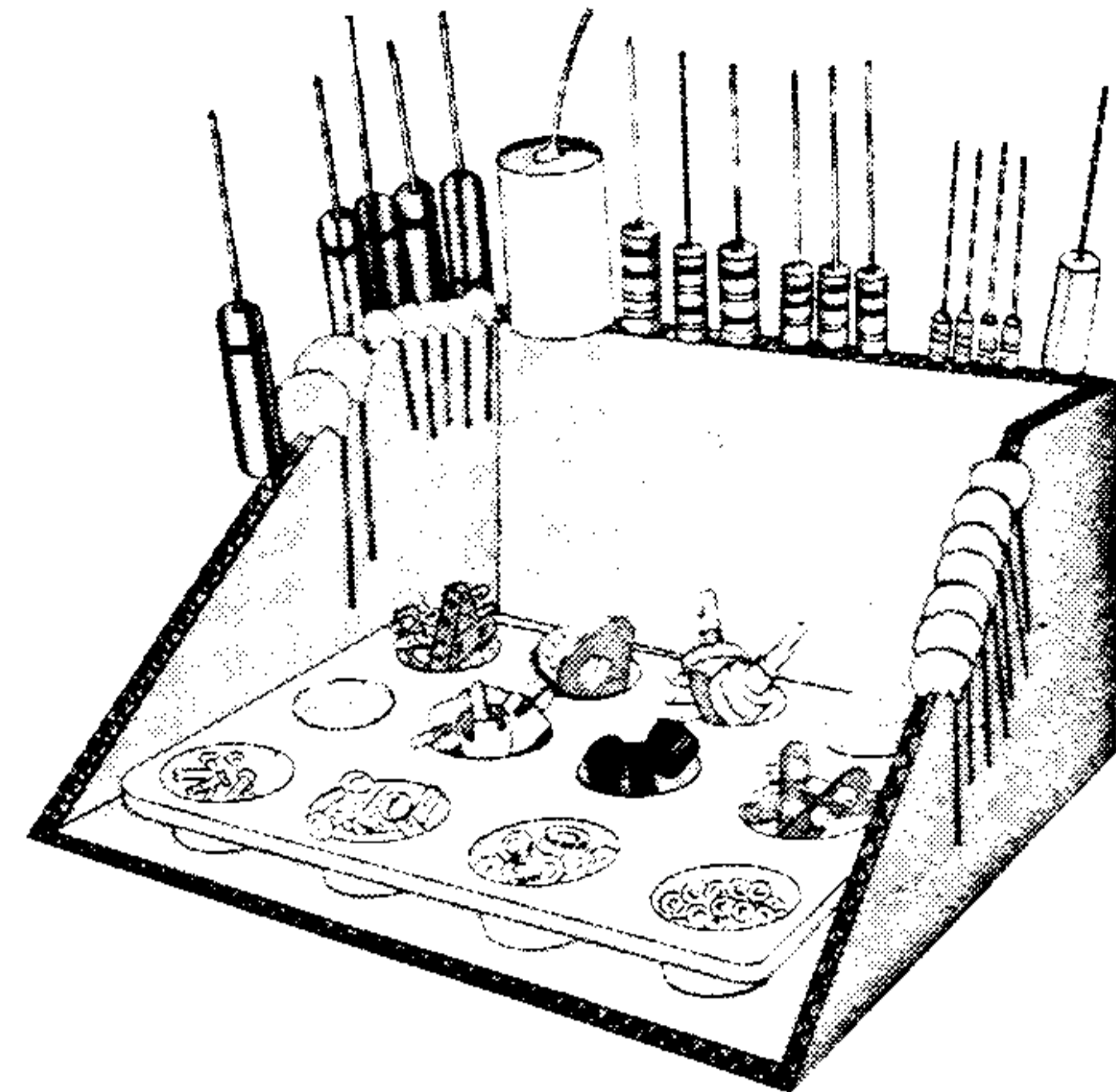

PARTS LIST

NOTE: The numbers in parentheses in the Parts List are keyed to the numbers on the Parts Pictorial (fold-out from Page 13) to aid in parts identification.

<u>PART No.</u>	<u>PARTS Per Kit</u>	<u>DESCRIPTION</u>	<u>PART No.</u>	<u>PARTS Per Kit</u>	<u>DESCRIPTION</u>
RESISTORS (1/2 Watt)			CAPACITORS (Disc)		
(1) 1-2	1	68 Ω (blue-gray-black)	(6) 21-78	1	5 μuf
1-3	5	100 Ω (brown-black-brown)	21-86	1	75 μuf
1-66	1	150 Ω (brown-green-brown)	21-9	1	100 μuf
1-9	1	1000 Ω (brown-black-red)	21-22	1	220 μuf
1-109	1	12 KΩ (brown-red-orange)	21-13	1	500 μuf
1-22	1	22 KΩ (red-red-orange)	21-27	4	.005 μfd
1-25	2	47 KΩ (yellow-violet-orange)	21-16	8	.01 μfd
1-60	2	68 KΩ (blue-gray-orange)	21-31	2	.02 μfd
1-29	1	220 KΩ (red-red-yellow)	CAPACITORS (Other)		
1-33	3	470 KΩ (yellow-violet-yellow)	(7) 25-119	1	60-20-20-10 μfd at 350, 250, and 150 V electrolytic
1-37	1	2.2 megohm (red-red-green)	(8) 25-43	1	70 μfd at 350 V electrolytic
1-38	1	3.3 megohm (orange-orange-green)	(9) 26-81	1	355 μuf variable
1-40	1	10 megohm (brown-black-blue)	26-88	1	5.9 μuf variable
RESISTORS (1 Watt - 2 Watt)			(10) 31-8	3	1-10 μuf trimmer
(2) 1A-20	1	330 Ω 1 watt (orange-orange-brown)	(11) 31-23	1	2-60 μuf dual section trimmer
1A-2	1	1000 Ω 1 watt (brown-black-red)	CONTROLS-SWITCHES		
(3) 1B-16	1	330 Ω 2 watt (orange-orange-brown)	(12) 10-27	1	3000 Ω control
CAPACITORS (Resin-Mica)			19-26	1	1 megohm control with SPST switch
(4) 20-52	1	7.5 μuf resin	(13) 60-1	1	SPST switch
(5) 20-34	1	350 μuf mica	(14) 63-53	1	3-position switch (Function)
20-35	1	910 μuf mica (.00091)	63-286	1	4-position, 2-section switch (Band)
20-57	1	2000 μuf mica (.002)			

PART No.	PARTS Per Kit	DESCRIPTION	PART No.	PARTS Per Kit	DESCRIPTION
COILS-CHOKE-TRANSFORMERS			HARDWARE (cont'd.)		
(15) 40-397	1	Band A oscillator coil	(37) 250-100	2	6-32 x 5/16" setscrew
40-398	1	Band B oscillator coil	(38) 252-7	6	Control nut
40-399	1	Band C oscillator coil	(39) 252-3	20	6-32 nut
40-400	1	Band D oscillator coil	(40) 252-1	16	3-48 nut
40-615	1	Band B antenna coil	(41) 252-22	4	6-32 speednut
40-616	1	Band C antenna coil	(42) 253-10	5	Control flat washer
40-617	1	Band D antenna coil	(43) 253-27	4	#6 flat steel washer
(16) 40-618	1	Band A rod antenna coil	(44) 253-36	1	Formed spring washer
(17) 45-27	1	30 mh RF choke	(45) 254-5	3	Control lockwasher
(18) 51-55	1	Audio output transformer	(46) 254-1	23	#6 lockwasher
(19) 52-84	2	IF transformer	(47) 254-7	16	#3 lockwasher
54-155	1	Power transformer	(48) 259-10	2	Control solder lug
DIODES-TUBES-LAMPS			(49) 259-1	4	#6 solder lug
57-27	2	Silicon diode	(50) 253-11	1	E ring
411-50	1	12BE6 tube	(51) 255-3	3	#6 spacer
411-51	1	12BA6 tube	(52) 258-1	2	Dial cord spring
411-52	1	12AV6 tube	(53) 453-110	1	Dial drive shaft
411-203	1	12AQ5 tube	(54) 454-12	1	Flywheel
(21) 412-20	2	#47 pilot lamp	(55) 455-9	1	1/4" brass bushing
TERMINAL STRIPS-SOCKETS-JACK			METAL PARTS		
(22) 431-8	1	3-lug screw type terminal strip	90-M288F	1	Cabinet
(23) 431-10	1	3-lug terminal strip	200-M411	1	Chassis
(24) 431-11	1	5-lug terminal strip	(56) 204-M628	1	Switch mounting bracket
(25) 434-80	2	7-pin tube socket with center pin	(57) 204-M636	1	Dial drive mounting bracket
(26) 434-112	2	7-pin tube socket without center pin	100-M573F	1	Dial back plate
434-88	2	Pilot lamp socket	205-M453	1	Bottom plate
(27) 436-4	1	Phone jack	MISCELLANEOUS		
INSULATORS-WIRES-CABLE			85-95P69	1	Circuit board
73-1	2	3/8" rubber grommet	94-406	1	Cabinet back panel
73-4	1	5/16" rubber grommet	(58) 100-M19	1	Bandspread dial pulley
(28) 75-24	1	Line cord strain relief	100-M70	1	Main dial pulley
89-1	1	Line cord	100-M356	1	Dial cord assembly
340-2	1	Bare wire	349-1	1	Dial cord
344-50	1	Black hookup wire	205-463	1	Plastic decorative panel
344-59	1	White hookup wire	206-77	2	Tube shield
347-9	1	3-wire shielded cable	(59) 207-4	1	1/4" cable clamp
HARDWARE			207-18	2	3/8" cable clamp
(29) 250-26	3	6-32 x 5/8" screw	(60) 261-16	2	Short plastic feet
(30) 250-89	10	6-32 x 3/8" screw	261-17	2	Long plastic feet
(31) 250-32	2	6-32 x 3/8" flat head screw	(61) 259-20	22	Terminal pins
(32) 250-56	14	6-32 x 1/4" screw	401-24	1	Speaker
(33) 250-116	4	6-32 x 1/4" truss head screw (black)	407-68	1	Meter
(34) 250-49	16	3-48 x 1/4" screw	(62) 462-140	2	Large knob
(35) 250-8	17	#6 x 3/8" sheet metal screw	462-159	4	Small knob
(36) 250-16	2	8-32 x 3/16" setscrew	(63) 463-22	1	Vernier dial pointer
			463-30	1	Main dial pointer
			464-42	1	Dial window
			(64) 481-1	1	Capacitor mounting wafer
			(65) 490-1	1	Alignment tool
			490-5	1	Nut starter
			336-1		Solder
			595-702	1	Manual

RESISTANCE MEASUREMENTS AND INITIAL TEST

RESISTANCE MEASUREMENTS

Refer to Pictorial 6 (fold-out from Page 25) for the following steps.

If an ohmmeter is available, it would be well to make the following resistance checks before turning on the Receiver for the first time.

If any of the following resistance measurements are not correct, refer to the In Case Of Difficulty section of the manual.

(·) Measure the resistance from lug 1 and from lug 5 of terminal strip F to the chassis. Both of these measurements should be at least 15 megohms.

(^) Measure the resistance between lugs 1 and 5 of terminal strip F. This resistance should be approximately 8Ω with the VOLUME control switch ON.

(^) Measure the resistance between lug 3 of electrolytic capacitor K and the chassis. This measurement should be over $25 K\Omega$.

Refer to Pictorial 12 for the following steps.

() Install the bottom panel on the chassis, using eleven #6 x $3/8$ " sheet metal screws.

() Connect the white wire of the twisted pair extending from the chassis to lug 1 (S-1) and the black wire to lug 2 (S-1) of the speaker.

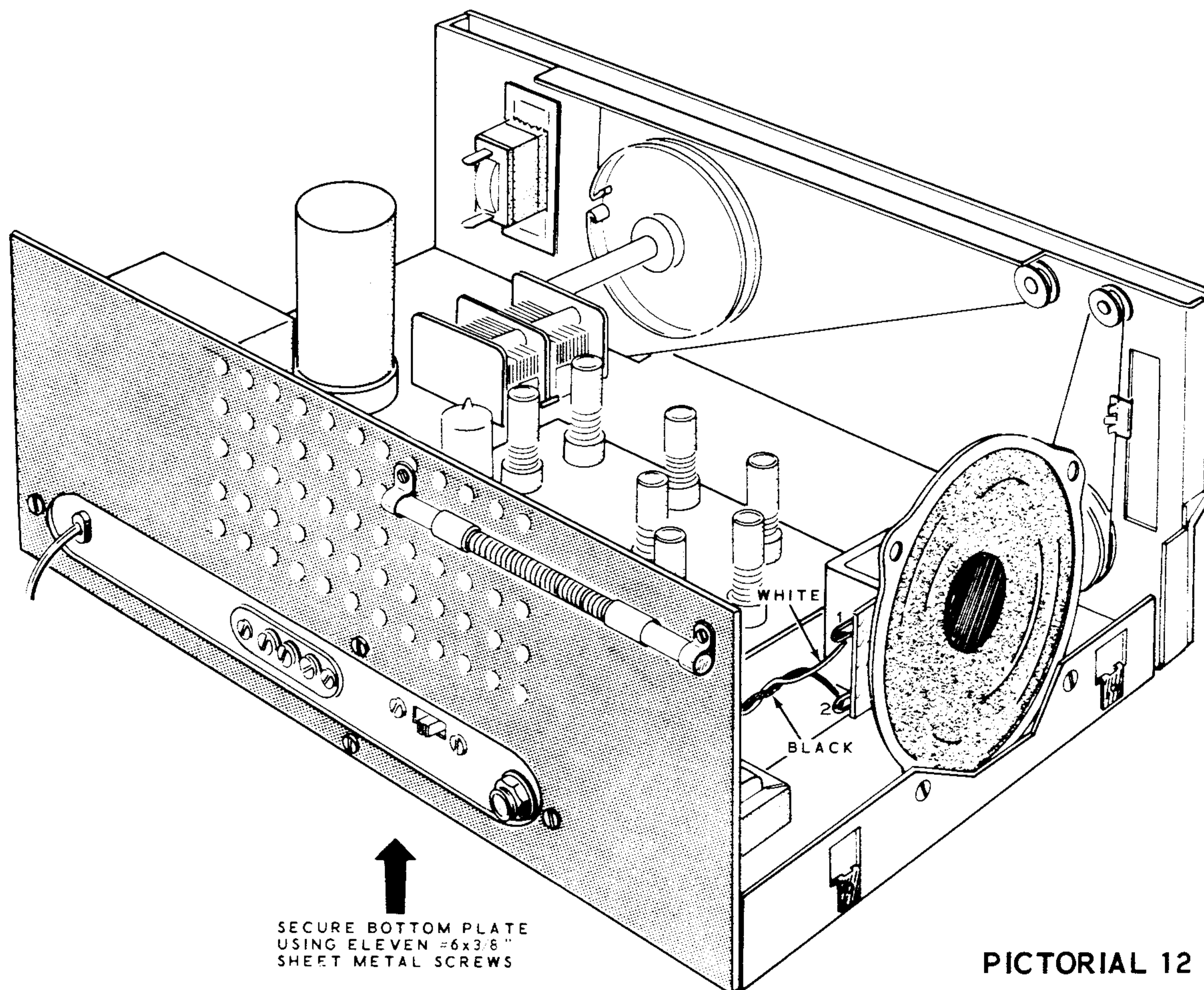

PICTORIAL 12



- () Insert all tubes in their proper sockets on the circuit board. The tube type number appears near each tube socket on the circuit board.
- () Turn all the front panel control shafts fully counterclockwise.
- () Install the two large knobs, one on the MAIN TUNING capacitor shaft and the other knob on the BANDSPREAD capacitor shaft.
- () Install the four small knobs on the shafts. Position the pointers to the counterclockwise front panel marking for each shaft.
- () Set the BAND switch to BAND A.
- () Place your finger on or connect a short length of wire to the ANT terminal on the rear of the Receiver.
- () Some broadcast stations should be heard by tuning across the dial.
- () Similarly, switch the BAND switch through the remaining three bands, checking for any stations that you may pick up.
- () Turn the Function switch to the STBY position. The pilot lamps and filaments should still be on but no stations or background noise should be heard from the speaker.

INITIAL TEST

- () Plug the line cord plug into an electrical outlet, 105-125 volts, 50/60 cps AC only.

NOTE: If any of the following tests do not produce the desired results refer to the In Case Of Difficulty section.

- () Turn the Receiver on with the VOLUME control. Check to see that the two pilot lamps light and the tube filaments in the four tubes glow.
- () Turn the VOLUME control clockwise and listen for a background noise from the speaker.
- () Turn the Function switch to the CW position and turn the BFO control to its 12 o'clock position.
- () By tuning across the higher bands (B, C, and D), some CW stations may be heard.
- () Turn the Receiver off and install tube shields over V2 and V3. Make sure the shield slips over the shield clip on each tube socket.
- () Disconnect the antenna wire if one was used.

ALIGNMENT

Before attempting alignment, operate the Receiver for a minimum of 15 minutes to allow the tubes and components to stabilize. For best results, alignment should be done with test instruments. However, if the following instruments are not available, refer to Alignment Without Instruments on Page 37. A plastic alignment tool is provided to align the coils.

The following test instruments will be needed for the following steps.

Signal Generator
VTVM

ALIGNMENT WITH INSTRUMENTS

Refer to Figure 3 (fold-out from Page 37) for the following steps.

- () Preset the adjusting screws in the A, B, and C TRIMMERS as shown in Figure 3.
- () Preset the B and C antenna trimmers, located on the chassis, by turning the screws clockwise until they are snug. Then turn the B and C antenna trimmer screws counterclockwise 1-2/3 turns.
- () Remove the screw from the oscillator trimmer located on the MAIN TUNING capacitor. Carefully bend the brass strap out 90 degrees from the capacitor, as shown.

- () Set the front panel controls as follows:

BANDSPREAD - 10.

VOLUME - 12 o'clock.

(Adjust as necessary during alignment)

Function - AM.

BAND - B.

BFO - OFF.

MAIN TUNING - 1.5 MC.

ANL (on rear apron) - OFF.

- () Connect the common VTVM lead to the chassis and the DC test lead to the AVC terminal pin on the topside of the circuit board. Set the VTVM to read -DC volts on the 15 volt scale.
- () Connect the common lead of the signal generator to the chassis and the signal lead to the ANT terminal on the rear of the chassis. Set the signal generator for a 455 kc unmodulated signal.
- () Adjust the generator output until an increase in the voltage reading is indicated on the VTVM. Set the generator output to the lowest level that still provides a usable voltage reading on the lowest VTVM range.
- () During alignment, reduce the signal generator output as the VTVM readings become higher. Always use the lowest signal generator output possible and still have a readable voltage on the lowest VTVM range.

Proceed with alignment, using the Alignment Chart.

ALIGNMENT CHART

	TUNE SIGNAL GENERATOR TO:	SET BAND SWITCH TO:	SET RECEIVER DIAL TO:	ADJUST FOR MAXIMUM VTVM READING:
1.	455 kc	B	1.5 mc	IF-1 top and bottom.
2.	455 kc	B	1.5 mc	IF-2 top and bottom.
3.	Repeat steps 1 and 2.			
	NOTE: It may be necessary to use a high signal output from the generator for steps 4 - 6.			
4.	550 kc	A	550 kc	A OSC coil.
5.	1.5 mc	A	1.5 mc	A TRIMMER and the Antenna trimmer on the MAIN TUNING capacitor.
6.	550 kc	A	550 kc	A OSC coil.
7.	Repeat steps 4 through 6 until no improvement is noticed.			
8.	10 mc	D	10 mc	D OSC and D ANTENNA coils. NOTE: It should not be necessary to turn this coil more than 1/2 turn in either direction.
9.	Tune the Receiver to 9,090 mc and check for the image frequency. If the image frequency does not appear at this point, repeat steps 5 through 9, being careful to align to the correct frequency. The image frequency is 910 kc below the signal frequency on Bands A, B, and C.			
10.	4 mc	C	4 mc	C OSC and C ANTENNA coils.
11.	10 mc	C	10 mc	C BAND trimmer and Ant trimmer on chassis.
12.	4 mc	C	4 mc	C OSC and C ANTENNA coils.
13.	Repeat steps 10 through 12 until no further improvement is noticed.			
14.	1.5 mc	B	1.5 mc	B OSC and B ANTENNA coils.
15.	4 mc	B	4 mc	B BAND trimmer and Ant trimmer on chassis.
16.	1.5 mc	B	1.5 mc	B OSC and B ANTENNA coils.
17.	Repeat steps 14 through 16 until no further improvement is noticed.			

This completes the alignment with instruments.
Proceed to Cabinet Installation.

ALIGNMENT WITHOUT INSTRUMENTS

Refer to Figure 3 for the following steps.

- () Preset the adjusting screws in the A, B, and C TRIMMERS as shown in Figure 3.

- () Preset the B and C Antenna trimmers located on the chassis by turning the screws clockwise until they are snug. Then turn the B and C Antenna trimmer screws counter-clockwise 1-2/3 turns.

- () Remove the screw from the oscillator trimmer located on the MAIN TUNING capacitor. Carefully bend the brass strap out 90 degrees from the capacitor, as shown. Discard the mica insulator and screw as they are not needed.

- () Set the front panel controls as follows:

BANDSPREAD - 10
VOLUME - 12 o'clock (adjust as necessary during alignment).
Function - AM.
BAND - A.
BFO - OFF.
MAIN TUNING - Radio station of known frequency near 550 kc.
ANL (on rear apron) - OFF.

- () With a radio station of known frequency near 550 kc tuned in, adjust A OSC coil and retune the Receiver until the station is received when the dial pointer indicates the frequency of the radio station.

- () With a radio station near 550 kc tuned in, adjust the top and bottom slugs of IF-1 and IF-2 transformers for a maximum meter reading.

The coils for the other bands are preset at the factory and should not be readjusted without test instruments. The preset coil settings will provide adequate reception.



CABINET INSTALLATION

() Refer to Pictorial 13 and install the cabinet over the Receiver chassis. Secure the cabinet with two 6-32 x 1/4" black screws on each side with the back panel inside the cabinet.

NOTE: The blue and white identification label shows the Model Number and Production Series Number of your kit. Refer to these numbers in any communications with the Heath Company; this assures you that you will receive the most complete and up-to-date information in return.

() Install the identification label in the following manner:

1. Select a location for the label where it can easily be seen when needed, but will not show when the unit is in operation. This location might be on the rear panel or the top of the chassis, or on the rear or bottom of the cabinet.
2. Carefully peel away the backing paper. Then press the label into position.

OPERATION

Before attempting to use the Receiver, carefully read the explanation of each control and learn its function.

CONTROLS

VOLUME - Turns the Receiver on or off and varies the loudness of the sound from the speaker or headphone.

BFO - Turn the BFO on or off and varies the tone of the CW signal when the FUNCTION switch is in the CW position. This control is also useful when tuning weak AM stations.

FUNCTION - Selects AM, STBY, or CW modes of reception. In the AM position the AVC voltage is on; in the CW position the AVC voltage is off. In the STBY position the Receiver is kept warmed up and ready for instant use but it is kept muted.

BAND - Selects one of four bands: A, B, C, or D.

MAIN TUNING - Provides a means of tuning the Receiver, to the desired station.

BANDSPREAD - Provides a fine tuning to the MAIN TUNING capacitor to help separate the incoming signals from each other when they are near the same frequency. This capacitor is normally left in the SET position as it affects the main dial calibration.

AM OPERATION

The BFO control should be in the OFF position. Turn the Function switch to AM and advance the VOLUME control for sufficient volume. Set the BAND switch to the desired band and tune in a station with the MAIN TUNING control.

Turn the BANDSPREAD control until the desired station is centered (that is, for the clearest reception).

When listening to weak stations, turn the BFO ON and slowly adjust this control for the loudest and clearest reception.

CW-SSB OPERATION

Turn the BFO control 3/4 turn clockwise. Turn the Function switch to CW and set the BAND switch to one of the shortwave bands, B, C, or D.

With the MAIN TUNING control, tune in a CW station. Adjust the BFO control as follows: Turn the control fully clockwise and then slowly counterclockwise until the clearest tone is produced. The frequency of this tone may be varied either with the MAIN TUNING or the BANDSPREAD capacitor. Some experimentation will be necessary to find the best position for the BFO control.

When tuning SSB (single side band) signals, tune to the SSB station and then alternate between the BANDSPREAD and BFO controls for the clearest reception.

ANTENNA INSTALLATION

The Receiver must have an antenna for proper shortwave reception. The built-in antenna is for broadcast reception only.

For general broadcast and shortwave listening, a long-wire outside antenna is suggested. A typical long-wire antenna installation is shown in Figure 4. The length of the antenna wire may be from 50 to 100 feet long. The lead-in wire should be attached and soldered to one end of the antenna. The other end of the lead-in wire is connected to the ANT terminal on the rear of the Receiver.

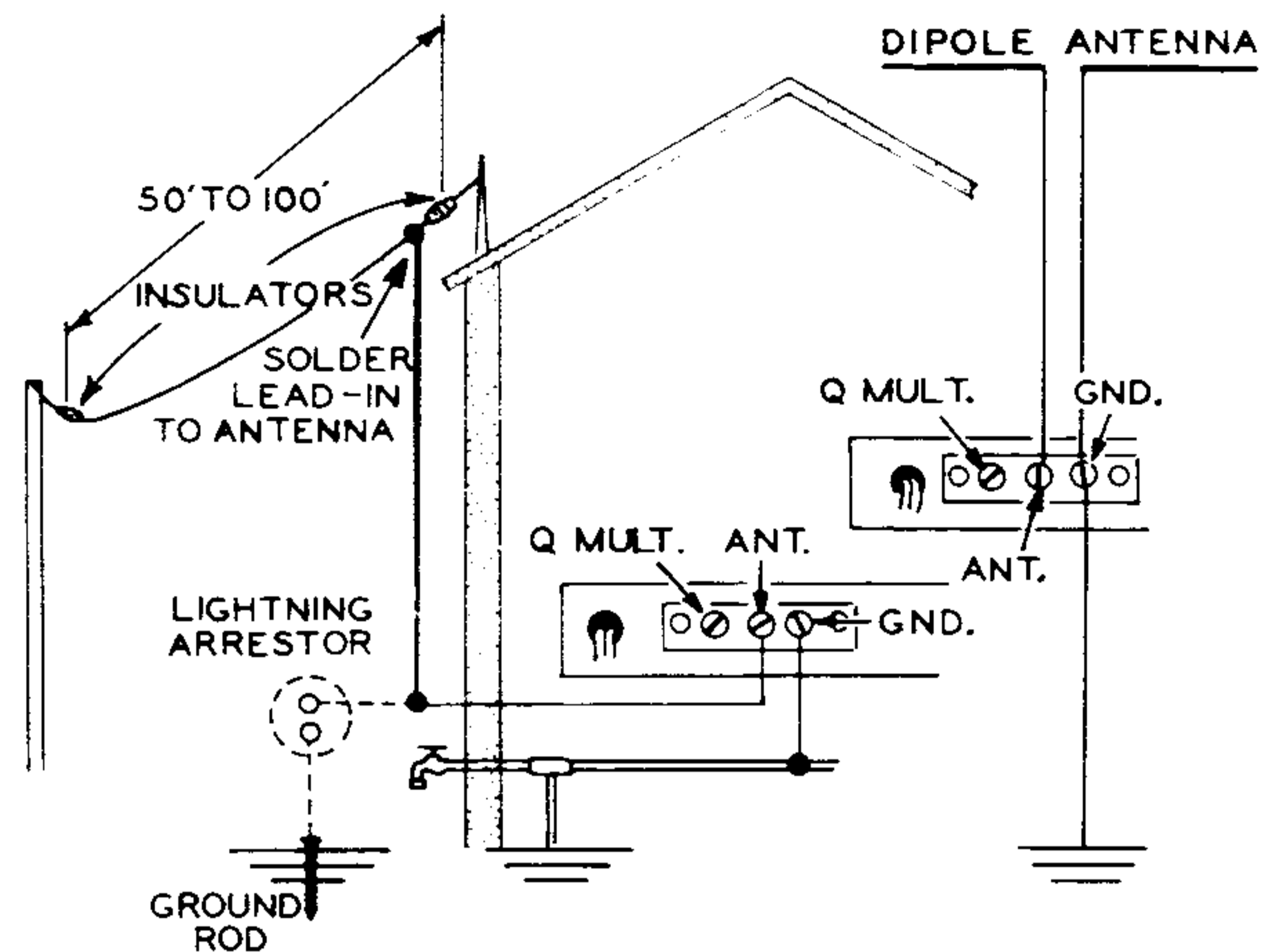

Figure 4

Generally, the higher the antenna the better the reception. A tree or pole may be used as one support and your house as the other support. Insulators must be used at each end of the antenna to separate the antenna wire from the support wire.

The GND terminal on the rear of the Receiver should be grounded to a water pipe or to a 6 or 8 foot long ground rod driven into the earth.

A dipole antenna may be used for optimum reception on the shortwave band. This type of antenna is directional and is designed to receive a narrow band of the shortwave frequencies. It

is suggested you check an ARRL Handbook or an Antenna Handbook for the proper dipole antenna length needed for the shortwave frequencies you intend to listen to.

To connect a dipole antenna to the Receiver, connect the two lead-in wires from the dipole antenna between terminals ANT and GND on the rear of the Receiver. See Figure 4.

RECEPTION GUIDE

<u>BAND</u>	<u>FREQUENCY</u>	<u>TIME</u>	<u>ZONE</u>
80 M	3.5 mc	Morning	Local (Amateur)
49 M	6 mc	Evening	Latin America and Europe
41 M	7 mc	Evening	Europe
40 M	7 mc	Late afternoon, Evening	Europe
40 M	7 mc	Morning	United States (Amateur)
31 M	9 mc	Morning	Asia and Australia
31 M	9 mc	Afternoon	Europe and Africa
31 M	9 mc	Evening	Europe and Latin America
25 M	11 mc	Morning	Asia and Australia
25 M	11 mc	Evening	Latin America
20 M	14 mc	Late morning, Afternoon	United States, Foreign, (Amateur)
19 M	15 mc	Late morning, Afternoon	Europe and North America
19 M	15 mc	Evening	North and Latin America
16 M	17 mc	Afternoon	Europe
	17 mc	All day	United States
	17 mc	Evening	South America
13 M	20 mc	Afternoon	Europe
	20 mc	All day	United States
	20 mc	Evening	South America
11 M	27 mc	All day	Local (Citizen's Band)
10 M	28 mc	Morning	Europe
	28 mc	All day	Central America, United States (Amateur),
		Evening	Asia

These reception conditions prevail in the spring and fall of the year. They are also subject to varying atmospheric conditions, sun spot activities, and to some extent, weather conditions. In the winter, reception generally will be best on the lower frequency bands. In summer, reception will be better on higher frequency bands.

IN CASE OF DIFFICULTY

1. Recheck the wiring. Trace each lead in colored pencil on the Pictorial as it is checked. It is frequently helpful to have a friend check your work. Someone who is not familiar with the unit may notice something consistently overlooked by the constructor.
2. It is interesting to note that about 90% of the kits that are returned for repair, do not function properly due to poor connections and soldering. Therefore, many troubles can be eliminated by reheating all connections to make sure that they are soldered as described in the Proper Soldering Techniques section of this manual.
3. Check to be sure that all tubes are in their proper locations. Make sure that all tubes light up properly.
4. Check the tubes with a tube tester or by substitution of tubes of the same types and known to be good.
5. Check the values of the parts. Be sure that the proper part has been wired into the circuit, as shown in the pictorial diagrams and as called out in the wiring instructions.

6. Check for bits of solder, wire ends or other foreign matter which may be lodged in the wiring.
7. If, after careful checks, the trouble is still not located and a voltmeter is available, check voltage readings against those shown on the Schematic Diagram. NOTE: All

voltage readings were taken with an 11 megohm input vacuum tube voltmeter. Voltages may vary as much as 10%.

8. A review of the Circuit Description will prove helpful in indicating where to look for trouble.

SPECIFIC PROBLEMS	
PROBLEM	CHECK
Filaments do not light.	<ol style="list-style-type: none"> 1. Check filament wiring on bottom of the circuit board against Pictorial 6. 2. Open tube filament - with an ohmmeter, check for continuity between pins 3 and 4 on all four tubes. 3. Check power transformer wiring against Pictorial 6.
Filaments light, but no sound with VOLUME control turned fully clockwise.	<ol style="list-style-type: none"> 1. Make sure the Function switch is not in STBY position. 2. Check wiring between the VOLUME control and the circuit board against Pictorial 6. <p>CAUTION: When making the following checks, do not touch the chassis with your other hand.</p> <ol style="list-style-type: none"> 3. Turn the Receiver on and place a small screwdriver on lug 7 of tube socket V4, then touch your finger to the metal portion of the screwdriver; a low pitched hum should be audible. 4. Now place the screwdriver on lug 1 of tube socket V3. Again touch your finger to the metal portion, this time the hum should be louder. <p>If no hum is present check the circuit board components of tubes V3 and V4 and the wiring to the speaker.</p>
Audio present no signals can be heard.	<p>CAUTION: When making the following tests, do not touch the chassis with your other hand.</p> <ol style="list-style-type: none"> 1. Place a small screwdriver on lug 1 of tube socket V2 and with your finger, touch the metal portion of the screwdriver. A low pitched hum should be heard. <p>If no hum is present, check the circuit board components around tube socket V2.</p> <ol style="list-style-type: none"> 2. Similarly, make the screwdriver test on lug 7 of tube socket V1. The hum should be louder. <p>If no hum is present or if the hum level does not increase, check the components on the circuit around tube socket V1.</p> <ol style="list-style-type: none"> 3. With an ohmmeter, check for continuity from the ANT terminal to ground. The following resistance reading should be obtained for the BAND switch positions. <p style="text-align: center;"> Band A - INF Band B - 1 Ω Band C - 1 Ω Band D - .4 Ω </p>

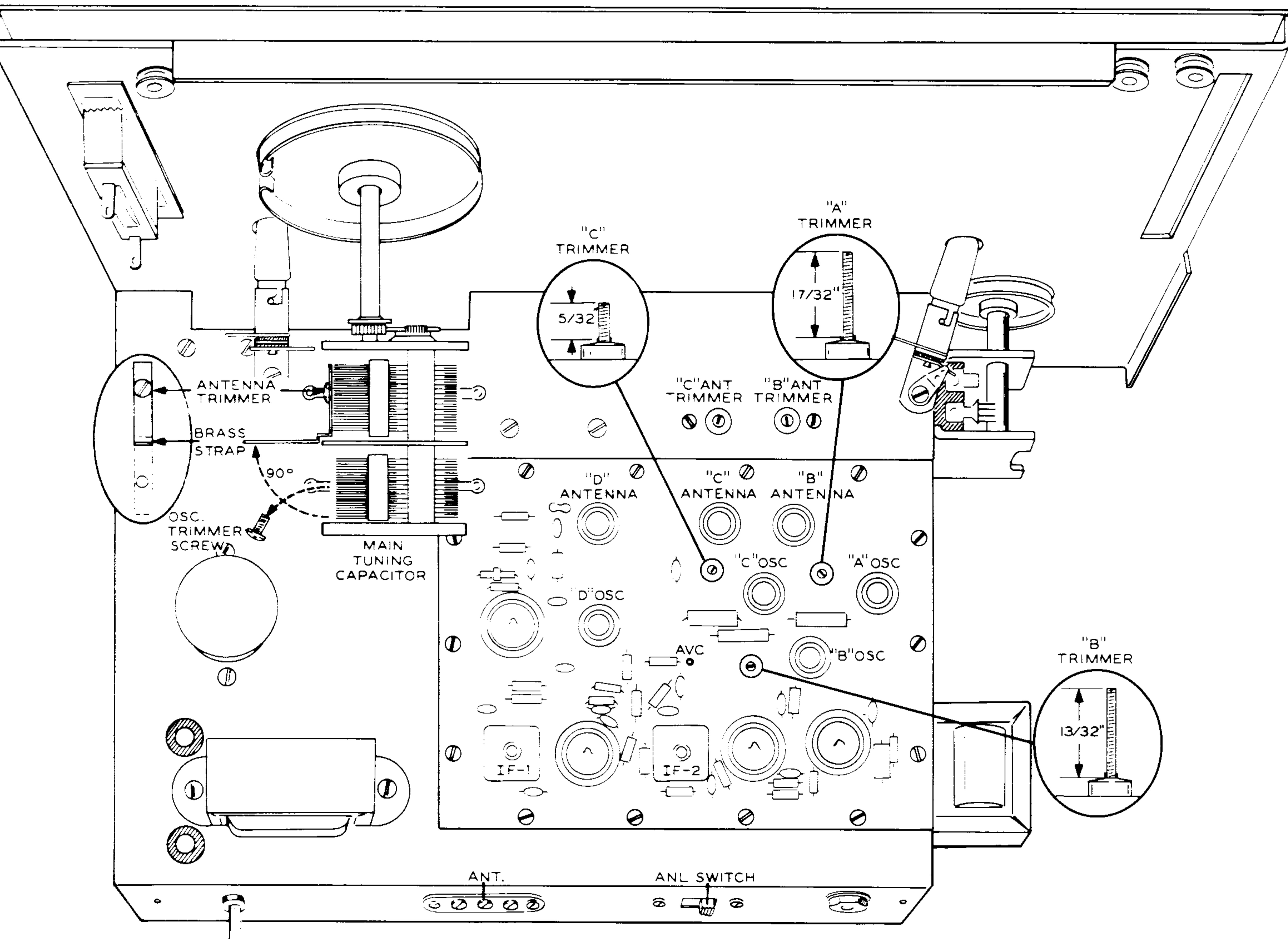
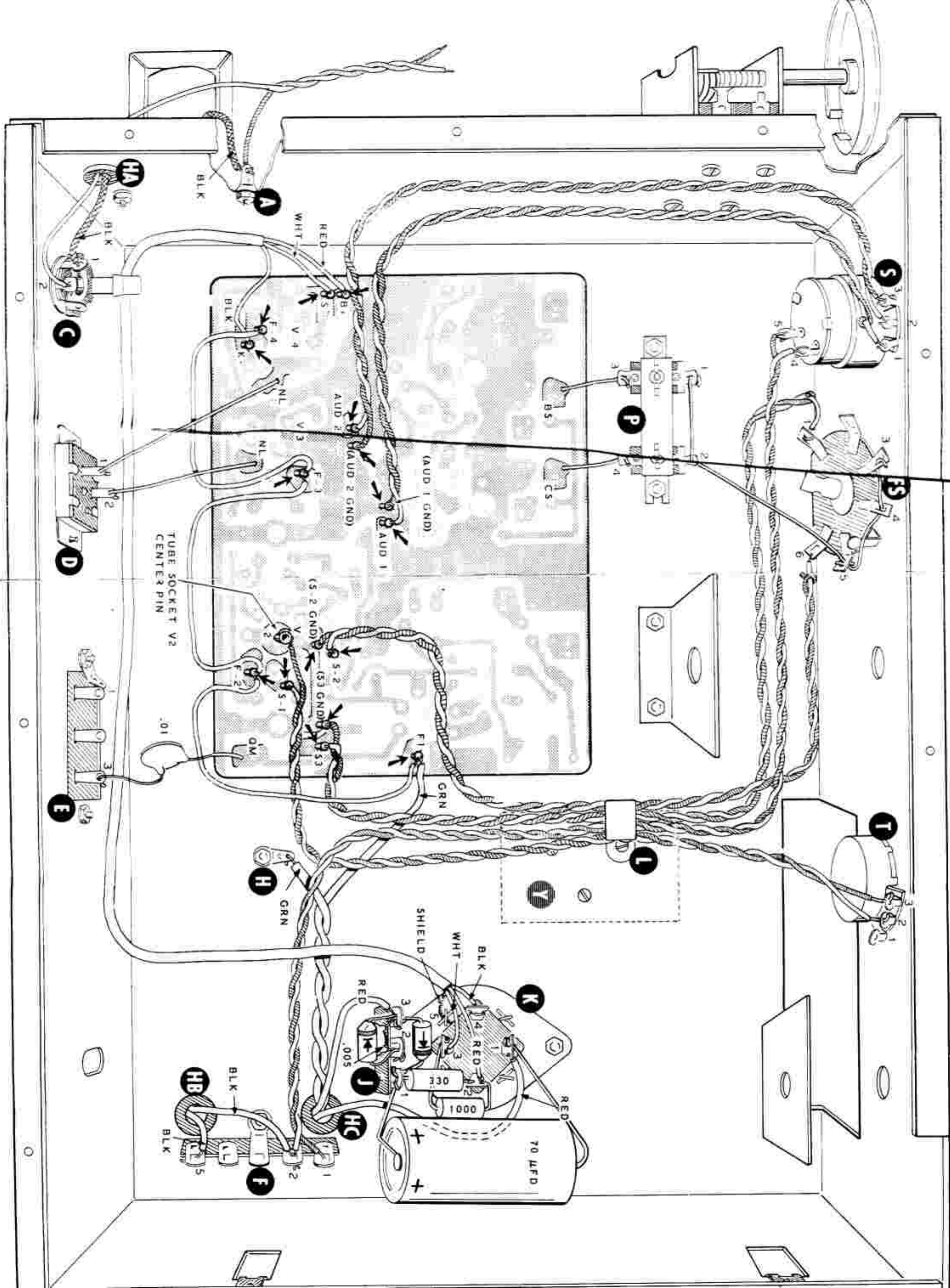
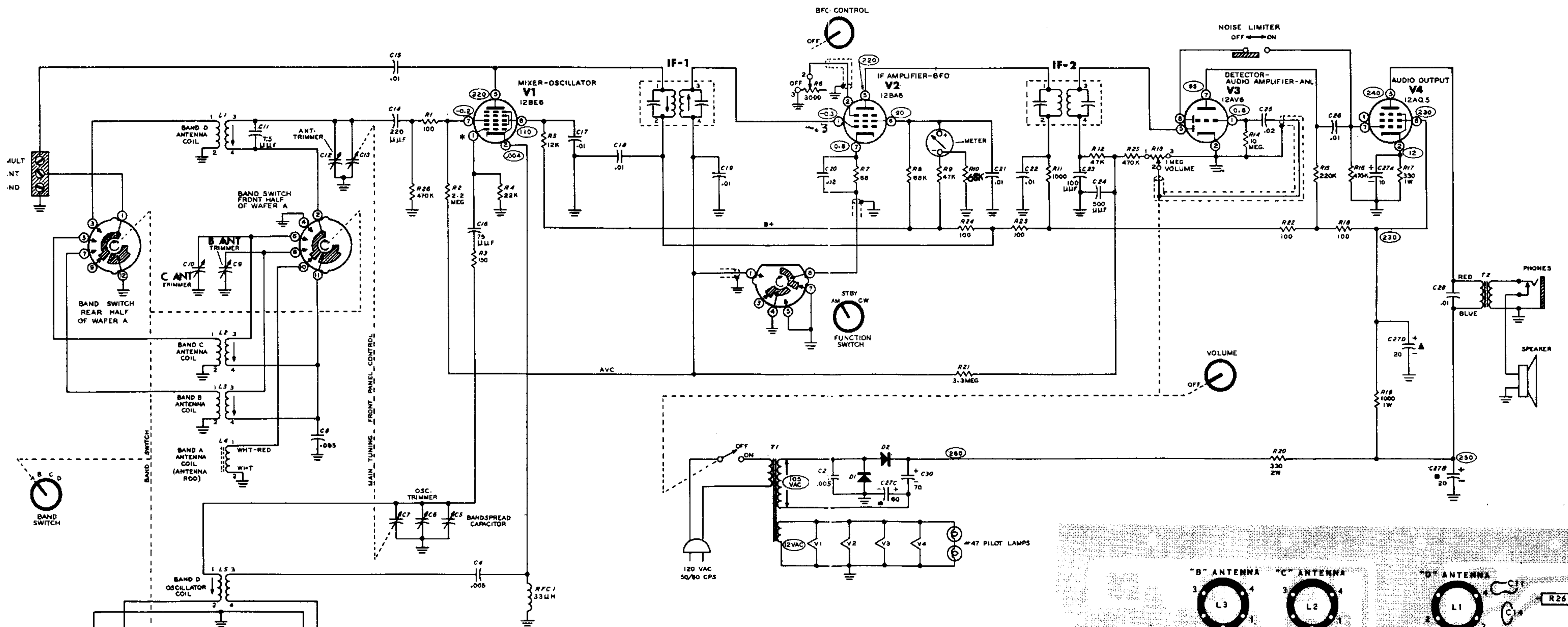

Figure 3



PICTORIAL 6



**SCHEMATIC OF THE
HEATHKIT®
SHORTWAVE RECEIVER
MODEL GR-64**

NOTES:
 ALL RESISTORS ARE 1/2 WATT UNLESS MARKED OTHERWISE.
 ALL RESISTOR VALUES ARE IN OHMS (K = 1,000, MEG = 1,000,000).
 ALL CAPACITOR VALUES ARE IN μM UNLESS OTHERWISE MARKED.
 ○ INDICATES VOLTAGE READING.
 ALL VOLTAGES ARE DC POSITIVE UNLESS MARKED OTHERWISE.
 ALL VOLTAGES ARE MEASURED FROM POINT INDICATED TO CHASSIS GROUND,
 EXCEPT AC VOLTAGES ON POWER TRANSFORMER WINDINGS.
 VOLTAGE READINGS TAKEN WITH AN 11 MEGOHM INPUT VTVM.
 VOLTAGES MAY VARY ±10%.
 VOLTAGES MEASURED WITH THE CONTROLS SET AS FOLLOWS:
 BAND SPREAD - 10 (SET)
 VOLUME - 1/4 CLOCKWISE
 FUNCTION SWITCH-AM
 BAND - BAND A EXCEPT WHERE SHOWN
 BFO - OFF
 MAIN TUNING - 500
 ANL - OFF
 REFER TO THE X-RAY VIEW FOR THE PHYSICAL LOCATION OF PARTS ON
 THE CIRCUIT BOARD.
 ALL SWITCHES VIEWED FROM THE FRONT, AT FULL COUNTERCLOCKWISE
 ROTATION.
 * BAND A - -10
 BAND B - -6.5
 BAND C - -5.3
 BAND D - -5.2

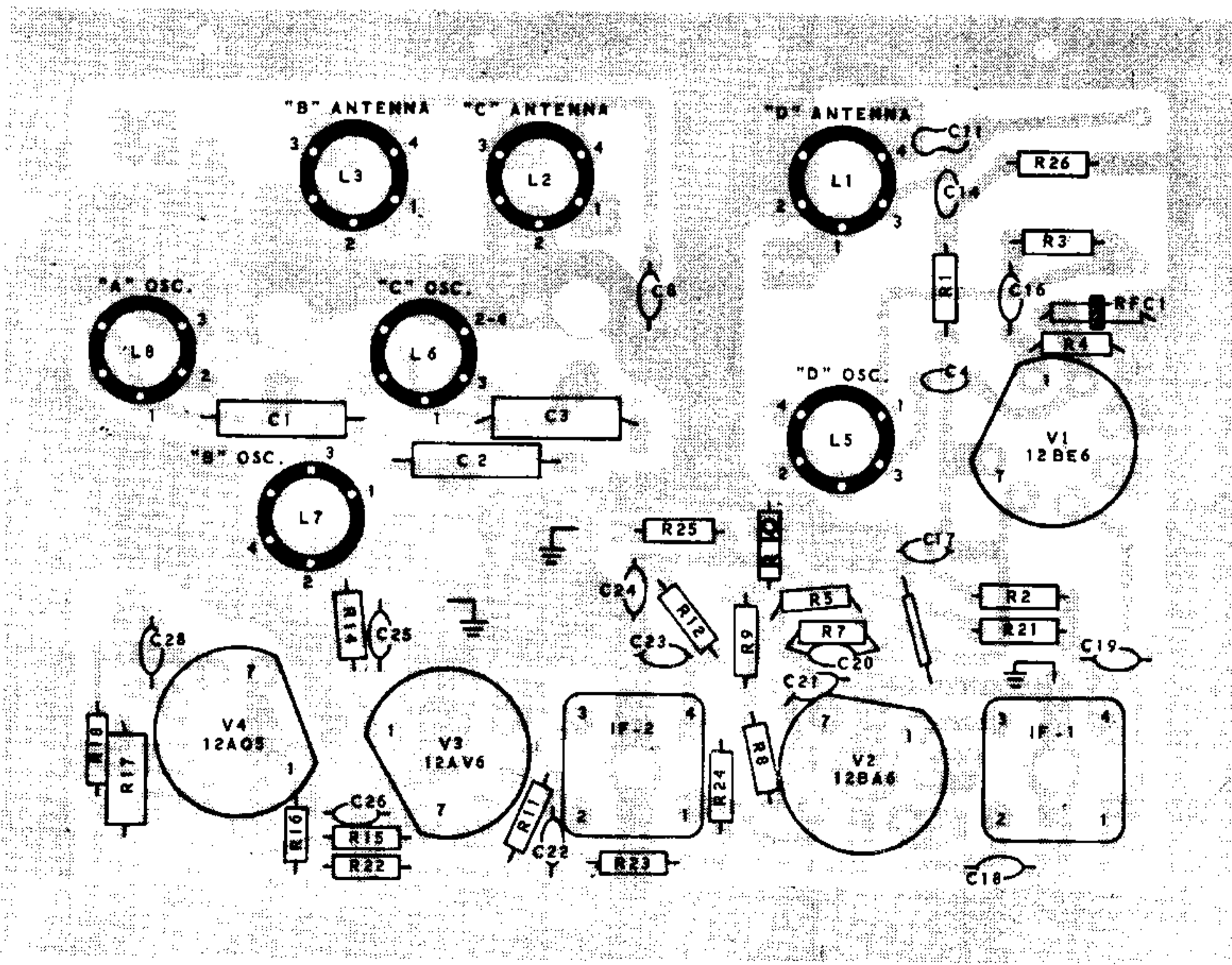



A
B
C
D
L

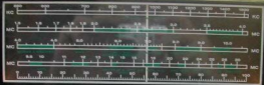

A
B
C
D
L



BANDSPREAD



VOLUME



100V



BAND



BFO



MAIN TUNING



SHORTWAVE  **GRANITE** RECEIVER CR-54

