

PRICE \$1.00

HEATH COMPANY • BENTON HARBOR, MICHIGAN

HEATHKIT® ASSEMBLY MANUAL



PORTABLE
TRANSISTOR RADIO

MODEL GR-24

RESISTOR AND CAPACITOR COLOR CODES

RESISTORS

The colored bands around the body of a color coded resistor represent its value in ohms. These colored bands are grouped toward one end of the resistor body. Starting with this end of the resistor, the first band represents the first digit of the resistance value; the second band represents the second digit; the third band represents the number by which the first two digits are multiplied. A fourth band of gold or silver represents a tolerance of $\pm 5\%$ or $\pm 10\%$ respectively. The absence of a fourth band indicates a tolerance of $\pm 20\%$.

The physical size of a composition resistor is related to its wattage rating. Size increases progressively as the wattage rating is increased. The diameters of 1/2 watt, 1 watt and 2 watt resistors are approximately 1/8", 1/4" and 5/16", respectively.

The color code chart and examples which follow provide the information required to identify color coded resistors.

COLOR	CODE		MULTIPLIER
	1ST DIGIT	2ND DIGIT	
BLACK	0	0	1
BROWN	1	1	10
RED	2	2	100
ORANGE	3	3	1,000
YELLOW	4	4	10,000
GREEN	5	5	100,000
BLUE	6	6	1,000,000
VIOLET	7	7	10,000,000
GRAY	8	8	100,000,000
WHITE	9	9	1,000,000,000
GOLD	-	-	.1
SILVER	-	-	.01

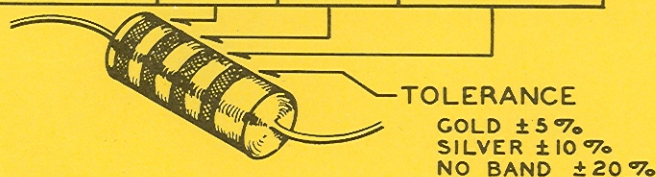

EXAMPLES

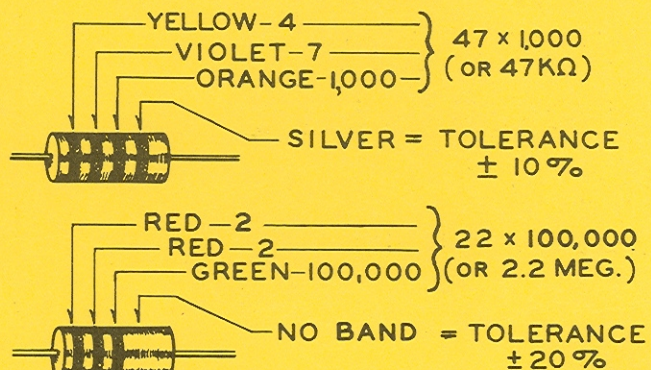

CAPACITORS

Generally, only mica and tubular ceramic capacitors, used in modern equipment, are color coded. The color codes differ somewhat among capacitor manufacturers, however the codes

shown below apply to practically all of the mica and tubular ceramic capacitors that are in common use. These codes comply with EIA (Electronics Industries Association) Standards.

MICA

COLOR	CODE		MULTIPLIER	TOLER. %
	1ST DIGIT	2ND DIGIT		
BLACK	0	0	1	± 20
BROWN	1	1	10	± 20
RED	2	2	100	± 2
ORANGE	3	3	1,000	± 3
YELLOW	4	4	10,000	—
GREEN	5	5	—	± 5
BLUE	6	6	—	—
VIOLET	7	7	—	—
GRAY	8	8	—	—
WHITE	9	9	—	—
GOLD	-	-	.1	—
SILVER	-	-	.01	± 10

EXAMPLE

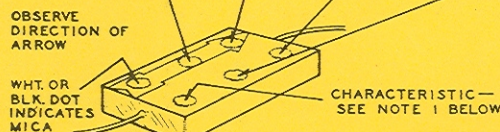
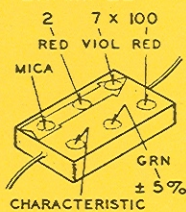

(VALUE IN μf —SEE NOTE 3 BELOW)

1. The characteristic of a mica capacitor is the temperature coefficient, drift capacitance and insulation resistance. This information is not usually needed to identify a capacitor but, if desired, it can be obtained by referring to EIA Standard, RS-153 (a Standard of Electronic Industries Association.)

2. The temperature coefficient of a capacitor is the predictable change in capacitance with temperature change and is

TUBULAR CERAMIC

Place the group of rings or dots to the left and read from left to right.

COLOR	CODE		MULTIPLIER	TOLER. %	
	1ST DIGIT	2ND DIGIT		OR LESS	OR OVER
BLACK	0	0	1	± 20	± 20
BROWN	1	1	10	± 0.1	± 1
RED	2	2	100	—	± 2
ORANGE	3	3	1,000	—	± 2.5
YELLOW	4	4	10,000	—	—
GREEN	5	5	—	± 0.5	± 5
BLUE	6	6	—	—	—
VIOLET	7	7	—	—	—
GRAY	8	8	—	± 0.25	—
WHITE	9	9	—	± 1.0	± 10

EXAMPLE

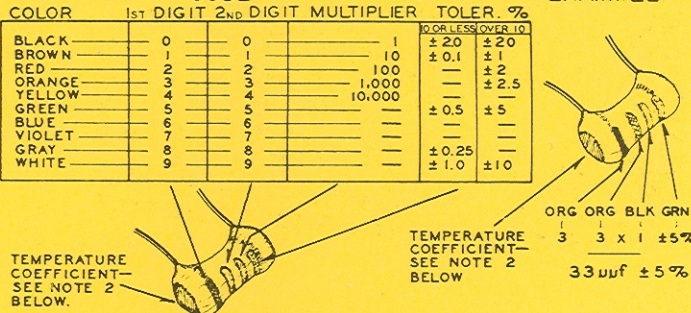

(VALUE IN μf —SEE NOTE 3 BELOW)

TEMPERATURE COEFFICIENT—SEE NOTE 2 BELOW.

NOTES:

expressed in parts per million per degree centigrade. Refer to EIA Standard, RS-198 (a Standard of Electronic Industries Association.)

3. The farad is the basic unit of capacitance, however capacitor values are generally expressed in terms of μfd (microfarad, .000001 farad) and $\mu\mu\text{f}$ (micro-micro-farad, .000001 μfd); therefore, 1,000 $\mu\mu\text{f}$ = .001 μfd , 1,000,000 $\mu\mu\text{f}$ = 1 μfd .

USING A PLASTIC NUT STARTER

A plastic nut starter offers a convenient method of starting the most used sizes: 3/16" and 1/4" (3-48 and 6-32). When the correct end is pushed down over a nut, the pliable tool conforms to the shape of the nut and the nut is gently held while it is being picked up and started on the screw. The tool should only be used to start the nut.

6-32

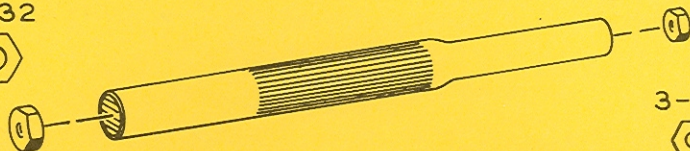

3-48



Assembly
and
Operation
of the



PORTABLE TRANSISTOR RADIO

MODEL GR-24



TABLE OF CONTENTS

Introduction.	2
Construction Notes.	2
Parts List.	3
Circuit Board Wiring And Soldering.	4
Step-By-Step Procedure.	5
Step-By-Step Assembly	
Circuit Board.	6
Tuning Capacitor.	9
Top Plate.	10
Dial Bracket.	11
Wiring.	12
Dial Cord Stringing.	12
Bezel.	15
Alignment.	18
Final Assembly.	19
Operation.	21
In Case Of Difficulty.	21
Troubleshooting Chart.	22
Point-To-Point Test.	23
Service Information	
Service.	24
Replacements.	25
Shipping Instructions.	25
Warranty.	26
Specifications.	26
Circuit Description.	27
Schematic. . . . (fold-out from page).	27

HEATH COMPANY,
BENTON HARBOR,
MICHIGAN

INTRODUCTION

The Model GR-24 Portable Transistor Radio uses a 6-transistor circuit to receive stations in the standard broadcast band. Parts are mounted on a printed circuit board for ease of assembly.

The ferrite rod antenna improves the reception

of weak stations. A push-pull output amplifier circuit and a large 4" x 6" speaker provide excellent tone quality. The slide rule dial allows you to select stations easily and accurately. Power is supplied by six 1-1/2 volt size "D" flashlight batteries.

CONSTRUCTION NOTES

This manual is supplied to assist you in every way to complete your kit with the least possible chance for error. The arrangement shown is the result of extensive experimentation and trial. If followed carefully, the result will be highly stable and dependable performance. We suggest that you retain the manual in your files for future reference, both in the use of the equipment and for its maintenance.

UNPACK THE KIT CAREFULLY AND CHECK EACH PART AGAINST THE PARTS LIST. In so doing, you will become acquainted with the parts. Refer to the information on the inside covers of the manual to help you identify the components. If some shortage or parts damage is found in checking the Parts List, please read the Replacements section and supply the information called for therein.

Resistors generally have a tolerance rating of 10% unless otherwise stated in the Parts List. Tolerances on capacitors are generally even greater. Limits of +100% and -20% are common for electrolytic capacitors.

We suggest that you do the following before work is started:

1. Lay out all parts so that they are readily available.
2. Provide yourself with good quality tools. Basic tool requirements consist of a screwdriver with a 1/4" blade; a small screwdriver with a 1/8" blade; long-nose pliers; wire cutters, preferably separate diagonal cutters; a penknife or a tool for stripping insulation from wires; and a soldering iron (or gun). A set of nut drivers, while not necessary, will aid extensively in construction of the kit.

Most kit builders find it helpful to separate the various parts into convenient categories. Muffin tins or molded egg cartons make convenient trays for small parts. Resistors and capacitors may be placed with their lead ends inserted in the edge of a piece of corrugated cardboard until they are needed. Values can be written on the cardboard next to each component. The illustration shows one method that may be used.

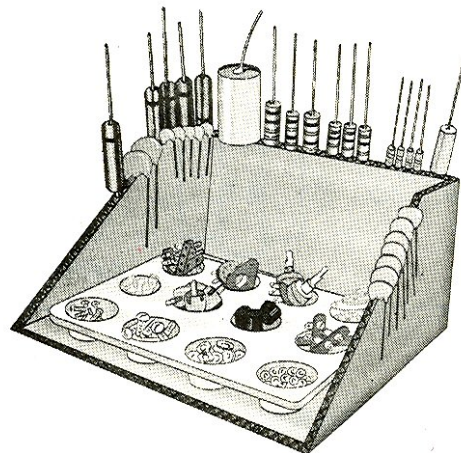



PARTS LIST

The numbers in parentheses in the Parts List are keyed to the numbers on the Parts Pictorial (fold-out from Page 5) to aid in parts identification.

PART No.	PARTS Per Kit	DESCRIPTION	PART No.	PARTS Per Kit	DESCRIPTION
RESISTORS 1/2 WATT			TRANSISTORS-DIODES		
(1) 1-129	2	4.7 Ω (yellow-violet-gold)	(12) 417-82	2	Transistor B846
1-3	1	100 Ω (brown-black-brown)	417-83	1	Transistor L842
1-45	1	220 Ω (red-red-brown)	417-84	1	Transistor E843
1-4	1	330 Ω (orange-orange-brown)	417-85	1	Transistor E844
1-6	1	470 Ω (yellow-violet-brown)	417-86	1	Transistor A845
1-9	2	1000 Ω (brown-black-red)	(13) 56-27	2	Silicon diode
1-11	1	1500 Ω (brown-green-red)	WIRE		
1-16	2	4700 Ω (yellow-violet-red)	344-15	1	Red stranded
1-19	2	6800 Ω (blue-gray-red)	344-16	1	Black stranded
1-73	1	8200 Ω (gray-red-red)	344-59	1	White hookup
1-25	1	47 K Ω (yellow-violet-orange)	HARDWARE		
1-33	1	470 K Ω (yellow-violet-yellow)	(14) 250-229	3	6-32 x 1/4" phillips head screw
1-142	1	560 K Ω (green-blue-yellow)	(15) 250-276	4	6-32 x 3/8" flat head screw (black)
CAPACITORS			(16) 250-9	7	6-32 x 3/8" round head screw
(2) 28-3	1	.56 μf phenolic (green-blue-gray)	(17) 250-18	4	8-32 x 3/8" round head screw
(3) 21-14	1	.001 μf disc	(18) 250-43	1	8-32 x 1/4" setscrew
21-47	3	.01 μf disc	(19) 252-2	4	4-40 nut (in envelope)
21-82	1	.02 μf disc	(20) 252-3	14	6-32 nut
(4) 21-48	2	.05 μf disc 50 V	(21) 252-39	2	1/4" control nut
(5) 21-94	4	.05 μf disc 10 V	(22) 252-82	8	Speednut (small)
(6) 25-149	3	5 μf electrolytic 15 V	(23) 252-10	4	Speednut (large)
25-117	3	100 μf electrolytic 12 V	(24) 254-9	4	#4 lockwasher (in envelope)
(7) 26-107	1	Tuning (3-section) 102, 235, and 235 μf	(25) 254-1	11	#6 lockwasher
COILS-TRANSFORMERS-CONTROL			(26) 254-2	2	#8 lockwasher
(8) 40-675	1	Rod antenna coil	(27) 254-14	2	1/4" control lockwasher
(9) 40-676	1	Oscillator coil	(28) 259-2	2	#8 solder lug
40-677	1	RF mixer coil	METAL PARTS		
52-89	1	IF interstage transformer	(29) 205-M484	1	Top plate
52-90	1	IF output transformer	(30) 204-M657	1	Reinforcing bracket
(10) 51-97	1	Audio driver transformer	(31) 100-M544P191-P192	1	Dial bracket assembly
51-98	1	Audio output transformer			
(11) 19-90	1	100 K Ω control (with off-on switch)			

PART No.	PARTS Per Kit	DESCRIPTION	PART No.	PARTS Per Kit	DESCRIPTION
GENERAL			MISCELLANEOUS		
93-9	1 ✓	Black case	(34) 100-M166	1	Dial pulley
85-121P190			100-M545	1	Dial cord
	1 ✓	Circuit board	463-41	1	Dial pointer
401-100	1 ✓	Speaker	(35) 453-134	1	Dial drive shaft
209-42	1 ✓	Speaker grille	(36) 258-1	1	Dial cord spring
(32) 210-27	1 ✓	Bezel	(37) 258-30	2	Battery contact spring
446-46	1	Plastic window	(38) 469-M12	1	Battery contactor
214-27	1	Battery housing	(39) 100-M433	1	Pulley bracket
(33) 214-28	2	Battery housing end	(40) 455-49	1	Bushing
391-35	1	Nameplate	462-211	2	Plastic knob
			(41) 207-22	2	Plastic clamp
			490-23	1	Allen wrench
			490-1	1	Alignment tool
			331-6		Solder
			595-745	1	Manual

NOTE: It will be necessary to purchase six size D flashlight batteries before the Radio can be put into operation.

CIRCUIT BOARD WIRING AND SOLDERING

Before attempting any work on the circuit board, read the following instructions carefully and study the Figures. It is necessary to observe the following basic precautions to insure proper operation of the unit.

Proper mounting of components on the board is essential for good performance. A good general rule to follow is that all components on the board should be mounted tightly to the board, unless instructions state otherwise. All leads should be kept as short as possible to minimize the effects of stray capacity in the wiring. Proper and improper methods of mounting are illustrated in the accompanying Figures.

NOTE: Exercise care not to damage resistors or capacitors when bending the leads as shown.

Tubular capacitors and resistors will fit properly if the leads are bent as shown. Disc capacitors will generally fit in place with no lead preparation other than determining that the leads are straight. Components with lugs normally require no preparation unless the lugs appear to be bent, in which case they can be straightened with pliers.

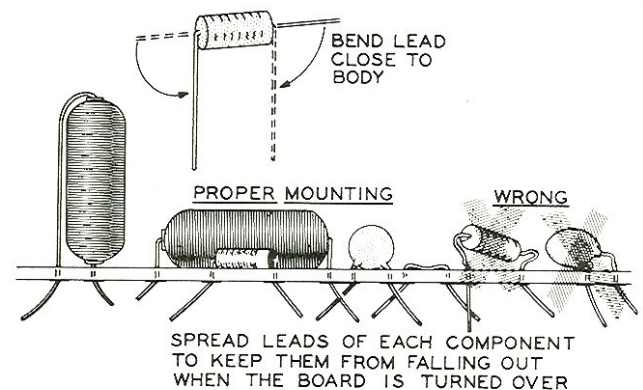

Parts should be inserted as instructed, and the leads bent outward, as illustrated, to lock them in place. When a group of parts have been installed on a circuit board, solder each lead to the foil pattern and clip off the excess wire.

The actual technique of soldering leads to a circuit board is quite simple. Position the tip of the soldering iron so that it firmly contacts both the circuit board foil and the wire or lug to be soldered, as shown. The iron should be

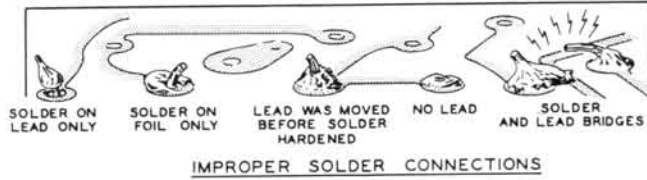
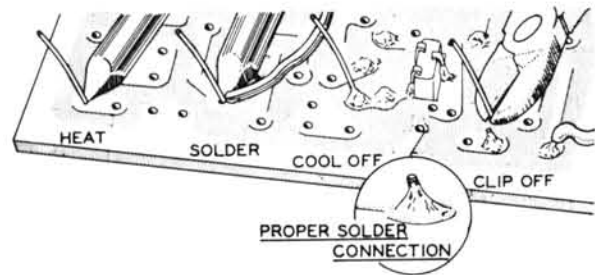

board damage due to overheating and excess solder.

The use of an excessive amount of solder will increase the possibility of bridging between foil conductors or plugging holes which are to be left open for wires which may be added later on. If solder is accidentally bridged across insulating areas between conductors, it can be cleaned off by heating the connection carefully and quickly wiping or brushing the solder away with a soft cloth or clean brush. Holes which become plugged can be cleared by heating the area immediately over the hole while gently pushing the lead of a resistor through the hole from the opposite side, and withdrawing the lead before the solder rehardens. Do not force the lead through; too much pressure before the solder has time to soften may separate the foil from the board.

held so that solder is not likely to flow to adjacent foil conductors or connections. The solder should immediately be placed between the iron and the joint to be soldered. Remove the length of solder as soon as its end begins to melt and flow onto the lead and foil. Hold the tip of the iron in place only until the solder begins to flow outward over the foil; then remove the iron quickly.

Avoid overheating the connection. A soldering pencil or small iron (approximately 25 watts) is ideal for use in circuit board work. If only a high wattage iron or soldering gun is available, precautions must be taken to avoid circuit

STEP-BY-STEP PROCEDURE

The following instructions are presented in a logical step-by-step sequence to enable you to complete your kit with the least possible confusion. Be sure to read each step all the way through before beginning the specified operation. Also read several steps ahead of the actual step being performed. This will familiarize you with the relationship of the subsequent operations. When the step is completed, check it off in the space provided. This is particularly important as it may prevent errors or omissions, especially if your work is interrupted. Some kit builders have also found it helpful to mark each wire and part in colored pencil on the Pictorial as it is added.

In general, the illustrations in this manual correspond to the actual configuration of the kit; however, in some instances the illustrations may be slightly distorted to facilitate clearly showing all of the parts.

SOLDERING

When a wire is installed, the terminal should be soldered and the abbreviation "S" is used to indicate this. Note that a number will appear after each solder instruction. This number indicates the number of leads that are supposed to be connected to the terminal in point before it is soldered. For example, if the instruction reads, "Connect a wire to lug 1 (S-2)," it will be understood that there will be two wires connected to the terminal at the time it is soldered.

ILLUSTRATIONS

The fold-out diagrams in this manual may be removed and attached to the wall above your working area; but because they are an integral part of the instructions, they should be returned to the manual after the kit is completed.

PARTS PICTORIAL

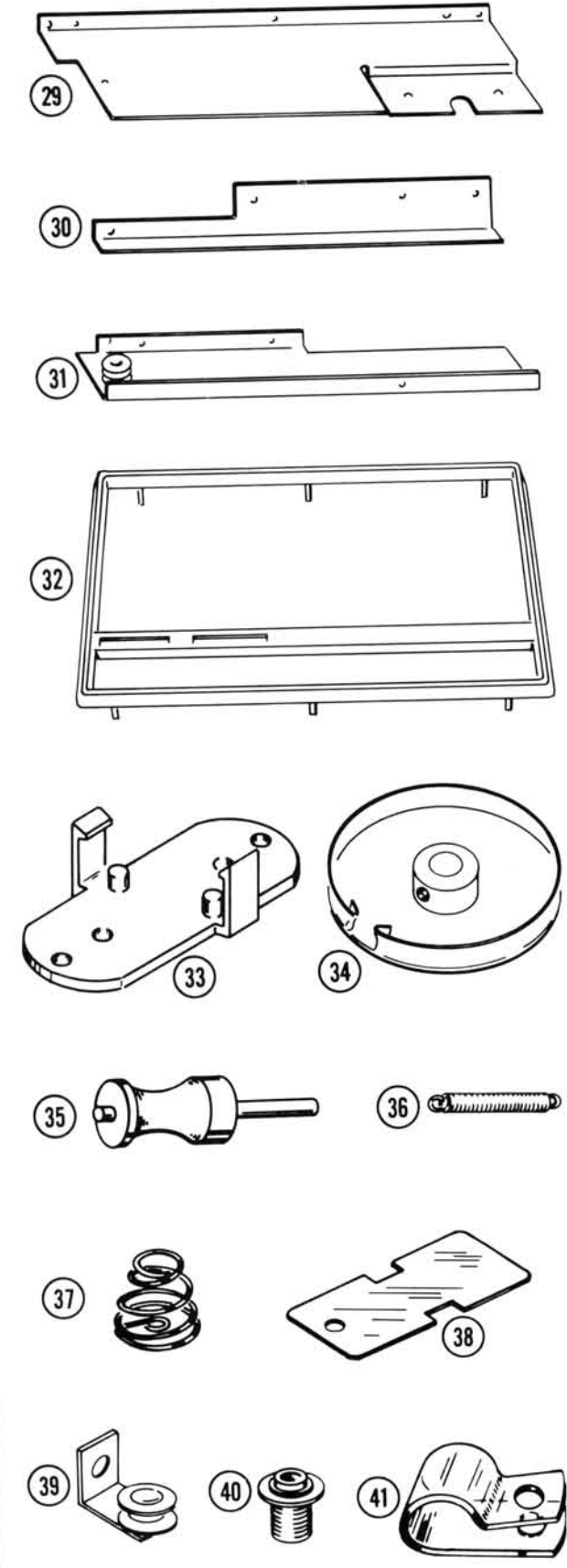
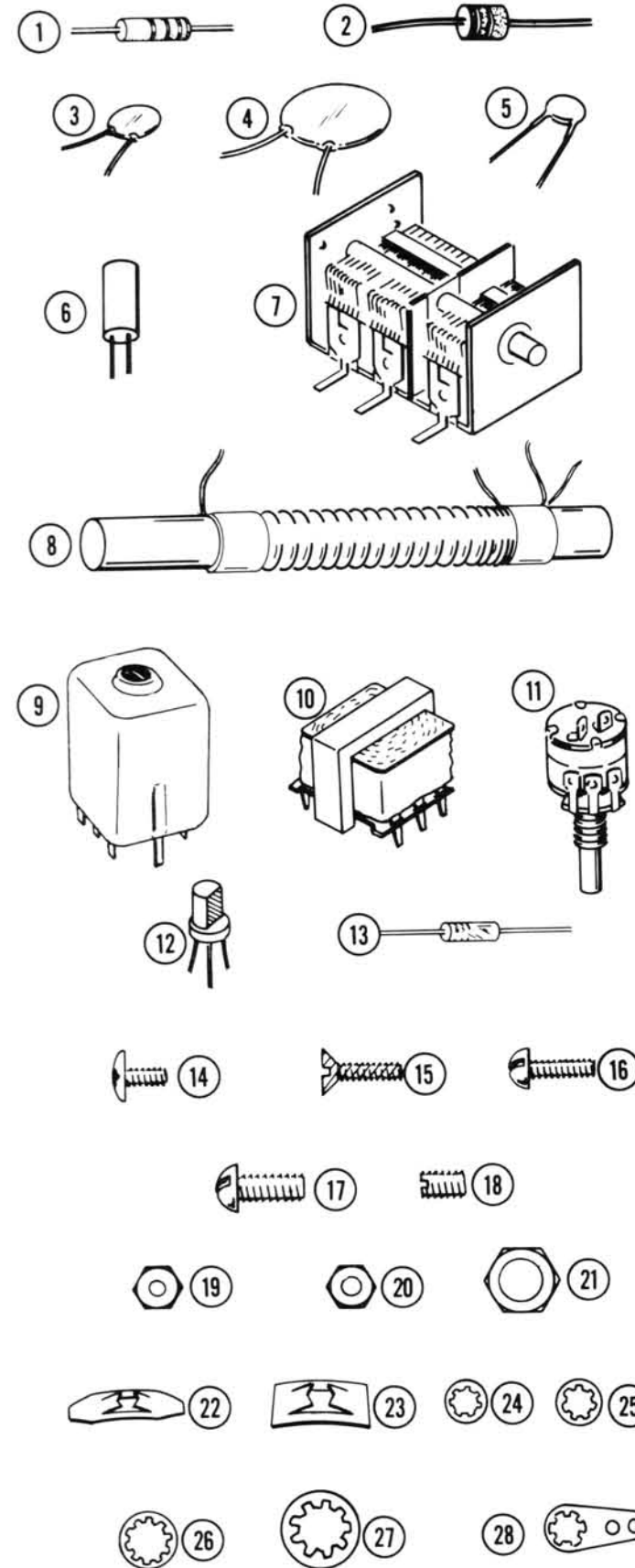

STEP-BY-STEP ASSEMBLY

CIRCUIT BOARD

Position the circuit board with the lettered side up, as shown in Pictorial 1.

Resistors are called out in the steps by their

value and color code. Capacitors are called out by their value and type.

After installing five to eight components, turn the circuit board over and solder all leads to the foil. After soldering, cut off each excess lead length close to the board.

START



CONTINUE



- (✓) 6800 Ω (blue-gray-red).
- (✓) 4700 Ω (yellow-violet-red).
- () .05 μfd disc (10 V).
- () .05 μfd disc (10 V).
- () .05 μfd disc (10 V).
- () 1000 Ω (brown-black-red).
- () 100 Ω (brown-black-brown).
- (✓) 100 μfd electrolytic. When installing electrolytic capacitors, be sure to position the positive (+) lead as shown.
- (✓) 4700 Ω (yellow-violet-red).
- (✓) 100 μfd electrolytic. Note + .
- () .02 μfd disc.
- () .05 μfd disc (50 V)
- () .01 μfd disc.
- () 4.7 Ω (yellow-violet-gold).
- () 6800 Ω (blue-gray-red).
- () 4.7 Ω (yellow-violet-gold).
- () Silicon diode. Position the banded end as shown.

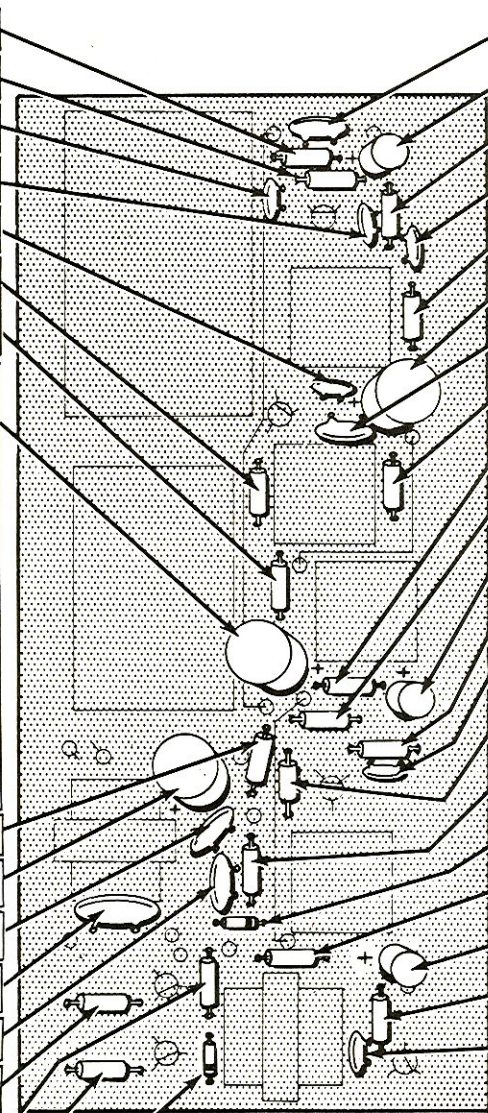
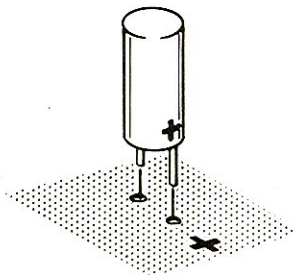

- () .01 μfd disc.
- () 5 μfd electrolytic. Note + .
- () 330 Ω (orange-orange-brown).
- () .05 μfd disc (50 V).
- () 560 KΩ (green-blue-yellow).
- () 100 μfd electrolytic. Note + .
- () .01 μfd disc.
- () 1500 Ω (brown-green-red).
- () 47 KΩ (yellow-violet-orange).
- () 8200 Ω (gray-red-red).
- () 5 μfd electrolytic. Note + .
- () 470 Ω (yellow-violet-brown).
- (✓) .05 μfd disc (10 V).
- () .56 μfd phenolic (green-blue-gray).
- () 1000 Ω (brown-black-red).
- () Silicon diode. Position the banded end as shown.
- () 220 Ω (red-red-brown).
- () 5 μfd electrolytic. Note + .
- () 470 KΩ (yellow-violet-yellow).
- () .001 μfd disc.

FINISH

PROCEED TO PICTORIAL 2

PICTORIAL 1

START ↓

NOTE: If desired, the following lengths of hookup wire may be pre-cut. Remove 1/4" of insulation from the ends of each wire. The wire lengths are listed in the order in which they will be used.
After installing each wire, turn the circuit board over and solder the wire to the foil. After soldering, cut off the excess lead length close to the board.

- () Prepare the following lengths of white hookup wire:
- | | |
|-----|--------|
| 10" | 2-1/4" |
| 10" | 2-1/2" |
| 3" | 2" |
| 3" | 2-3/4" |
| 5" | 2-3/4" |

- () Loosely twist together the two 10" wires.
() 10" twisted pair to SPKR.
() 3" wire to U.
() 3" wire to S.

- NOTE: Remove 1/4" of insulation from each end of a 6" black and a 6" red wire.
() 6" black wire to BATT -.
() 6" red wire to BATT +.

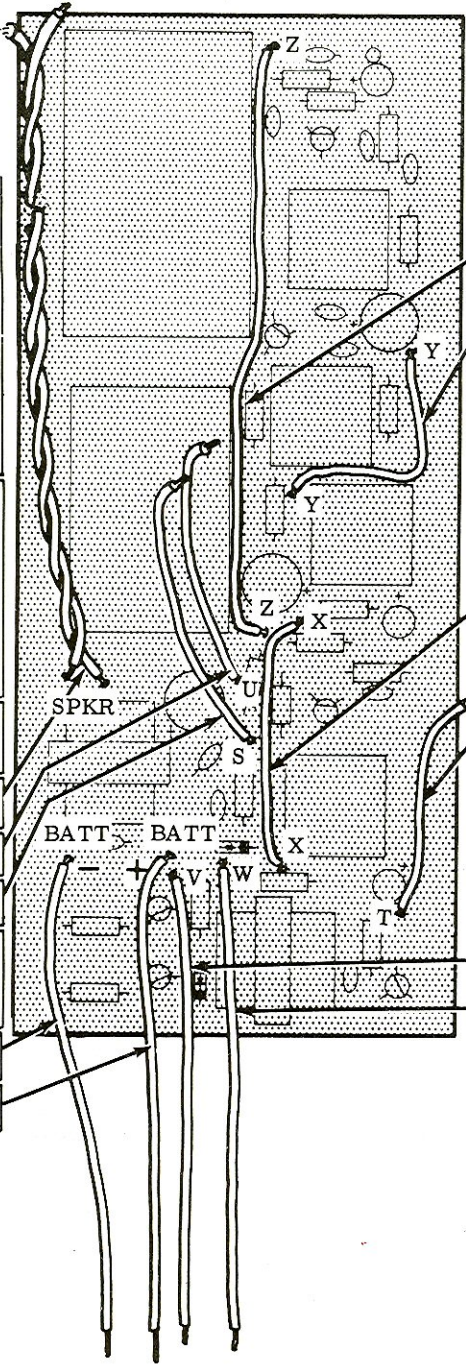

CONTINUE ↓

- () 5" wire between Z and Z.
() 2-1/4" wire between Y and Y.

- () 2-1/2" wire between X and X.
() 2" wire to T.

- () 2-3/4" wire to V.
() 2-3/4" wire to W.

FINISH
PROCEED TO PICTORIAL 3

PICTORIAL 2

START

NOTE: When installing transistors in the following steps, insert the transistor leads in their proper holes, as indicated by the letters E, C, and B. Position the transistors 1/4" away from the circuit board. Solder and clip off the excess lead lengths.

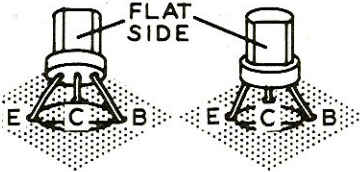

() Transistor L842.

() Transistor E843.

() Transistor E844.

() Transistor B846.

() Transistor B846.

() Transistor A845.

NOTE: After installing each transformer and coil, turn the circuit board over and solder each lug to the foil. It is not necessary to clip off the excess length.

() Output transformer (#51-98).

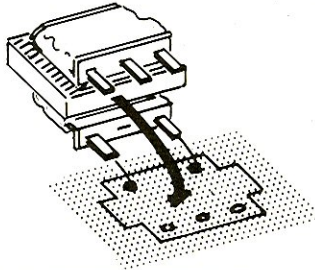

() Audio driver transformer (#51-97).

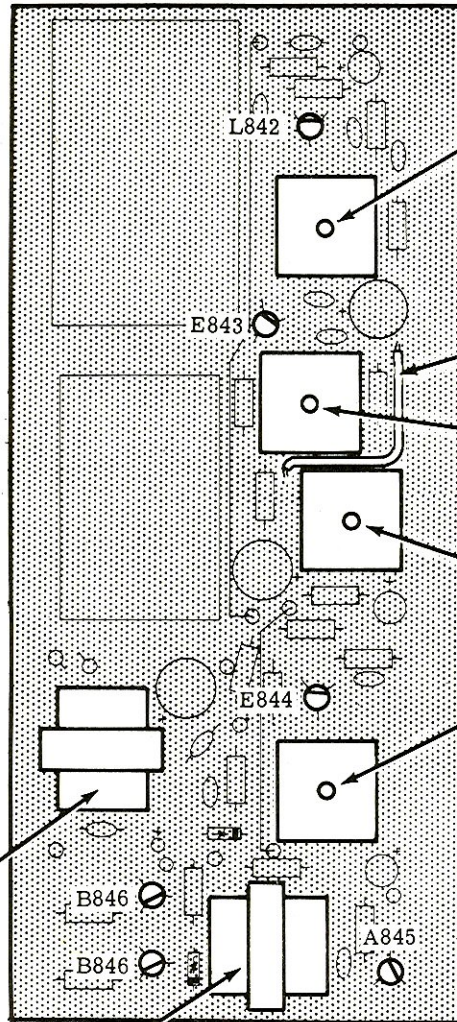

CONTINUE

() RF mixer coil (#40-677).

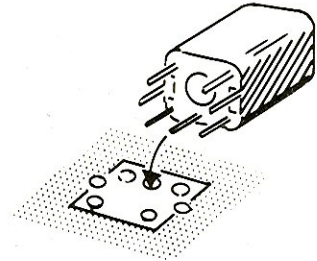

NOTE: In the next two steps, be careful not to pinch this wire between the transformer and the circuit board.

() Oscillator coil (#40-676).

() Locate the IF interstage transformer (#52-89). Note that the three lugs on one side of the transformer are more closely spaced than the three lugs on the opposite side. Observe the hole spacing on the circuit board, and then install the transformer.

() IF output transformer (#52-90).

Carefully inspect the foil side of the circuit board and solder any connections that might have been missed. Also, check for accidental solder bridges between foils.

FINISH

PROCEED TO PICTORIAL 4

PICTORIAL 3

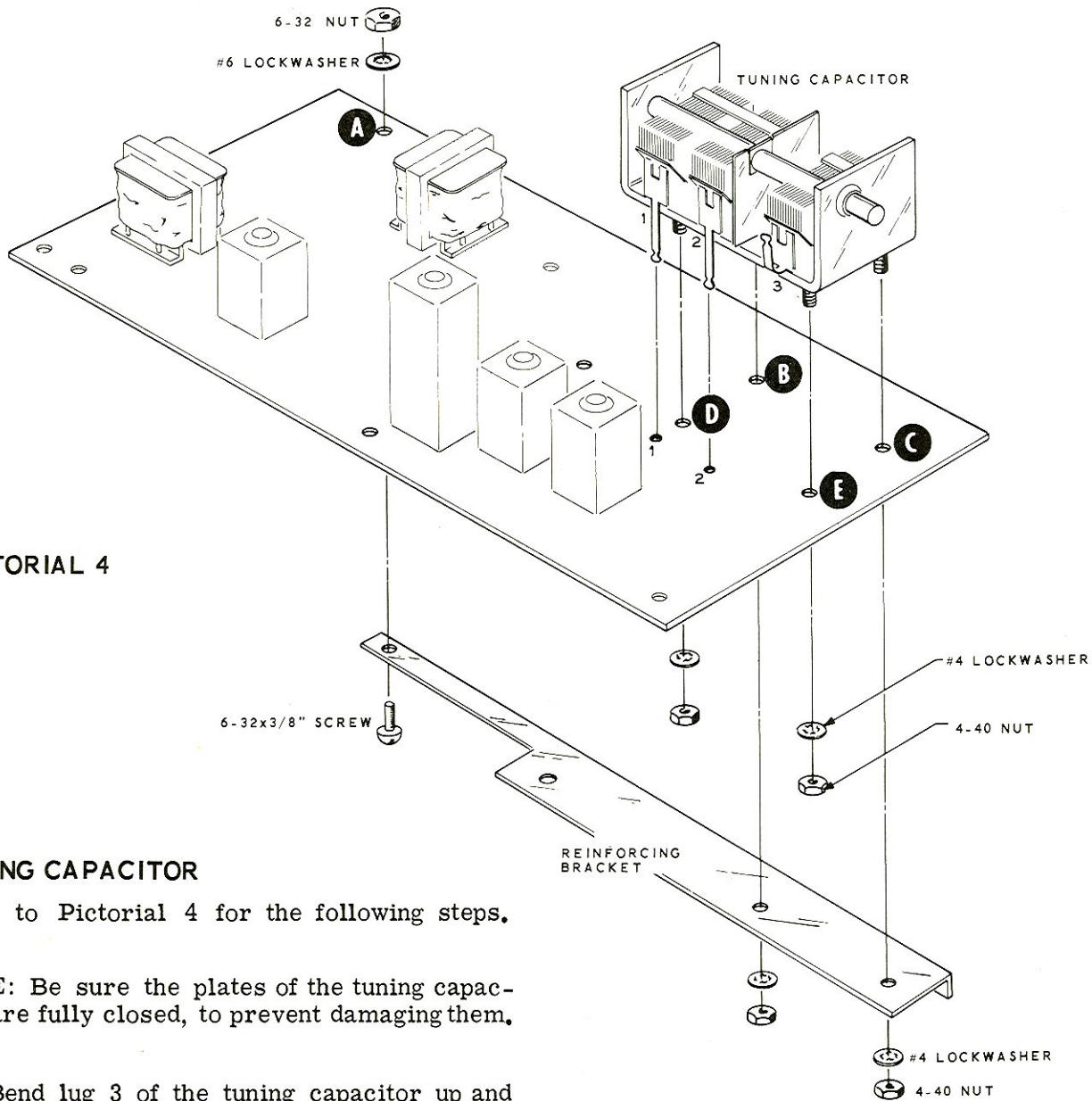

PICTORIAL 4

TUNING CAPACITOR

Refer to Pictorial 4 for the following steps.

NOTE: Be sure the plates of the tuning capacitor are fully closed, to prevent damaging them.

- () Bend lug 3 of the tuning capacitor up and lugs 1 and 2 down as shown in the Pictorial.
- () Mount the tuning capacitor on the circuit board. Use a 4-40 nut and #4 lockwasher at holes D and E. Be sure to position lugs 1 and 2 of the capacitor through holes 1 and 2 of the circuit board. Also make sure the white hookup wire, installed on the circuit board, is not positioned under the capacitor.
- () Turn the circuit board over and solder lugs 1 and 2 to the foil. Clip off the excess lead length.

NOTE: Where the term "6-32 hardware" is called out in a step, use a 6-32 x 3/8" round head screw, a #6 lockwasher, and a 6-32 nut.

- () Mount the reinforcing bracket on the circuit board, using 6-32 hardware at hole A.
- () Secure the other end of the bracket to the tuning capacitor. Use 4-40 nuts and #4 lockwashers at holes B and C.

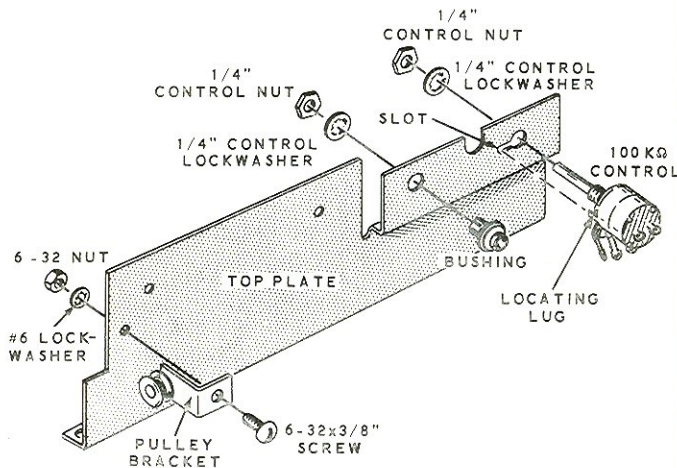

PICTORIAL 5

TOP PLATE

Refer to Pictorial 5 for the following steps.

- () Mount the pulley bracket on the top plate. Use 6-32 hardware.
- () Mount the bushing on the top plate. Use a 1/4" control lockwasher and 1/4" control nut.
- () Mount the 100 K Ω control on the top plate. Use a 1/4" control lockwasher and a 1/4" control nut. Position the control so that the locating lug lines up with the slot as shown.

Refer to Pictorial 6 for the following steps.

- () Mount the top plate to the circuit board. Use 6-32 hardware at F. Do not tighten the screw at this time.

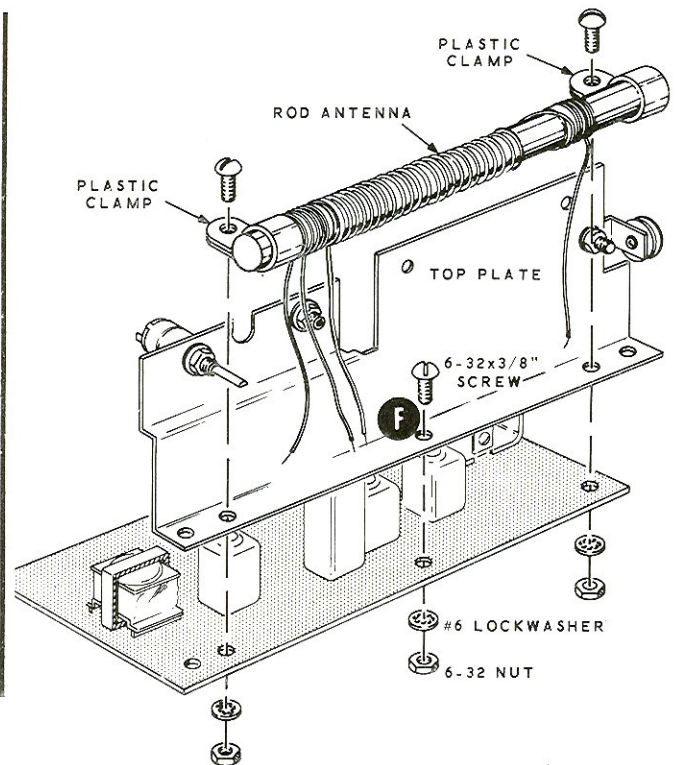

PICTORIAL 6

- () Locate the rod antenna and two plastic clamps. Install a plastic clamp on each end of the rod antenna. Make sure the end of the antenna with the three wires, is positioned as shown.
- () Mount the rod antenna on the top plate with 6-32 hardware. Before tightening the screws, rotate the antenna in the clamps so the wires are pointed toward the circuit board.

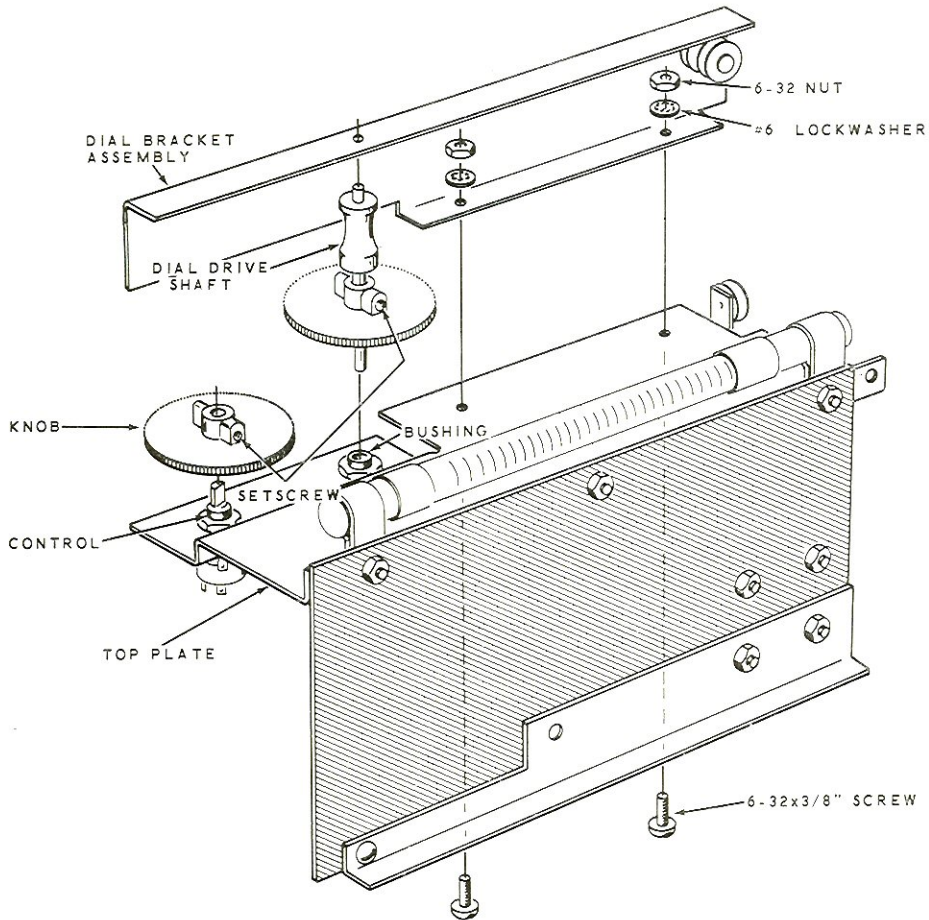

PICTORIAL 7

DIAL BRACKET

Refer to Pictorial 7 for the following steps.

- () Install either black knob on the control shaft. Do not tighten the setscrew in the knob.
- () Install the remaining black knob on the long end of the dial drive shaft. Tighten the setscrew with the Allen wrench, against

the flat side of the shaft. Now loosen the setscrew slightly so the knob can slide freely on the flat portion of the shaft. Insert the drive shaft into the bushing mounted to the top plate.

- () Fasten the dial bracket assembly to the top plate. Use 6-32 hardware. Do not tighten the screws. They will be left loose until the dial stringing has been completed later.

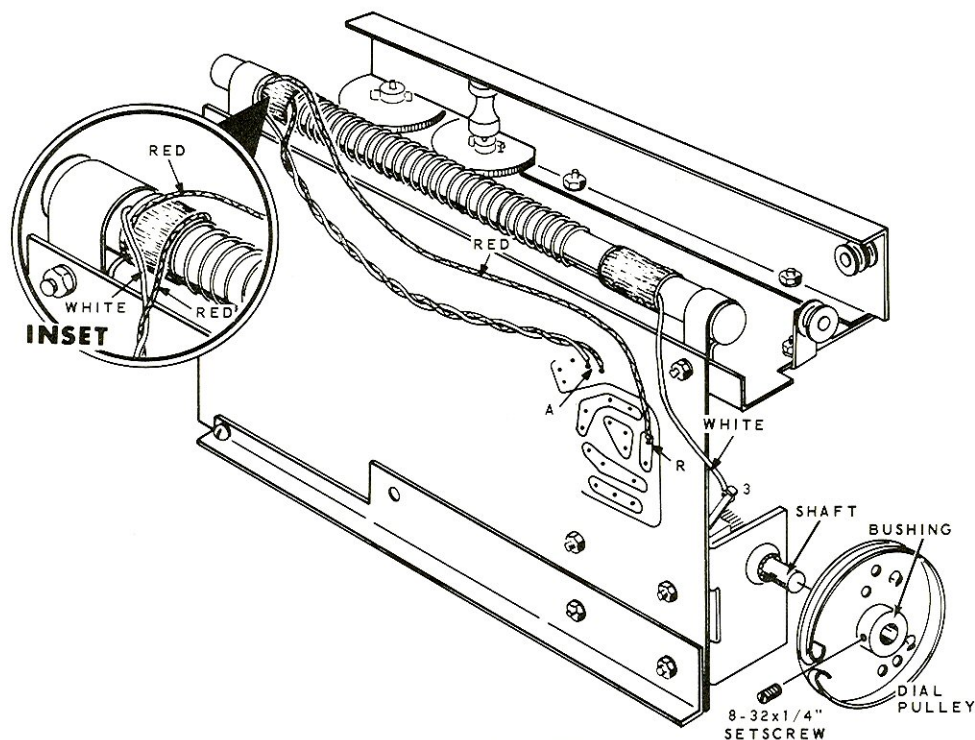

PICTORIAL 8

WIRING

Refer to Pictorial 8 for the following steps.

- () Referring to the inset drawing on Pictorial 8, loosely twist together the indicated red and white antenna leads.
- () Connect either twisted lead to one of the holes at point A on the circuit board (S-1). Connect the remaining lead to the other hole at A (S-1).
- () Connect the remaining red lead to point R on the circuit board (S-1).
- () Connect the white lead coming from the other end of the antenna to lug 3 of the tuning capacitor (S-1). Position this lead as shown.
- () Start an 8-32 x 1/4" setscrew into the dial pulley bushing.

- () Be sure the plates of the tuning capacitor are fully closed. Then mount the dial pulley on the tuning capacitor shaft with the dial pulley bushing flush with the end of the capacitor shaft. Position the opening in the pulley toward the circuit board and tighten the setscrew.

DIAL CORD STRINGING

Refer to Pictorial 9 for the following steps.

- () Locate the dial cord and dial spring.
- () Referring to inset drawing #1 on Pictorial 9, carefully bend both ends of the spring to form a small hook. Set the spring aside temporarily.
- () Rotate the dial pulley clockwise until the plates of the tuning capacitor are fully closed.

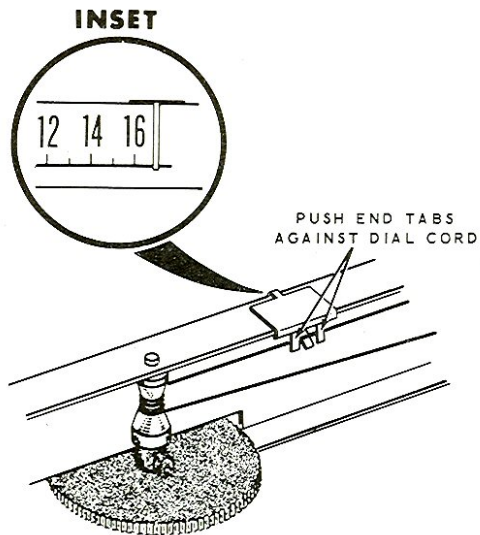

Detail 9C

Refer to Detail 9C for the following steps.

- () Rotate the dial drum counterclockwise until the plates of the tuning capacitor are fully open. Be careful not to accidentally bend the capacitor plates while performing the following steps.
- () With the tuning capacitor plates still open, slide the dial pointer to the last mark on the right side of the dial as shown in the inset drawing on Detail 9C.
- () With the pointer held tightly in this position, place the dial cord between the tabs as shown. Now using a screwdriver, carefully push both end tabs against the dial cord.

Refer to Pictorial 10 for the following steps.

NOTE: Connect the following wires from the circuit board to the control.

- () Connect the wire from point U to lug 1 on the control (S-1).

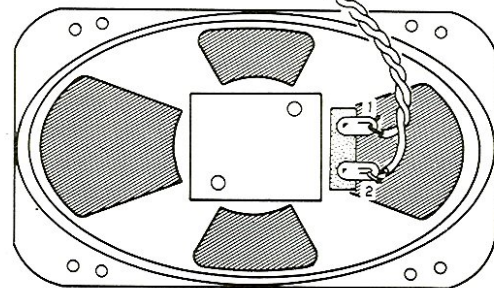
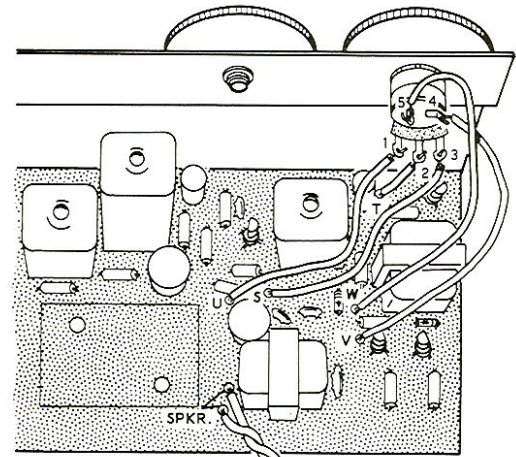

PICTORIAL 10

- () Connect the wire from point T to lug 2 on the control (S-1).
- () Connect the wire from point S to lug 3 on the control (S-1).
- () Connect the wire from point V to lug 4 on the control (S-1).
- () Connect the wire from point W to lug 5 on the control (S-1).
- () Position the speaker near the circuit board as shown.
- () Connect either lead of the twisted pair coming from the circuit board to lug 1 of the speaker (S-1). Connect the remaining lead to lug 2 (S-1).

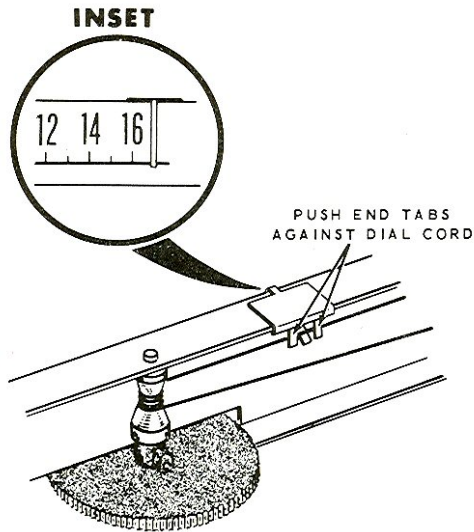

Detail 9C

Refer to Detail 9C for the following steps.

- () Rotate the dial drum counterclockwise until the plates of the tuning capacitor are fully open. Be careful not to accidentally bend the capacitor plates while performing the following steps.
- () With the tuning capacitor plates still open, slide the dial pointer to the last mark on the right side of the dial as shown in the inset drawing on Detail 9C.
- () With the pointer held tightly in this position, place the dial cord between the tabs as shown. Now using a screwdriver, carefully push both end tabs against the dial cord.

Refer to Pictorial 10 for the following steps.

NOTE: Connect the following wires from the circuit board to the control,

- () Connect the wire from point U to lug 1 on the control (S-1).

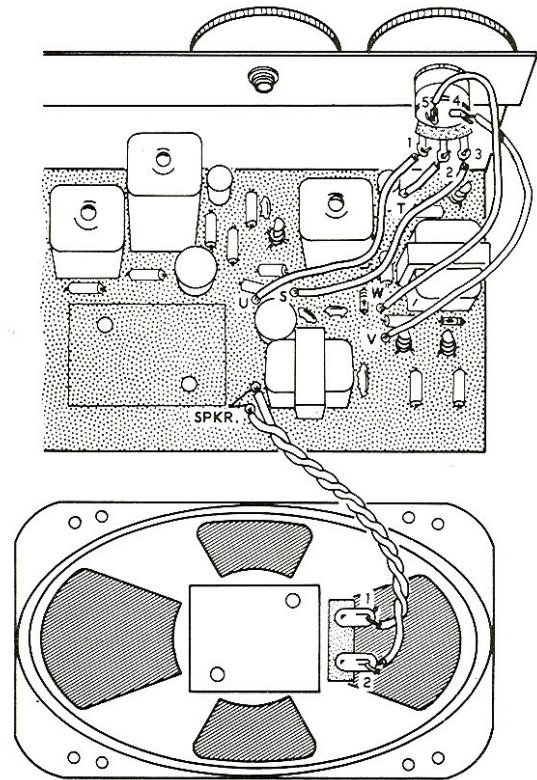

PICTORIAL 10

- () Connect the wire from point T to lug 2 on the control (S-1).
- () Connect the wire from point S to lug 3 on the control (S-1).
- () Connect the wire from point V to lug 4 on the control (S-1).
- () Connect the wire from point W to lug 5 on the control (S-1).
- () Position the speaker near the circuit board as shown.
- () Connect either lead of the twisted pair coming from the circuit board to lug 1 of the speaker (S-1). Connect the remaining lead to lug 2 (S-1).

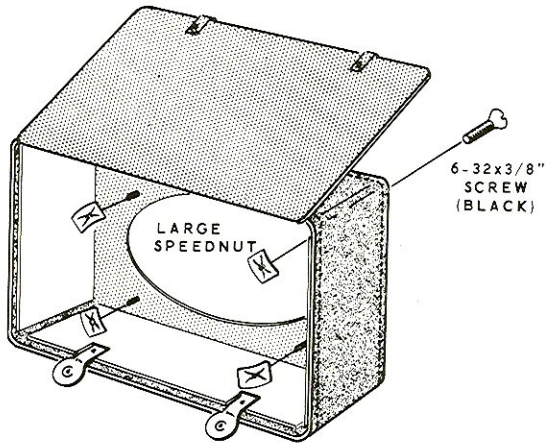

PICTORIAL 11

BEZEL

- () Referring to Pictorial 11, install four 6-32 x 3/8" flat head screws (black) to the case, using the large speednuts.
- (✓) Locate the bezel, plastic window, and grille.
- () Referring to Detail 12A, remove the protective backing and then press the nameplate into position on the front of the bezel.
- () Remove the protective backing from both sides of the plastic window.

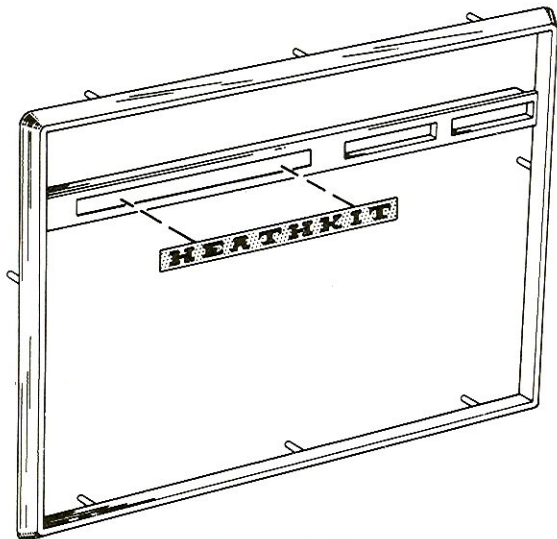

Detail 12A

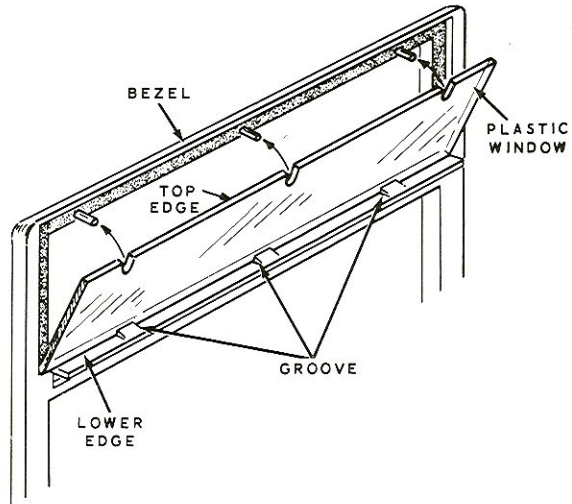

Detail 12B

- () Referring to Detail 12B, install the plastic window in the bezel by placing the lower edge of the window in the bezel grooves. Now push the top edge of the window into place in the bezel.

Refer to Pictorial 12 for the following steps.

- (✓) Install the grille on the bezel by placing it in the large opening in the lower half of the bezel.

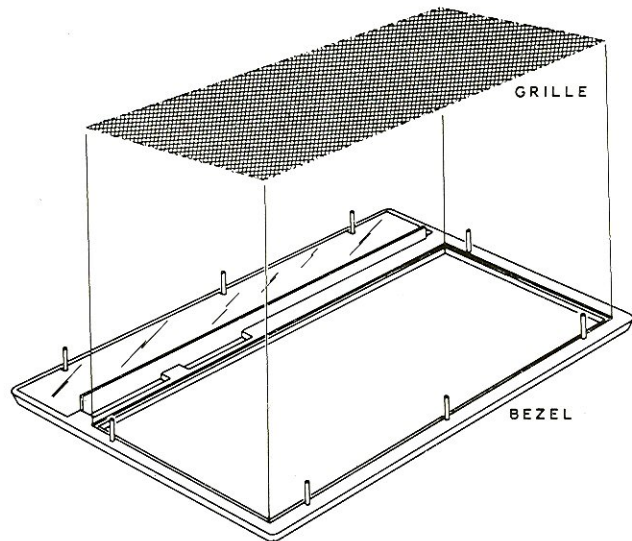

PICTORIAL 12

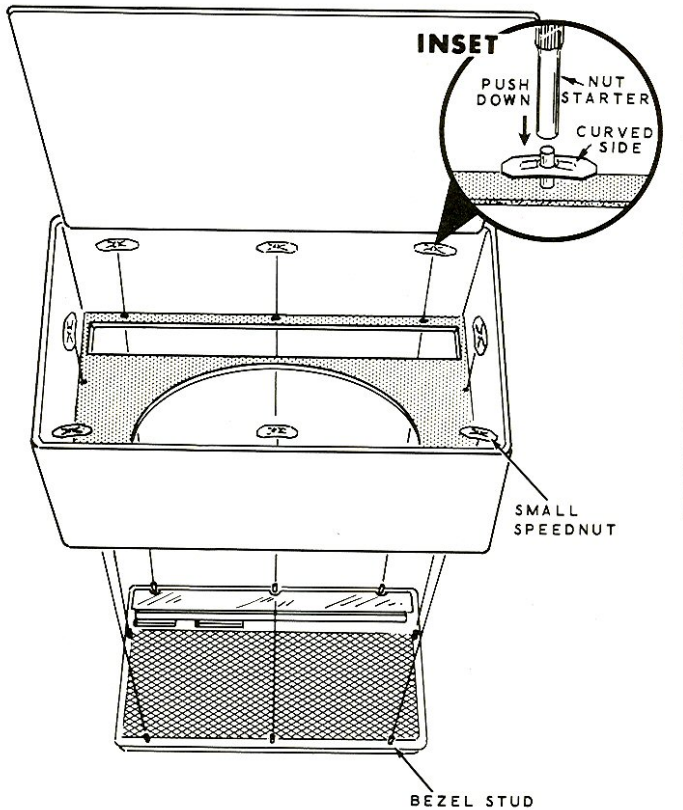

PICTORIAL 13

Refer to Pictorial 13 for the following steps.

- () Place the bezel on your working area with the studs facing up. Mount the case on the bezel by positioning the studs into the holes in the front of the case.
- () Push one of the eight small speednuts firmly onto each of the studs inside the case. One method of doing this is to use the nut starter as shown in the inset drawing on Pictorial 13.

Refer to Detail 14A for the following steps.

- () Locate both battery holder ends, both battery springs, and the battery contactor.
- () Install a 6-32 x 1/4" phillips head screw, a #8 solder lug, and a 6-32 nut at plus (+) on either battery holder end.

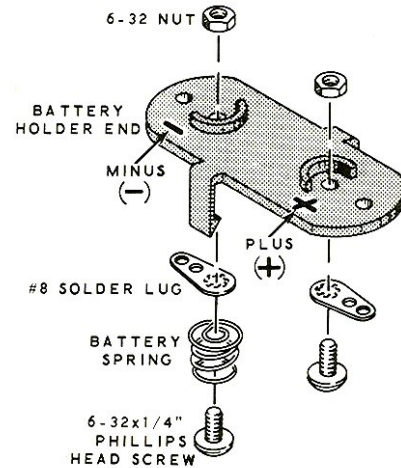

Detail 14A

- () Mount a battery spring in the hole at minus (-). Use a 6-32 x 1/4" phillips head screw, a #8 solder lug, and a 6-32 nut.

Refer to Detail 14B for the following steps.

- () Position the red wire, coming from the circuit board, through hole A to the plus (+) solder lug (S-1). Clip off the excess wire close to the solder lug.
- () Position the black wire, coming from the circuit board, through hole B to the minus (-) solder lug (S-1). Clip off the excess wire close to the solder lug.

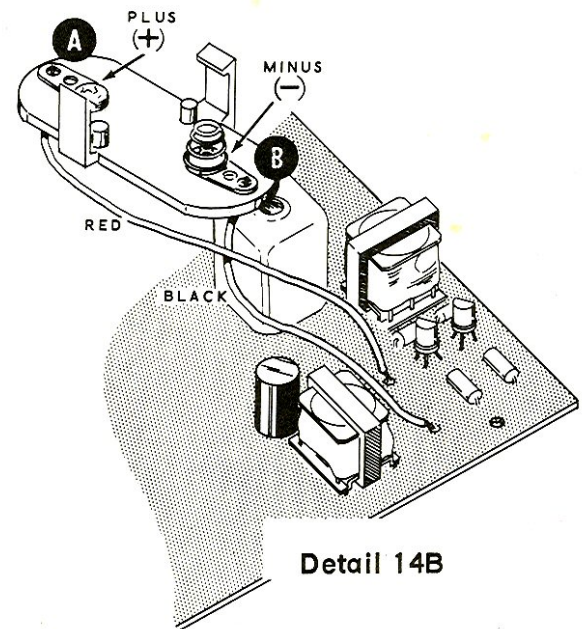

Detail 14B

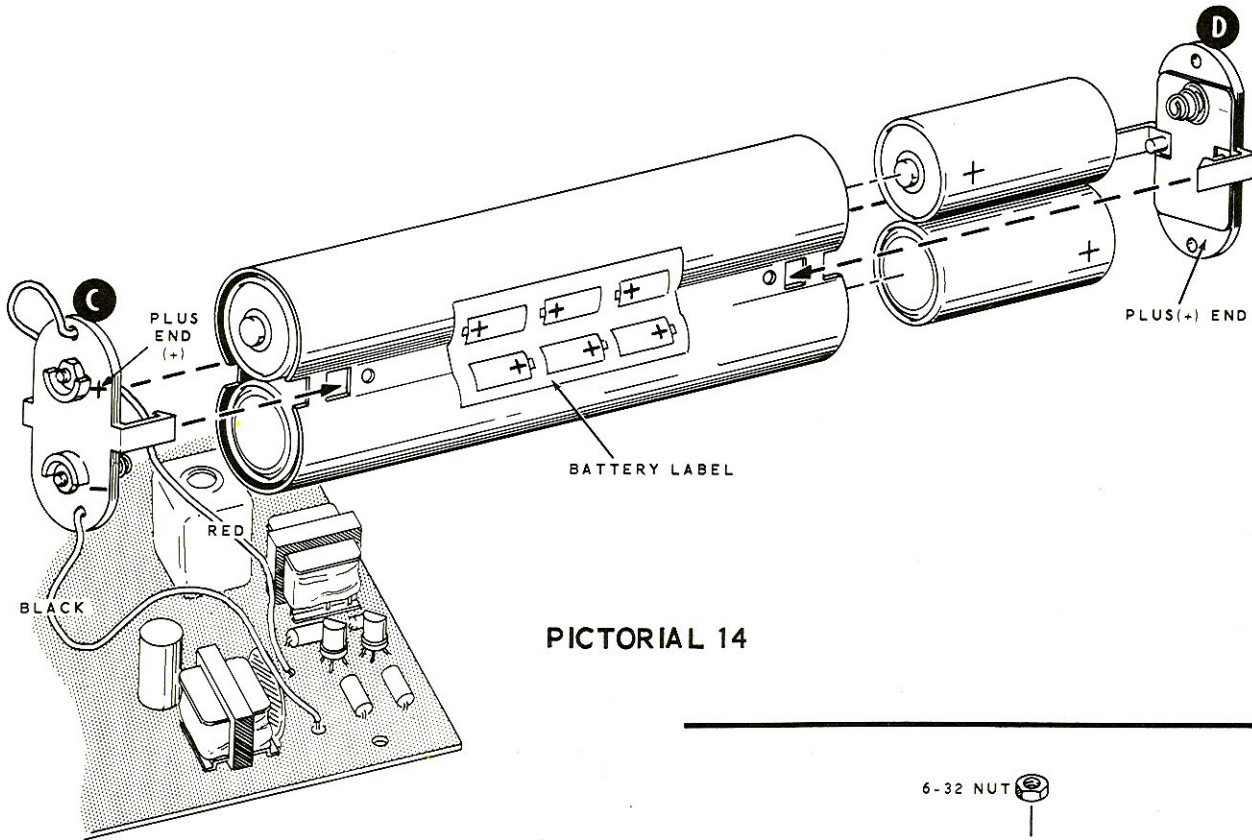

PICTORIAL 14

- () Referring to Detail 14C, mount the battery contactor and spring on the remaining battery holder end. Use a 6-32 x 1/4" phillips head screw, and a 6-32 nut in the hole at minus (-).

Refer to Pictorial 14 for the following steps.

- () Locate the battery holder and battery label.
- () Remove the paper backing from the battery label. Stick the label on the side of the battery holder as shown.
- () Push battery end D (the one with battery contactor) onto either end of the battery holder until it snaps into place. Position the plus (+) end as shown.
- () Install the six batteries in the battery holder. Position the positive (+) ends of the batteries as shown on the battery label.

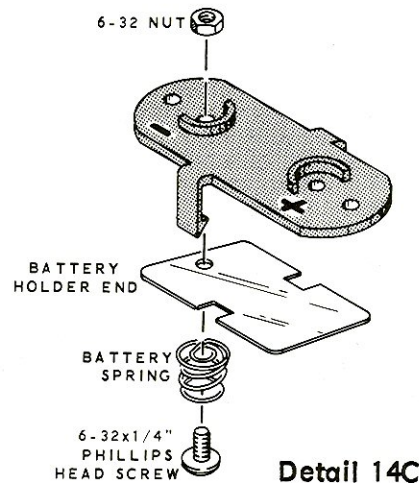

Detail 14C

- () Install battery end C on the battery holder; position the plus (+) end as shown.

This completes the electrical assembly of the Radio. Carefully inspect the circuit board for any loose or unsoldered connections. Turn the circuit board over and shake out any loose bits of solder or wire that may be lodged in the components.

ALIGNMENT

Turn on the Radio with the Volume control, then turn this control until you hear a rushing or hissing sound. If this sound is heard, proceed with the alignment steps. If no sound is heard, turn off the Radio and refer to the In Case Of Difficulty section.

Read each of the following steps completely before performing the adjustment.

Refer to Figure 1 (fold-out from Page 27) for the following steps.

STEP ONE

- A. Turn tuning capacitor adjusting screws, C1, C6 and C12 down snugly in a clockwise direction without forcing them.
- B. Loosen the antenna trimmer screw, C1, 1/8 turn.
- C. Loosen the RF trimmer screw, C6, 1/2 turn.
- D. Loosen the oscillator trimmer screw, C12, 1/4 turn.

STEP TWO

This procedure will adjust the IF amplifier for maximum gain.

- A. Tune in a weak station near the low frequency end of the dial (6 to 8 on the dial).
- B. Using the alignment tool provided, carefully turn the internal adjustment of transformer T2 left or right to obtain maximum volume.

NOTE: Transformer T1, which will be adjusted next, has two internal adjustments; top and bottom. To reach the bottom adjustment, push the alignment tool through the hole in the top adjustment as shown in Figure 2.

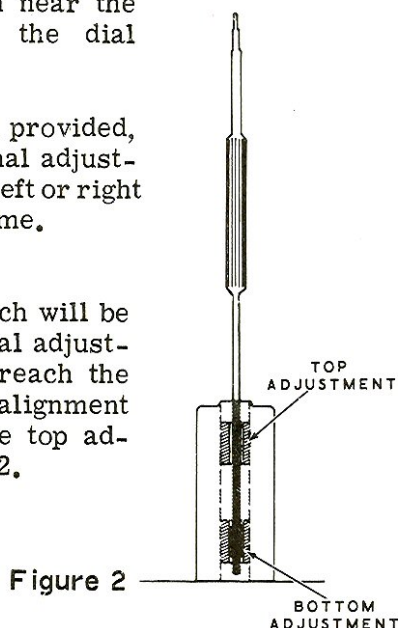

Figure 2

- C. Turn the bottom adjustment of transformer T1 left or right for maximum volume. Repeat this procedure with the top adjustment.
- D. Repeat adjustments B and C. The reason for repeating B and C is because of the interaction between transformers T1 and T2.

STEP THREE

This procedure will adjust the oscillator circuit so the station received is indicated correctly on the dial.

- A. Tune to a known local station at the high end of the dial (14 to 16). Refer to the station listings in your local newspaper to learn the frequency of this station.
- B. Turn the dial pointer to the correct dial number for this station. Adjust screw C12, on the variable capacitor, slightly to the left or right to tune in the correct station, and to obtain maximum volume.

STEP FOUR

This procedure will adjust the antenna and RF circuits to provide maximum sensitivity at the high frequency end of the dial.

- A. Tune in a weak station at the high frequency end of the dial (14 to 16 on the dial).
- B. Adjust screw C1 on the variable capacitor to obtain maximum volume.
- C. Adjust screw C6 on the variable capacitor to obtain maximum volume.

STEP FIVE

This procedure will adjust the oscillator circuit at the low frequency end of the dial.

- A. Turn on a source of electrical "noise" such as a fluorescent lamp, electric shaver, or an electric mixer.
- B. Place the Radio near the noise source so that static will be heard. Turn the Tuning knob so the dial pointer is near the low frequency end of the dial (6 on the dial). Do not tune to a station.
- C. Adjust oscillator coil L3 to obtain maximum noise volume. If a station is heard during this adjustment, turn the Tuning knob a small amount until only the noise is heard.

STEP SIX

This procedure will adjust the RF circuit for maximum sensitivity at the low frequency end of the dial.

- A. Tune in a weak station at the low frequency end of the dial (6 on the dial).
- B. Adjust coil L2 to obtain maximum volume.

STEP SEVEN

Because the adjustments tend to interact slightly, repeat steps 3, 4, 5, and 6 to obtain best results.

NOTE: This alignment procedure will provide optimum Radio performance. Alignment with instruments would not provide any expected improvement in performance.

FINAL ASSEMBLY

- () Refer to Pictorial 15. With the leads coming from the left side, fasten the speaker to the four screws inside the cabinet. Use #6 lockwashers and 6-32 nuts. Do not tighten the nuts at this time.

NOTE: In the following steps the Radio will be temporarily installed in the case. This will enable you to more easily center the knobs in this case slots. Be sure to close the plates of the tuning capacitor to avoid damaging them.

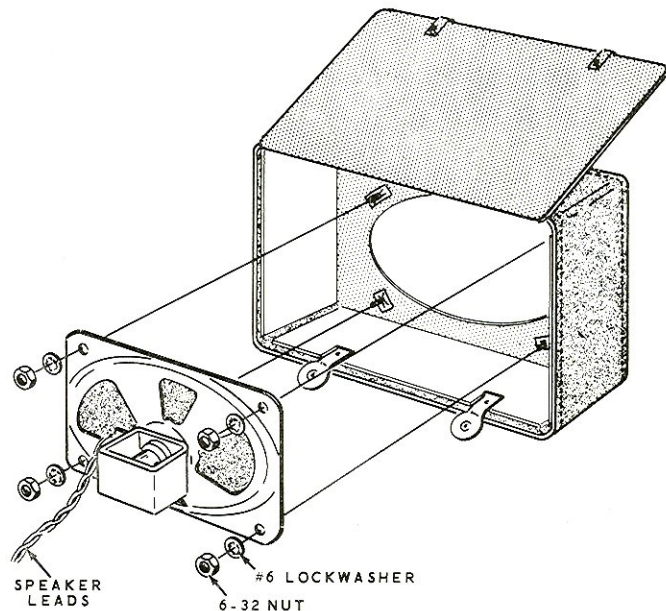
PICTORIAL 15

Refer to Pictorial 16 for the following steps.

- () Before installing the Radio into the case, note that the edge of the top plate must be positioned in the dial window opening as shown in Detail 16A.
- () Install the Radio in the case; position the dial assembly underneath the two brackets mounted on the sides of the case.
- () Secure both corners of the circuit board to the case. Use 8-32 x 3/8" screws at A and B.
- () Fasten the middle of the circuit board to the speaker with 8-32 x 3/8" screws and #8 lockwashers at C and D. It may be necessary to move the speaker slightly to line up the holes.
- () Tighten the speaker nuts at E and F.
- () Remove the screws at A, B, C, and D and remove the Radio from the case.
- () Tighten the two remaining speaker nuts. Install the Radio in the case. Make sure no wires are pinched between the speaker and circuit board.
- () Reinstall the 8-32 screws at A and B.
- () Reinstall the 8-32 screws and #8 lockwashers at C and D.
- () Install the battery housing in the case.

NOTE: The blue and white identification label shows the Model Number and Production Series Number of your kit. Refer to these numbers in any communications with the Heath Company; this assures you that you will receive the most complete and up-to-date information in return.

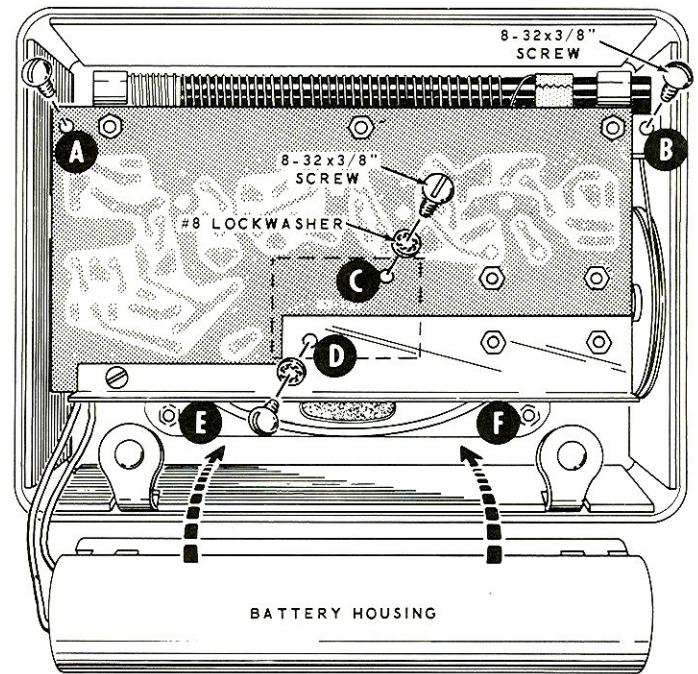

PICTORIAL 16

- () Install the identification label in the following manner:
 1. Select a location for the label where it can easily be seen when needed, but will not show when the unit is in operation. This location might be on the rear panel or the top of the chassis, or on the rear or bottom of the cabinet.
 2. Carefully peel away the backing paper. Then press the label into position.

This completes the assembly of the Radio. Close the back of the case. The Radio is ready to be put into use.

Detail 16A

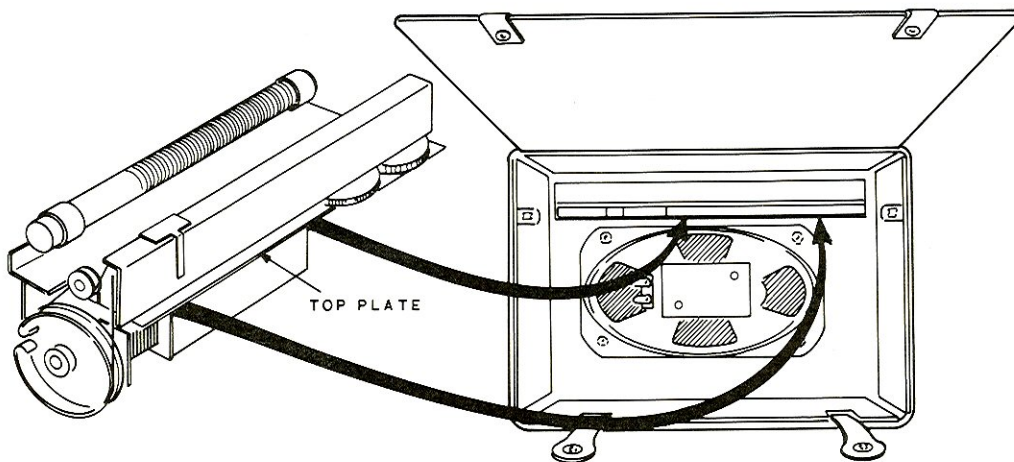

OPERATION

Operation is simple and conventional. Turn on the Radio, select the desired station and adjust the volume.

Because the rod antenna is directional, maximum volume will occur when the front or back of the Radio faces toward the station.

Reception in automobiles, trains, and airplanes is possible in most locations, although it may be necessary to place the Radio near a window for best results. Otherwise, the metal body of the vehicle may act as a shield against the radio signals.

You will probably notice some distortion of the sound at maximum volume. This is normal and

represents the reserve of power that provides good reception even when the battery is run down considerably. Signs of a weak battery are low volume, excessive distortion, and failure to operate at some section of the dial.

Always remove worn-out batteries immediately. The old batteries may swell and make removal difficult, or may leak chemical compounds that would cause corrosion. Do not store the radio for extended periods without removing the batteries.

NOTE: The cabinet should withstand all normal handling. It may be cleaned with a damp cloth and mild soap when necessary. DO NOT use solvents, cleaning fluids or abrasives to clean the cabinet.

IN CASE OF DIFFICULTY

1. Recheck the wiring. It is frequently helpful to have a friend check your work. Someone who is not familiar with the unit may notice something consistently overlooked by the constructor.
2. It is interesting to note that about 90% of the kits that are returned for repair do not function properly due to poor connections and soldering. Therefore, many troubles can be eliminated by reheating all connections to make sure that they are soldered as described in the Circuit Board Wiring And Soldering section.
3. Check the values of the parts. Be sure that the proper part has been wired into the circuit, as shown in the pictorial diagrams and as called out in the wiring instructions.
4. Check for bits of solder, wire ends or other foreign matter which may be lodged in the wiring.
5. If, after careful checks, the trouble is still not located and a voltmeter is available, check voltage readings against those shown on the Schematic Diagram. NOTE: All

voltage readings were taken with an 11 megohm input vacuum tube voltmeter. Voltages may vary as much as 10%.

6. A review of the Circuit Description will prove helpful in indicating where to look for trouble.
7. An X-ray view of the circuit board is located on a fold-out with the Schematic Diagram (Page 27). This X-ray view with the Schematic, can be used for circuit tracing. The circuit board is viewed from the foil side.
8. The following chart lists EIA equivalent transistors for the GR-24 Radio.

GR-24 TYPE	EIA EQUIVALENT TRANSISTORS
B846	2N2714
L842	2N2715
E843	2N2716 (Beta less than 150)
E844	2N2716 (Beta greater than 150)
A845	2N2926

TROUBLESHOOTING CHART

DIFFICULTY	POSSIBLE CAUSE
Radio completely dead.	<ol style="list-style-type: none"> 1. Batteries installed wrong. 2. Faulty batteries. 3. Faulty off-on switch. 4. Transistors installed wrong. 5. Faulty transistor Q4, Q5, or Q6. 6. Faulty transformer T3, or T4. 7. NOTE: Refer to Point-To-Point Test.
Hiss in speaker but no stations received.	<ol style="list-style-type: none"> 1. Improper alignment. 2. Faulty diode D1. 3. Faulty transistor Q1, Q2, or Q3. 4. Open capacitor C3, C10, or C20. 5. Faulty coil L1, L2, or L3. 6. Faulty transformer T1 or T2. 7. NOTE: Refer to Point-To-Point Test.
Radio "motorboats" (pulsating sound output).	<ol style="list-style-type: none"> 1. Open capacitor C22 or C23. 2. Weak batteries.
Sound distorted.	<ol style="list-style-type: none"> 1. Batteries weak. 2. Improper alignment. 3. Volume turned up too high. 4. Faulty diode D2. 5. Electrolytic capacitor installed wrong. 6. Faulty transistor Q5 or Q6.

POINT-TO-POINT TEST

This test is an easy way to locate a faulty transistor or stage in your Radio. Use this test when the Radio is completely dead, or when there is a hiss in the speaker but no stations are received. A screwdriver is used to touch the collector (C) and base (B) leads of each transistor. A weak click heard in the speaker indicates that the

transistor and its associated components are functioning.

Figure 1 (fold-out from Page 27) shows transistor and lead locations. Perform the test, using the following chart.

TEST CHART

TRANSISTOR	LEAD	POSSIBLE CAUSE
Q6	C	Check components in this stage.
Q6	B	Transistor Q6.
Q5	C	Check components in this stage.
Q5	B	Transistor Q5.
Q4	C	Check components between stages Q4, Q5, and Q6.
Q4	B	Transistor Q3.
Q3	C	Check components between stages Q3 and Q4.
Q3	B	Transistor Q3.
Q2	C	Check components between stages Q3 and Q2.
Q2	B	Transistor Q2.
Q1	C	Check components between stages Q2 and Q1.
Q1	B	Transistor Q1.

SERVICE INFORMATION

SERVICE

If, after applying the information in this manual and your best efforts, you are still unable to obtain proper performance, it is suggested that you take advantage of the technical facilities which the Heath Company makes available to its customers.

The Technical Consultation Department is maintained for your benefit. This service is available to you at no charge. Its primary purpose is to provide assistance for those who encounter difficulty in the construction, operation or maintenance of HEATHKIT equipment. It is not intended, and is not equipped to function as a general source of technical information involving kit modifications nor anything other than the normal and specified performance of HEATHKIT equipment.

Although the Technical Consultants are familiar with all details of this kit, the effectiveness of their advice will depend entirely upon the amount and the accuracy of the information furnished by you. In a sense, YOU MUST QUALIFY for GOOD technical advice by helping the consultants to help you. Please use this outline:

1. Before writing, fully investigate each of the hints and suggestions listed in this manual under In Case Of Difficulty. Possibly it will not be necessary to write.
2. When writing, clearly describe the nature of the trouble and mention all associated equipment. Specifically report operating procedures, switch positions, connections to other units, and anything else that might help to isolate the cause of trouble.
3. Report fully on the results obtained when testing the unit initially and when following the suggestions under In Case Of Difficulty. Be as specific as possible and include voltage readings if test equipment is available.
4. Identify the kit Model Number and Series Number, and date of purchase, if available. Also mention the date of the kit assembly manual. (Date at bottom of Page 1.)
5. Print or type your name and address, preferably in two places on the letter.

With the preceding information, the consultant will know exactly what kit you have, what you would like it to do for you and the difficulty you wish to correct. The date of purchase tells him whether or not engineering changes have been made since it was shipped to you. He will know what you have done in an effort to locate the cause of trouble and, thereby, avoid repetitious suggestions. In short, he will devote full time to the problem at hand, and through his familiarity with the kit, plus your accurate report, he will be able to give you a complete and helpful answer. If replacement parts are required, they will be shipped to you, subject to the terms of the Warranty.

The Factory Service facilities are also available to you, in case you are not familiar enough with electronics to provide our consultants with sufficient information on which to base a diagnosis of your difficulty, or in the event that you prefer to have the difficulty corrected in this manner. You may return the completed equipment to the Heath Company for inspection and necessary repairs and adjustments. You will be charged a minimal service fee, plus the price of any additional parts or material required. However, if the completed kit is returned within the Warranty period, parts charges will be governed by the terms of the Warranty. State the date of purchase, if possible.

Local Service by Authorized HEATHKIT Service Centers is also available in some areas and often will be your fastest, most efficient method of obtaining service. HEATHKIT Service Centers will honor the regular 90 day HEATHKIT Parts Warranty on all kits, whether purchased through a dealer or directly from the Heath Company; however, it will be necessary that you verify the purchase date of your kit.

Under the conditions specified in the Warranty, replacement parts are supplied without charge; however, if the Service Center assists you in locating a defective part (or parts) in your kit, or installs a replacement part for you, you may be charged for this service.

HEATHKIT equipment purchased locally and returned to Heath Company for service must be accompanied by your copy of the dated sales receipt from your authorized HEATHKIT dealer in order to be eligible for parts replacement under the terms of the Warranty.

THIS SERVICE POLICY APPLIES ONLY TO COMPLETED EQUIPMENT CONSTRUCTED IN ACCORDANCE WITH THE INSTRUCTIONS AS STATED IN THE MANUAL. Equipment that has been modified in design will not be accepted for repair. If there is evidence of acid core solder or paste fluxes, the equipment will be returned NOT repaired.

For information regarding modification of HEATHKIT equipment for special applications, it is suggested that you refer to any one or more of the many publications that are available on all phases of electronics. They can be obtained at or through your local library, as well as at most electronic equipment stores. Although the Heath Company sincerely welcomes all comments and suggestions, it would be impossible to design, test, evaluate and assume responsibility for proposed circuit changes for special purposes. Therefore, such modifications must be made at the discretion of the kit builder, using information available from sources other than the Heath Company.

REPLACEMENTS

Material supplied with HEATHKIT products has been carefully selected to meet design requirements and ordinarily will fulfill its function without difficulty. Occasionally, improper operation can be traced to a faulty component. Should inspection reveal the necessity for replacement, write to the Heath Company and supply all of the following information.

- A. Thoroughly identify the part in question by using the part number and description found in the manual Parts List.
- B. Identify the kit Model Number and Series Number.

- C. Mention date of purchase.
- D. Describe the nature of defect or reason for requesting replacement.

The Heath Company will promptly supply the necessary replacement. PLEASE DO NOT RETURN THE ORIGINAL COMPONENT UNTIL SPECIFICALLY REQUESTED TO DO SO. Do not dismantle the component in question as this will void the guarantee. This replacement policy does not cover the free replacement of parts that may have been broken or damaged through carelessness on the part of the kit builder.

SHIPPING INSTRUCTIONS

In the event that your instrument must be returned for service, these instructions should be carefully followed.

Wrap the equipment in heavy paper, exercising care to prevent damage. Place the wrapped equipment in a stout carton of such size that at least three inches of shredded paper, excelsior, or other resilient packing material can be placed between all sides of the wrapped equipment and the carton. Close and seal the carton with gummed paper tape, or alternately, tie securely with stout cord. Clearly print the address on the carton as follows:

To: HEATH COMPANY
Benton Harbor, Michigan 49023

ATTACH A LETTER TO THE OUTSIDE OF THE CARTON BEARING YOUR NAME, COMPLETE ADDRESS, DATE OF PURCHASE, AND A BRIEF DESCRIPTION OF THE DIFFICULTY ENCOUNTERED. Also, include your name and return address on the outside of the carton. Preferably affix one or more "Fragile" or "Handle With Care" labels to the carton, or otherwise so mark with a crayon of bright color. Ship by insured parcel post or prepaid express; note that a carrier cannot be held responsible for damage in transit if, in HIS OPINION, the article is inadequately packed for shipment.



WARRANTY

Heath Company warrants that all Heathkit parts shall be free of all defects in materials and workmanship under normal use and service, and in fulfillment of such warranty Heath Company will, for a period of three months from the date of shipment, replace any part upon verification that it is defective.

The foregoing warranty shall apply only to the original buyer, and is and shall be in lieu of all other warranties, whether express or implied and of all other obligations or liabilities on the part of Heath Company and in no event shall Heath Company be liable for any anticipated profits, consequential damages, loss of time or other losses incurred by the buyer in connection with the purchase, assembly or operation of Heathkits or components thereof. No replacement shall be made of parts damaged by the buyer in the course of handling or assembling Heathkit equipment.

The foregoing warranty is completely void if corrosive solder or fluxes have been used in wiring the equipment. Heath Company will not replace or repair any equipment in which corrosive solder or fluxes have been used.

This warranty applies only to Heath equipment sold and shipped within the continental United States including APO and FPO shipments. Warranty replacement for Heathkit equipment outside the United States is on an f.o.b. factory basis. Contact the Heathkit authorized distributor in your country or write: Heath Company, International Division, Benton Harbor, Michigan, U.S.A.

HEATH COMPANY

SPECIFICATIONS

Tuning Range.	535 to 1620 kilocycles.
Intermediate Frequency (IF).	455 kilocycles.
Sensitivity.	50 microvolts per meter for 10 db signal-to-noise ratio at 50 milliwatts output.
6 db Bandwidth at 1000 Kilocycles.	5000 cps.
Audio Output.	250 milliwatts at 10% distortion.
Batteries.	Six 1-1/2 volt size D cells.
Speaker.	4" x 6" oval, permanent magnet.
Transistors.	1 - L842 RF amplifier. 1 - E843 RF converter. 1 - E844 IF amplifier. 1 - A845 Driver. 2 - B846 Audio output.
Diodes.	2 - SSD974 (1-detector and 1-voltage and temperature compensating).
Dimensions.	8-7/8" wide x 7" high x 3-3/4" deep.
Net Weight.	4-1/4 lbs, with batteries.

All prices are subject to change without notice. The Heath Company reserves the right to discontinue instruments and to change specifications at

any time without incurring any obligation to incorporate new features in instruments previously sold.

CIRCUIT DESCRIPTION

Trace through the Schematic Diagram when reading this Circuit Description to obtain a better understanding of the circuits.

The 6-transistor circuit of this Radio consists of an RF amplifier, and oscillator-mixer stage, an IF amplifier, a diode detector, a driver amplifier, and a push-pull audio output stage.

RF signals are picked up by rod antenna L1. The desired signal is selected by a tuned circuit consisting of the primary winding of L1 and tuning capacitor C2. This signal is then coupled through the secondary winding of the antenna coil to the base of RF amplifier transistor Q1. Base bias for transistor Q1 is supplied through resistor R1 which is connected to the AVC circuit. Emitter bias is supplied by resistor R2.

From the collector of transistor Q1, the signal is coupled through coil L2 to the base of mixer transistor Q2. The primary winding of coil L2 is tuned to the input signal frequency by capacitor C7. Base bias for transistor Q2 is supplied by resistor R3; emitter bias is supplied through resistor R4.

Oscillator coil L3 is tuned to a frequency 455 kc above the incoming signal by the oscillator section of the tuning capacitor, C11. Feedback capacitor C10 returns the oscillator signal to the emitter of transistor Q2. The input signal at the base and the oscillator signal at the emitter are then mixed in transistor Q2 to produce a 455 kc IF signal.

The 455 kc IF signal is coupled from the collector of transistor Q2 through transformer T1 to the base of IF amplifier transistor Q3. The signal is amplified by transistor Q3 and coupled through transformer T2 to diode D1, where detection occurs. The detected signal is then coupled from diode D1 to Volume control R13.

The detected signal from D1 also develops the AVC voltage when it is applied to the filter circuit consisting of resistor R11 and capacitors C15 and C19. This AVC voltage is applied through resistors R1 and R8 to the base of transistors Q1 and Q3.

From the Volume control, the audio signal is coupled through capacitor C20 to the base of driver amplifier transistor Q4. From Q4, the signal is coupled through driver transformer T3 to push-pull output amplifiers Q5 and Q6. From Q5 and Q6, the signal is coupled through output transformer T4 to the speaker.

Diode D2 operates as a voltage and temperature compensating device to maintain maximum efficiency in output stages Q5 and Q6. Also, as the batteries become weaker and the voltage drops, diode D2 compensates by causing the proper bias voltage to be applied to the bases of transistors Q5 and Q6.

Resistor R15 and capacitors C22 and C23 provide isolation between circuits in the audio stages. Similarly, resistor R7 and capacitor C14 provide isolation between the IF and converter stages.

Power for the Radio is supplied by six 1-1/2 volt batteries. The Off-On switch is connected in series with the positive terminal of the batteries and the Radio circuitry.

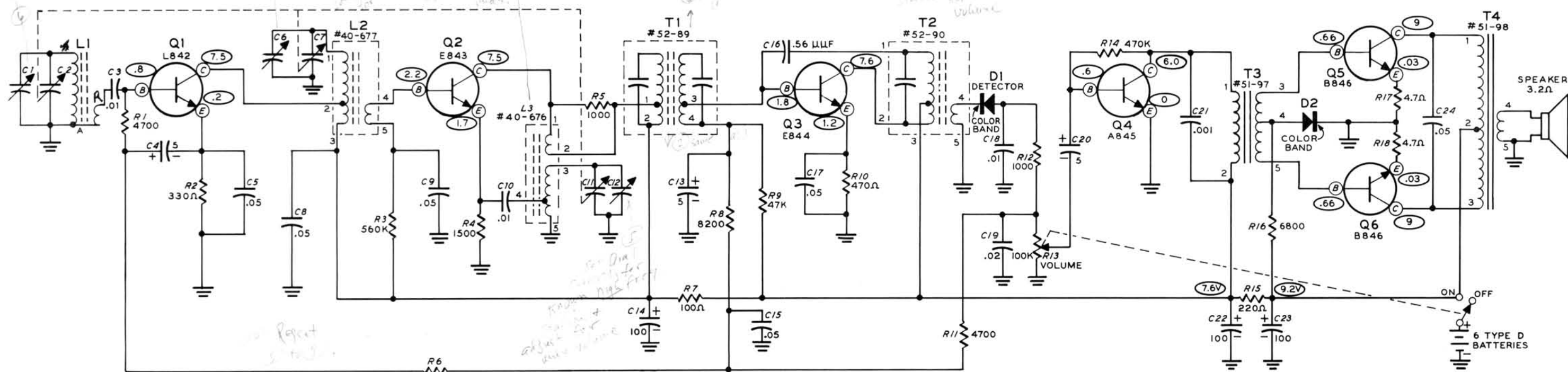

SCHMATIC OF THE HEATHKIT AM PORTABLE RADIO MODEL GR-24

NOTES:
ALL CAPACITOR VALUES IN μ FD UNLESS SPECIFIED OTHERWISE.
ALL RESISTOR VALUES IN OHMS; K=1000.
ALL RESISTORS ARE 1/2 WATT.
○ INDICATES VOLTAGE READINGS.
VOLTAGES TAKEN WITH AN 11 MEGOHM INPUT VTVM.
VOLTAGE READINGS ARE DC FROM POINT INDICATED TO CHASSIS GROUND WITH NO SIGNAL.

Handwritten notes:
① - L1
② - T1
③ - C12
④ - C11
⑤ - C6
⑥ - L3
⑦ - L2
Repeat 5-7

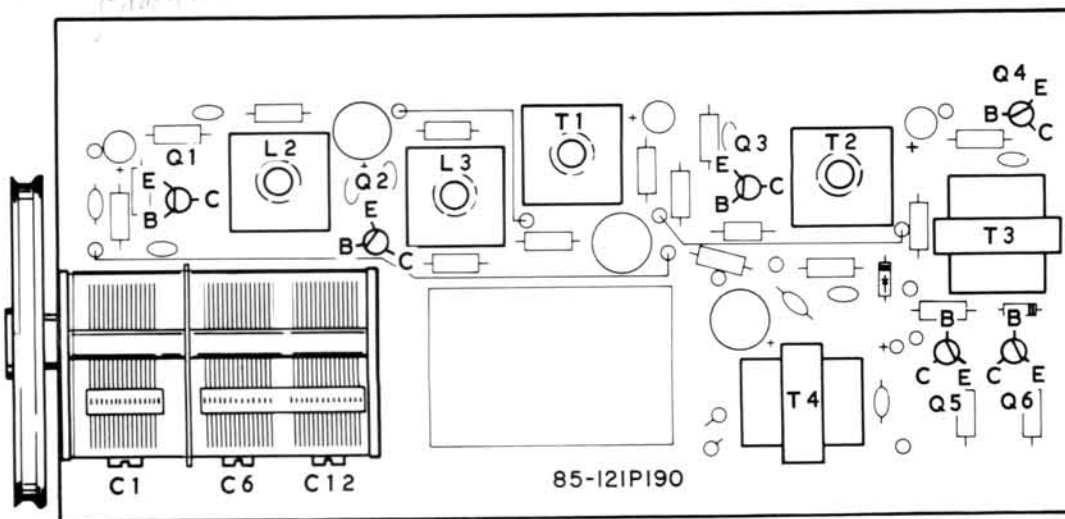
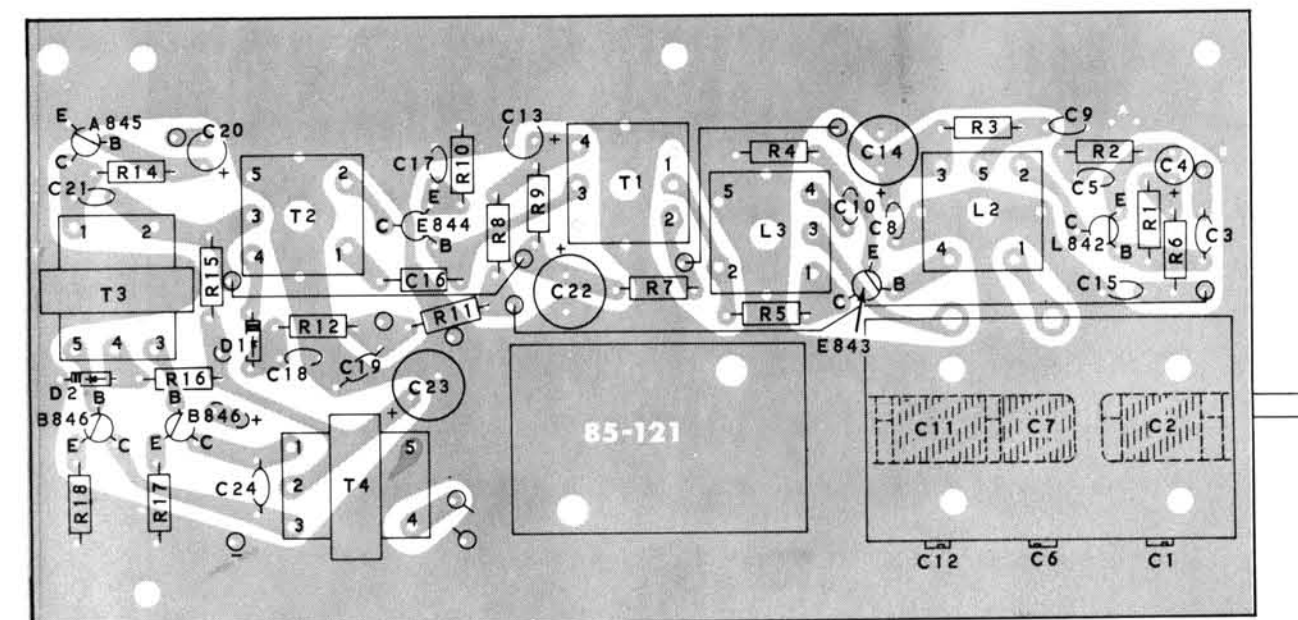

FIGURE 1











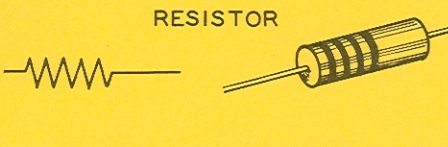
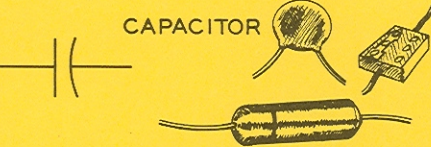
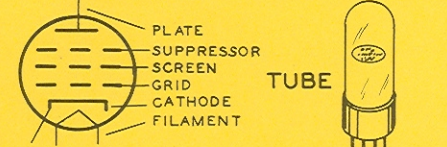
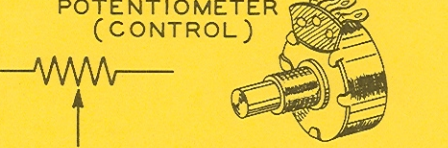





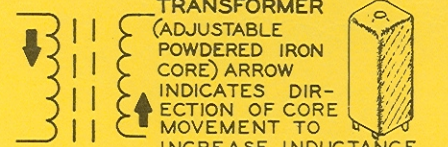
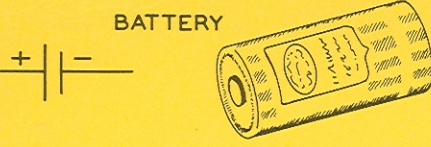

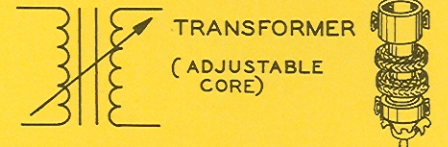

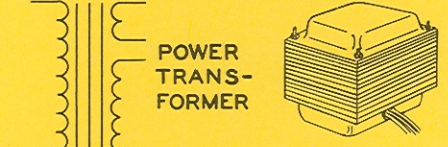



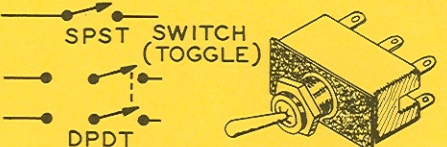



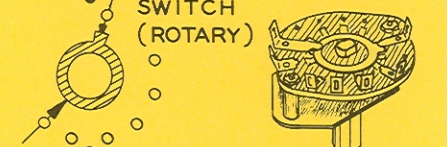

CIRCUIT BOARD X-RAY VIEW (VIEWED FROM FOIL SIDE)

TYPICAL COMPONENT TYPES

This chart is a guide to commonly used types of electronic components. The symbols and related illustrations

should prove helpful in identifying most parts and reading the schematic diagrams.

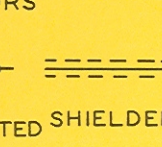
<p style="text-align: center;">RESISTOR</p> 	<p style="text-align: center;">CAPACITOR</p> 	<p style="text-align: center;">TUBE</p> 
<p style="text-align: center;">POTENTIOMETER (CONTROL)</p> 	<p style="text-align: center;">ELECTROLYTIC CAPACITOR</p> 	<p style="text-align: center;">PNP TRANSISTOR</p>  <p style="text-align: center;">NPN TRANSISTOR</p> 
<p style="text-align: center;">TRANSFORMER (IRON CORE)</p> 	<p style="text-align: center;">VARIABLE CAPACITOR</p> 	<p style="text-align: center;">RECTIFIER (DIODE)</p> 
<p style="text-align: center;">TRANSFORMER (ADJUSTABLE POWDERED IRON CORE) ARROW INDICATES DIR- ECTION OF CORE MOVEMENT TO INCREASE INDUCTANCE</p> 	<p style="text-align: center;">BATTERY</p> 	<p style="text-align: center;">NEON BULB</p> 
<p style="text-align: center;">TRANSFORMER (ADJUSTABLE CORE)</p> 	<p style="text-align: center;">PHONO JACK</p> 	<p style="text-align: center;">ILLUMINATING BULB</p> 
<p style="text-align: center;">POWER TRANS- FORMER</p> 	<p style="text-align: center;">PHONE JACK</p> 	<p style="text-align: center;">METER</p> 
<p style="text-align: center;">INDUCTOR (COIL)</p> 	<p style="text-align: center;">RECEPTACLE</p> 	<p style="text-align: center;">SPST SWITCH (TOGGLE)</p>  <p style="text-align: center;">DPDT</p> 
<p style="text-align: center;">PIEZOELECTRIC CRYSTAL</p> 	<p style="text-align: center;">SPEAKER</p> 	<p style="text-align: center;">SWITCH (ROTARY)</p> 
<p style="text-align: center;">BINDING POST</p> 	<p style="text-align: center;">MICROPHONE</p> 	<p style="text-align: center;">FUSE</p> 
<p style="text-align: center;">ANTENNA</p> <p style="text-align: center;">GENERAL</p>  <p style="text-align: center;">LOOP</p> 	<p style="text-align: center;">EARTH GROUND</p>  <p style="text-align: center;">CHASSIS GROUND</p> 	<p style="text-align: center;">CONDUCTORS</p> <p style="text-align: center;">NOT CONNECTED</p>  <p style="text-align: center;">CONNECTED</p>  <p style="text-align: center;">SHIELDED</p> 

HEATH COMPANY

BENTON HARBOR, MICHIGAN

THE WORLD'S FINEST ELECTRONIC EQUIPMENT IN KIT FORM